

# urban ambiance

## UQL1094

### EXTERIOR PENDANT LIGHT

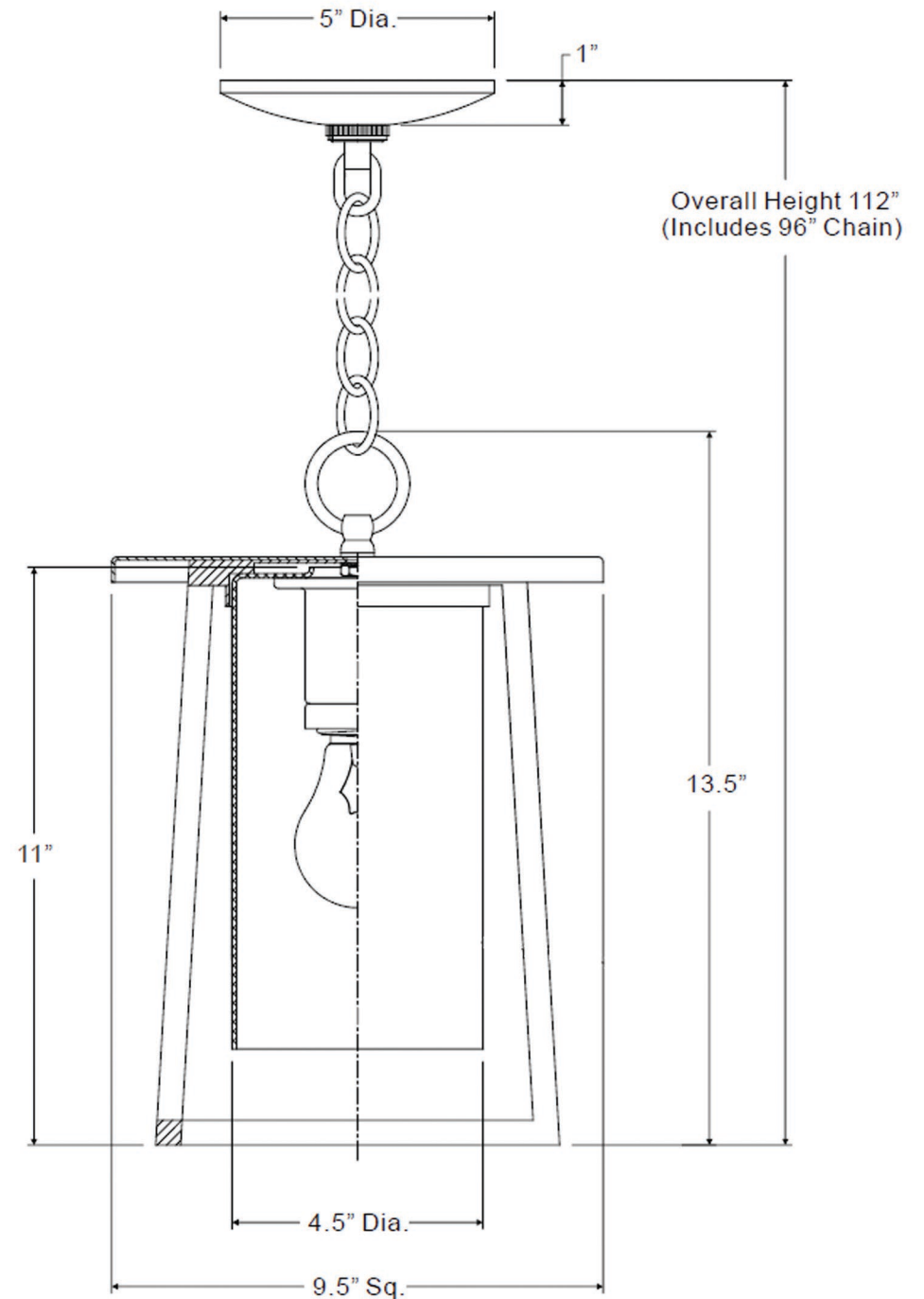

<b>Collection</b>	Lisbon
<b>Finish</b>	Black Silk
<b>Shade</b>	Clear Hammered Glass
<b>Bulb Type</b>	A19 Medium Base
<b>Bulb Wattage</b>	100
<b>Number of Bulbs</b>	1
<b>Bulbs Included</b>	No
<b>Certification</b>	ETL Listed
<b>Rated For</b>	Damp
<b>Weight</b>	7 Pounds
<b>Chain Length</b>	8 Feet
<b>Extension Rods</b>	N/A
<b>Material Construction</b>	Aluminum