

urban ambiance

Ceiling Fan Installation Manual

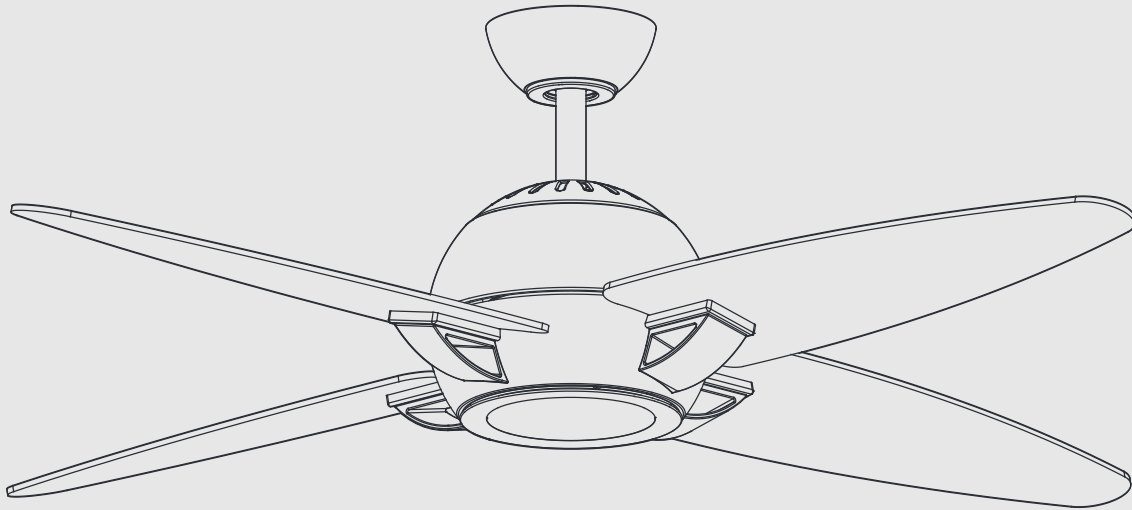

UHP9190
UHP9191
UHP9192

Safety Rules	1
Unpacking Your Fan	2
Installing Your Fan	3
Making the Electrical Connections	6
Operating Your Fan	9
Care of Your Fan	10
Troubleshooting	10
Specifications	11

Table of Contents

READ AND SAVE THESE INSTRUCTIONS

1. To reduce the risk of electric shock, insure electricity has been turned off at the circuit breaker or fuse box before beginning.
2. All wiring must be in accordance with the National Electrical Code ANSI/NFPA 70-1999 and local electrical codes. Electrical installation should be performed by a qualified licensed electrician.
3. **CAUTION:** To reduce the risk of personal injury, use only the screws provided with the electrical box.
4. The outlet box and support structure must be securely mounted and capable of reliably supporting 35 lbs. (15.9 kg). Use only UL Listed outlet boxes marked “Acceptable for Fan Support of 35 lbs. (15.9 kg) or less.”
5. **CAUTION:** The fan must be mounted with a **minimum of 7 feet clearance** from the trailing edge of the blades to the floor.
6. Do not operate reversing switch while fan blades are in motion. Fan must be turned off and blades stopped before reversing blade direction.
7. Avoid placing objects in path of the blades.
8. To avoid personal injury or damage to the fan and other items, be cautious when working around or cleaning the fan.
9. Do not use water or detergents when cleaning the fan or fan blades. A dry dust cloth or lightly dampened cloth will be suitable for most cleaning.
10. After making electrical connections, spliced conductors should be turned upward and pushed carefully up into electrical box. The wires should be spread apart with the grounded conductor and the equipment-grounding conductor on one side of the electrical box and ungrounded conductor on the other side of the electrical box.
11. Electrical diagrams are for reference only. Light kits that are not packed with the fan must be UL Listed and marked suitable for use with the model fan you are installing. Switches must be UL General Use Switches. Refer to the instructions packaged with the light kits and switches for proper assembly.

WARNING

TO REDUCE THE RISK OF FIRE, ELECTRIC SHOCK OR PERSONAL INJURY, MOUNT TO OUTLET BOX MARKED “ACCEPTABLE FOR FAN SUPPORT OF 35LBS. (15.9 KG) OR LESS”, AND USE SCREWS PROVIDED WITH THE OUTLET BOX.

WARNING

TO REDUCE THE RISK OF PERSONAL INJURY, DO NOT BEND THE BLADE BRACKETS (ALSO REFERRED TO AS (“FLANGES”)) DURING ASSEMBLY OR AFTER INSTALLATION. DO NOT INSERT OBJECTS IN THE PATH OF THE BLADES.

12. All set screws must be checked and retightened where necessary before installation.
13. **WARNING:** To reduce the risk of fire or electric shock, this fan should only be used with fan speed control part no. UC7067RY, manufactured by Rhine Electronic Co., Ltd.
14. Suitable for use with solid-state speed controls.

WARNING

TO REDUCE THE RISK OF SHOCK, THIS FAN MUST BE INSTALLED WITH AN ISOLATION CONTROL/SWITCH.

1. Safety Rules

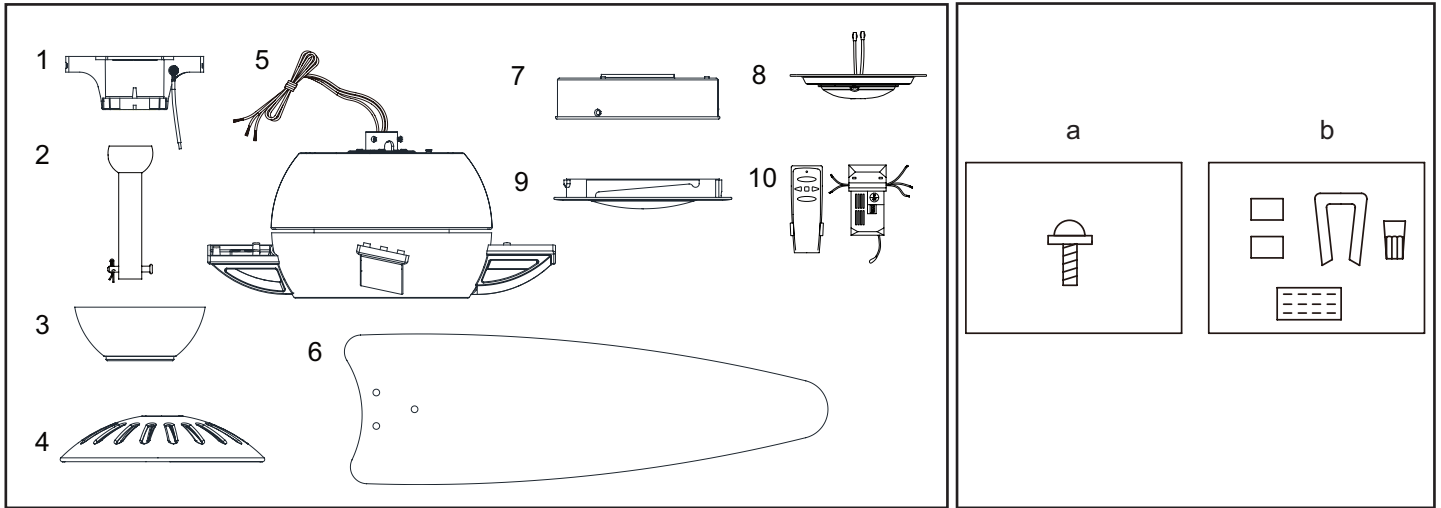

Unpack your fan and check the contents. You should have the following items:

- | | | |
|--|--|---|
| <ol style="list-style-type: none"> 1. Mounting Bracket (inside canopy) 2. 6" Ball/Downrod Assembly (hanger pin and locking pin pre-attached) 3. Canopy with Bottom Cover (attached) 4. Decorative Motor Collar Cover | <ol style="list-style-type: none"> 5. Fan Motor Assembly 6. Blades (4) 7. Light Kit Pan 8. Light Kit Fitter Assembly 9. Shatter-resistant Shade 10. Transmitter and Receiver | <ol style="list-style-type: none"> a. Blade attachment hardware
(13 Screws) b. Electrical hardware and Balancing kit
(3 plastic wire connectors, blade balancing kit) |
|--|--|---|

2. Unpacking Your Fan

Tools Required

Phillips screw driver or straight slotted screw driver, adjustable wrench, step ladder, and wire cutters.



Mounting Options

If there isn't an existing electrical box, then read the following instructions. **Disconnect the power by removing fuses or turning off circuit breakers.**

Secure the electrical box directly to the building structure. Use appropriate fasteners and building materials. The electrical box and its support must be able to fully support the moving weight of the fan (at least 35 lbs.). **Do not use plastic electrical boxes.**

WARNING

TO REDUCE THE RISK OF FIRE, ELECTRIC SHOCK OR PERSONAL INJURY, MOUNT TO OUTLET BOX MARKED "ACCEPTABLE FOR FAN SUPPORT OF 35LBS. (15.9 KG) OR LESS", AND USE SCREWS PROVIDED WITH THE OUTLET BOX. ELECTRICAL BOXES COMMONLY USED FOR THE SUPPORT OF LIGHTING FIXTURES MAY NOT BE ACCEPTABLE FOR FAN SUPPORT AND MAY NEED TO BE REPLACED. CONSULT A QUALIFIED ELECTRICIAN IF IN DOUBT.

Figures 1, 2, and 3 are examples of different ways to mount the electrical box.

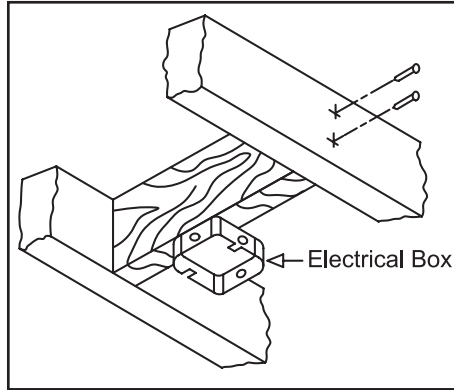

Figure 1

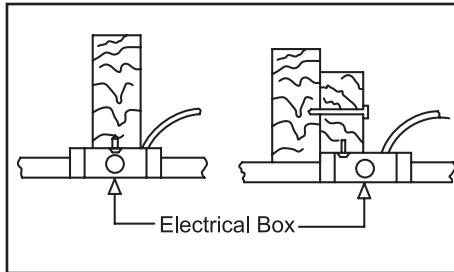

Figure 2

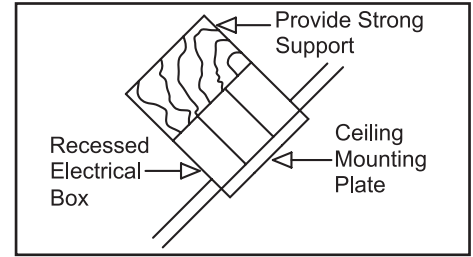

Figure 3

Note: You may need a longer downrod to maintain proper blade clearance when installing on a steep, sloped ceiling. The maximum angle allowable is 20°.

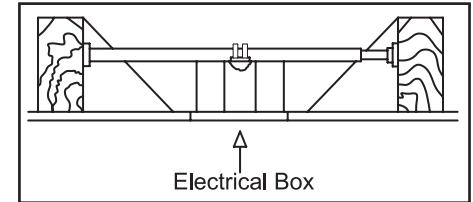

Figure 4

To hang your fan where there is an existing fixture but no ceiling joist, you may need an installation hanger bar as shown in Figure 4.

3. Installing Your Fan

Hanging the Fan

REMEMBER to turn off the power. Follow the steps below to hang your fan properly.

NOTE: This fan is recommended for standard ceiling mount using the downrod provided with this fan. When using standard ceiling installation with the 6 inch downrod provided, the distance from the ceiling to the bottom of the fan blades will be approximately 13 inches.

Standard Ceiling Mounting

1. Remove the canopy bottom cover from the canopy by turning the canopy bottom cover counter-clockwise until it unlocks. (Figure 5)
2. Remove the non-slotted screw and loosen but do not remove the slotted screw. This will enable you to remove the mounting bracket from the canopy. (Figure 6)
3. Remove the hanger pin and locking pin from downrod assembly.
4. Route the wires exiting the top of the fan motor through the decorative motor collar cover then the center of the canopy bottom cover. Make sure the slot opening are on top. Route the wires through the canopy and then through the ball/downrod assembly. (Figure 7)

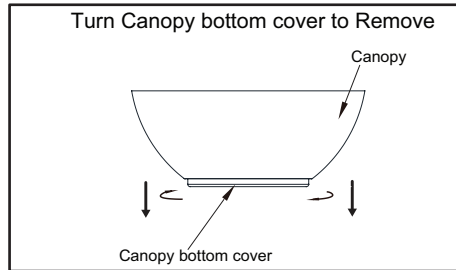

Figure 5

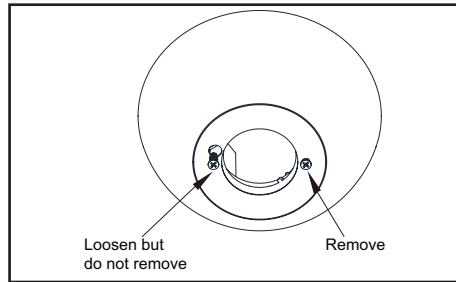

Figure 6

5. Loosen, but do not remove, the set screws on the collar on the top of the motor housing.
6. Align the holes at the bottom of the downrod with the holes in the collar on top of the motor housing. (Figure 7) Carefully insert the hanger pin against the wiring inside the downrod. Insert the locking pin through the hole near the end of the bolt until it snaps into its locked position, as noted in the circle inset of Figure 7.

7. Re-tighten the set screws on the collar on top of the motor housing.
8. Make sure the grommet is properly installed in the collar cover, then slide the collar cover on the downrod until it rests on the motor housing. Be sure that the canopy and the collar cover are both oriented correctly.
9. Proceed to "Installing the Fan" section.

WARNING

FAILURE TO PROPERLY INSTALL SET SCREWS AS NOTED IN STEP 7 COULD RESULT IN FAN LOOSENING AND POSSIBLY FALLING.

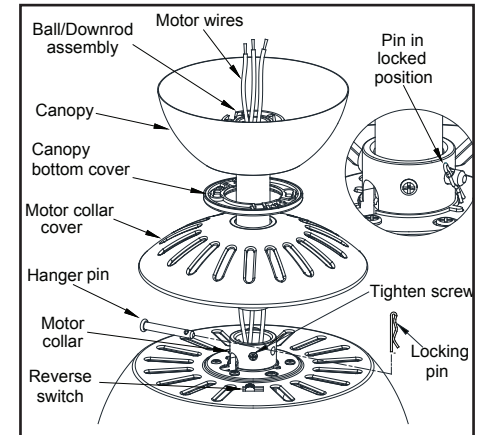

Figure 7

Installing Fan to the Electrical Box

CAUTION

WHEN MOUNTING THE FAN ON A SLOPED CEILING, THE STANDARD BALL/DOWNROD MOUNTING METHOD MUST BE USED. THE MOUNTING PLATE MUST BE MOUNTED SO THAT THE SLOT OPENINGS ARE ON THE LOWER SIDE BY SLIDING THE MOUNTING PLATE FROM THE TOP DOWN.

1. Pass the 120-volt supply wires through the center hole in the ceiling mounting plate as shown in Figure 8.
2. Install the ceiling mounting bracket on the electrical box by using the mounting screws provided with the electrical box. Note that the flat side of the mounting plate is toward the electrical box. (Figure 8)
3. Tighten the two screws on the electrical box securely.
4. Carefully lift the fan assembly up to the ceiling mounting plate. Make sure the tab on the mounting plate is properly seated in the groove in the hanger ball. (Figure 9)

WARNING

WHEN USING THE STANDARD BALL/DOWNROD MOUNTING, THE TAB IN THE RING AT THE BOTTOM OF THE MOUNTING BRACKET MUST REST IN THE GROOVE OF THE HANGER BALL. FAILURE TO PROPERLY SEAT THE TAB IN THE GROOVE COULD CAUSE DAMAGE TO WIRING.

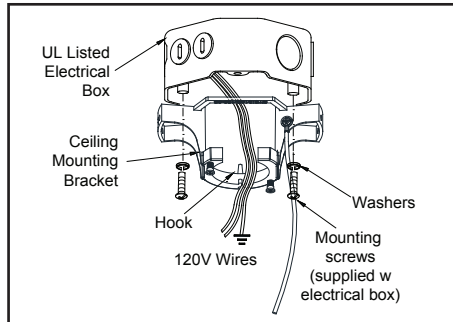

Figure 8

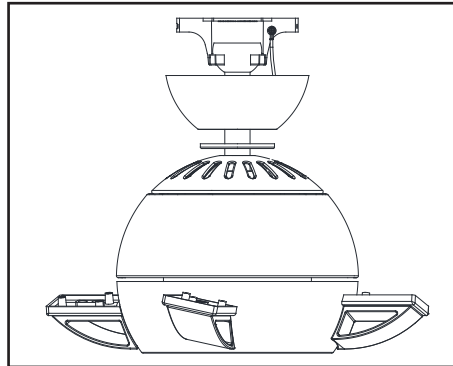

Figure 9

Making the Electrical Connections

REMEMBER to disconnect the power. If you feel you do not have enough electrical wiring knowledge or experience, have your fan installed by a licensed electrician.

Follow the steps below to connect the fan to your household wiring. Use the wire connecting nuts supplied with your fan and supplied with remote control. Secure the connectors with electrical tape. Make sure there are no loose strands or connections. (Figure 10)

1. Connect the ground conductor of the 120v supply (this may be a bare wire or a wire with green colored insulation) to the green ground lead(s) of the fan (Figure 10).
2. Connect the fan motor white wire to the receiver white wire using a wire nut (Figure 10).
3. Connect the fan motor black wire to the receiver black wire using a wire nut (Figure 10).
4. Connect the fan motor blue wire to the receiver blue wire using a wire nut (Figure 10).

5. Connect the receiver black wire to the supply black (hot) wire using a wire nut (Figure 10).
6. Connect the receiver white wire to the supply white (neutral) wire using a wire nut (Figure 10).
7. After connecting the wires, spread them apart so that the green and white wires are one side of the electrical box and the black wire is on the other side.
8. Turn the wire connecting nuts upward and carefully push the wiring into the electrical box.

NOTE

USE THE PLASTIC WIRE CONNECTORS SUPPLIED WITH YOUR FAN. SECURE THE CONNECTORS WITH ELECTRICAL TAPE AND ENSURE THERE ARE NO LOOSE STRANDS OR CONNECTIONS.

WARNING

EACH WIRE NUT (WIRE CONNECTOR) SUPPLIED WITH THIS FAN IS DESIGNED TO ACCEPT UP TO ONE 12 GAUGE HOUSE WIRE AND TWO WIRES FROM THIS FAN. IF YOU HAVE LARGER THAN 12 GAUGE HOUSE WIRING OR MORE THAN ONE HOUSE WIRE TO CONNECT TO THE FAN WIRING, CONSULT AN ELECTRICIAN FOR THE PROPER SIZE WIRE NUTS TO USE.

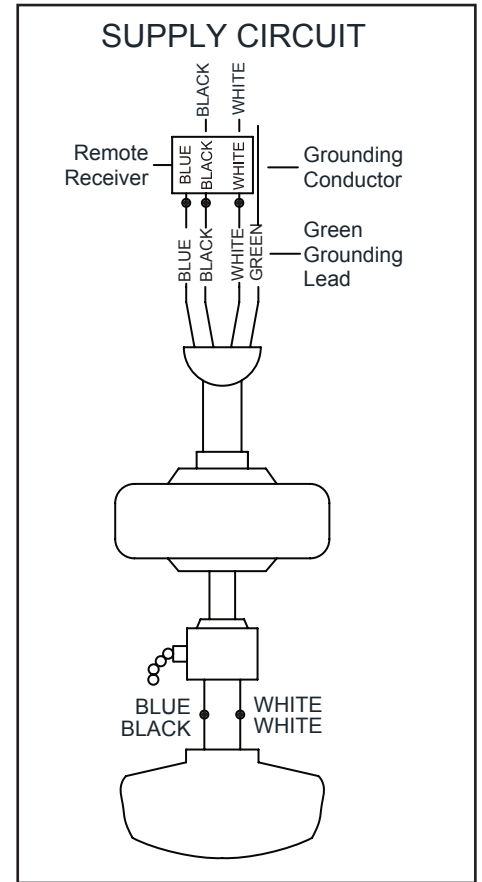

Figure 10

Finishing the Fan Installation

STANDARD CEILING MOUNTING

WARNING

WHEN USING THE STANDARD BALL/DOWNRD MOUNTING, THE TAB IN THE RING AT THE BOTTOM OF THE MOUNTING PLATE MUST REST IN THE GROOVE OF THE HANGER BALL. FAILURE TO PROPERLY SEAT THE TAB IN THE GROOVE COULD CAUSE DAMAGE TO WIRING.

1. Align the locking slots of the ceiling canopy with the screw in the mounting bracket. Push up to engage the slots and turn clockwise to lock in place. Immediately tighten the mounting screw firmly.
2. Install the remaining mounting screw into the canopy and tighten firmly.
3. Install the canopy bottom cover by aligning the slots in canopy bottom cover with the screws in the canopy. Rotate the canopy bottom cover clockwise to lock in place.
4. You may now proceed to attaching the fan blades.

Attaching the Fan Blades

1. Align the three screw holes in the blade with the screw holes in the blade arm and secure with the screws provided. (Figure 11)
2. Repeat for the remaining blades.

Blade Balancing

All blades are grouped by weight. Because natural woods vary in density, the fan may wobble even though the blades are weight matched.

The following procedure should correct most fan wobble. Check after each step.

1. Check that all blade screws are secure.
2. Most fan wobble problems are caused when blade levels are unequal. Check this level by selecting a point on the ceiling above the tip of one of the blades. Measure from a point on the center of each blade to the point on the ceiling. Measure this distance as shown in Figure 12. Rotate the fan until the next blade is positioned for measurement. Repeat for each blade. Measurements deviation should be within 1/8". Run the fan for 10 minutes.

3. Make sure that canopy is tightened securely to ceiling mounting bracket and that the ceiling mounting bracket is tightened securely to the electrical box.
4. Interchanging two adjacent blades can redistribute the weight and possibly result in the smoother operation.
5. Use the enclosed Blade Balancing Kit if the blade wobble is still noticeable.

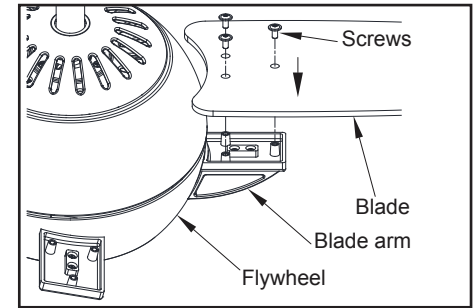

Figure 11

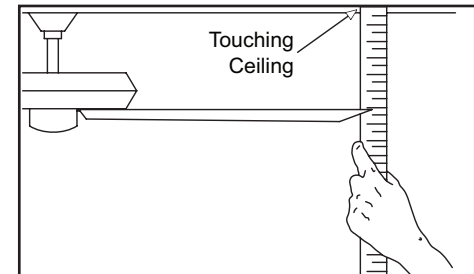

Figure 12

Installing the Light Kit Pan/Light Kit Fitter Assembly/ Shatter-Resistant Bowl

CAUTION - To reduce the risk of electrical shock, disconnect the electrical supply circuit to the fan before installing the light kit.

1. Loosen but do not remove two of three mounting screws from the fan motor assembly; Remove one mounting screw. (Figure 13)
2. Push the light kit pan up to the fan motor assembly so that the two loosened screw heads fit into the keyhole slots. Turn the light kit pan clockwise, tighten the screws. Re-install the screw that was removed in step 1 and tighten firmly. (Figure 13)
3. Remove one screw from the light kit pan and loosen, but do not remove the other two screws. Connect the wires from the light kit fitter assembly to the wires from the fan motor assembly by connecting the molded adaptor plugs together. Carefully tuck all wires and splices into the switch cap. (Figure 14)

4. Push the light kit fitter assembly up so that the two loosened screw heads fit into the keyhole slots. Turn the light kit fitter assembly clockwise, tighten the screws. Re-install the screw that was removed in step 3 and tighten firmly. (Figure 14)
5. Place the shatter-resistant bowl into the light kit pan, aligning the three flat areas on the top of the shatter-resistant bowl with the three raised dimples in the light kit pan. Turn the shatter-resistant bowl clockwise until it stops. (Figure 15)

NOTE

PERIODICALLY CHECK THE SHATTER-RESISTANT BOWL IS SEATED FULLY CLOCKWISE IN THE LIGHT KIT PAN

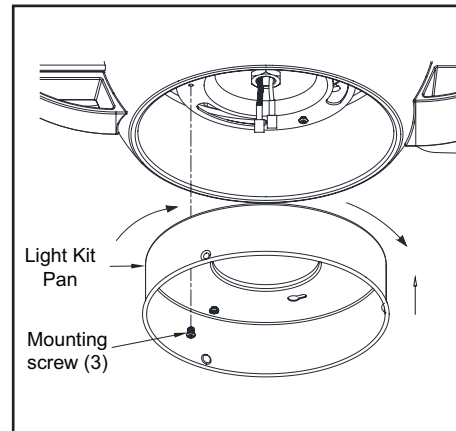

Figure 13

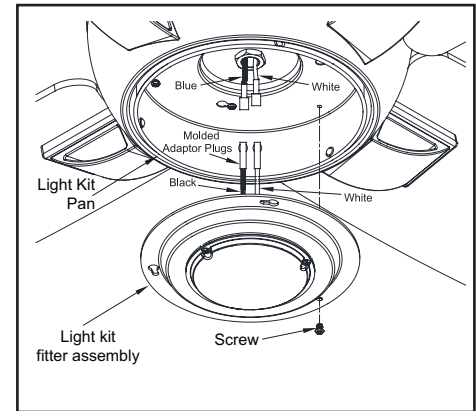

Figure 14

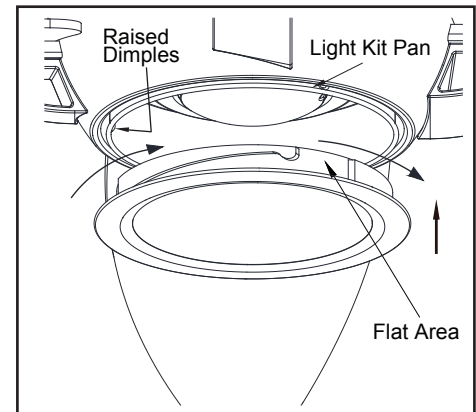

Figure 15

Speed settings for warm or cool weather depend on factors such as room size, ceiling height, number of fans, and so on.

The fan shipped from the factory with the reversing switch positioned to circulate air downward. If airflow is desired in the opposite direction, turn your fan off and wait for the blades to stop turning, then slide the reversing switch (located at the top of the motor housing, refer to figure 7 on page 4) to opposite position, and turn fan on again. The fan blades will turn in the opposite direction and reverse airflow.

Warm weather - (Forward) A downward air flow creates a cooling effect as shown in Figure 16. This allows you to set your air conditioner on a higher setting without affecting your comfort.

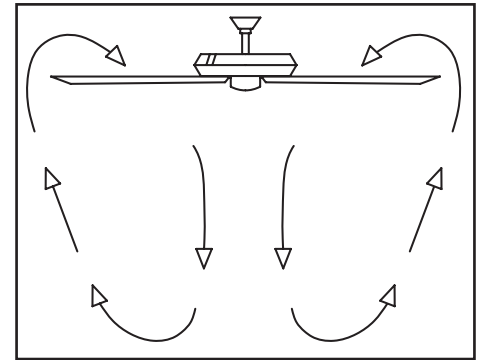

Figure 16

Cool weather - (Reverse) An upward air flow moves warm air off the ceiling as shown in Figure 17. This allows you to set your heating unit on a lower setting without affecting your comfort.

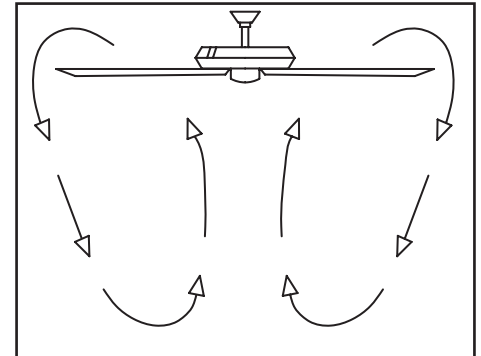

Figure 17

9. Operating Your Fan

Care of Your Fan

Here are some suggestions to help you maintain your fan.

1. Because of the fan's natural movement, some connections may become loose. **Check the support connections, brackets, and blade attachments twice a year.** Make sure they are secure. **(It is not necessary to remove fan from ceiling.)**
2. Clean your fan periodically to help maintain its new appearance over the years. Do not use water when cleaning, this could damage the motor, or the wood or possibly cause an electrical shock. Use only a soft brush or lint-free cloth to avoid scratching the finish. The plating is sealed with a lacquer to minimize discoloration or tarnishing. **Warning - Make sure the power is off before cleaning your fan.**
3. You can apply a light coat of furniture polish to the wood for additional protection and enhanced beauty. Cover small scratches with a light application of shoe polish.
4. **There is no need to oil your fan.** The motor has permanently lubricated sealed ball bearings.

Troubleshooting

Problem

Solution

Fan will not start

1. Check main and branch circuit fuses or breakers
2. Check line wire connections to the fan and switch wire connections in the switch housing. **CAUTION: Make sure main power is off.**
3. Check batteries in the transmitter. Does the red LED light come on? Are you standing close enough to the fan? (Normal range is 10-20 feet.) Are the dip switch settings the same on the transmitter (hand unit) and receiver? **REMEMBER TO TURN OFF POWER SUPPLY BEFORE CHECKING THE DIP SWITCH SETTINGS IN RECEIVER.**

Fan sounds noisy

1. Make sure all motor housing screws are snug.
2. Make sure the screws that attach the fan blade bracket to the motor hub are tight.
3. Make sure wire nut connections are not rattling against each other or the interior wall of the switch housing. **CAUTION: Make sure power is off.**
4. Allow a 24-hour "breaking in" period. Most noises associated with a new fan disappear during this time.
5. If using the Ceiling Fan light kit, make sure the screws securing the glassware are tight. Check that the light bulb is also secure.
6. Make sure the canopy is a short distance from the ceiling. It should not touch the ceiling.
7. Make sure your electrical box is secure and rubber isolator pads were used between the mounting bracket and electrical box.

WARNING

MAKE SURE THE POWER IS OFF AT THE ELECTRICAL PANEL BOX BEFORE YOU ATTEMPT TO MAKE ANY REPAIRS. REFER TO THE SECTION, "MAKING ELECTRICAL CONNECTIONS."

10. Care of Your Fan and Troubleshooting

FAN SIZE	SPEED	VOLTS	FAN POWER CONSUMPTION (WITHOUT LIGHTS) WATTS	AIRFLOW CFM	AIRFLOW EFFICIENCY (HIGHER IS BETTER) CFM/WATT	NET WEIGHT	GROSS WEIGHT	CUBE FEET
54"	Low	120	11	1763	160	19.40 Lbs	22.27 Lbs	2.1
	Med		25	2881	115			
	High		65	4814	74			

This equipment has been tested and found to comply with the limits for a Class B digital device, pursuant to Part 15 of the FCC Rules. These limits are designed to provide reasonable protection against harmful interference in a residential installation. This equipment generates, uses and can radiate radio frequency energy and, if not installed and used in accordance with the instructions, may cause harmful interference to radio communications. However, there is no guarantee that interference will not occur in a particular installation. If this equipment does cause harmful interference to radio or television reception, which can be determined by turning the equipment off and on, the user is encouraged to try to correct the interference by one or more of the following measures:

- Reorient or relocate the receiving antenna.
- Increase the separation between the equipment and receiver.
- Connect the equipment into an outlet on a circuit different from that to which the receiver is connected.
- Consult the dealer or an experienced radio/TV technician for help.

CAUTION:

Any changes or modifications not expressly approved by the grantee of this device could void the user's authority to operate the equipment. This device complies with Part 15 of the FCC Rules. Operation is subject to the following two conditions: (1) This device may not cause harmful interference, and (2) this device must accept any interference received, including interference that may cause undesired operation.

11. Specifications