

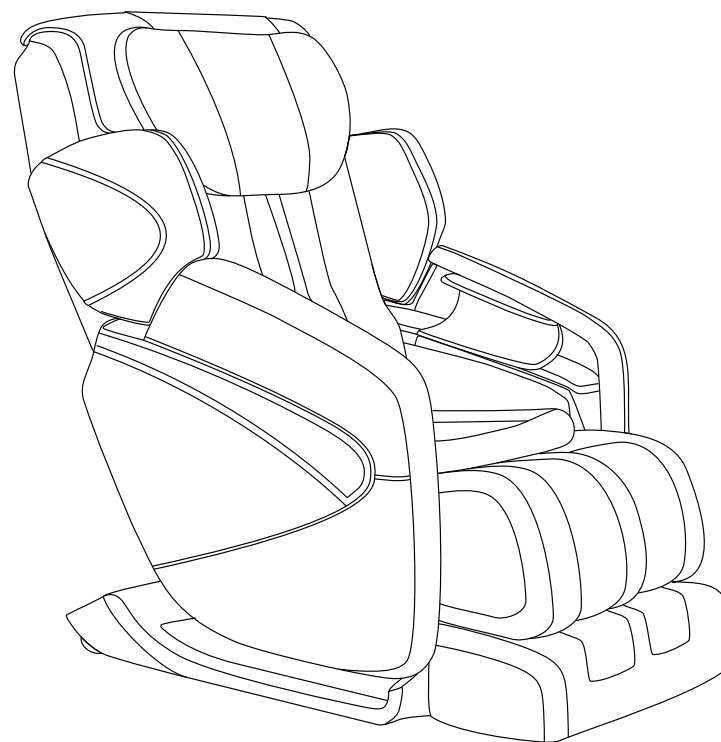

Jin

by inner balance



A Division of Johnson Health Tech, NA.
1600 Landmark Drive, Cottage Grove, WI 53527
877.217.2862 info@ib-wellness.com ib-wellness.com

User Manual

Please read this user manual thoroughly prior to operating the massage chair.
Please keep this manual for future reference.

Contents

Congratulations on purchasing a Jin massage chair. Please read and follow all safety and operating instructions listed in this user manual prior to use. Basic precautions should always be used when operating an electrical appliance.

Safety Instructions.....	3-6
Product Specifications.....	7
Hardware Pack Contents.....	7
Product Components.....	8-9
Chair Installation.....	10-12
Before Use.....	13
Remote Controller.....	14
Operation Guide.....	15-18
Maintenance.....	19
Trouble Shooting.....	20-21



Safety Instructions

SAVE THESE INSTRUCTIONS

GROUNDING INSTRUCTIONS

This product must be grounded. If it should malfunction or breakdown, grounding provides a path of least resistance for electric current to reduce the risk of electric shock. This product is equipped with a cord having an equipment-grounding conductor and a grounding plug. The plug must be plugged into an appropriate outlet that is properly installed and grounded in accordance with all local codes and ordinances.

DANGER – Improper connection of the equipment-grounding conductor can result in a risk of electric shock. Check with a qualified electrician or serviceman if you are in doubt as to whether the product is properly grounded. Do not modify the plug provided with the product - if it will not fit the outlet, have a proper outlet installed by a qualified electrician.

This product is for use on a nominal 120-V circuit, and has a grounding plug that looks like the plug illustrated in sketch A in Figure 86.1. A temporary adapter that looks like the adapter illustrated in sketches B and C may be used to connect this plug to a 2-pole receptacle as shown in sketch B if a properly grounded outlet is not available. The temporary adapter should be used only until a properly grounded outlet (sketch A) can be installed by a qualified electrician. The green colored rigid ear, lug, or the like extending from the adapter must be connected to a permanent ground such as a properly grounded outlet box cover. Whenever the adapter is used, it must be held in place by a metal screw.

Figure 86. 1
Grounding Methods

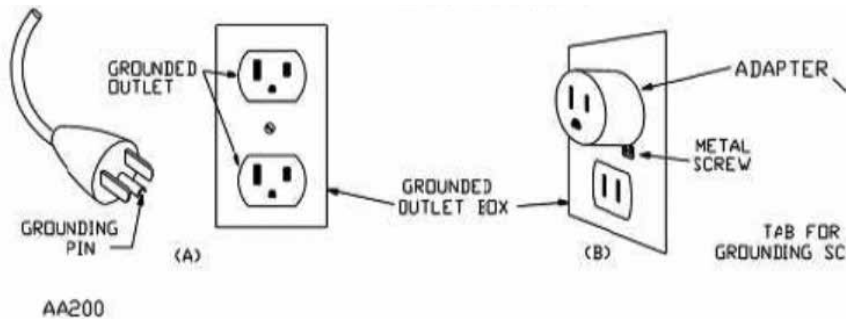

PRECAUCIAONES IMPORTANTES

Safety Instructions

CONSERVEZ CE MODE D' EMPLOI

INSTRUCTIONS VISANT LA MISE À LA TERRE

Cet appareil doit être mis à la terre. En cas de défaillance ou de panne, la mise à la terre fournit au courant un chemin de moindre résistance qui réduit le risque de choc électrique. Cet appareil est pourvu d'un cordon muni d'un conducteur de terre et d'une fiche avec broche de terre. La fiche doit être branchée dans une prise appropriée correctement installée et mise à la terre conformément aux règlements et ordonnances municipaux.

AVERTISSEMENT – Un conducteur de terre mal raccordé peut entraîner un risque de choc électrique. Consulter un électricien ou un technicien d'entretien qualifié si vous n'êtes pas certain que la prise est correctement mise à la terre. Ne pas modifier la fiche fournie avec l'appareil – si elle ne peut être insérée dans la prise, faire installer une prise adéquate par un électricien qualifié.

Cet appareil est destiné à un circuit de 120 V et est muni d'une fiche de mise à la terre semblable à celle illustrée par le croquis A de la figure 20. S'assurer que l'appareil est branché à une prise de courant ayant la même configuration que la fiche. Aucun adaptateur ne devrait être utilisé avec cet appareil.

Figure 86. 1
Grounding Methods

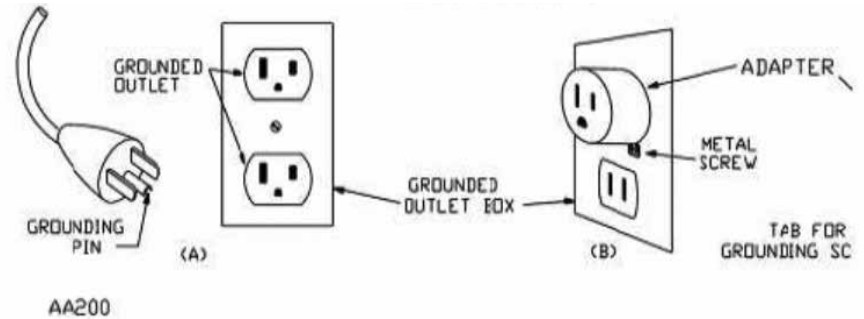

IMPORTANT SAFEGUARDS

When using an electrical appliance, basic precautions should always be followed, including the following:

Read all instructions before using (this appliance).

DANGER – To reduce the risk of electric shock: Always unplug this appliance from the electrical outlet immediately after using and before cleaning.

WARNING – To reduce the risk of burns, fire, electric shock, or injury to persons:

- 1) An appliance should never be left unattended when plugged in. Unplug from outlet when not in use, and before putting on or taking off parts.
 - 2) Do not operate under blanket or pillow. Excessive heating can occur and cause fire, electric shock, or injury to persons.
 - 3) Close supervision is necessary when this appliance is used by, on, or near children, invalids, or disabled persons.
 - 4) Use this appliance only for its intended use as described in this manual. Do not use attachments not recommended by the manufacturer.
 - 5) Never operate this appliance if it has a damaged cord or plug, if it is not working properly, if it has been dropped or damaged, or dropped into water. Return the appliance to a service center for examination and repair.
 - 6) Keep the cord away from heated surfaces.
 - 7) Never operate the appliance with the air openings blocked. Keep the air openings free of lint, hair, and the like.
 - 8) Never drop or insert any object into any opening.
 - 9) Do not use outdoors.
 - 10) Do not operate where aerosol (spray) products are being used or where oxygen is being administered.
 - 11) To disconnect, turn all controls to the off position, then remove plug from outlet.
 - 12) To reduce the risk of electric shock, this appliance has a polarized plug (one blade is wider than the other). This plug will fit in a polarized outlet only one way. If the plug does not fit fully in the outlet, reverse the plug. If it still does not fit, contact a qualified electrician to install the proper outlet. Do not change the plug in any way.
 - 13) Keep children away from extended foot support (or other similar parts).
 - 14) Warning- Connect this appliance to a properly grounded outlet only. See Grounding Instructions.
 - 15) **WARNING** – Do not use massager in close proximity to loose clothing or jewelry. Keep long hair away from massager while in use.
- DANGER** –
- i) Never use pins or other metallic fasteners with this appliance.
 - ii) Carefully examine the covering before each use. Discard the appliance if the covering shows any sign of deteriorations, such as checking, blistering, or cracking.
 - iii) Keep Dry – Do not operate in a wet or moist condition.

SAVE THESE INSTRUCTIONS

IMPORTANT SAUVEGARDES

Lors de l'utilisation d'un appareil électrique, veiller à toujours respecter des précautions élémentaires, notamment ce qui suit:

Lire toutes les instructions avant d'utiliser (cet appareil).

DANGER – Afin de réduire les risques d'électrocution

Débranchez toujours cet appareil de l'alimentation électrique dès que vous avez fini de l'employer et avant de le nettoyer.

MISE EN GARDE – Afin de réduire les risques de brûlure, d'incendie, d'électrocution ou de blessure:

1. Un appareil ne devrait jamais être laissé sans surveillance lorsqu'il est branché. Débranchez l'appareil de l'alimentation lorsque vous ne l'employez pas et avant d'y insérer ou d'en retirer des pièces.
2. Ne pas faire fonctionner sous une couverture ou un oreiller. Un échauffement important peut se produire et provoquer un incendie, une décharge électrique ou des blessures corporelles.
3. Une surveillance étroite est nécessaire lorsque ce fauteuil est employé près ou par des enfants ou des personnes handicapées.
4. Employez ce fauteuil à ce pour quoi il a été conçu, tel que décrit dans ce guide. Employez uniquement les accessoires recommandés par le fabricant.
5. N'employez jamais ce produit si son cordon ou sa fiche d'alimentation sont endommagés, s'il a été immergé. Retournez ce fauteuil à un centre de service pour examen et réparation.
6. Éloignez toujours le cordon d'alimentation de toute source de chaleur.
7. Ne faites jamais fonctionner ce fauteuil si ses trappes d'aération sont obstruées. Maintenez les trappes d'aération exemptes de peluche, de cheveux et de substances semblables.
8. N'échappez ni n'insérez jamais aucun objet dans aucune ouverture.
9. N'employez pas à l'extérieur.
10. Ne faites pas fonctionner dans un endroit où on utilise des produits à bombe aérosol (vaporisateur) ou dans un endroit où de l'oxygène est administrée.
11. Pour débrancher, mettez toutes les commandes à la position OFF (arrêt) et retirez la fiche de la prise.
12. Afin de réduire les risques d'électrocution, cet appareil est doté d'un cordon à fiche polarisée (une lame est plus large que l'autre). Cette fiche ne s'insère que dans un seul sens dans une prise polarisée. Si la fiche ne s'insère pas entièrement dans la prise, inversez la fiche. Si elle ne s'insère toujours pas entièrement, contactez un électricien qualifié pour faire installer une prise appropriée. Ne modifiez pas la fiche d'alimentation électrique.

CONSERVER CES INSTRUCTIONS

Product Specifications

Description	Specifications
Product Name	Massage Chair
Model No.	Jin
Rated Voltage	AC 110V
Rated Frequency	60Hz
Rated Power Consumption	230W
Dimension (LxWxH)	56(L)X30(W)X49(H)in
Weight	Net Weight: 212lb Gross Weight: 251lb

Hardware Pack Contents

- 1 power cord
- 1 M6 Allen wrench
- 6 M6*20 shoulder fixed screws

Product Components

MAIN BODY DIAGRAM (FRONT)

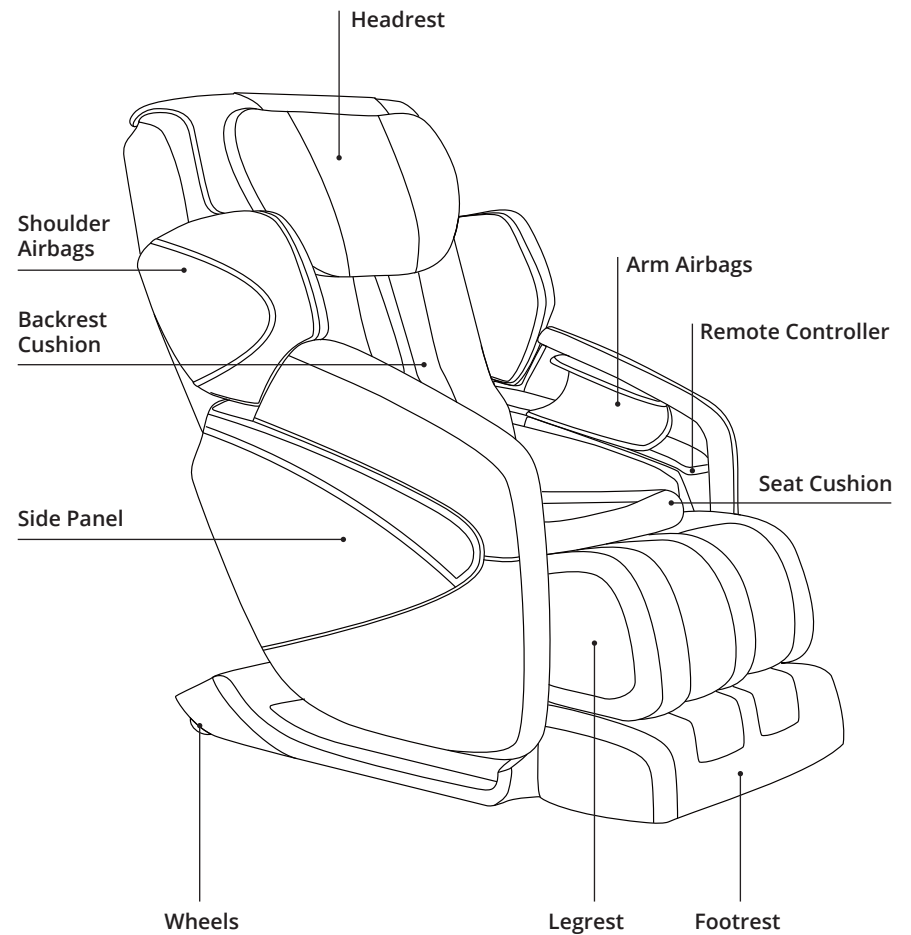

Product Components

MAIN BODY DIAGRAM (REAR)

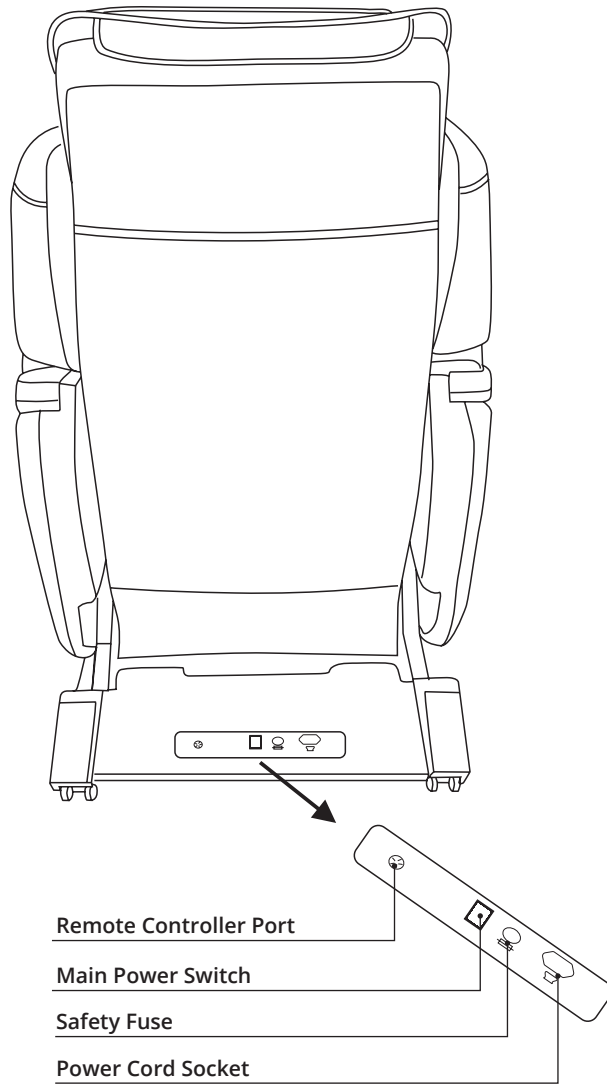

Chair Installation

1. Removing the chair and parts from the package

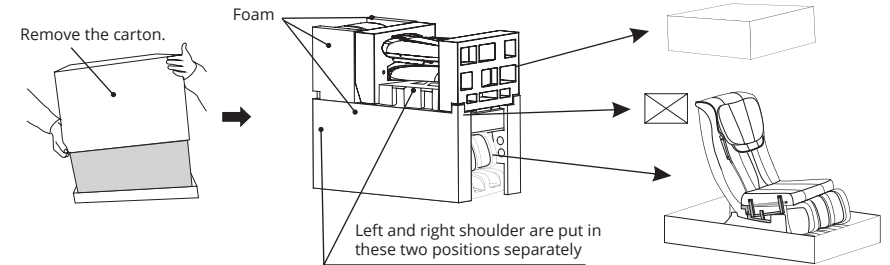

- Lift and remove main outer carton.
- Remove cardboard and foam on both sides of the massage chair.
- Remove accessory box (includes: instructions, power cord etc.).

2. Installing the side panel

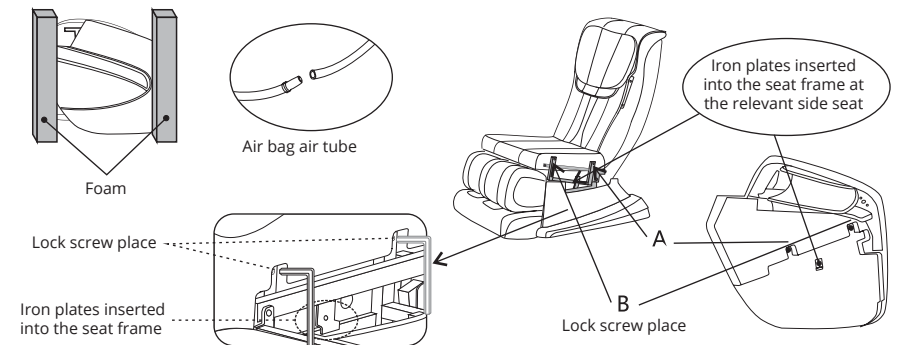

- Remove the side panels from the carton, and take them out to begin assembly.
- Connect the side panel air hose with the air hose coming out of the side of the chair. Both sides of the air hose need to be inserted in order to prevent an air leak and loss of pressure during use.
- Unscrew bolt (B) from the side panel, insert the metal connector plates into the metal pipe which is on the corresponding side of the seat frame (as shown above). At the same time, put the other bolt (A) in the slot on the corresponding seat frame. Then align the holes and screw in bolt (B). Tighten the two screws and repeat this process on both side panels.
- Smooth out the fabric of the chair.

Chair Installation

3. Installing the shoulder airbags

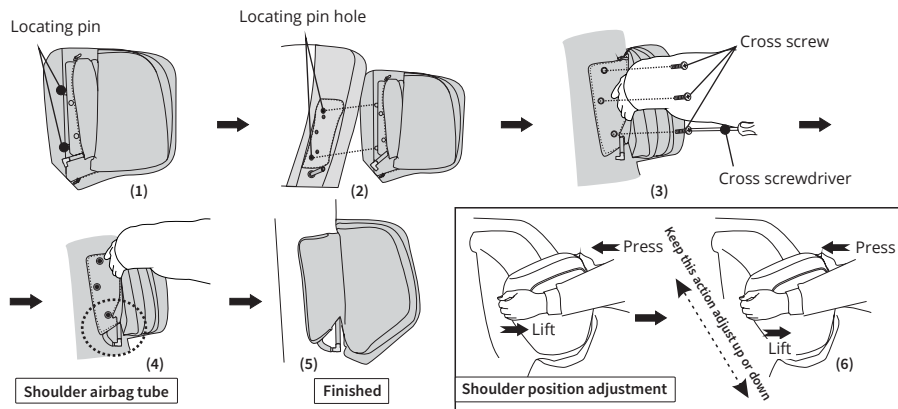

- Unzip the cloth cover for the shoulder airbag components revealing one locating pin and pin hole for each up and down.
- Insert up and down two locating pins into the pin holes on the left side of backrest (as shown). In the screw holes, lock cross screws with the cross screwdriver.
- Insert the air tube joints into air tubes. (Note: They must be inserted completely to prevent air leakage and loss of pressure during use.)
- Zip up the cloth cover.
- Repeat steps a-d on the other side of the chair.
- Adjust the shoulder airbags to fit your shoulder position if needed taking care not to force them into place.

4. Installing the backrest and headrest

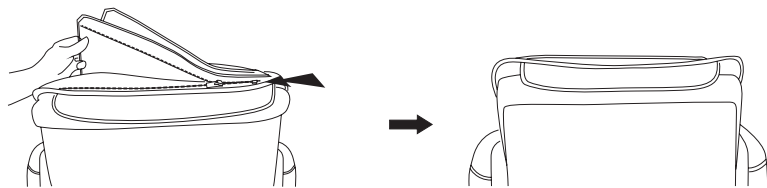

- Use the velcro strips to connect the backrest and cover.
- Smooth out the backrest and seat cushion.

Chair Installation

5. Finding a location for the chair

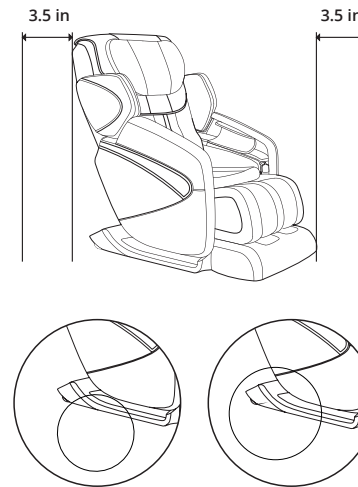

- Place the chair in the desired location and not in direct sunlight.
- Make sure there is at least 3.5 in behind and in front of the chair.

6. Moving the massage chair

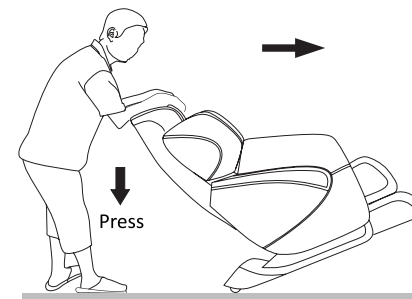

- Press down the back of massage chair to approximately 45° degree angle.
- This will allow it to easily be moved to another location.

CAUTION:

- * Do not move massage chair when occupied or in use.
- * Moving the massage chair may cause damage to floors. Floor protection is recommended.
- * Do not drop or suddenly let go of the chair while moving it.
- * Using two people to move the chair is recommended. The second person should lift up the legrest, while one person holds the backrest

Before Use

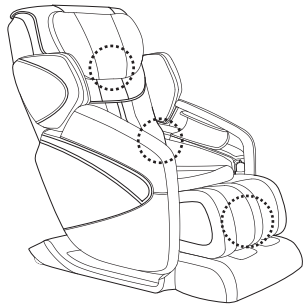

1. Make sure that the product is in good condition.
 - Confirm that the headrest, backrest and power plug are not damaged.
 - Make sure the footrest is in its right position (as shown in the diagram to the left).

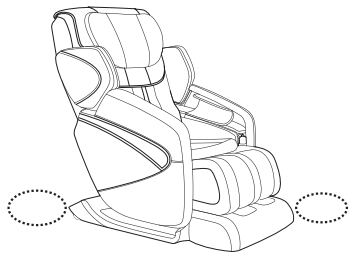

2. Check the surrounding area to make sure it's clear of anything obstructing the chair's incline/recline.
 - Make sure there are at least 3.5 inches in front and back of chair.



3. Connect the chair to a power source.
 - Plug the chair in.
 - Turn the power switch to "on."

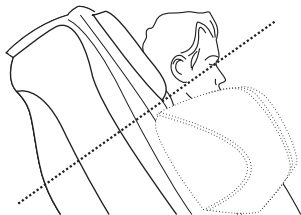

4. Adjust the position of the headrest.
 - Adjust the under-part of the headrest and align it with the position of the ear.

Remote Controller

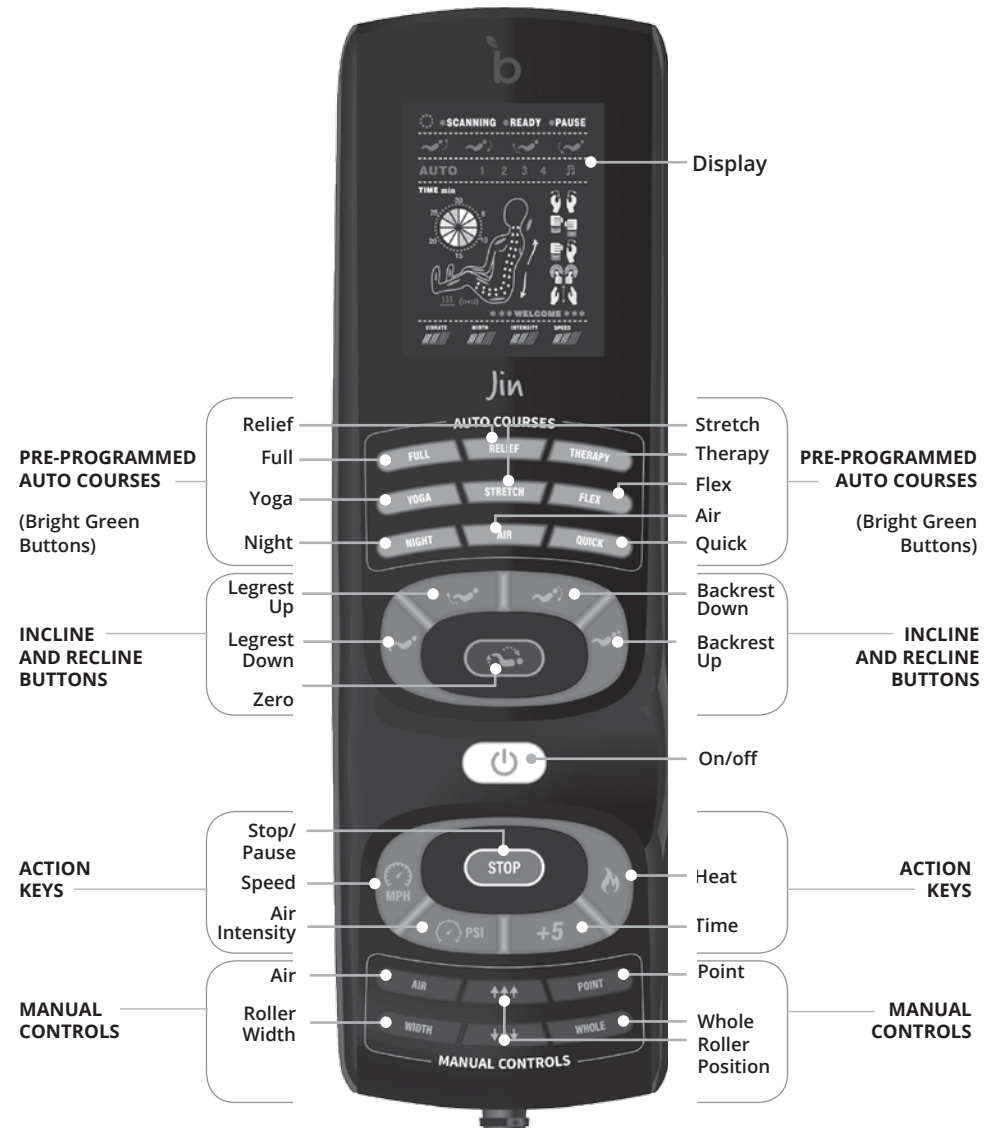

Operation Guide

FUNCTION DESCRIPTION OF CONTROLLER BUTTONS



Start or Stop massage chair

- Press this button to turn the massage chair ON. Now you can select an auto course or manual massage function.
- Press this button again to turn massage chair OFF. Massage function will stop and the massage chair will come back to the original position. When the chair returns to the original position the chair will completely shut off and all buttons will be inactive.



Press once to temporarily pause or stop all the massage functions. Chair will enter idle mode. Press again to resume massage.



Press this button to move the back and leg position. Press once for Zero G1, twice for Zero G2, three times for Zero G3 and four times to return to the original position.

Zero G1 → Zero G2 → Zero G3 → Original Position

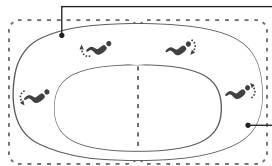

Press and hold this button to adjust the footrest.

Press and hold this button to adjust position of the backrest or legrest.

Note: The position adjustment buttons are disabled when the chair is in *STRETCH* mode.

Operation Guide

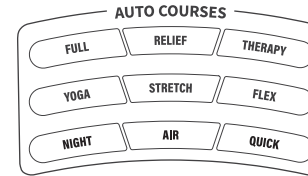

This chair is designed with 9 auto massage modes. FULL • RELIEF • THERAPY • YOGA • STRETCH • FLEX • NIGHT • AIR • QUICK

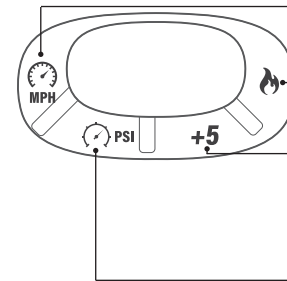

Speed – Press to cycle through three levels of speed: Tapping & Kneading, Dual Action & Shiatsu.

Heat – Press to turn heating function on and off.

Time – Press to increase the massage time in increments of 5 minutes. The default working time is 15 minutes. The maximum working time is 30 minutes.

Intensity – Press to cycle through three levels of intensity.



Air: Press this button for different combinations of massage.

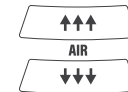

Roller Location: Press and hold the up or down arrows to move the massage rollers to the desired location.



Width: Press once to adjust the width of the rollers.



Point: Press to control the location of the massage roller, once pressed use the up and down arrows to position the rollers.

Kneading Point → Tapping Point → Dual Point → Shiatsu Point → Massage Point → Off



Whole: Press to manually choose the technique massaging the whole back.

Kneading Whole → Tapping Whole → Dual Whole → Shiatsu Whole → Massage Whole → Off

Operation Guide

DISPLAY DIAGRAM

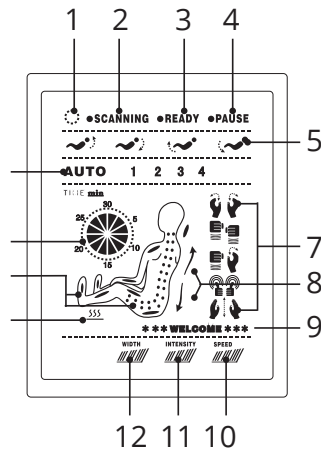

1. Power is on.
2. Massage chair is scanning the users back contour to provide a massage experience customized for the user.
3. Scanning is complete and the massage is about to begin.
4. Pause button has been pressed and the chair is temporarily stopped.
5. Reclining position adjustment buttons are pressed and the backrest and/or legrest are moving.
6. An Auto Course is activated.
7. Which massage technique is activated.
8. Direction of the massage rollers, moving upwards or downwards.
9. Cheerful greeting from your massage chair
10. Speed level, from one to three.
11. Air intensity level, from one to three.
12. Massage roller width, from narrow to wide.
13. Heating function is on.
14. Location of massage rollers and active air bags.
15. Time remaining in current massage program.

Operation Guide

AFTER USE

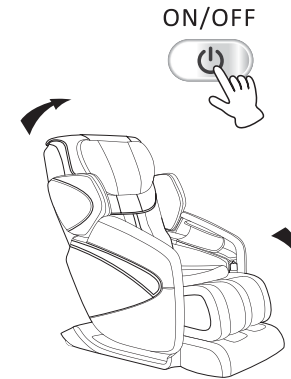

1. After the massage program is completed, return chair to upright position by pressing the On/Off button. Before pressing:
 - Make sure surrounding area is clear.
 - Keep arms and legs away from gaps between the armrest, legrest, and footrest, to prevent possible injury.



2. Then press the power button to turn off the massage chair and and bring it back upright. Once done, return remote controller to the storage pocket in the front of the chair by the users knee.



3. Turn off the main power switch.
4. Remove plug from power outlet.
 - Do not pull on the power cord to remove the plug.
 - Do not unplug with wet hands.

Maintenance

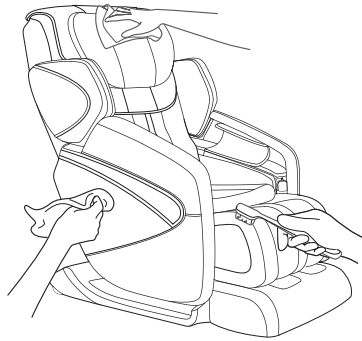

- Turn off and unplug the chair before cleaning.
- Use a dry, neutral colored cloth or soft bristled brush to lightly wipe the chair.
- Do not use water or any other liquids to clean the chair.

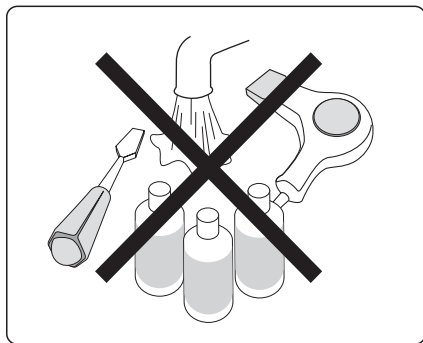
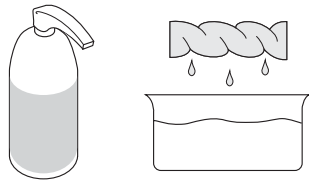

Any other servicing should be performed by an authorized service representative

Trouble Shooting

You may experience the following noises or feeling when in massage, as being due to the mechanical design, they will not have any effect on the operation of the unit and the product life.

- A “clatter” noise occurs when the knead balls go up and down.
- A “creak” noise of the gear and the motor occurs while in massage.
- A friction noise occurs when the knead balls rub the cover cloth.
- A rattling noise occurs while in the “Tap” or “Knead and Tap” massage movements (particularly when the massage moves from the shoulders to the back).
- In the “Knead”, “Tap”, or “Knead and Tap” massage movements, massaging speed may vary with the knead balls’ strength changed.
- A roaring noise of the motor occurs when load is given to the chair.
- A “cuckoo” noise occurs while in the auto mode course, the knead balls are automatically adjusted to the back-and-forth position to have the chair fitting in with the user’s body shape.
- The compressor’s noise and the air exhausting noise occur while in air-massage.
- A noise occurs when the air bag is inflated.
- A noise occurs while in massage of the shoulders.
- A grinding noise occurs when the backrest is reclined.
- There is a humming sound from the pump.





Warning

Absolutely do not modify, disassemble or repair by yourself. Negligence may cause fire or mechanical trouble of the chair which may result in hazard on the body.

Avertissement

Évitez absolument de modifier, de démonter ou de réparer le fauteuil vous-même. La négligence peut entraîner un incendie ou des troubles mécaniques du siège et poser un risque de blessures.

Trouble Shooting

PROBLEMS	CHECK POINTS	TROUBLESHOOTING
The unit does not start up.	Check whether the switch has been turned on.	Turn on the switch.
	Check whether the  button on the remote controller has been pressed.	Press the  button on the remote controller.
	No massage function has been selected.	Select a massage function.
	Check whether there is poor connection between the power plug and the receptacle.	Ensure good connection between the power plug and the receptacle.
Different height of the left and right knead balls.	A mechanism is used to allow two knead balls tapping alternatively.	This is normal and does not come from the trouble of the chair.
Sudden noise rises during operation.	Check whether the unit has been in operation for too long.	Turn off the power and stop the operation. Restart the unit after 30-min break.
Sudden cease of operation.	The rated operating time has elapsed.	Turn off the power and stop the operation. Restart the unit after 30-min break.
The reclined backrest fails to return its stored position when  is pressed.	Excessive use of the unit.	Turn off the power and stop the operation. Restart the unit after 30-min break.
	The rated operating time has elapsed.	
The power indicator fails to light up after the power switch is turned on.	Check whether there is poor connection between the power plug and the receptacle.	Ensure good connection between the power plug and the receptacle.
	Whether the circuit breaker is tripped off.	Restore the circuit breaker. If the problem re-occurs after the circuit breaker is restored, please contact our service center.



Attention

After checking, if the problem is caused by none of the above, switch off the power, unplug the power cord, and contact your dealer or our service center for repairs.

Prior to operating the unit when it has not been used for a long period of time, read this manual carefully and make sure that the unit is still in good condition to avoid accident or injury.

Avis

Après la vérification, si la source du problème n'est aucune de celles ci-dessus, coupez l'alimentation, débranchez le cordon d'alimentation et contactez votre détaillant ou notre centre de service pour faire réparer le fauteuil.

Avant d'utiliser le fauteuil s'il n'a pas été utilisé pour une longue période, lisez ce manuel attentivement et assurez-vous que le fauteuil est encore en bon état afin d'éviter les accidents ou les blessures.

