

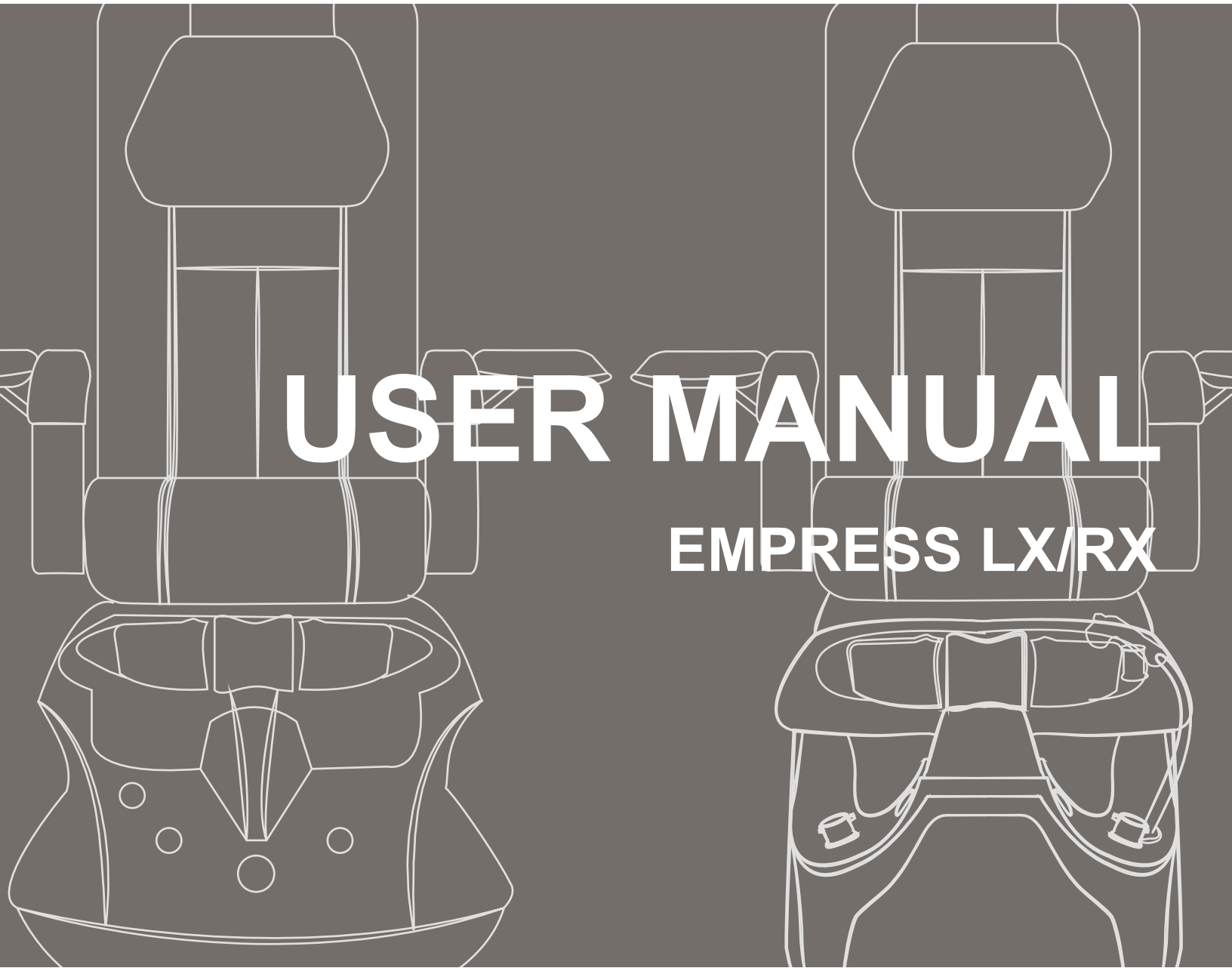

EMPRESS

USER MANUAL

EMPRESS LX/RX



Empress LX/RX: Specification

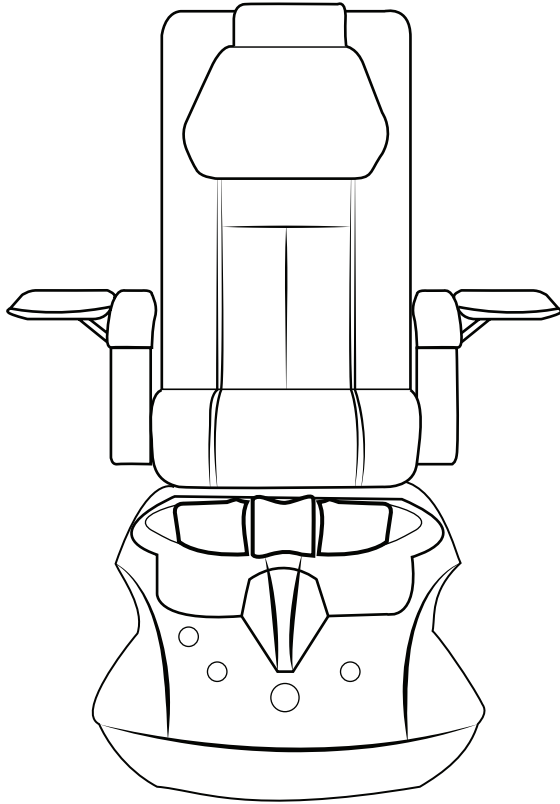

Empress RX

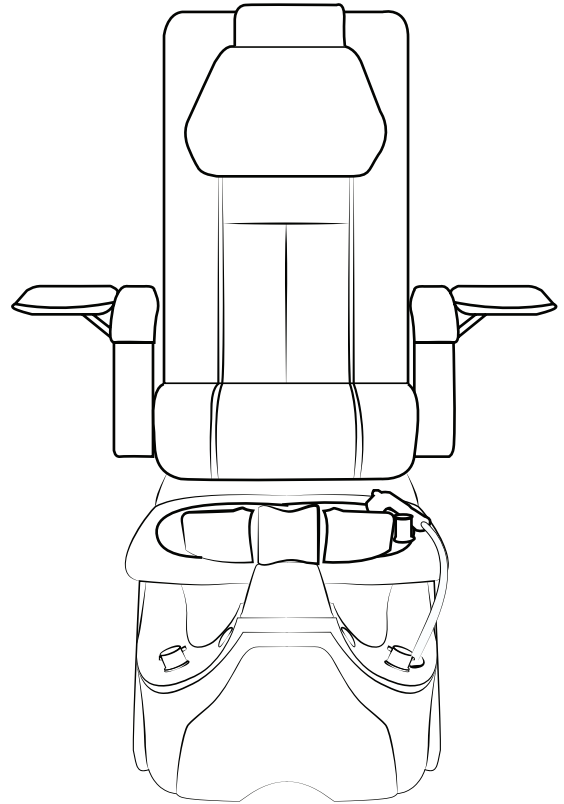

Empress LX

Dimension & Weight (Shipping)	Empress RX	37"W x 66"L x 40"H	275lbs
	Empress LX	37"W x 66"L x 40"H	305lbs
Dimension & Weight (Net)	Empress RX & Massage Chair	28"W x 54"L x 32"H	192lbs
	Empress LX & Massage Chair	28"W x 52"L x 32"H	224lbs
Capacity of Tub	4.5 US Gallon		
Switch	On/Off Air Activated Switch		
Power Source	Dedicated 15Amp Wall Outlet Require Pipe-less Whirlpool Motor Discharge Pump (Optional) Massage System	120Vac, 0.4 Amp, 60Hz 120Vac, 60Hz Input: 100-240V 50-60 Hz 1.6A Output: 24V 2.5A	
Plumbing	Hot Water Cold Water Drain	0.5inches (Fitting Provided) 0.5inches (Fitting Provided) 1.5inches (See Plumbing Instruction)	
Warranty	See detail in warranty page.		

Installation Specifications Summary

WARNING: Failure to comply with federal, state or local codes and ordinances will result in warranty being null and void.

As stated, the pedicure spa installation must comply with all **plumbing and electrical codes**. A **licensed plumber and licensed electrician MUST** complete the applicable connections of the pedicure spa.

Location and support: Select a level location. The floor structure beneath the pedicure spa must be capable of supporting the occupied pedicure spa.

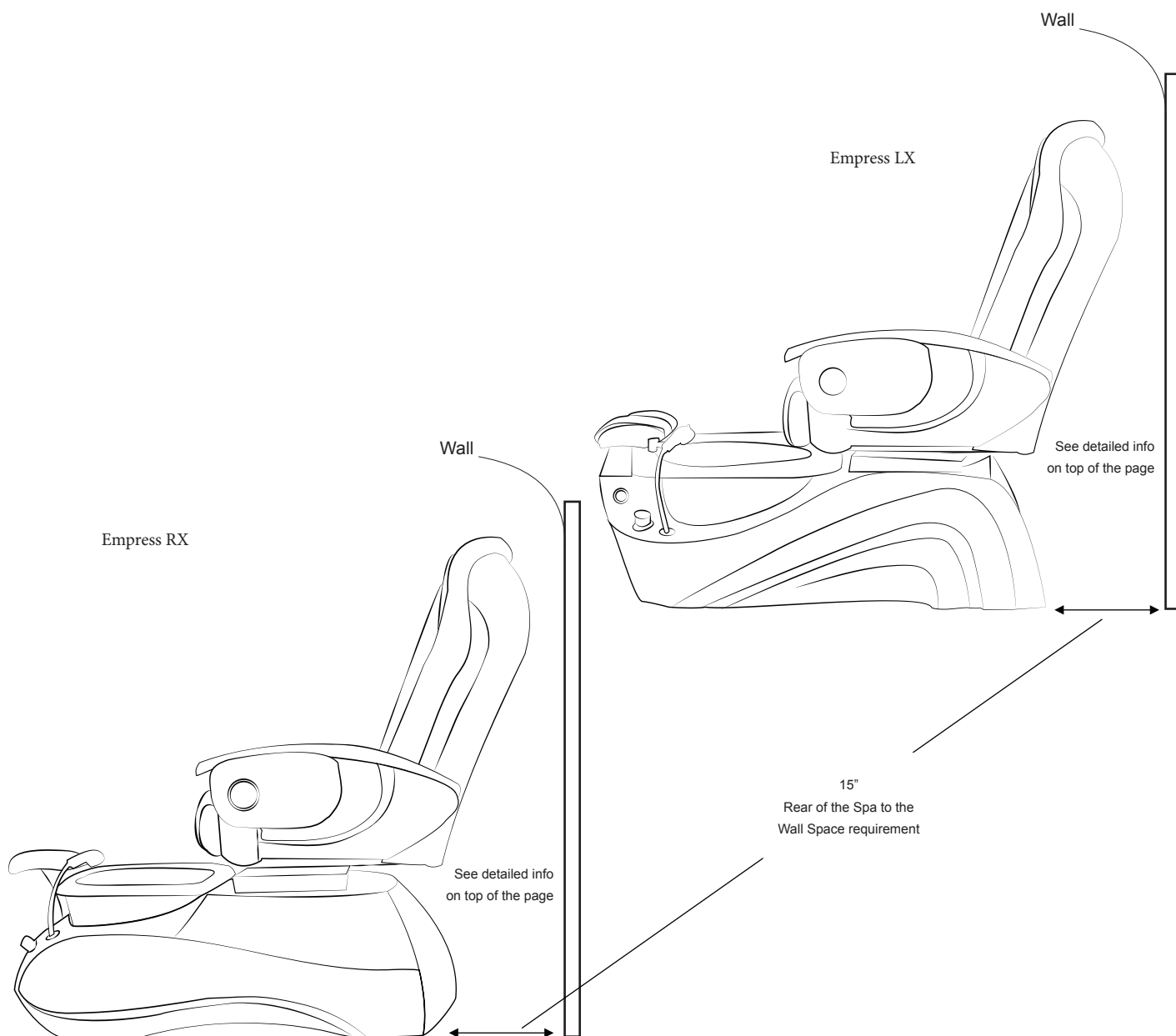

****Due to continuous improvements on all our products, specification, characteristics, packing, color, designs are subject to change without notice.**

Empress RX: Identification

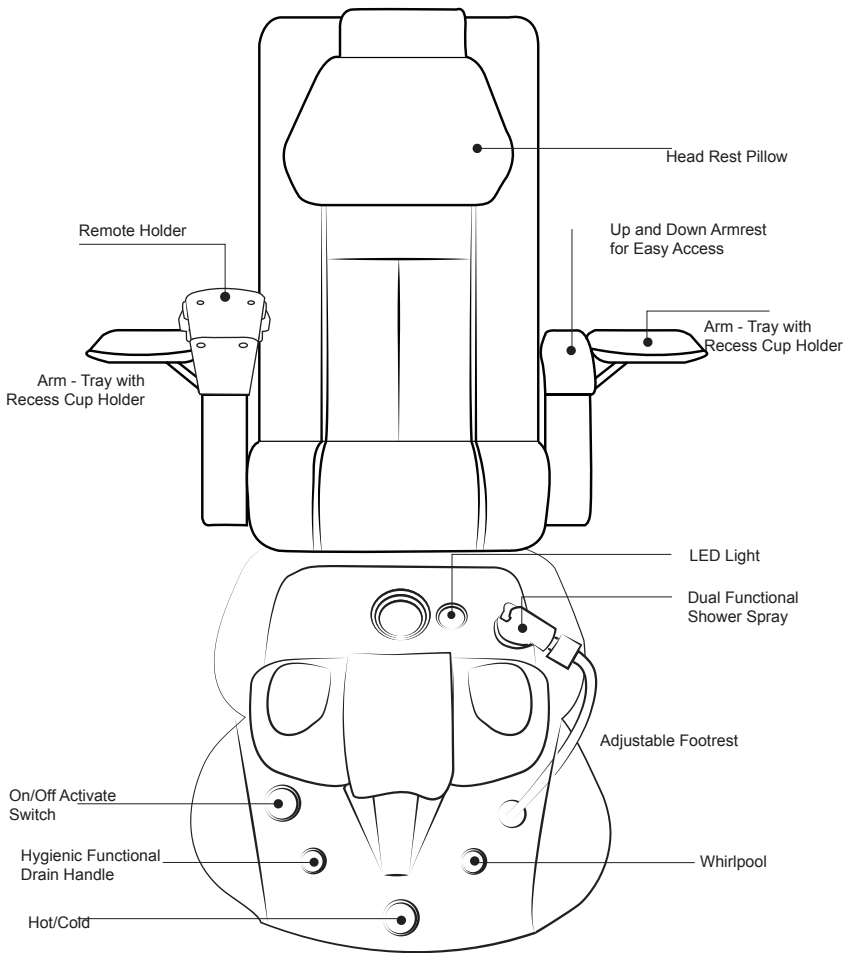

Rear View

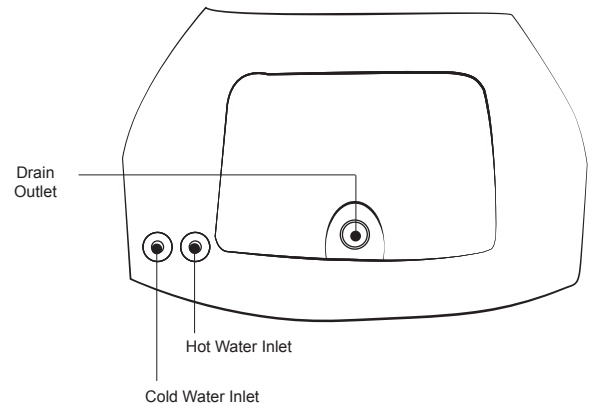

BASIN

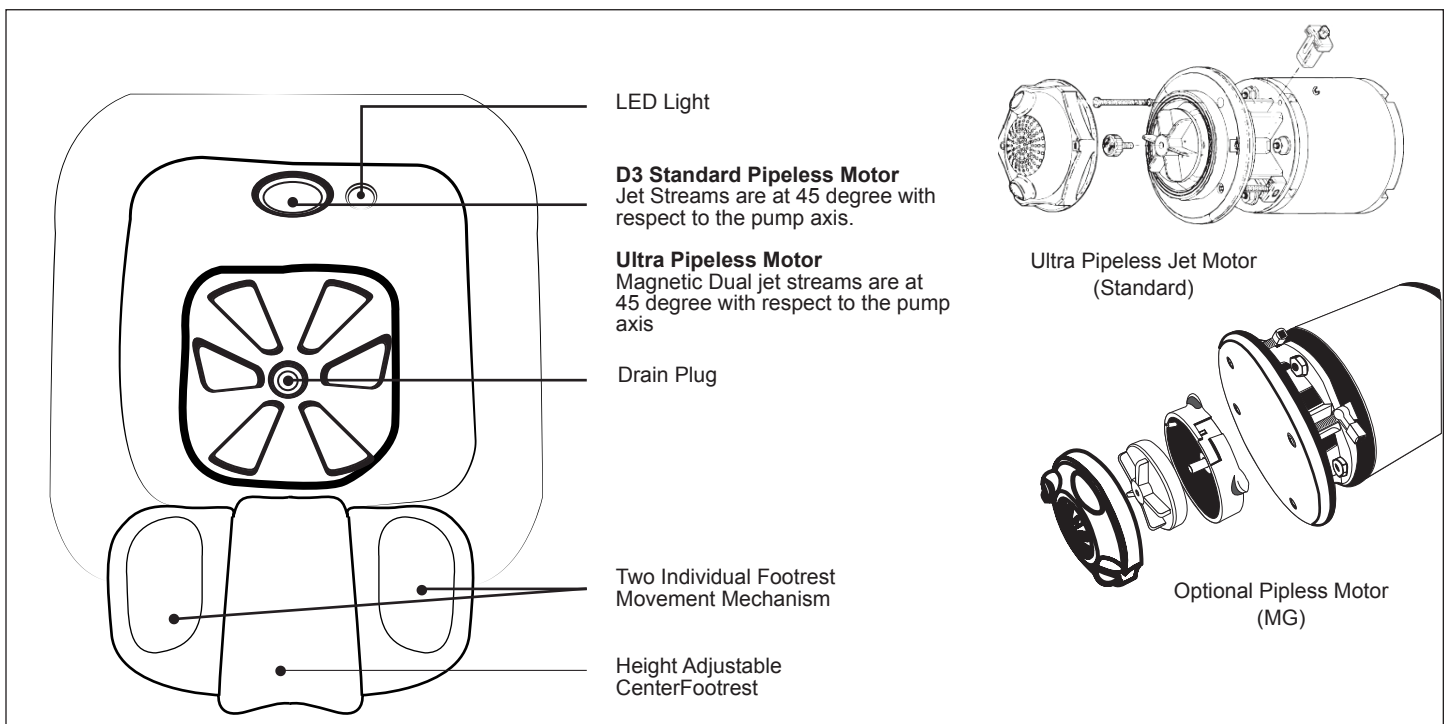

Empress LX: Identification

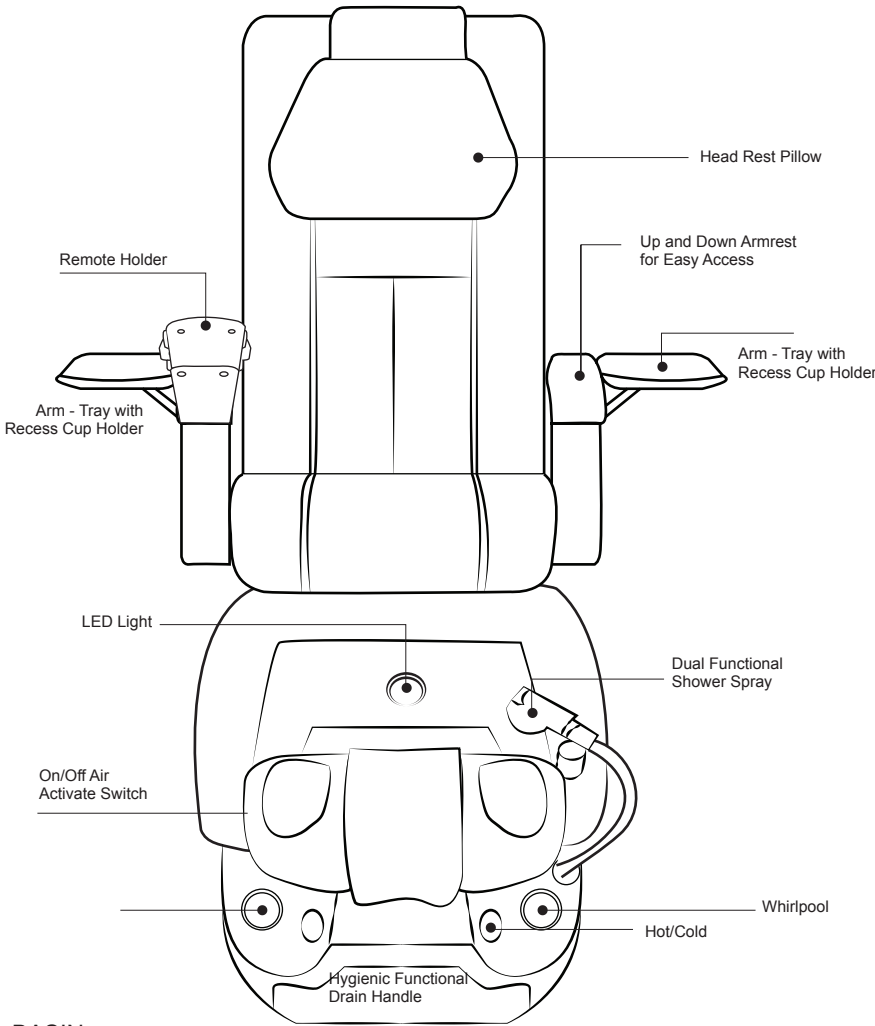

Rear View

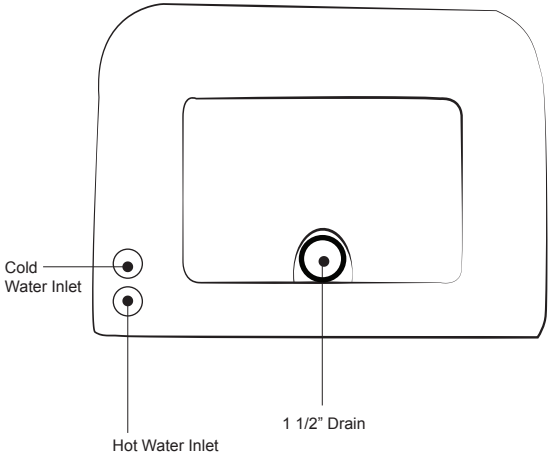

BASIN

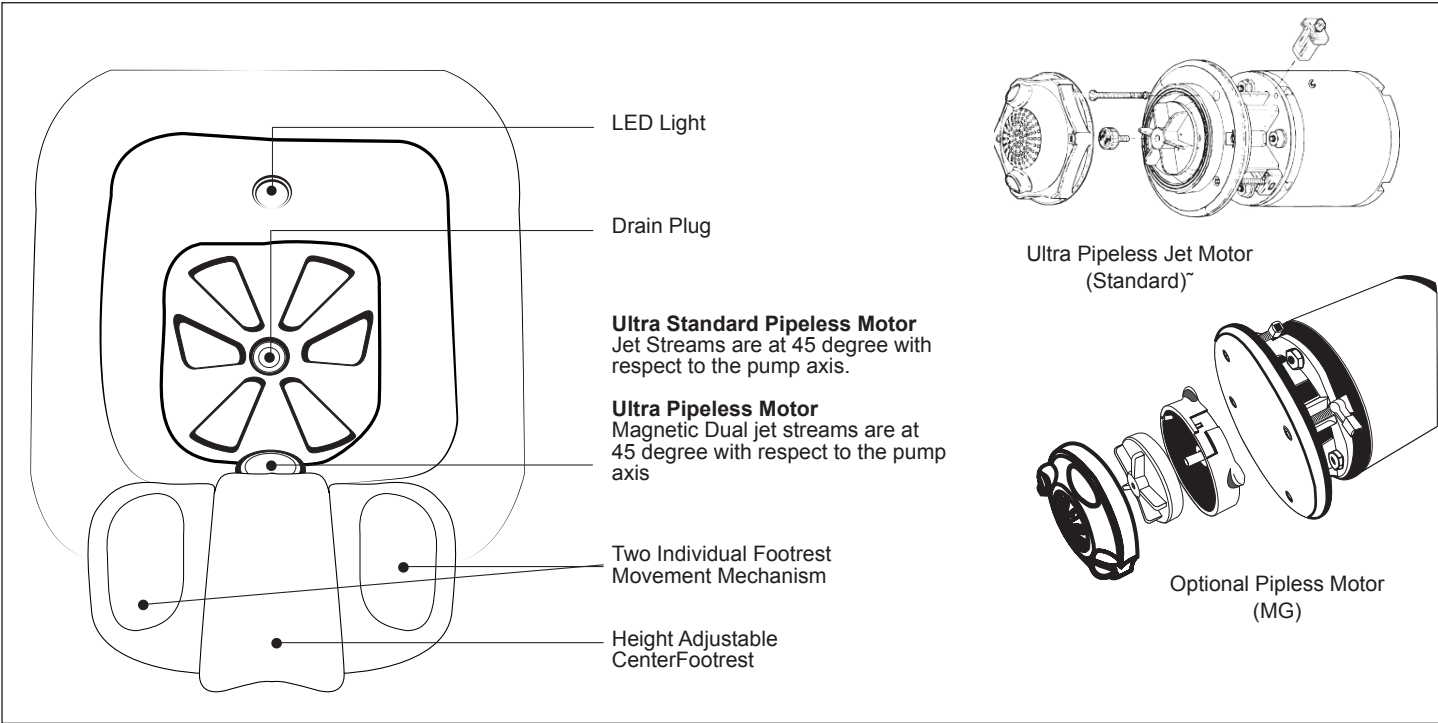

Empress RX: Dimension

Rear View

Wall drain outlet (1 1/2" PVC) Location/
Hot & Cold Inlet (1/2") Location

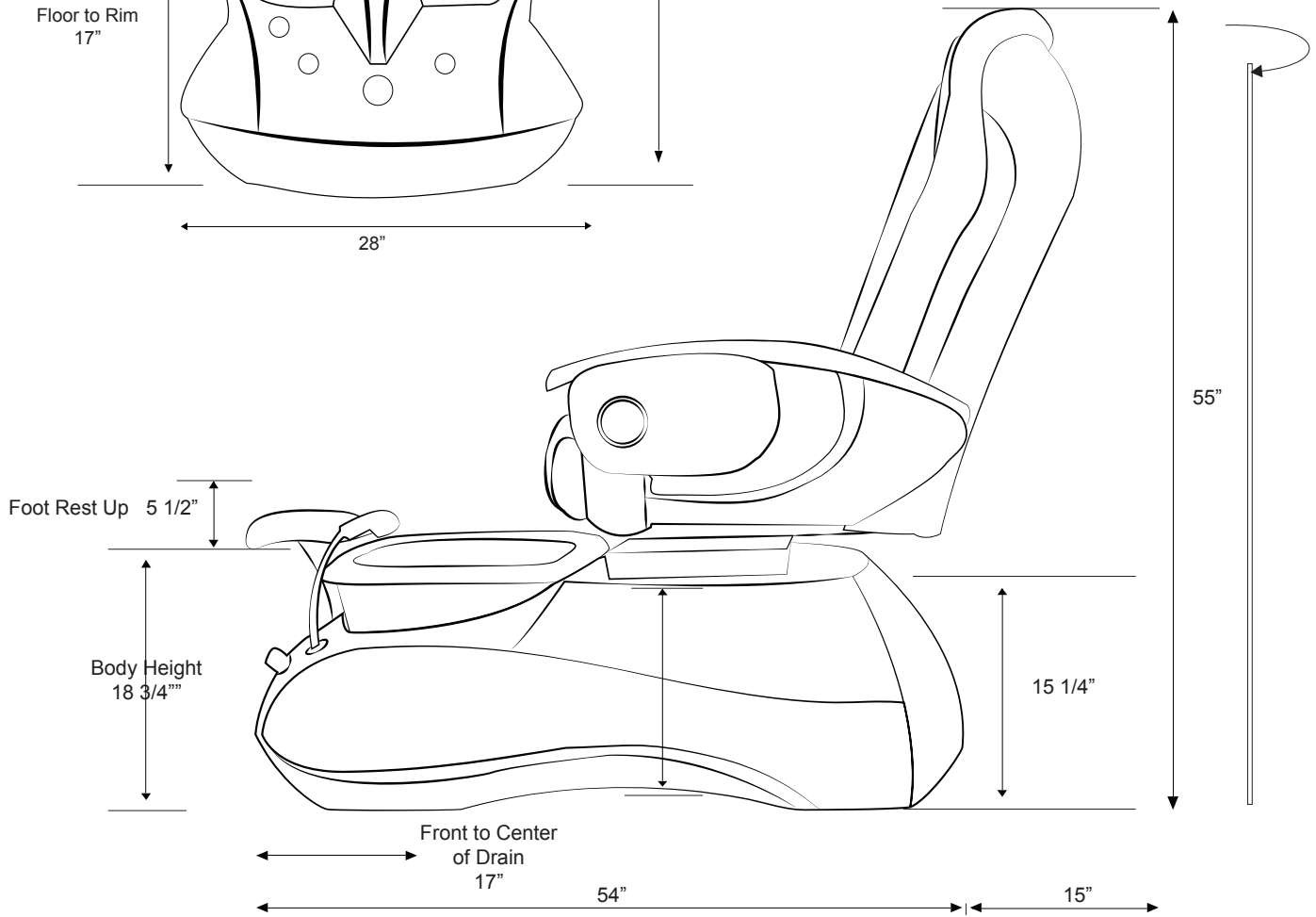
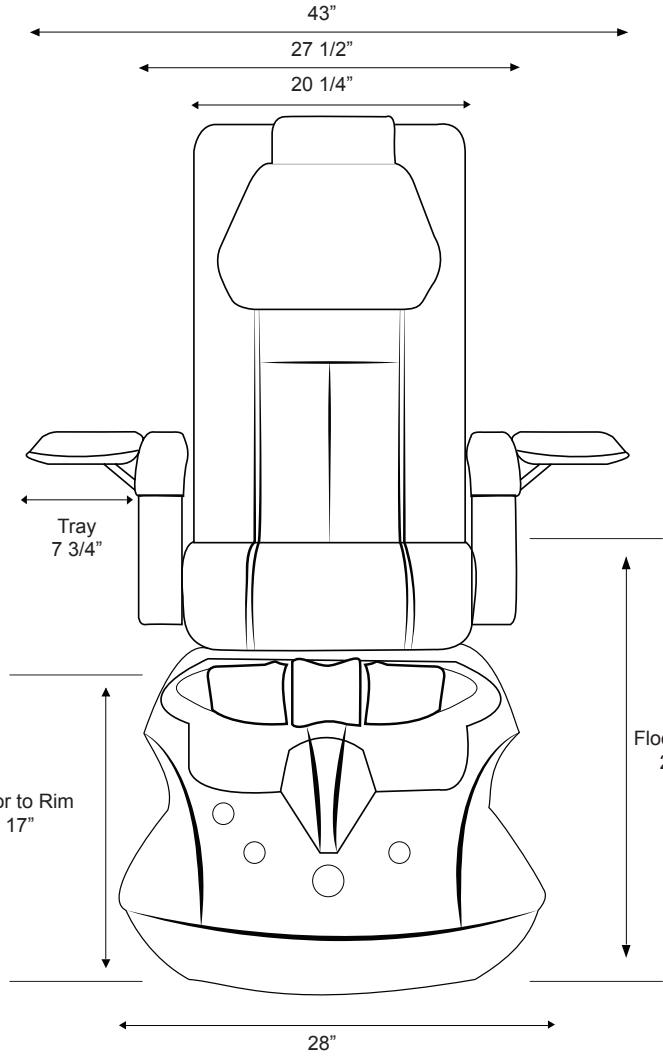
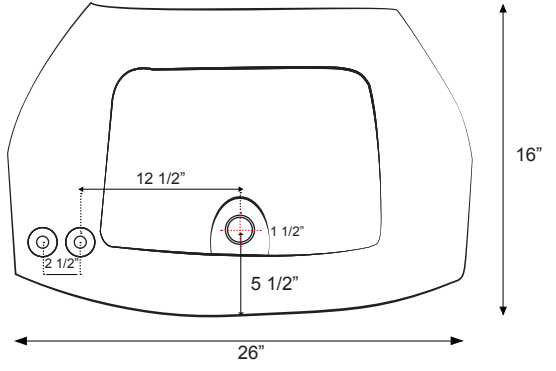

Empress LX: Dimension

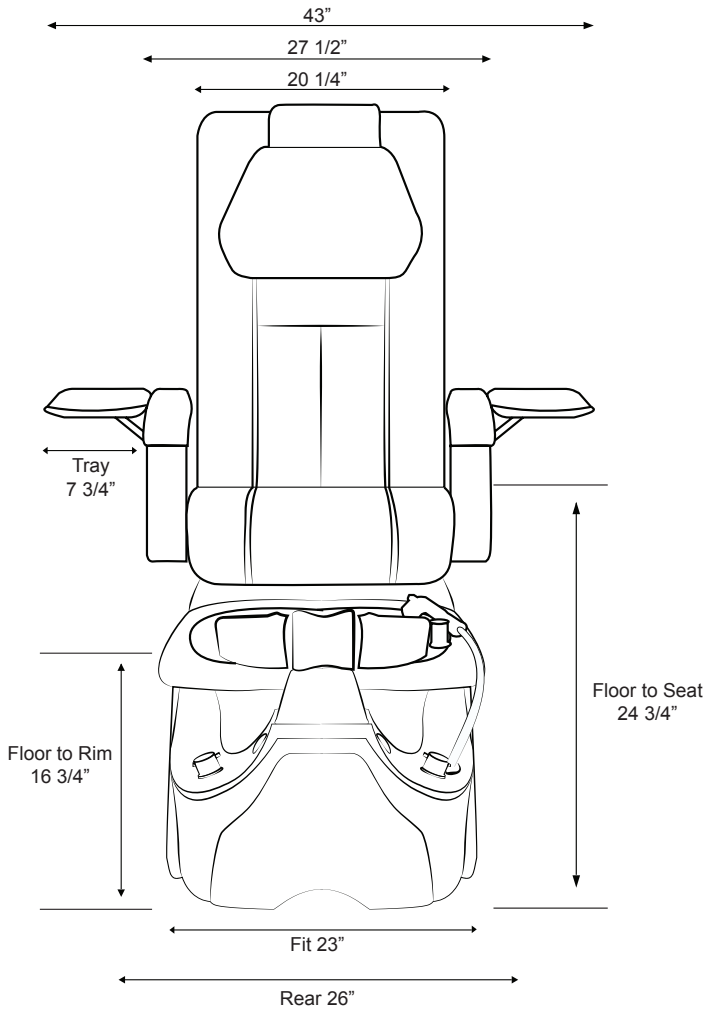

Rear View
Wall drain outlet (1 1/2" PVC) Location/
Hot & Cold Inlet (1/2") Location

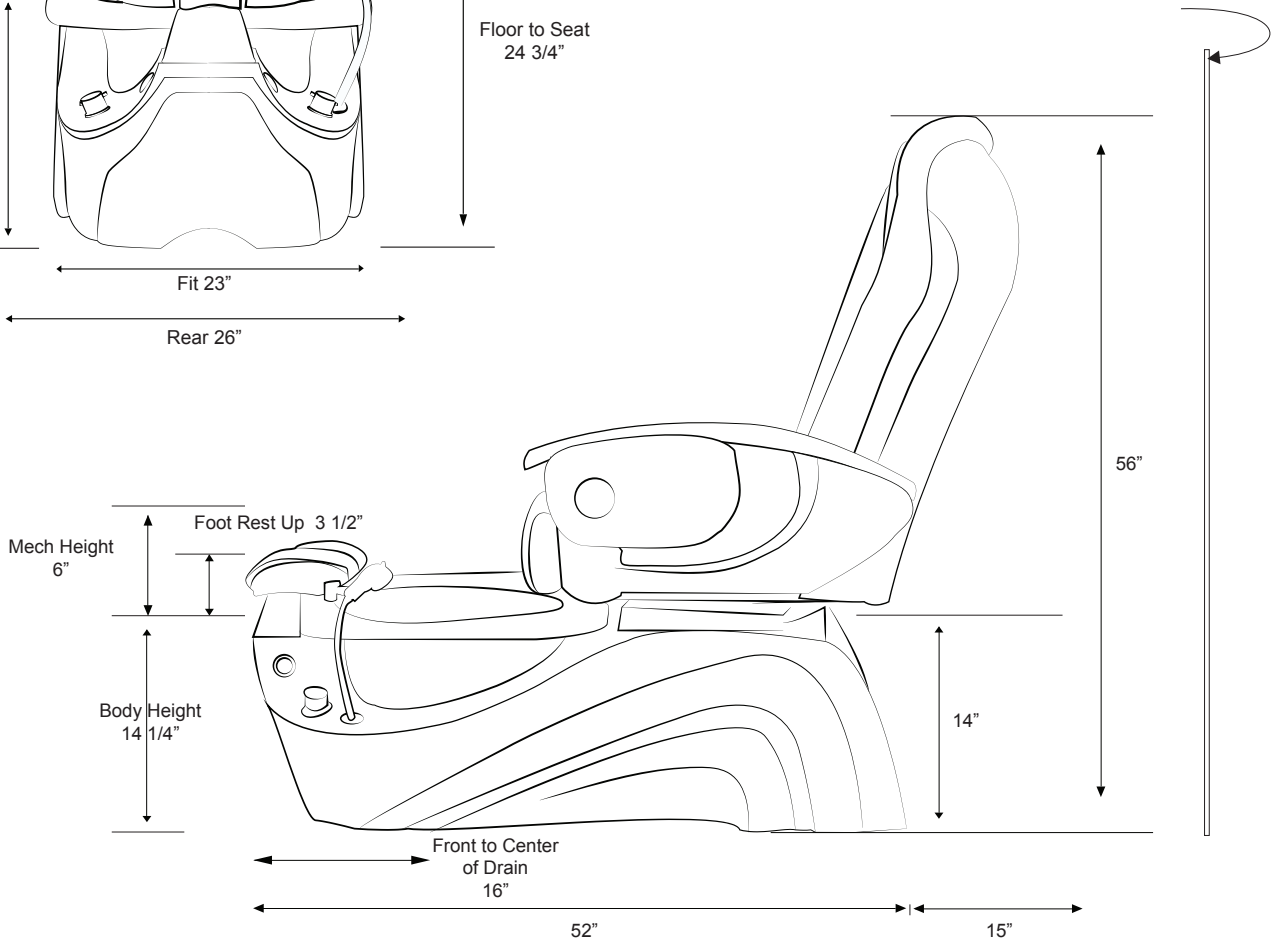
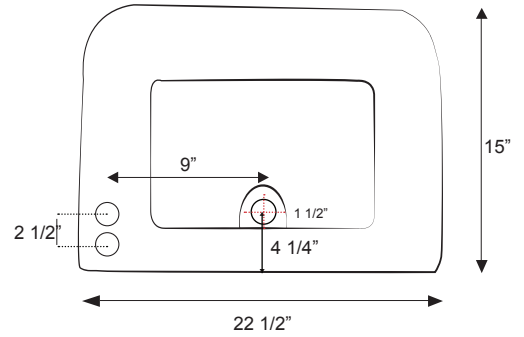

Empress RX: Drain

Wall Drain

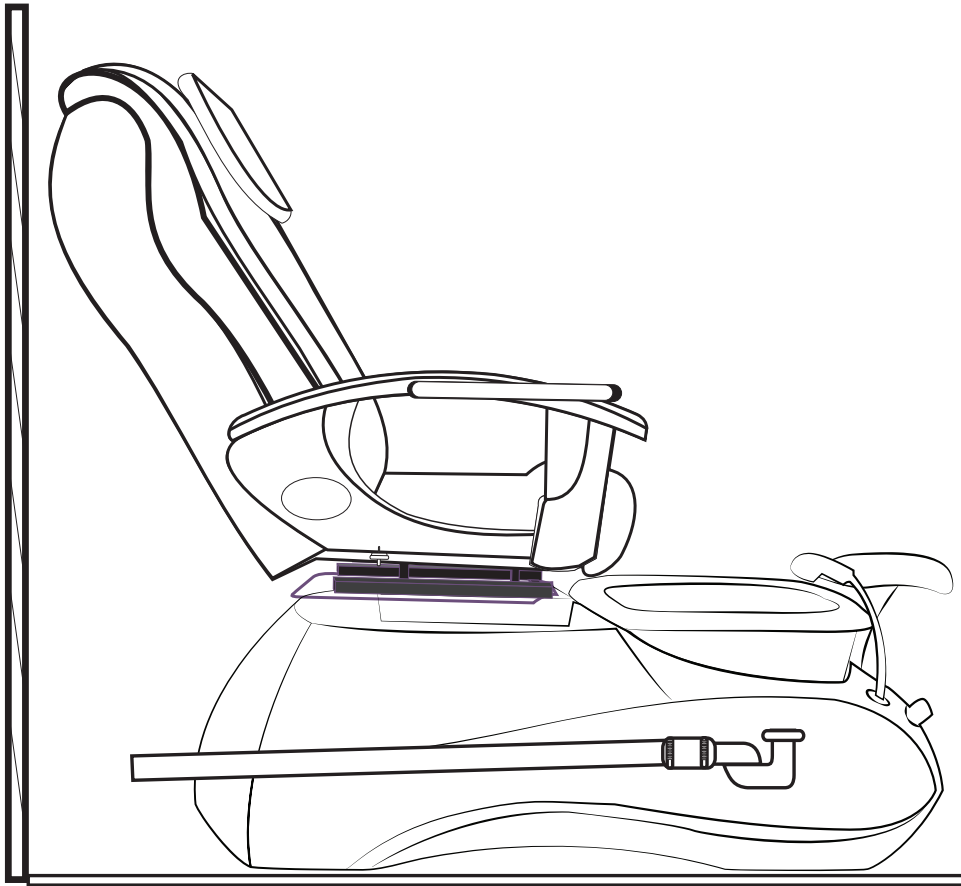

Power Drain
(See detailed power drain pump)

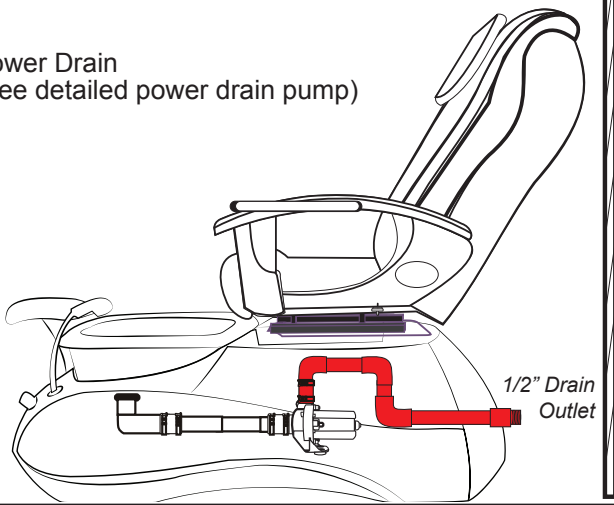

Basement Connection
(NOT recommended
on floor drain)

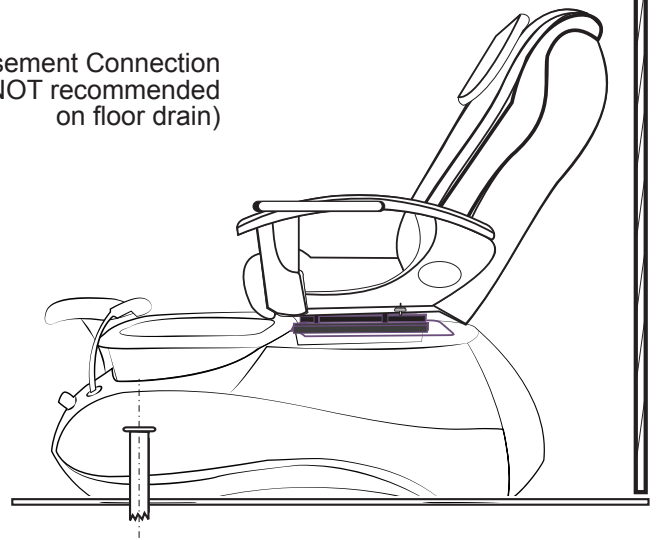

Empress LX: Drain

Wall Drain



Power Drain
(See detailed power drain pump)

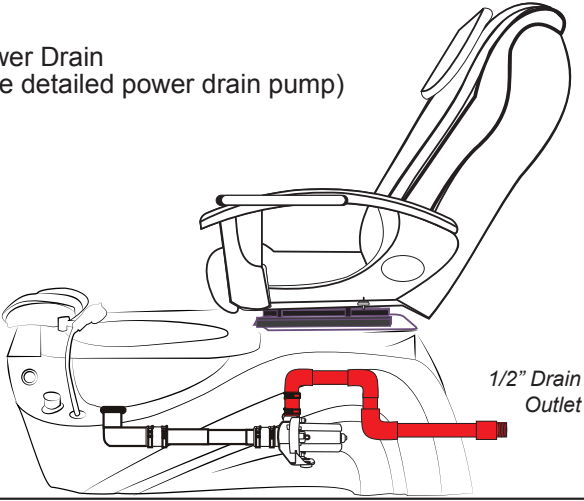

Basement Connection
(NOT recommended
on floor drain)

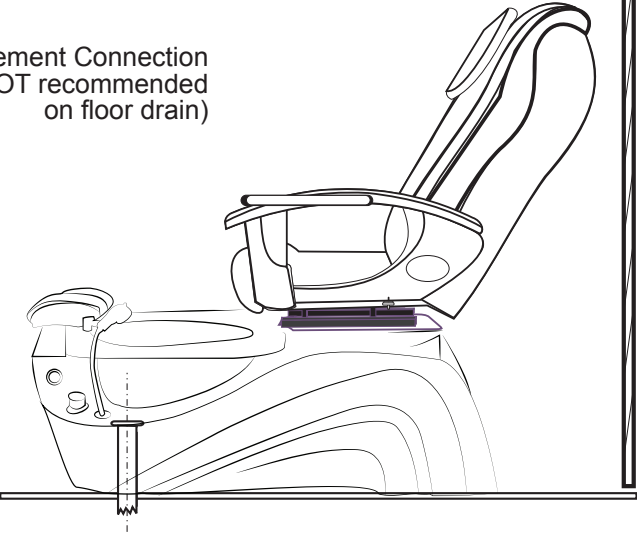

Empress RX: Discharge Pump (Optional)

Up to 4ft @ +/- 39 sec. with 1/2" Connection to main drain

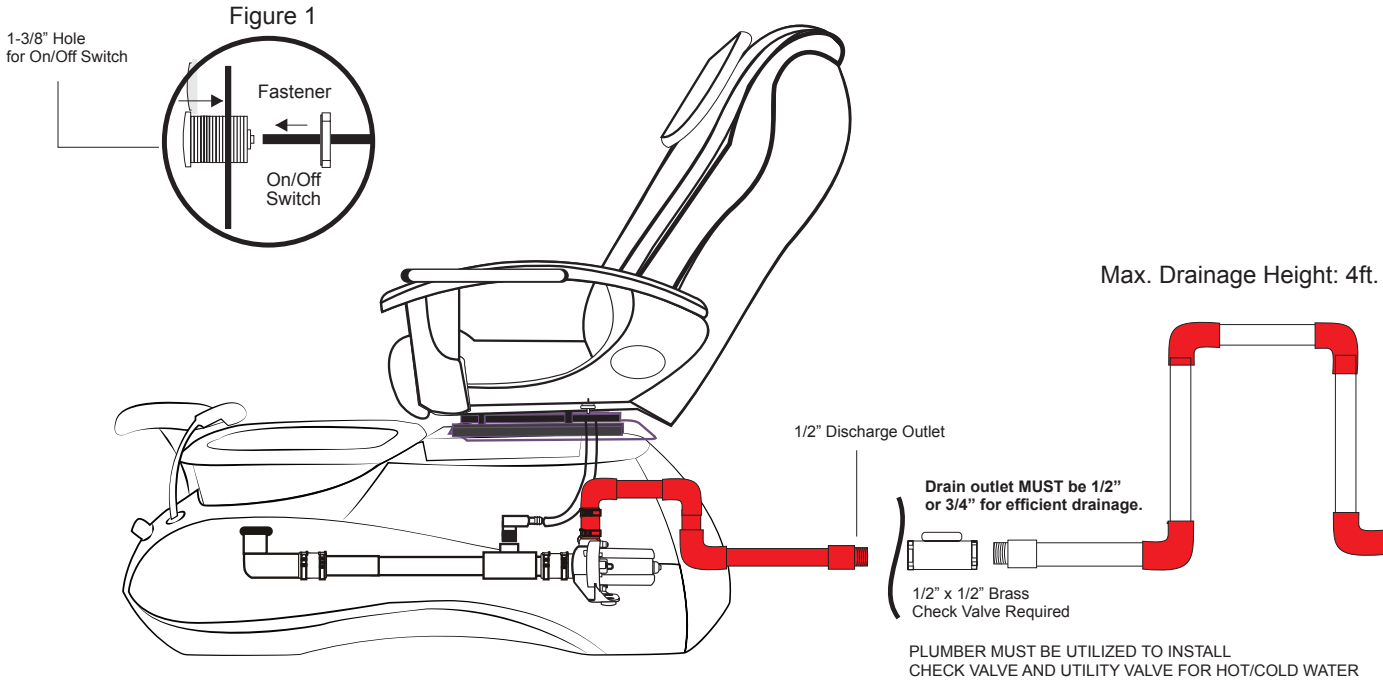
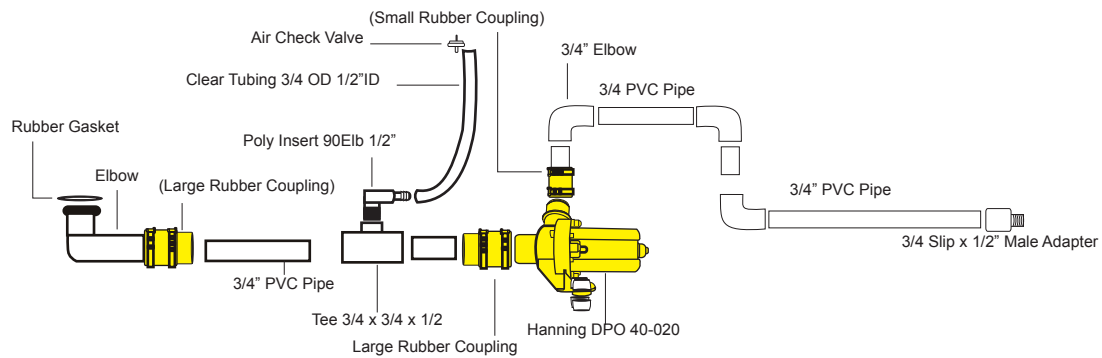

Figure 2



Installation Instruction:

1. Make a hole (size 1-3/8") for the On/Off switch as shown (see fig 1). Pre-drill required.
2. Placed a 1/8" clear hose into the rear of the switch and on/off switch into the hole.
3. The discharge pump kit is made to fit onto the pedicure unit. (See fig 2)
4. Connect E-Z connector onto the drain elbow.
5. Plug discharge pump outlet into the two minute timer outlet
6. Plug two minute timer into the wall outlet.
7. It is very important that tip of the clear tub remain above the water Level with one loop as shown.

Operation Instruction:

Warning ! DO NOT RUN DRY

1. Turn to open drain plug. 3 to 5 second for air to release from the pipe
2. Press On/Off switch to activate timer.
3. At any time, water drain completely from the basin. Press On/Off switch to stop or built in two minute timer.

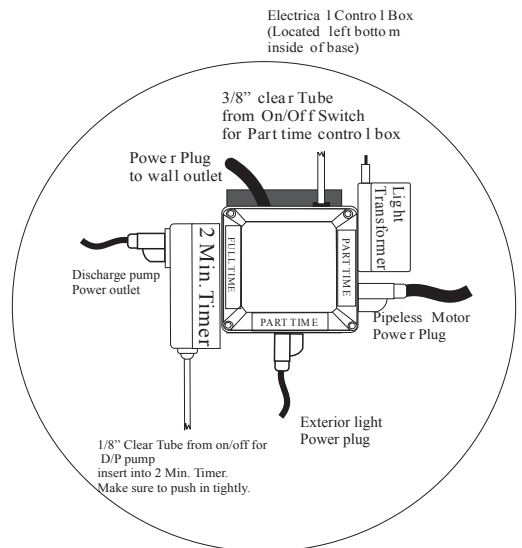

Empress LX: Discharge Pump (Optional)

Up to 4ft @ +/- 39 sec. with 1/2" Connection to main drain

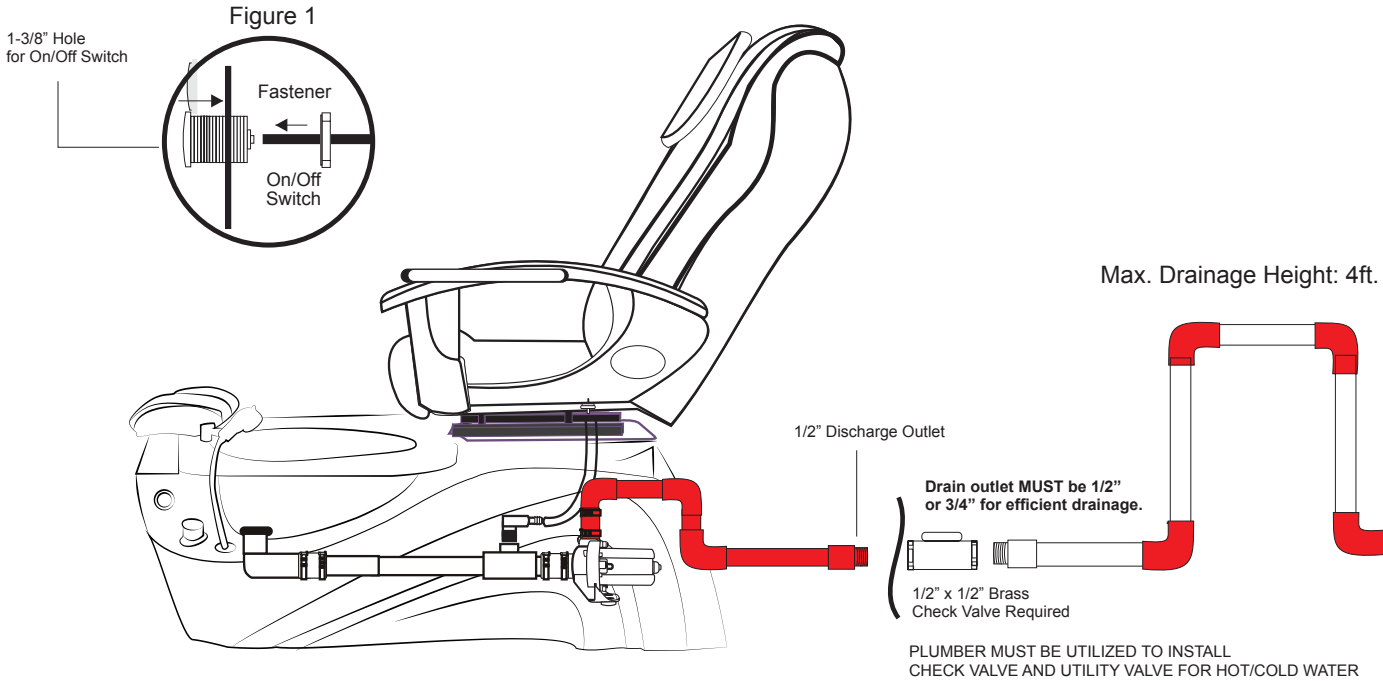
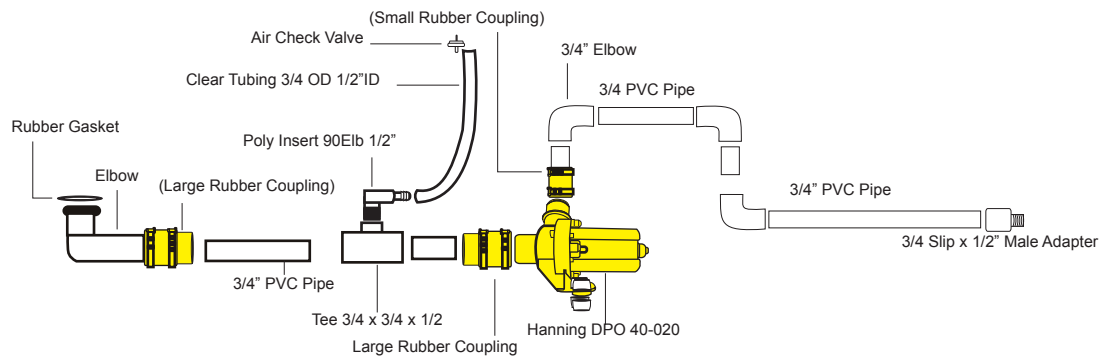

Figure 2



Installation Instruction:

1. Make a hole (size 1-3/8") for the On/Off switch as shown (see fig 1). Pre-drill required.
2. Placed a 1/8" clear hose into the rear of the switch and on/off switch into the hole.
3. The discharge pump kit is made to fit onto the pedicure unit. (See fig 2)
4. Connect E-Z connector onto the drain elbow.
5. Plug discharge pump outlet into the two minute timer outlet
6. Plug two minute timer into the wall outlet.
7. It is very important that tip of the clear tub remain above the water Level with one loop as shown.

Operation Instruction:

Warning ! DO NOT RUN DRY

1. Turn to open drain plug. 3 to 5 second for air to release from the pipe
2. Press On/Off switch to activate timer.
3. At any time, water drain completely from the basin. Press On/Off switch to stop or built in two minute timer.

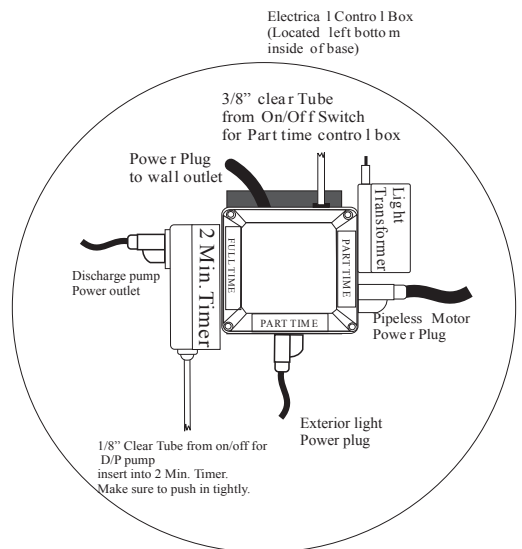

Ultra Jet Whirlpool Motor

Safety Instructions:

When using electrical equipment, basic safety precautions should always be followed to reduce the risk of fire, electrical shock, and injury to persons, including the following:

1. Read and follow all instructions before using the equipment.
2. Keep the cord out of heavy traffic area. To avoid fire hazard NEVER put the cord under the rugs, near heat generating devices.
3. Always turn off the equipment before servicing.
4. Do not drop or insert any object into any openings.
5. Do not operate any equipment with a damage parts.
6. Any other use not recommended by the manufacturer may electrical shock or injury to persons.
7. Never use outdoors
8. Do not attempt to repair or adjust any electrical or mechanical functions on the unit.

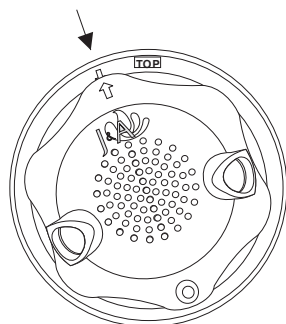

Close Jet Cover

1. Align an arrow line
2. Turn to right (Top indicated)

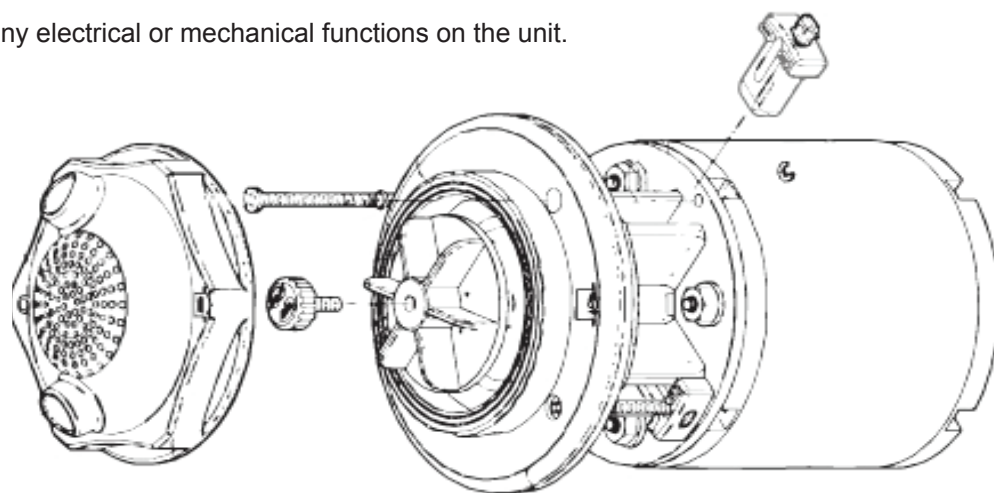
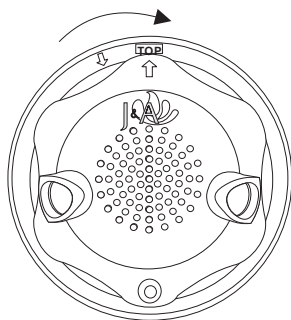

Features:

1. Dual powerful massage jet-streams
2. Jet assembly can be attached from the pump for quick cleaning and sanitizing.
3. Thermally Protected
4. AC motor (long life)
5. Extremely low power consumption .

Cleaning Instruction:

1. Turn the unit off and wait until the motor is fully stops.
2. Remove the front jet cover and notice the locking screw in the center
3. Remove the locking center screw (Indicated an Arrow) and pull out impeller from housing.
4. Use Anti-Bacterial solution (EPA Registered) to clean all part/s.
5. After sanitation, place impeller onto the motor shaft and fasten with center locking screw (Opposite arrow)

Ultra Pipeless Jet Whirlpool Motor Specifications:

Model: CS-0216A-MT

Rating: 120VAC / 60Hz, 0.4A - thermally Protected

Pump: Dual whirlpool Jet Flow

Mounting: Single 3.5" hole Diameter

Auto tighten Mounting screws(4)

Magna-Jet (Optional)

Safety Instructions:

When using electrical equipment, Basic safety precautions must be followed to reduce the risk of fire, electrical shock, and injury to Persons.

1. Read and follow all instructions before using the equipment.
2. Keep electrical cord out of heavy traffic area. To avoid fire hazard NEVER place electrical cord under the rug, near heat Generating devices.
3. Always turn power off the equipment before service.
4. Do not drop or insert any object into any openings.
5. Do not operate any equipment with damaged parts.
6. Any other use not recommended by the manufacturer may cause electrical shock or cause injury to person/s.
7. Never use it outdoors
8. Do not attempt to repair or adjust any electrical or mechanical.

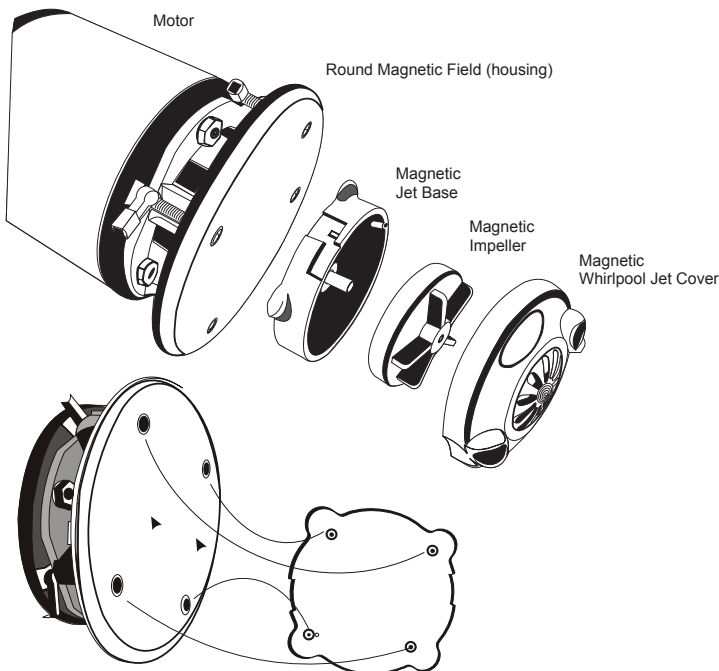

MAGNA JET Features:

1. Hydro dual massage jet stream
2. Magnetic whirlpool jet cover can be remove for quick cleaning and sanitizing.
3. Built-In electronic sensor for pump control.
4. AC Whirlpool motor (long life)
5. Very low power consumption (27W)
6. Manufactured in USA.

Cleaning Instruction:

1. Turn off the unit and wait until the motor is fully stops.
2. Hold hydro whirlpool jet cover firmly and pull to separate from the round magnetic field.
3. Turn hydro whirlpool jet cover to left to open and pull out impeller.
4. Use Anti - Bacterial solution (EPA Registered) to clean all parts.
5. After sanitize all parts, place impeller and close hydro whirlpool jet cover to turn right to lock
6. Hold firmly the whirlpool cover jet and gently place it onto the round magnetic field. Do not release the hydro whirlpool jet cover until jet cover is on the round magnetic housing.

MAGNA-JET Specifications:

Model:MAGNA-JET-120 VAC, 60HZ, 1.0Amp

Pump: Hydro-Massage Dual Air Jet Flow

Mounting: Single 3.5" Hole Diameter Auto Tighten Mounting Screws(4)

How to USE Magnetic Jet!

WARNING: DO NOT RUN DRY, BASIN MUST FILLED WITH WATER TO LEVEL INDICATOR.

CAUTION: MAGNETIC JET COVER ASSEMBLY MUST ALIGN WITH DISCHARGE PORT POSITIONED AT 3/9 O'CLOCK.



When Ready to use, **MAKE** sure jet cover is positioned at 3/9 O'clock for proper whirlpool action in the basin. If jet cover is not align at 3/9 O'clock, water will splash outside of the basin.

Proper way to use Magnetic Jet System:

1. Fill the water to water level indicator.
2. Hold Magnetic Jet firmly to bring closer to the round magnetic field and do not release the Magnetic Jet prematurely or this will cause impacts on the jet cover and the round magnetic field(housing) shortening the life expectancy of the jet cover. When the jet cover nears the round magnetic field, place jet cover onto the four dimple area (see diagram). The jet cover must align with discharge ports positioned at 3/9 O'clock.
3. When finished with client, DO NOT remove Magnetic Jet until motor is fully stopped.
4. When motor is fully stopped, remove Magnetic Jet cover from the motor and remove jet cover and impeller for sanitation.

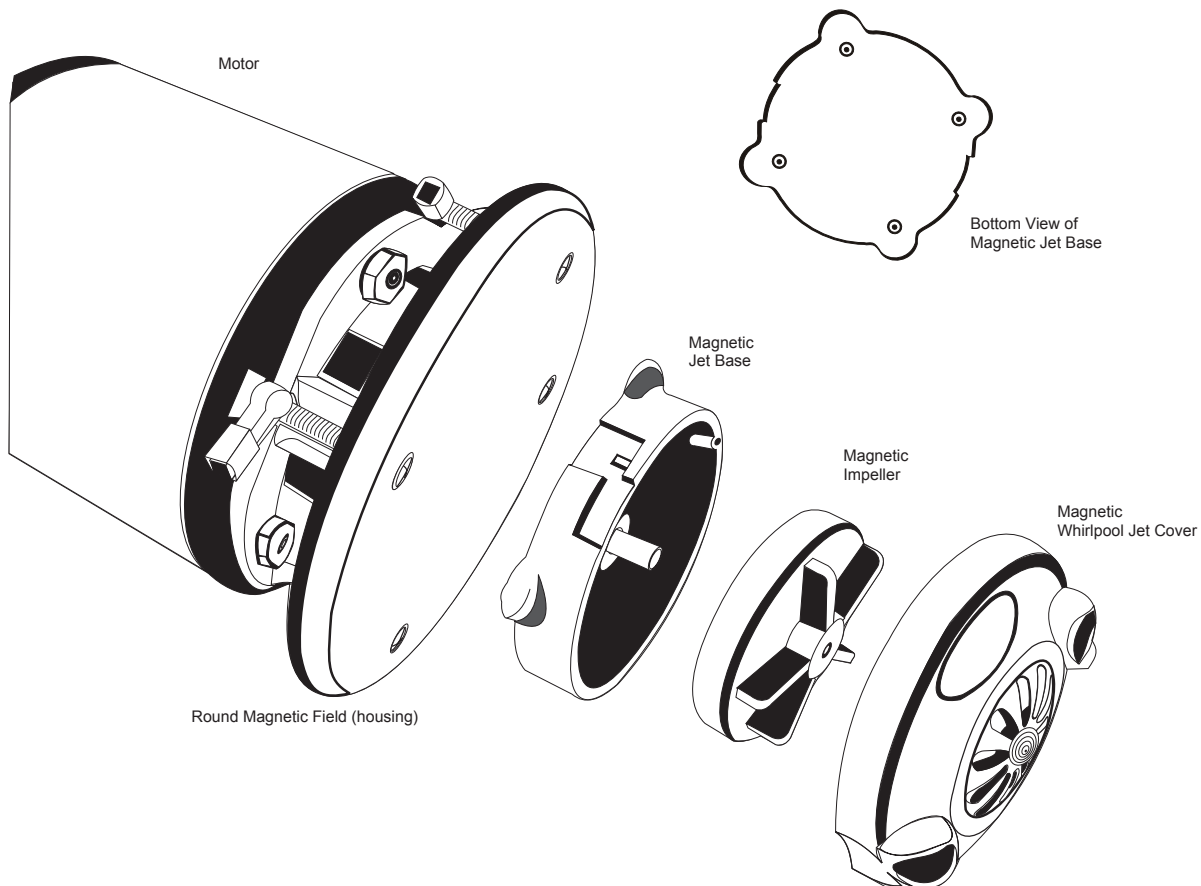

Auto Fill System (Optional)

Feature & Operation

- a. Automatic spa fills with intelligent and reliable level sensor.
- b. Time delay setting
- c. Dual switched outlets/ Control box
- d. Dual continuous outlets
- e. Single drain pump controlled outlet with 3 minute timer (If drain pump requested as an option)
- f. Heavy duty water valve
- g. Operated in automatic or manual mode
- i. Built in LED light power supply
- j. Audible overflow warning in manual fill mode

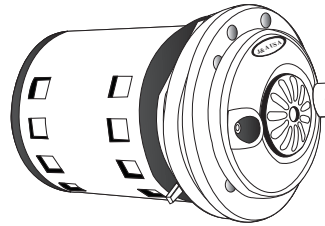

Dura Jet III Built - in Electrodes Water Sensor

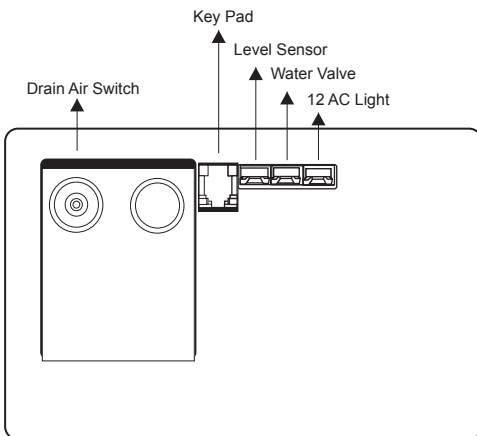
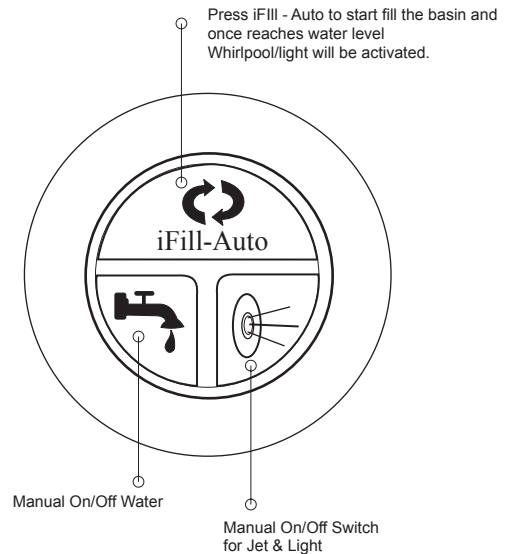
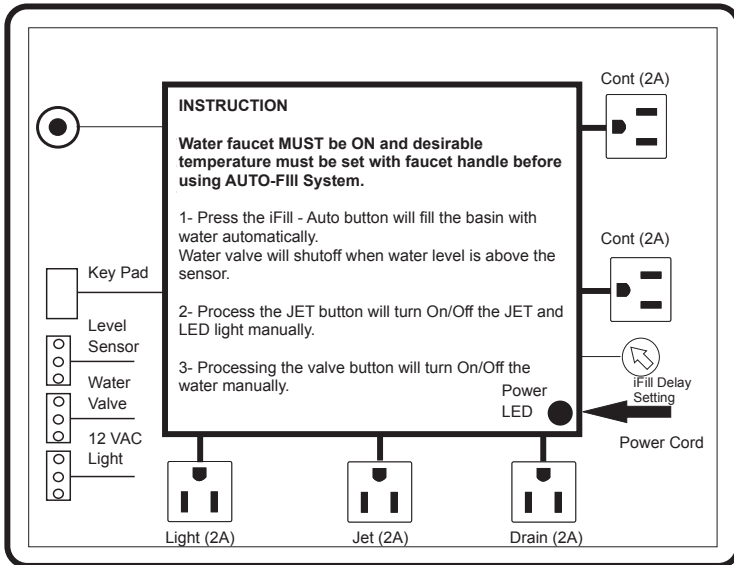

ALL WIRES ARE INDICATED AS IT SHOWN

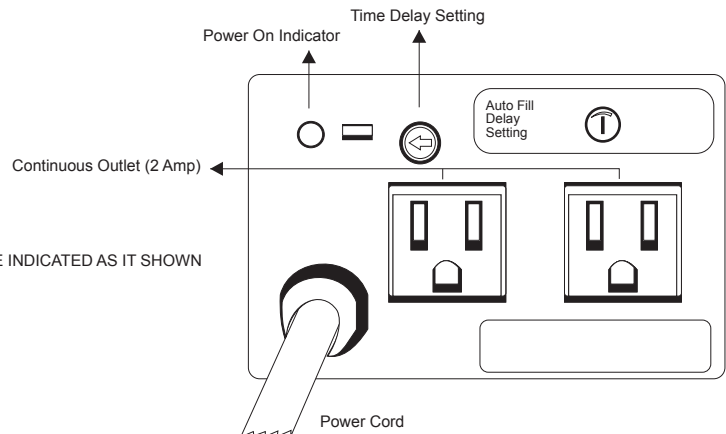

Placing Backrest in Correct Position

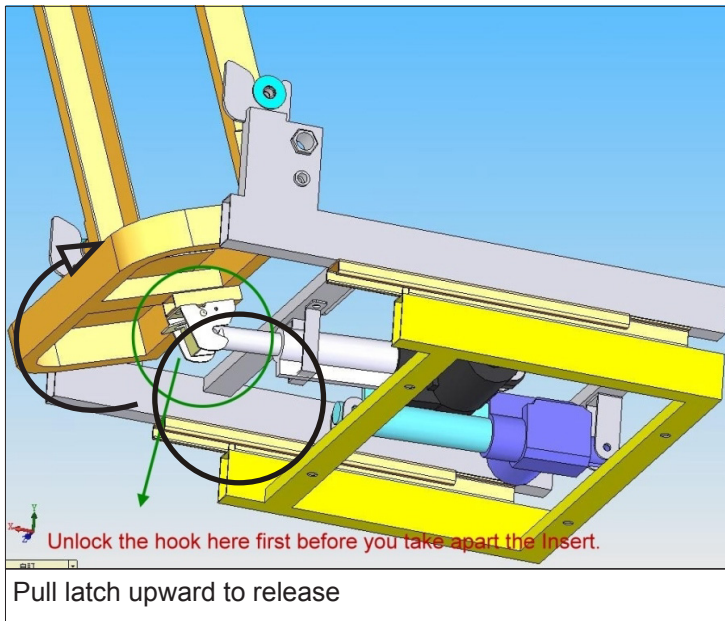

Detachment of Backrest

- Pull latch lever upward to release from recliner piston.
- As arrow indicates, bring backrest to fold onto the seat.
- Disconnect all cables (recliner, slider).

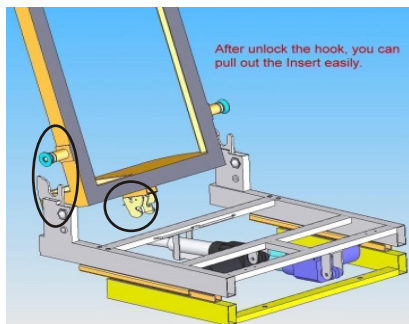

Attachment of Backrest

- On the lower portion of both side of the backrest, there are pivots.
- Align both pivots correctly so they rest perfectly onto the “U” pivot frame.
- Once both pivots sit snugly on the “U” pivot frame, align the release latch with the recliner piston and snap close.

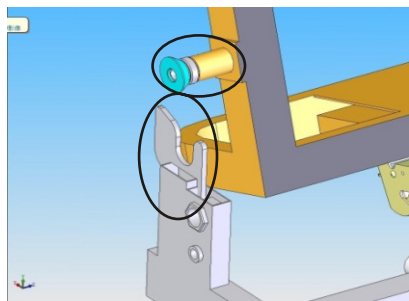

Before operating the chair upon attachment, check following items to ensure proper operation

Figure 1: Shows pivot and “U” pivot frame at correct alignment/ be sure to clear wire

Figure 2: Close-up view of pivot and “U” pivot frame.

Figure 3: Shows correct pivot alignment.

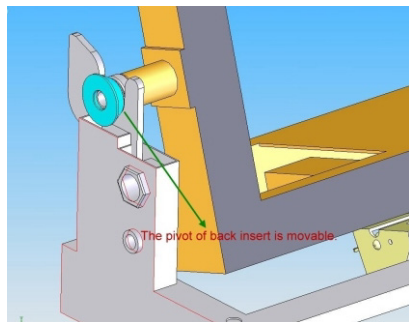



The pivot of back insert is removable

Empress LX/RX: Remote Control Functions

POWER 
On/Off

TIME 
Manual time setting for 10/20/30 min.

RANGE 
To select an area to massage, such as neck, back, waist.

WHEEL ADJUST UP/DOWN 
Massage roller can be up and down to move massage rollers position while you operate with manual and combination.

ELECTRIC/RECLINE 
Press once, the chair will move automatically, press twice to stop the movement.

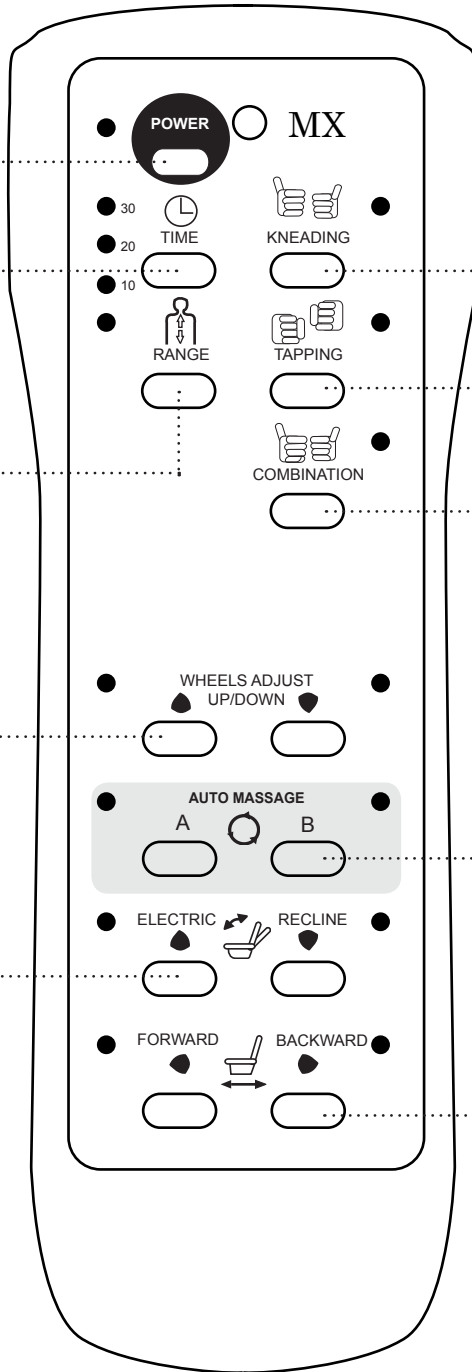

KNEADING 
10/20/30 Min.
It has 3 intensity adjustments for strong/medium/weak. The preset intensity is weak.

TAPPING 
It has strong/medium/weak 3 intensity adjustments and the setting intensity is at medium. (10/20/30 min)

COMBINATION 
Combine kneading and tapping. (10/20/30 min)

AUTO MASSAGE 
Automatic program selection button A/B. Each auto has two programs, press once - the light will shine continuously (general Massage), Press twice - the light will flash (stronger massage).

FORWARD/BACKWARD 
Press once, the chair will move automatically, press twice to stop the movement.

Empress LX/RX: Remote Holder Assembly

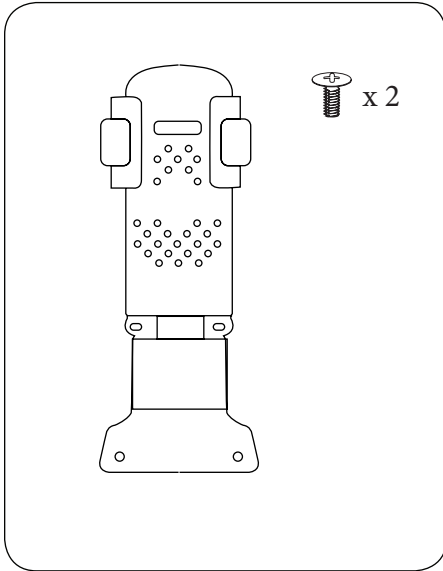

*Content

a) Remote Holder

b) 2 phillip x screws

1.

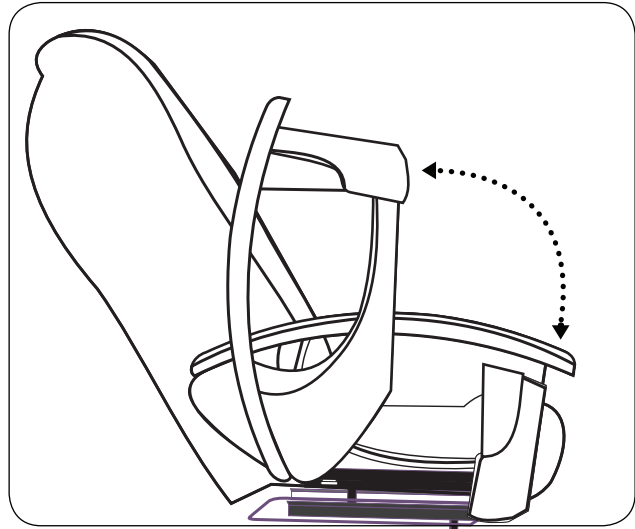

Lift ArmRest (lift from Front)

2.

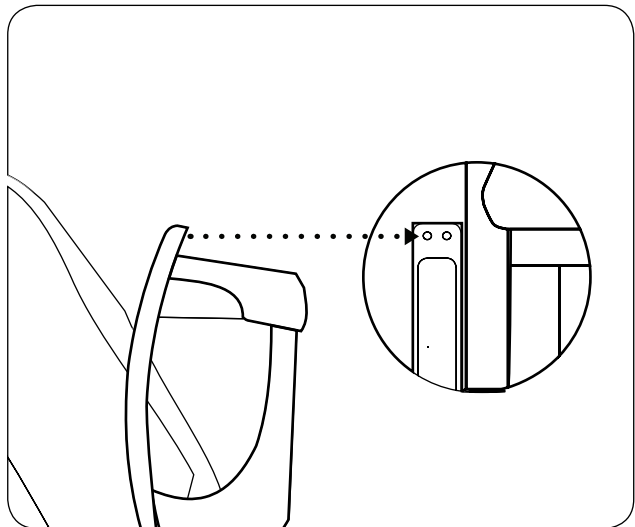

Note of front embedded nut for remote as shown.

3.

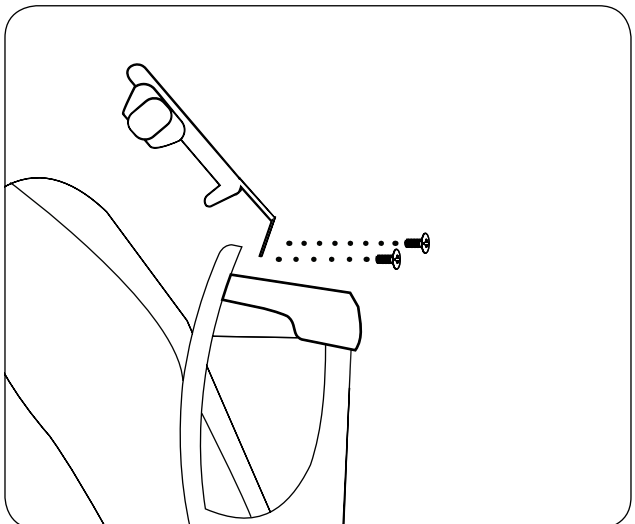

Placed remote holder (as shown) and align with embedded nuts screw in one at a time.

Empress LX/RX: Footrest Assembly

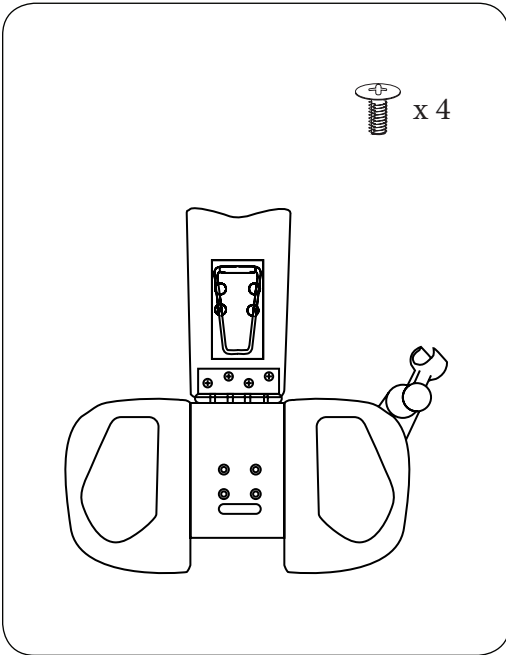

*Content

- a) Pre- Assembled Footrest mechanism & Cushion with shower holder
- b) 2 phillip x screws

1.

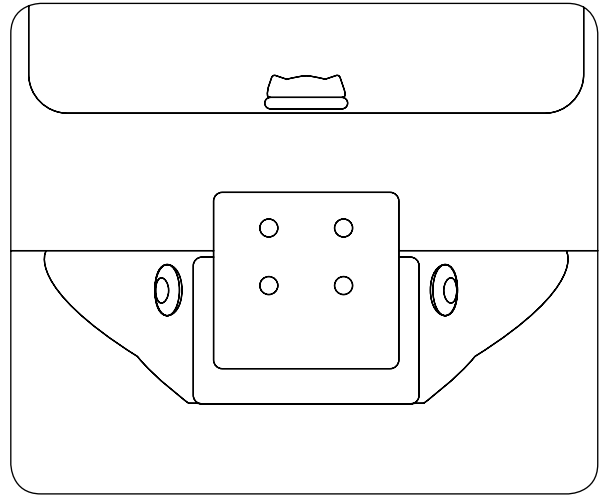

Remove 4 philips screw from FootRest stand.

2.

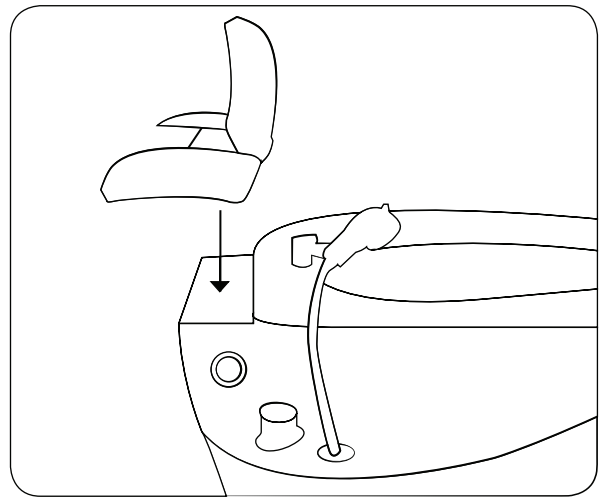

Placed Pre-Assembled on top of Footrest stand: Align 4 holes.

3.

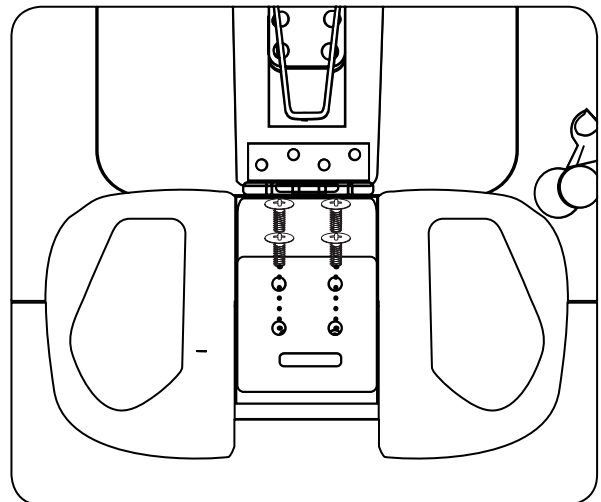

Screw in one at a time(Don't tight) All screws in place

4.

Rotate shower holder(Top should be larger than Bottom)