



# THE ANCORA LIGHT

---

## Technical Specifications



01 - SHADE TYPE



Ancora  
Wicker shade  
ref: w2w







Ancora  
Rattan shade  
ref: w2r





01 - SHADE TYPE



Ancora  
Fabric shade  
ref: w1





Tinted

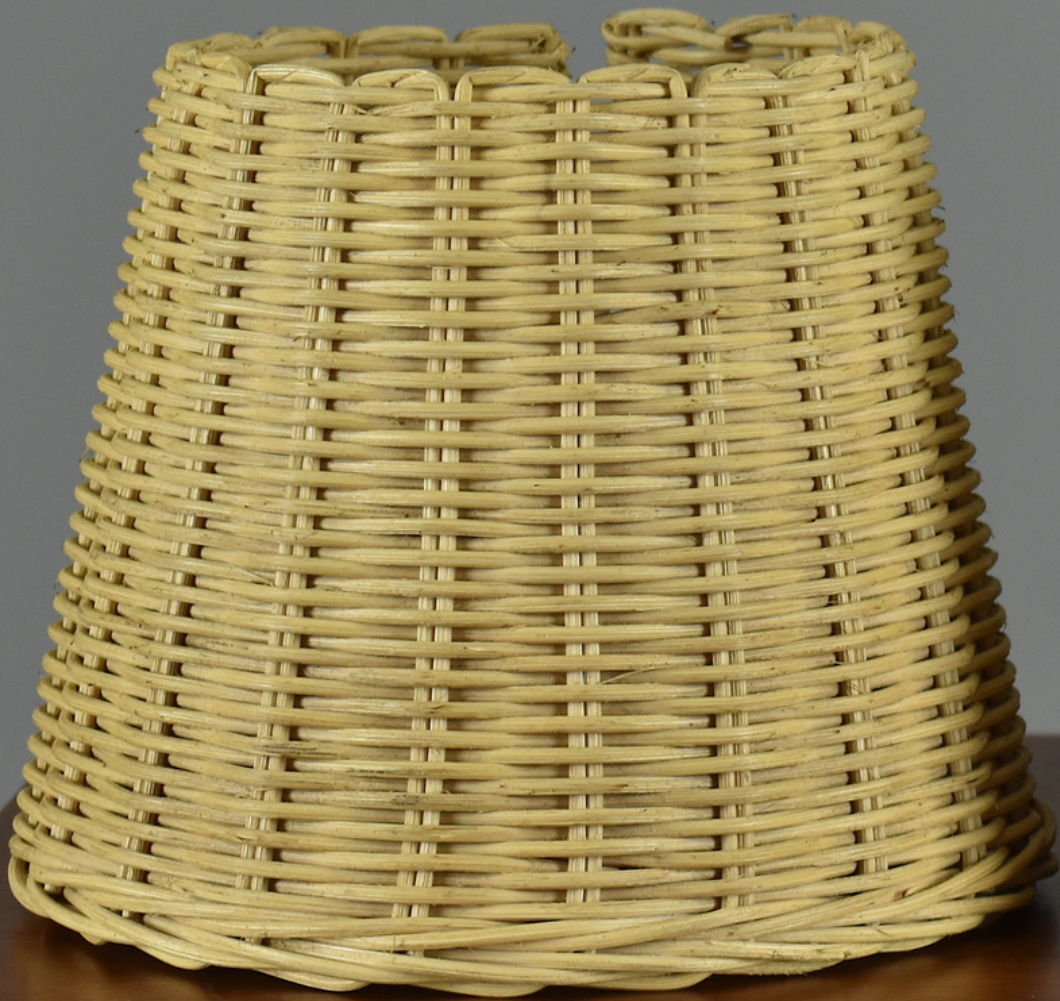

Natural







Please contact us if you're looking for a more personalised leather colour





Polished brass with lacquer



Polished brass no lacquer



Aged brass



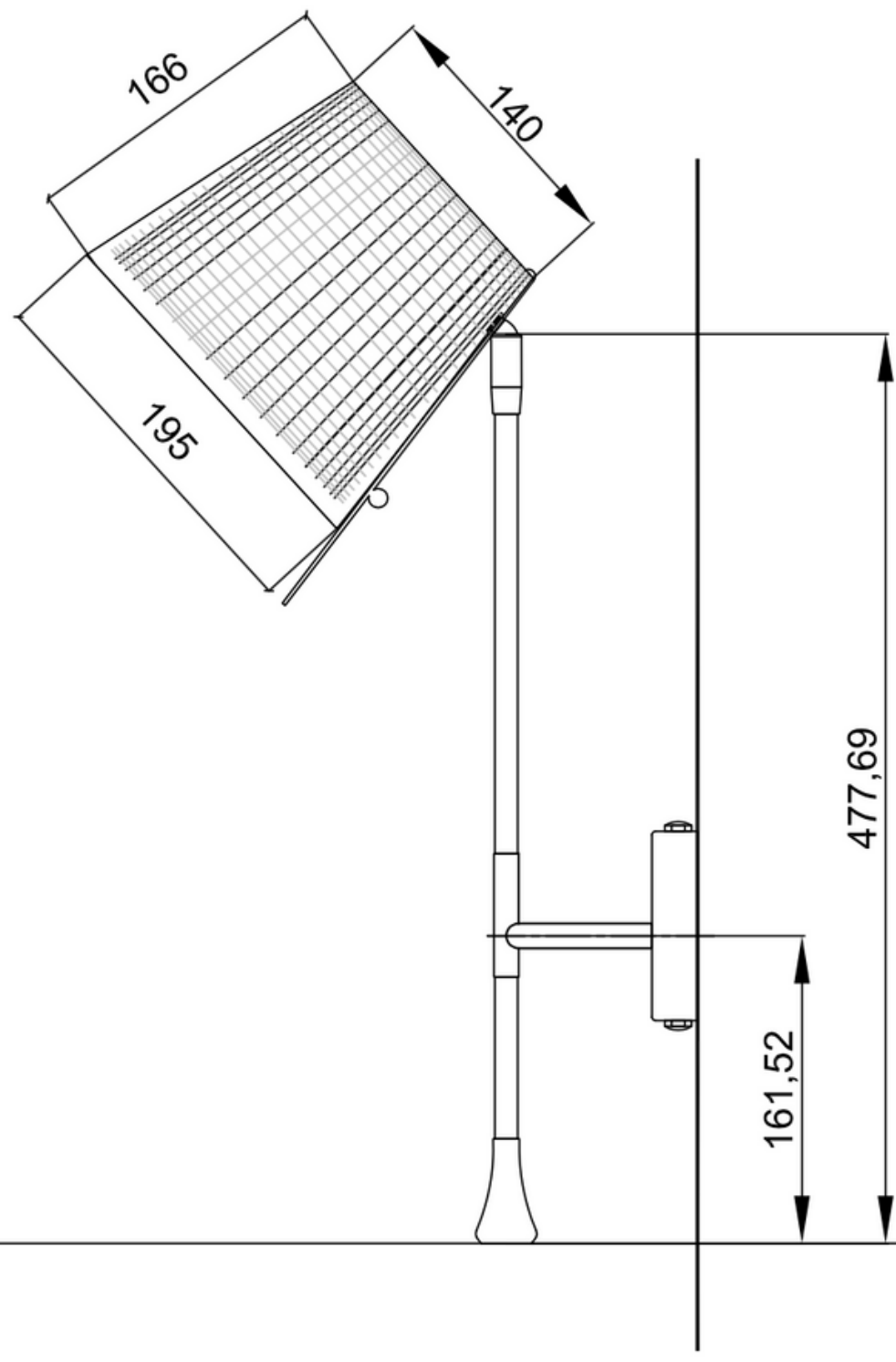
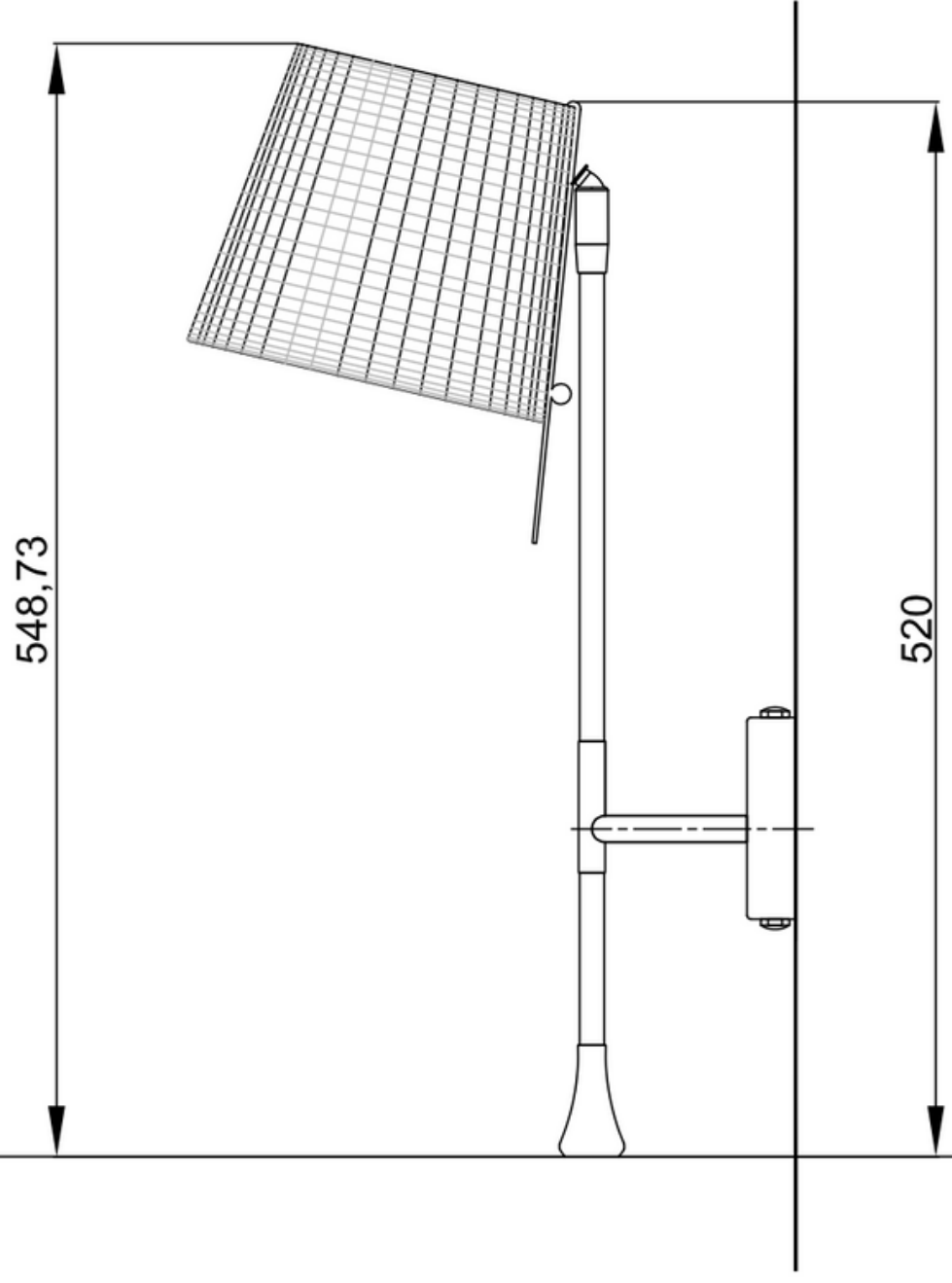



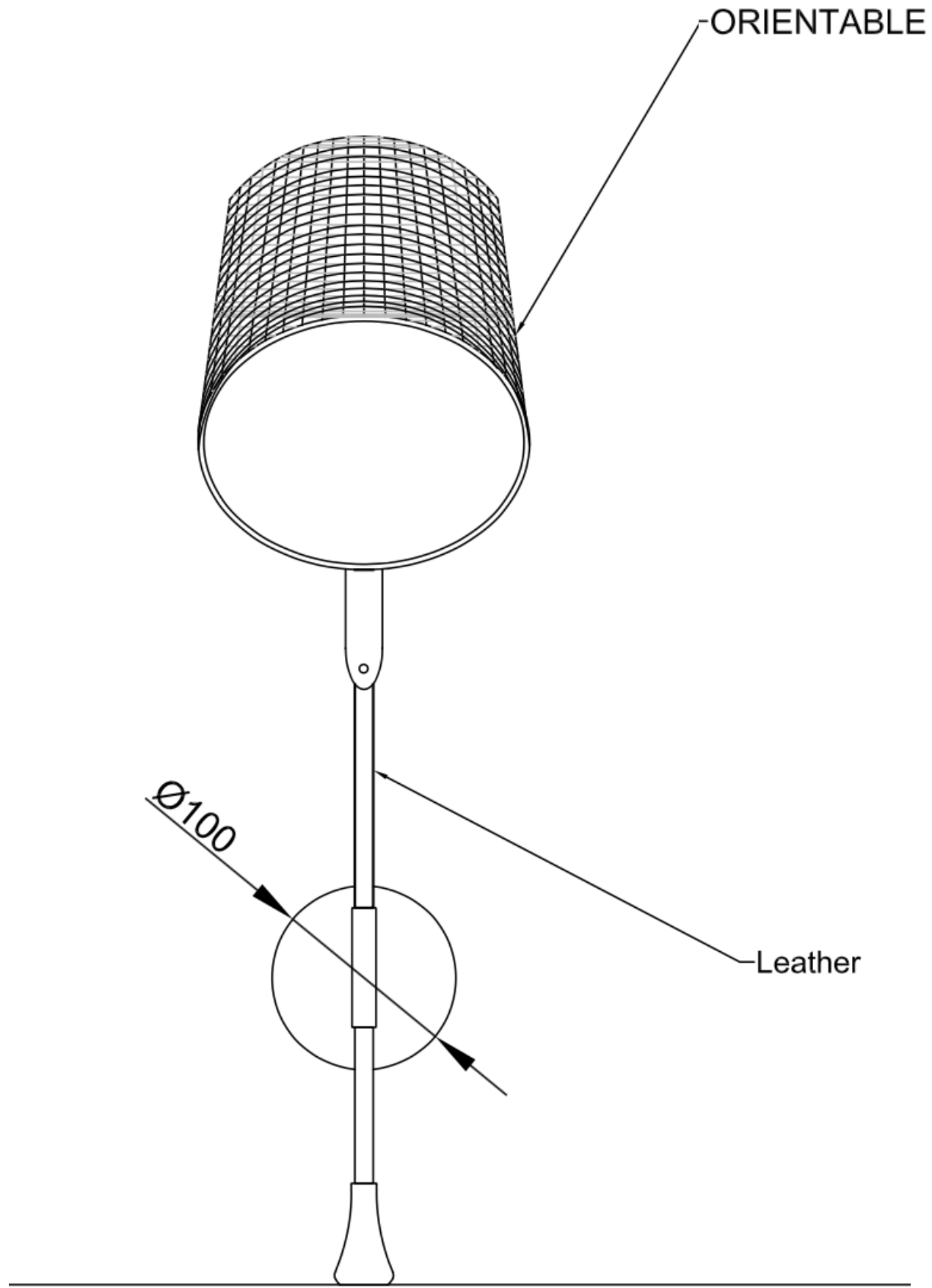



**1** Screw backplate to ceiling and J-box.

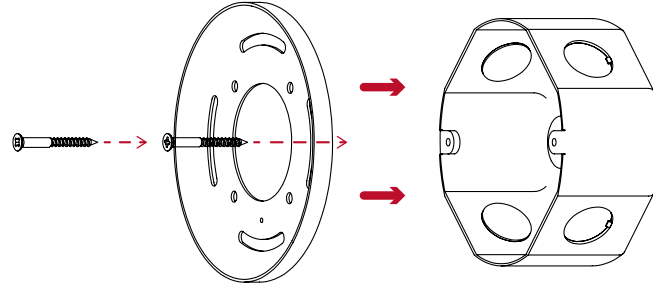

**2** Make the electrical connections, inside canopy

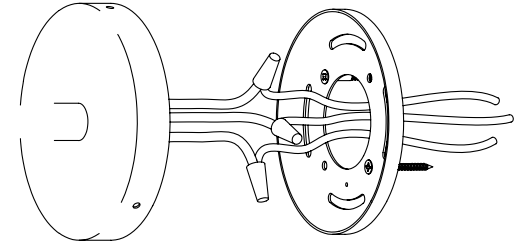

**3** Hide electrical components/connections inside J-box.

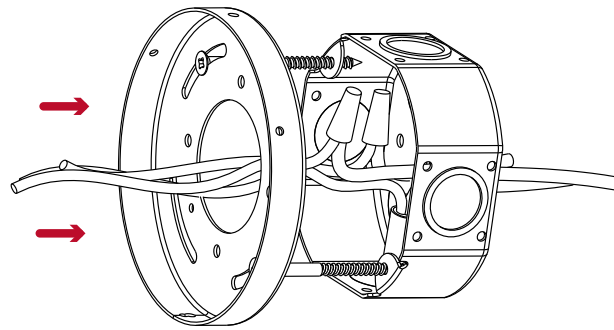

**4** Place canopy in backplate. Fix with screws.

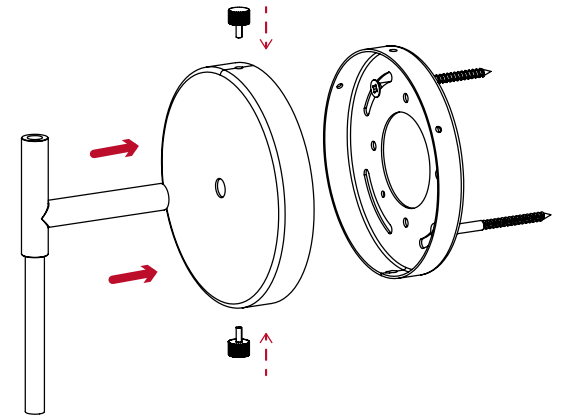

**5** Place shade in metal structure.

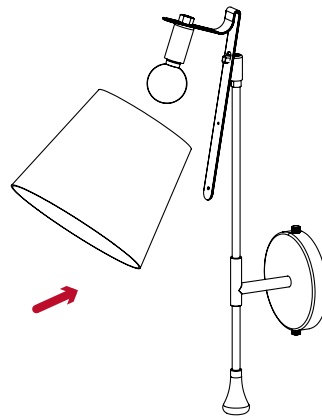

**6** Fix shade with provided nuts.

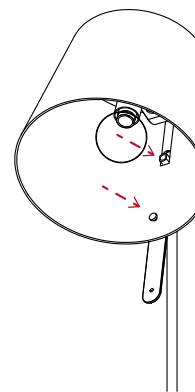

**7**

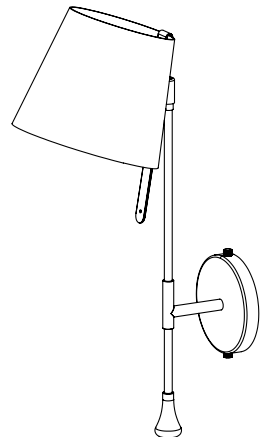

Socket: E26 socket base, MAX. 15W each

Voltage: 120V



**ATTENTION**

Always shut off power before installing and doing any cleaning or maintenance.



All products are manufactured to meet or exceed North American standards C22.2-250, UL 1598, C22.2-12, C22.2.9, UL 153.

All preparation for installation of fixture is to be provided by the end user.

The description and measurements on this drawing are for information purposes only.

JONATHAN AMAR STUDIO, 2023  
All rights reserved.



## **Our Studio**

Since 1989 our studio - JAS - works on prestigious projects internationally for both private and commercial spaces. Our activities are split into three domains: design studio, manufacturing and interior design consultancy.

Since the early 1980's Jonathan has designed or supplied lighting and furniture for more than 150 restaurants, clubs and bars in Paris alone. In the interior design field, he also intervenes on the concept creation and brand design experience. To name a few: Les Bains Douches, Comptoir Marrakech, Renaissance hotel, Castel, Nobu, numerous Costes restaurants and bars in Paris, Momo's and Sketch in London, Aroma Café in Bahrein, Club Med suites, Saint James hotel, Royal Mansour, Ping Pong London.

We also offers consultancy advice for international design firms with luxury projects in Morocco by overseeing artisanal production units.

Our studio designs and produces bespoke brass lighting, furniture and accessories with a style characterised by the double ambition of being modern and familiar, universal yet poetic. Each product embraces a contemporary outlook on our rich Moroccan heritage.

Our lighting collections are mainly handcrafted in Leiria, a small city in Portugal reputed for its exquisite glass making, and Rabat Morocco.

Our know-how stems from combining traditional materials such as wicker, rattan and leather with brass using meticulous workmanship.

Our bespoke collections represent 35 years of passion and know-how in the fields of decorative arts and interior design.

Over these years we have built a strong ecosystem within Moroccan artisanry, with the aim of perpetuating our cultural heritage.

Each product design is customisable and therefore adapted to all types of clients or professionals for small and big scale projects. All items are also made-to-measure and available upon order.

## **Craftsmanship**

Handcrafted between France, Portugal and Morocco with exclusive French and Italian resources, our pieces honour the relationship between meticulous workmanship and quality materials through the thickness, finishes and fixtures of each creation.

Due to the handmade nature each piece is unique and might vary slightly in finish.

## **Materials**

Brass and glass, the central element of most creations, are available in an array of finishes.

The finish you select and the way you care for your purchase throughout the years results in one-of-a-kind pieces. Since Brass is a metal that works well with a multitude of materials, our studio associates it with a unique palette of colors and textures.

Fabric and wicker are used to design lampshades; mosaics and marbles form table tops and bases; lamp stems are sheathed in hand-pleated leather by artisan saddlers. Hand-engraving and brass openwork, the core know-how of our studio, bring forth a new perspective on each design.

## **Practical Lights**

- Built with a sophisticated pear-shaped joint (patented design), extendible arms, and functional handles.
- Equipped with optional latest led sensory dimming or wireless technologies.
- Available in a variety of sizes to cover all types of living areas.



# Contact Us

[info@spiritgallery.fr](mailto:info@spiritgallery.fr)

[www.spiritgallery.fr](http://www.spiritgallery.fr)  
[www.jonathanamar.net](http://www.jonathanamar.net)

+212 5 37 80 66 33

+ 212 6 61 41 45 00

## **Morocco**

24, Zone Industrielle Azzahra,  
Oulja 11000 Salé  
Morocco

## **France**

36, rue Lebour  
92100, Montreuil  
France