



SPHERE

QUICK START GUIDE



Welcome

Thanks for purchasing the Synexis Sphere.
After opening the box, unpack and inspect
your device and bulb for damage.

First use

DO NOT OPERATE THIS DEVICE IF ANY DAMAGE IS NOTED. If the device is damaged,
contact your Synexis Account Representative at (844) 352-7680.

Getting to know your device

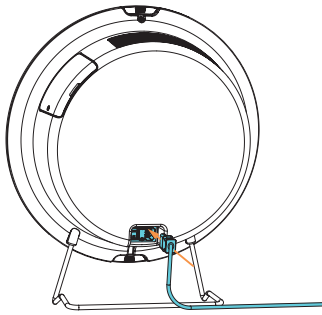

1 On/Off switch and plug

- located on back side of the device
- plug power cable into back
- green indicator will illuminate when power is on

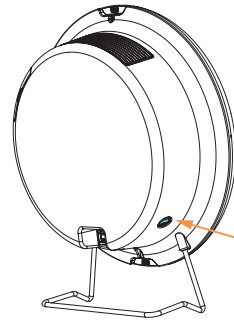

2

Fan speed control switch

Removing cover

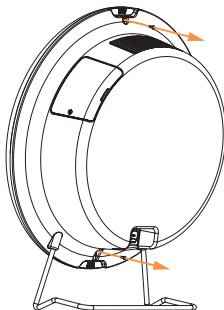

1

Remove safety screws, top and bottom

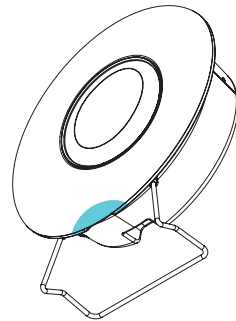

2

Hold the bottom of the device

Included parts:

- 1 set of filters (1 carbon filter, 1 MERV 11 filter)
- 1 UV-A bulb
- 1 power cord
- 1 stand (already installed) or wall mount bracket
- 1 Torx T10 T-Handle screwdriver (for Locking Screw)
- 1 Security Torx T10 "L" Shaped tool (for Bulb Cover)

When should I replace the following components?

- carbon filter: approx. 6 months
- MERV filter: approx. 3 months
- Sail: approx. 3 months
- bulb: approx. 2 years

Visit Synexis.com/manuals for detailed product information and wall mounting installation instructions.

Removing cover (cont.)

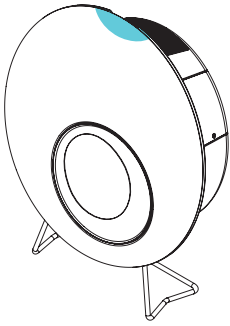

3 Grab the recess on top

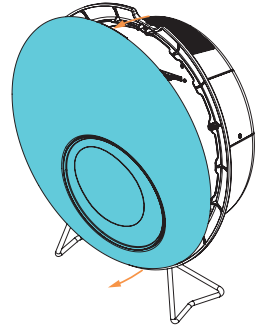

4 Pull the top and bottom of the cover to disengage the magnets

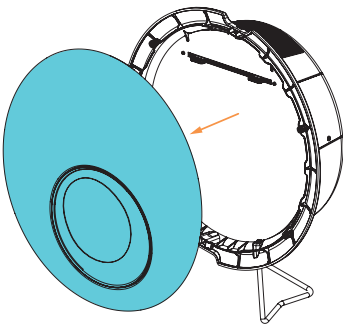

5 Remove the cover

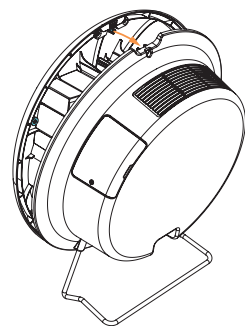

6 Putting the cover back on

- position top and bottom pins over slots
- let magnets reengage
- fasten safety screws

Inserting Sail

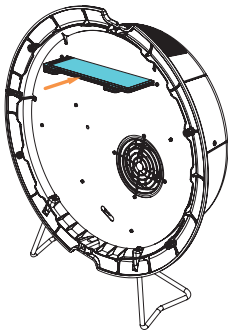

1

Insert the new Sail
(Sail ships separately)

Replacing Sail

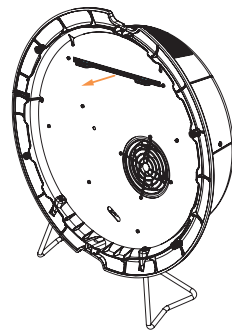

1

Hold tabs of the Sail
and pull toward you

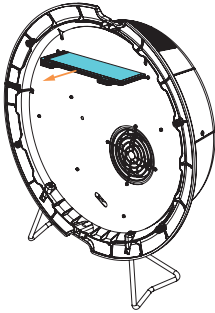

2

Remove and insert the new Sail

Replacing the filters

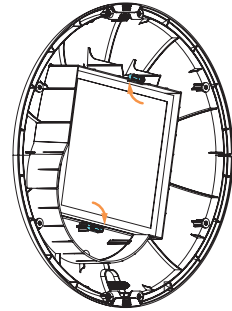

1

Turn the tabs 90°

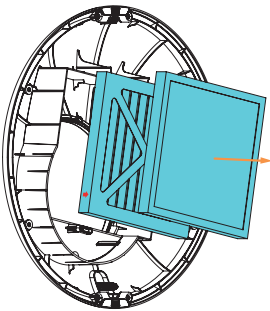

2

Remove the filters

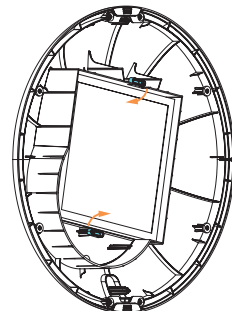

3

Insert new filters and turn tabs to secure

- airflow arrow on MERV 11 filter points toward unit
- carbon filter on top of MERV 11 filter

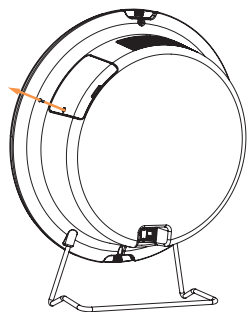

1 Remove safety screw

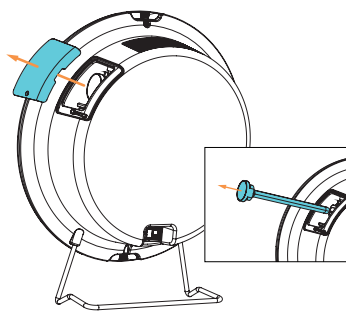

2 Remove bulb cover
(and bulb if already inserted)

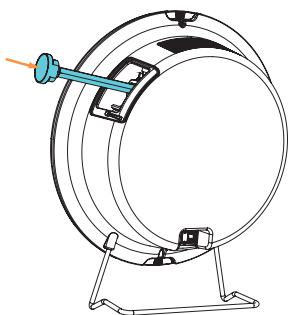

3 Insert new bulb
- align the 4 pins to the female
socket connectors

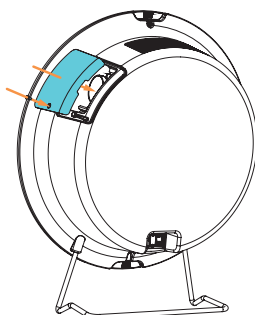

4 Replace bulb cover and fasten the screw

