

## IDS Aviation Architecture Components Diagram

AVMS Software Component Diagram

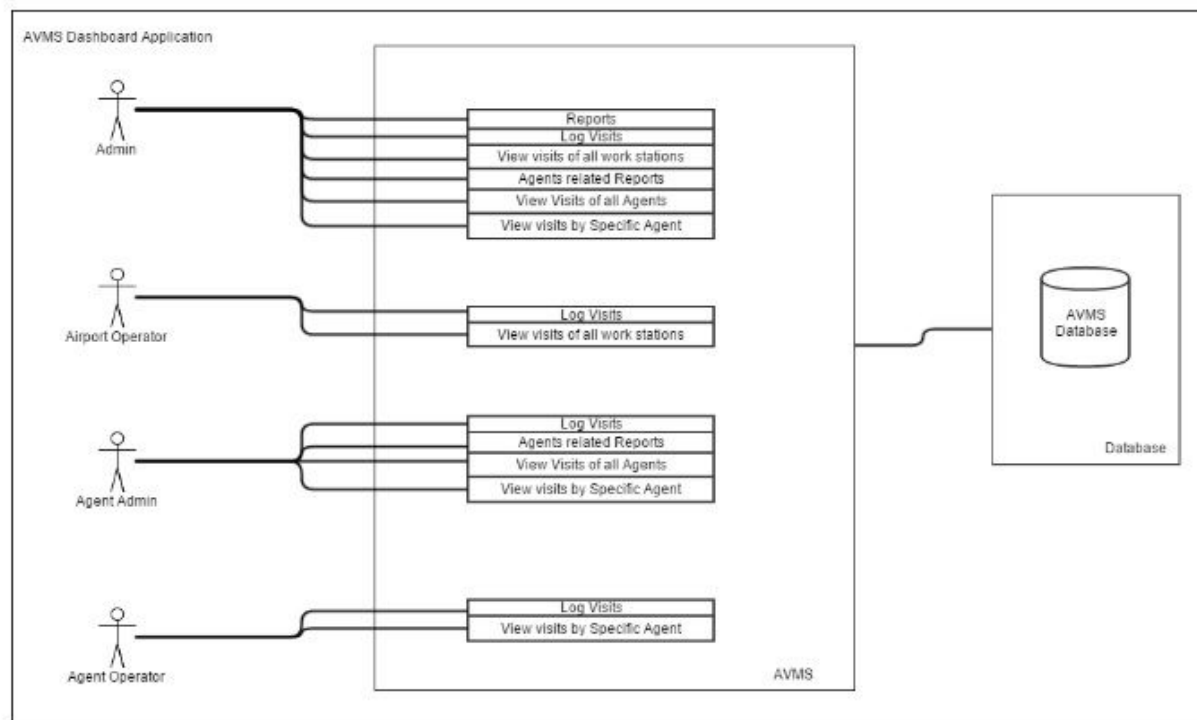

# Aviation Visitor Management System High-Level Layer Architecture Diagram

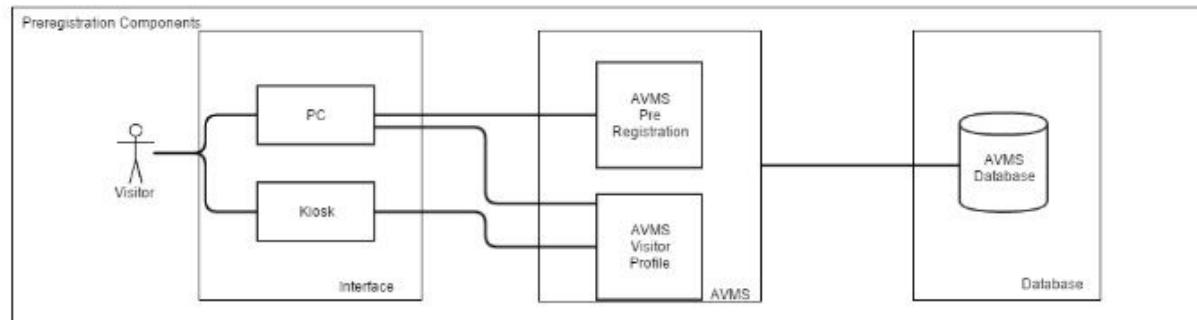
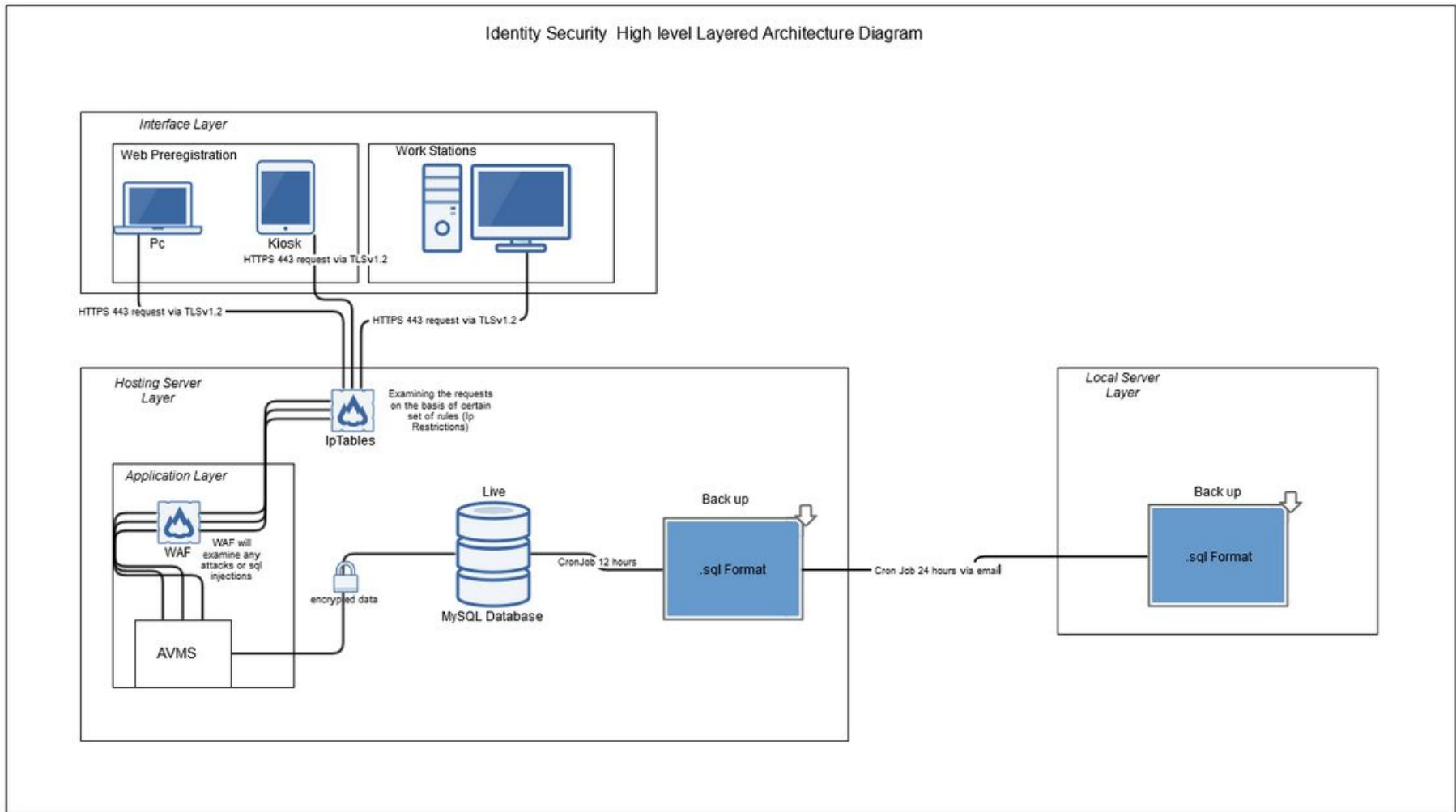

1. IP Tables are configured on the hosting server.
2. After the request proceeds from IP Tables, the request will go through WAF (Web Application Firewall) to protect from different kinds of attack eg. DoS or SQL injections.
3. The data will be encrypted and will be saved in the database.
4. The backup will be automatically generated after 12 hours on the server
5. For disaster management every day the data backup will be automatically sent to the local server