

HOROTEC[®]
SWISS

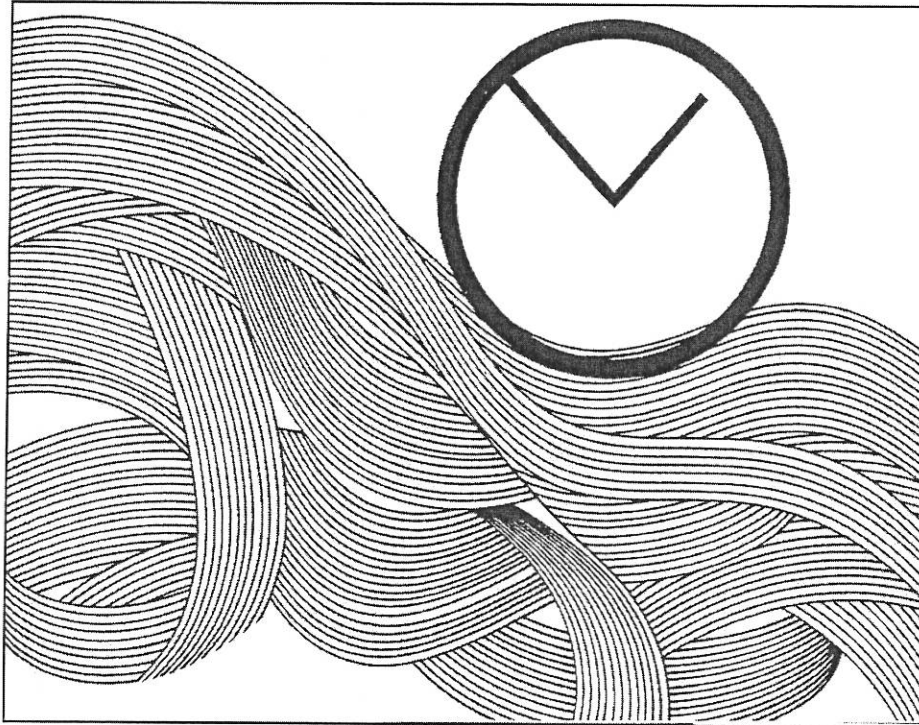

*Quality
Swiss Made Tools*

PERRIN
H & W PERRIN

90 Thorncliffe Park Drive
Toronto ON M4H 1N5
E-MAIL Address:
sales@perrin.on.ca

Phone
(416) 422-4600
Toll Free: 1-800-387-5117

Fax
(416) 422-0290
Toll Free: 1-800-741-6139

Horotec Catalogue 2009

SELF-ADHESIVE POLYIMIDE RIBBON FOR BRACELET POLISHING

Tough polyimide tape is ideal for watch bracelet refinishing. When bracelets have two-tone finishes and they need polishing, you can use this tape to cover the area you do not want to re-finish. Comes in various diameters for all types of bracelet repair. Each roll is approx. 33 meters in length.

Width	Order number
2mm	67.70007-02
3mm	67.70007-03
4mm	67.70007-04
5mm	67.70007-05
7mm	67.70007-07
9mm	67.70007-09

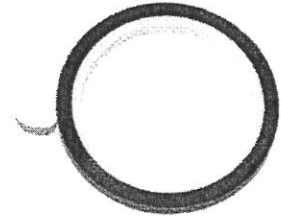

"GARRYFLEX" RUBBERIZED ABRASIVE BLOCKS.

3" x 1 7/8" x 3/4" rubber block impregnated with a gentle abrasive. Use for polishing, cleaning, or texturing on iron, aluminum, ceramics, paintwork etc. These rubberized blocks can be used wet or dry. Available in 3 grits

67.26298-36	Grit 36 very coarse - burgundy colour
67.26298-60	Grit 60 coarse - blue colour
67.26298-240	Grit 240 fine - brown colour

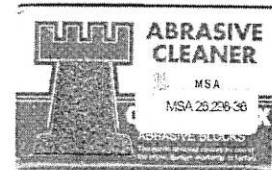

SATIN FINISHING BLOCKS.

Impregnated rubber blocks for satin finishing watch cases, watch bracelets etc. These abrasive blocks can be used in dry or wet applications, with water, solvents or detergents. Ideal for texturing or removing scratches.

Available in 4 grits:

67.26297-30	Grit 30 very coarse
67.26297-60	Grit 60 coarse
67.26297-120	Grit 120 medium
67.26297-240	Grit 240 fine.



67.23500 UNI-POLISH

This is a special chuck with a uniquely designed chuck for securely holding watch cases, and watch case backs when polishing. Opens from 14 to 34mm.

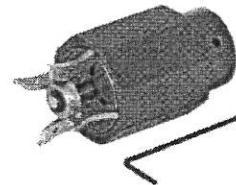

LOCTITE ADHESIVES

LOCTITE "350" ULTRAVIOLET GLUE # 67.26535

Loctite 350 is a medium viscosity adhesive that forms tough, flexible bonds with excellent adhesion to glass and metals. Strength retention is excellent when exposed to water or humidity. The product has a long open working time, making it ideal for fitting mineral or sapphire crystals. Cure rate and depth of cure will depend upon light intensity, light source. Cures crystal clear. 50ml bottle. Not recommended for gluing plastic crystals.



LOCTITE "222" THREAD ADHESIVE # 67.26520

Loctite 222 is designed for locking and sealing of threaded fasteners which require easy disassembly. The product cures when confined in the absence of air between close fitting metal surfaces and prevents loosening and leakage from shock and vibration. Particularly suitable for applications such as adjustment of set screws, small diameter threads or long engagement length fasteners where easy disassembly is required without shearing the thread. Resists migration after application (Strength: low) 10ml bottle.



LOCTITE "243" THREAD ADHESIVE # 67.26522

Loctite 243 is designed for locking and sealing of threaded fasteners which require normal disassembly with standard hand tools. This adhesive operates the same as Loctite 222, but has a higher hold strength. Particularly suitable for less substrates such as stainless steel and plated surfaces. Resists migration after application. (Strength medium) 10ml bottle



LOCTITE "290" THREAD ADHESIVE # 67.26526

Loctite 290 is designed for locking and sealing fasteners. Because of its low viscosity and capillary action, the product wicks between threads and eliminates the need for disassembly prior to application. The product can also fill porosity in welds, castings and powder metal parts (Strength medium to high) 10ml bottle.



LOCTITE "401" INSTANT ADHESIVE # 67.26533

Loctite 401 is a fast setting cyanoacrylate adhesive designed for the assembly of difficult to bond materials which require uniform stress distribution and strong tension and/or shear strength. The product provides rapid bonding of a wide range of materials including metals, plastics, and elastomers. Particularly suited for bonding porous or absorbent materials such as wood, paper, leather and fabrics. Appearance (uncured) is transparent, colourless to straw coloured liquid. 20 gram bottle.



LOCTITE "480" INSTANT ADHESIVE # 67.26519

Loctite 480 is a fast setting cyanoacrylate adhesive. It is a low viscosity adhesive which will bond metals, plastics and rubbers. This is a rubber toughened adhesive with increased flexibility and peel strength along with enhanced resistance to shock. The curing process is initiated by the atmospheric moisture in the air. The rate of cure will depend on the bonding gap. A thin bond gap will cure faster than a wide bond gap. Appearance (uncured) black liquid. 20 gram bottle



LOCTITE "601" RETAINING ADHESIVE # 67.26543

Loctite 601 is designed for the bonding cylindrical fitting parts, particularly where low viscosity is required. The product cures when confined in the absence of air between close fitting metal surfaces and prevents loosening and leakage from shock and vibration. Appearance (uncured) is a green liquid. (Strength high) 10ml bottle



MICRO STELLA TOOL # 67.3670

This tool is for setting the balance wheel screws for Rolex calibers 1530 & derivatives, Rolex calibers 2130 & derivatives, Rolex calibers 3035, 3135 etc. Tools features a graduated scale, each division represents 1 second per day on the low head screws and 2 seconds per day on the high head screws. A must for anyone doing Rolex repairs.

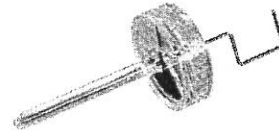

OMEGA CO-AXIAL ADJUSTMENT KEY # 67.3671

For correcting the movement rate of the co-axial movement Omega 2500. Operates basically the same as the Rolex Micro Stella Tools, but this tool has square holes to fit the balance adjustment screws of the Omega caliber 2500.

Horotec adjustment key

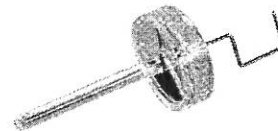

UNIVERSAL BATTERY TESTER #67.19000

Tests mercury, silver oxide, 3V lithium batteries. Designed to test AA, C, D, N, AAA & ni-cads, 9V, 12V 15V, 22.5V batteries. To test watch batteries simply pop the cell into a slot on the side of tester and press button. For larger batteries there are positive and negative contacts on top of the tester as well as positive and negative wire leads. Dimension of the tester 100 x 74 x 33mm. Very effective, cost efficient battery tester.

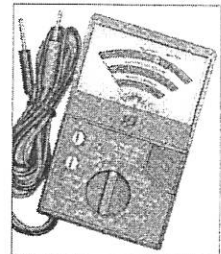

SEIKO DIGITAL BATTERY TESTER #67.19002

Compact pocket sized cell tester. Use with probe wires. Gives an exact voltage reading on the easy to read digital display. Tester with vinyl folder measures 3" x 4 3/4" x 5/8". Fits nicely into a pocket, designed for those that need a tester "on the go".

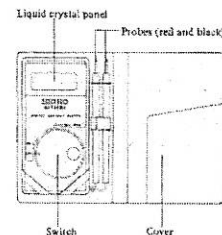

RENATA BATTERY TESTER # 67,19004

This battery tester is designed by Renata to test Renata batteries. Tester looks like a watch battery. a built in impulse detector. This impulse detector amplifies the impulse of the circuit and coil. If you change a battery, and the watch is not working, by placing the watch on the impulse detector, you can verify if a problem exists on the mechanical side of the watch (impulses but hands do not move) or on the quartz side of the watch (new battery - no impulse). This gives you the ability to inform your customer about the severity of the problems with his/her watch. Has a built in automatic shutoff. Allows you to test all watch batteries including 1.55 volt silver oxide batteries and 3 volt lithium batteries. In addition it has

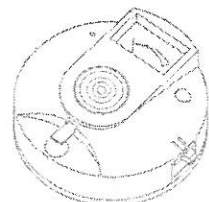

BATTERY, PULSE & COIL TESTER # 67.19105

Designed to test silver oxide batteries both low and high drain, as well as lithium batteries. Tests for "pulse" output of the movement. Test for coil "continuity" using detachable leads. A helpful instrument in determining where the problem lies in a quartz watch. Unit measures 150mm x 83mm x 55mm.



RIDGED BENCH PLATES

Grey vinyl bench plates with heavy ridging. When installed at the back or to one side of your bench, this plate becomes an excellent place for many hand tools that live on the bench. The ridging eliminates the tendency for tools to roll away or clumped into piles. Plate features a self-adhesive backing.

Two sizes available: #67.24220 - size 10cm x 15cm
#67.24221 - size 18cm x 30cm

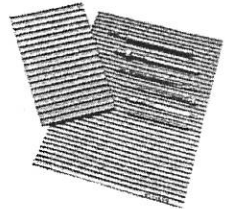

SELF ADHESIVE BENCH STRIP # 67.24211

Clear vinyl strip which is mounted on the face or top edge of the watchmakers bench. Watches can be wound by simply running the crown along this strip. Also ideal for setting the date on watches which do not have fast set on the calendar function. Supplied with a self-adhesive backing



HOROTEC STACKABLE WATCH REPAIR TRAYS

Stackable watch repair trays with lockable lids. These trays measure 237 x 105mm (9 3/8" x 4 1/8"). They are available with 10 square compartments or with 5 square and 1 long compartment for watch with bracelet attached. These shop trays each have 2 raised posts which fit into the tray above. This allows many trays to be stacked securely. Available separately are clear lids, which can be placed on the top tray. Available in various colours allowing you to colour code for types of jobs, urgency required etc.

Soft foam tray inserts can be purchased separately to protect gold watch cases and other important items from scratching.

Colour	10 compartment	6 compartment
Blue	67.17530B	67.17527B
Yellow	67.17530J	67.17527J
Red	67.17530R	67.17527R
Green	67.17530V	67.17527V

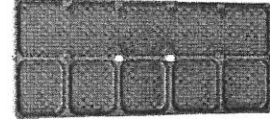
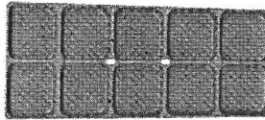

Clear lids only	67.17528	
Plastic locking keys	67.17531-1	black 1 lid, 1 tray
	67.17531-2	yellow 1 lid, 2 trays
	67.17531-3	red 1 lid, 3 trays
	67.17531-4	green 1 lid, 4 trays
	67.17531-5	blue 1 lid, 5 trays

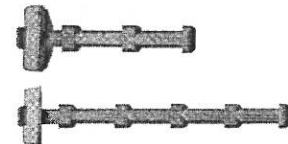
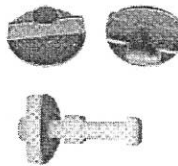

Small foam insert	67.17532	(49 x 45 x 16mm)
Large foam insert	67.17532A	(234 x 42 x 16mm).

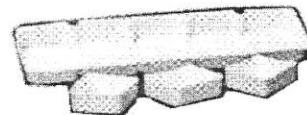

BRACELET PIN PLIER

This plier is identical to numbers 66.9005 & 66.9006. This economical version is supplied in a box with a total of 5 plungers with the dimensions of 0.60, 1.00, 1.20, 1.50mm. Pins are not supplied separately, only complete replacement plungers available. The one advantage of this particular plier is the additional large diameters of plunger for the heavier divers type watch bracelets.

- complete plier #67.10006
- replacement plunger 0.60mm #67.10004-060
- replacement plunger 0.80mm #67.10004-080
- replacement plunger 1.00mm #67.10004-100
- replacement plunger 1.20mm #67.10004-120
- replacement plunger 1.50mm #67.10004-150

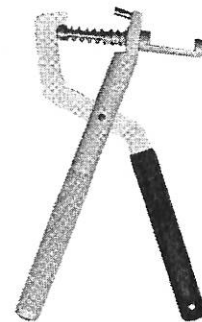

#67.10500 - HOROTEC BRACELET PRESS.

Horotec has designed a bracelet press similar to the Bergeon press, a little less sophisticated. Very functional, easy to use, good quality, popular, and alternatively priced Bracelet press.

This press is designed to

- 1) drive in and drive out friction type metal watch bracelet pins.
- 2) unscrew and screw-in metal watch band bracelet screws, or end piece screws
- 3) unscrew and screw-in "Gucci" style leather band screws.

The press itself is constructed of steel and aluminum. Included with the press are 6 different size pins from 0.60mm through to 2.00mm, pin holder, slotted plastic block, screwdriver with 9 rapid change blades and nylon protector for removing lugs. The press is designed so that all the accessories fit directly on the press, keeping it compact and well organized.

Complete kit 67.10500

Pin holder 67.10500-A

Gasket only for Pin Holder 67.10500-B

Lower support for plastic bracelet block 67.10500-C

Ball bearing for pin holder, and screwdriver handle 67.105000-D

Slotted plastic block 67.10501

Screwdriver blade 0.80mm 67.10502-080

Screwdriver blade 1.00mm 67.10502-100

Screwdriver blade 1.20mm 67.10502-120

Screwdriver blade 1.40mm 67.10502-140

Screwdriver blade 1.60mm 67.10502-160

Screwdriver blade 2.50mm 67.10502-250

Screwdriver handle only 67.10504

Lower stake for screwdriver bits 67.10505

Replacement pin 0.40mm 67.10503-040

Replacement pin 0.60mm 67.10503-060

Replacement pin 0.70mm 67.10503-070

Replacement pin 0.80mm 67.10503-080

Replacement pin 0.90mm 67.10503-090

Replacement pin 1.00mm 67.10503-100

Replacement pin 1.10mm 67.10503-110

Replacement pin 1.20mm 67.10503-120

Replacement pin 1.40mm 67.10503-140

Replacement pin 1.50mm 67.10503-150

Replacement pin 2.00mm 67.10503-200

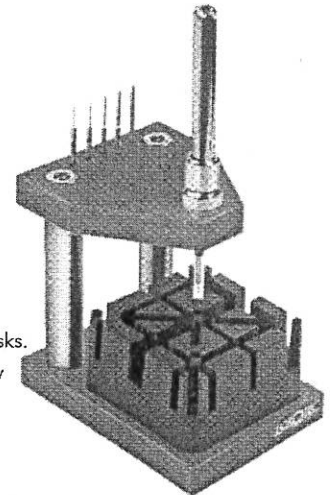
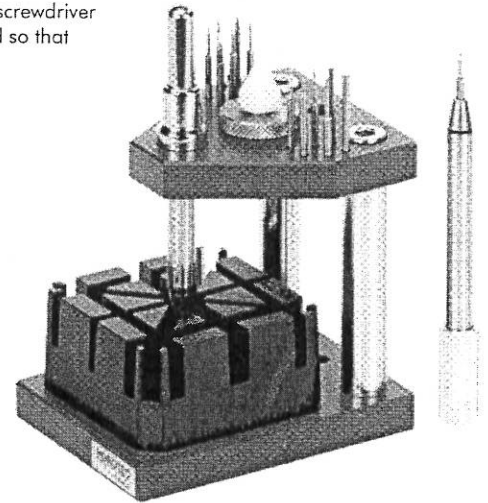

#67.10499 - HOROTEC BRACELET PRESS - REDUCED VERSION

This is the same great press as the 67.10500 without the screwdrivers. Strictly designed for removing friction type bracelet pins. Designed for those looking for a quality tool at an affordable price.

Complete tool 67.10499

All spare parts are identical to those listed for the Horotec Press 67.10500. 67.10513 PLASTIC MINI VISE

Small palm size vise for clamping bracelets or cases on edge. A useful tool for a surprising number of tasks.

Body is made of a tough space age plastic. Block dimension L40mm x W35mm x H23mm. Maximum jaw opening is 10mm. Relief slots below jaw opening to allow travel of pins when used for removing pins from bracelets.

CUTTING BROACH ASSORTMENTS

#67.2155 - Set of 12 cutting broaches from 0.05mm to 0.55mm - Horotec Quality

#67.2161 - Set of 6 cutting broaches 1.46mm to 6.70mm - Horotec Quality

#67.2162 - Set of 4 cutting broaches 7.00 to 10.00mm - Horotec Quality.

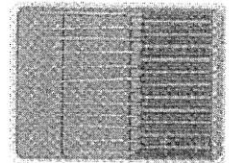

WATCH HAND BROACHING TOOLS

This specialized jig holds watch hands to allow you to enlarge the hole size of the watch hand in question. Put the watch hand between the disks with holes, align the hole of the watch hand with the hole of the broaching tool, then tighten. This allows you to hold the hand while using a cutting broach to increase the hole size without bending or breaking the watch hand.

#67.5001 - 10 holes - HOROTEC QUALITY -

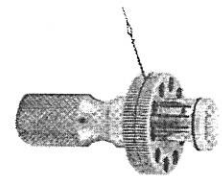

67.26114 MICRO FIBER CLOTH

These soft lint free micro-fiber cloths are perfect for wiping fingerprints from showcase items or watches and watch crystals. A perfect alternative to the Selvyt cloth. Edges are serged and the cloth will retain it's softness even after repeated washes.

Cloth measures 12" x 12" (30cm x 30cm)

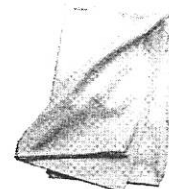

CHAMOIS POLISHING CLOTH

Available in two sizes.

#67.26108 40 x 40 cm

#67.26109 15 x 15 cm



67.7114 HOROTEC OPENER FOR SNAP BACK WATCH CASES

The tool provides a stable platform for the watch and controls the amount of pressure that is placed on the knife blade. When everything is in place, all you have to do is press down on the lever and the case back is levered safely open. There is no risk of following through with the blade and scratching the case or gouging the movement inside. The adjusting knob allows the user to adjust the tool to suit the size of the case and the lever with the blade mounted can be quickly set for height.

Blade is double sided - dimensions 16cm x 6cm x 9cm

Simple to use. This tool eliminates much of the risks involved in prying open case backs.

Complete tool #67.7114

Spare blade #67.7114A

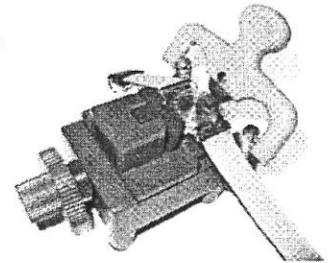

#67.7115 HOROTEC OPENER FOR SNAP BACK WATCH CASES

The final solution for those impossible to open snap back cases. This tool uses mechanical advantage to drive chisel tips into even the slimmest of cracks, and pop off even the tightest fitting case back. It does this in a very precise and controlled manner, without the scratches and gouges caused by using a case knife on this type of problem case. This tool can also be used to remove rotating bezels from watches.

Complete tool # 67.7115

Replacement blade 2.0mm 67.7115A

Replacement blade 4.0mm 67.7115B

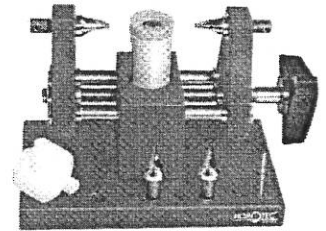

#67.7004 HOROTEC PNEUMATIC CASE OPENER

Supplied with 3 interchangeable tips. When the spring loaded handle is pushed down, energy is accumulated until it reaches the set release point. Then it delivers a stroke with a short-sharp-shock to the tip of the tool. This method will pop off even the most stubborn snap on case backs. The amount of force delivered to the tip is easily adjustable.

Complete tool 67.7004

Set of 3 replacement blades 67.7004-B

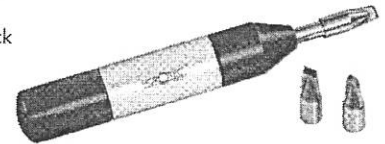

#67.7022 FRICTION BALL FOR TURNING THREADED CASE BACKS.

These colourful rubber balls are perfect for unscrewing threaded case backs after you have broken the tight seal with your case wrench or for starting threads when closing the case. The simple round shape fits the hand surprisingly well. The surface texture provides good friction with metal case backs. Bright colours ensure it will never get lost in the clutter on the bench. Diameter: 65mm

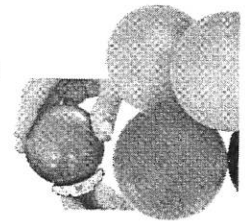

#67.7306 "HOROTEC SWISS" ROLEX STYLE CASE OPENER.

This tool is manufactured by HOROTEC SWISS to open Rolex Watch Cases. This tool consists of a special handle in the shape of a wheel small enough to be held in one hand. This configuration, allows you to apply a downward pressure onto the watch you are trying to open. The set includes 6 quality steel dies to fit Rolex cases.

Complete Tool: 67.7306

Replacement handle (key) 67.7305

Replacement screw 67.7305A

Replacement dies see listing of HOROTEC accessories

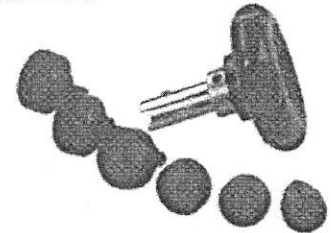

#67.7316 "HOROTEC SWISS" ROLEX STYLE CASE OPENER.

This tool is manufactured by HOROTEC SWISS to open Rolex Watch Cases. This tool features a traditional style handle with a set of 6 quality dies to fit Rolex cases. The dies from all Horotec case opening tools will fit this tool.

Complete tool: 67.7316

Replacement handle: 67.7021

Replacement dies see listing of HOROTEC accessories

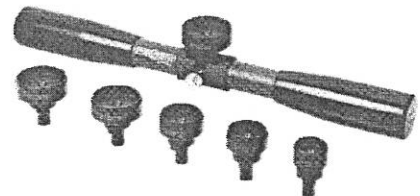

#67.7307 "HOROTEC SWISS" BAUME & MERCIER STYLE CASE OPENER.

This tool is manufactured by HOROTEC SWISS to open Baume & Mercier watch cases. This tool consists of a special handle in the shape of a wheel small enough to be held in one hand. This configuration, allows you to apply a downward pressure onto the watch you are trying to open.

The set includes 3 quality steel dies to fit Baume & Mercier watch cases.

Rolex dies and Baume & Mercier dies are not the same, the knurls on the case backs are different.

Complete tool 67.7307

Replacement handle (key) 67.7305

Replacement screw 67.7305A

Replacement dies see listing of HOROTEC accessories

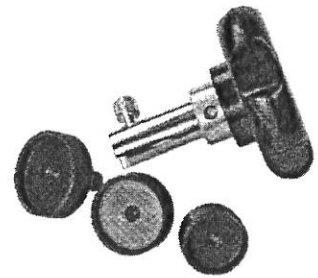

#67.7317 "HOROTEC SWISS" BAUME & MERCIER STYLE CASE OPENER.

Designed to open Baume & Mercier watch cases. This features the standard type handle, versus the wheel type handle.

The advantage with all Horotec case openers, are that all the dies are interchangeable no matter which type of handle you are using. Set includes 3 quality steel dies to fit Baume & Mercier watch cases.

Complete tool 67.7317

Replacement handle 67.7021

Replacement dies see listing of HOROTEC accessories

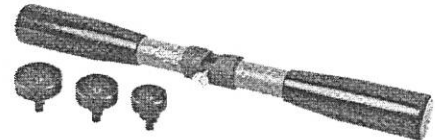

#67.7308 "HOROTEC SWISS" ROLEX AND BAUME & MERCIER STYLE CASE OPENER.

This set is a combination of both sets 67.7308 and 67.7306. Set consists of a special handle in the shape of a wheel and 6 quality steel dies for Rolex watch cases and the 3 quality steel dies for Baume and Mercier watch cases.

Replacement handle (key) 67.7305

Replacement screw 67.7305A

Replacement dies see listing of HOROTEC accessories

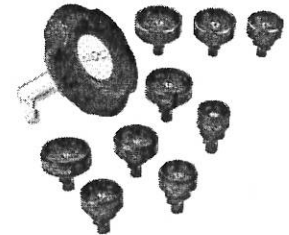

#67.7304 HOROTEC SWISS OMEGA SEAMASTER STYLE CASE OPENER

This tool is manufactured by HOROTEC SWISS to open Omega Seamaster watch cases. This tool consists of a special handle in the shape of a wheel small enough to be held in one hand. This configuration allows you to apply a downward pressure onto the watch you are trying to open.

The set includes 2 quality steel dies to fit Omega Seamaster watch cases.

Complete tool 67.7304

Replacement screw 67.7305A

Replacement dies see listing of HOROTEC accessories

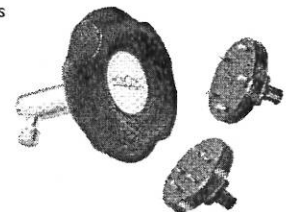

#67.7013 HOROTEC CASE WRENCH FOR OVERSIZE CASES - PARALLEL

Present watch case styles are getting bigger and bigger. This case wrench is designed to open and close a majority of these oversized fashion watches. This wrench has a maximum opening of 53mm. The jaws are designed with extra long tips to allow clearance on heavy cases with predominant lugs. The jaws open parallel with the handle by means of a simple thumb wheel on the handle. Wrench will also accept the tips from Jax and Bergeon case wrenches.

Length 190mm. Tool is supplied with tips 67.7323-E, other tips are available see accessories listed below # 67.7323-A to 67.7323-D

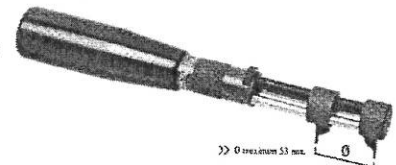

#67.7014 HOROTEC CASE WRENCH FOR OVERSIZE CASES - 90 degree HANDLE

Identical to the wrench 67.7013 with the exception that the handle opens 90 degree to the handle by means of a thumb wheel at the end of the wrench. Wrench will also accept the tips from Jaxa and Bergeon case wrenches. Length 155mm

Tool is supplied with tips 67.7323-E, other tips are available see accessories listed below # 67.7323-A to 67.7323-D

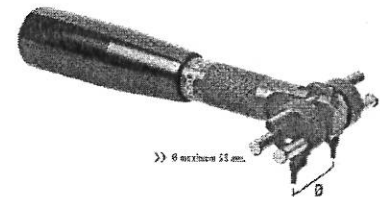

#67.7320 "HOROTEC SWISS" MINI WRENCH CASE OPENER

This specialized wrench is designed for opening and closing screw back watch cases. This particular wrench is supplied with a removeable case vise complete with nylon chucks to avoid marking the watch case. Will adjust for any case. The pin holder is supplied complete with 4 pairs of pins to engage different types of case backs including, round holes, flat edges, square holes and milled or fluted edges (oyster). 4 non-slip pads are mounted on the base or you can bolt this unit permanently to your work bench. This robust case opener is built to last. The compact size of this opener makes it easy to store when not in use. Dimensions 190mm H x 110mm W x 95mm D.

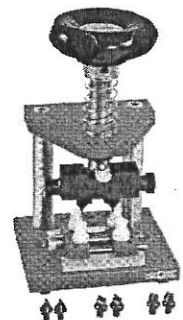

#67.7363 "HOROTEC SWISS" LARGE CASE OPENER.

This is Horotec's top of the line case opening and closing press. Comes complete with every die imaginable to get the job done. Special features include; 1) Ergonomic hand wheel

- large 160mm diameter, to provide you with maximum strength
- 2) Central spindle with a precise blocking ring for adjusting the height.
- 3) Universal fixing system with all the accessories
- 4) Removable case vice with concave pins to centralize quickly the watch cases
- 5) Robust steel supporting pillars with non-skid synthetic holder for right or left-handed persons.
- 6) Base with a removable turning plate to keep your dies organized and within reach.
- 7) 16 dies supplied - 6 for Rolex Cases, - 3 for Baume & Mercier Cases
- 7 suction dies for polished case backs
- 8) 4 pairs of pins for watch cases with round holes - square holes - with sides - or striated sides.

The advantage with this press is its size, the complete selection of dies and pins to open the vast majority of watch cases on the market. The set is supplied complete right from the start, no need to add accessories.

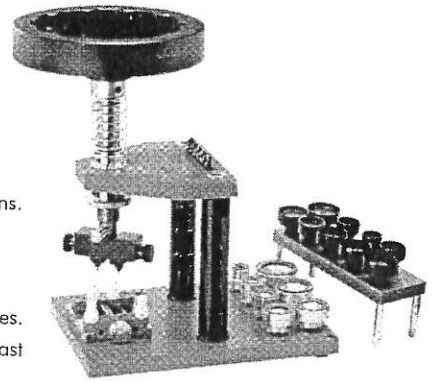

"HOROTEC SWISS" ACCESSORIES, REPLACEMENT PARTS FOR BOTH 67.7363, 67.7320, 67.7306, 67.7307 and others.

The advantage with the Horotec system of presses, is that the attachments are interchangeable no matter which opener you choose.....Also will fit the Bergeon 64.5700 case opener.

#67.7325 - complete selection of Suction Heads for screw back covers.

Individual suction cups.

- 67.7325-016 - 16mm suction cup
- 67.7325-020 - 20mm suction cup
- 67.7325-023 - 23mm suction cup
- 67.7325-026 - 26mm suction cup
- 67.7325-030 - 30mm suction cup
- 67.7325-034 - 34mm suction cup
- 67.7325-040 - 40mm suction cup



Individual Rolex dies.

- Replacement chuck 18.5mm 67.7326-185
- Replacement chuck 20.2mm 67.7326-202
- Replacement chuck 22.5mm 67.7326-225
- Replacement chuck 26.5mm 67.7326-265
- Replacement chuck 28.3mm 67.7326-283
- Replacement chuck 29.5mm 67.7326-295
- Set of all 6 chucks only 67.7326

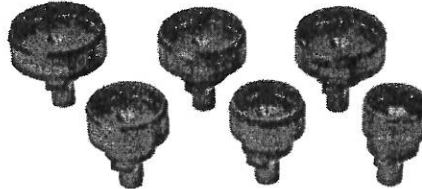

Individual Baume & Mercier dies.

- Replacement die 25.0mm 67.7327-025
- Replacement die 30.0mm 67.7327-030
- Replacement die 33.0mm 67.7327-033
- Set of all 3 chucks only #67.7327

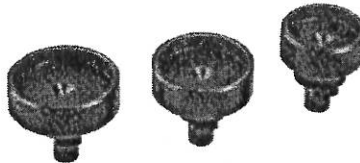

Individual 15 sided Breitling die. (special die only for Gent's Breitling watch cases)

Die only - 15 sided gents #67.7328

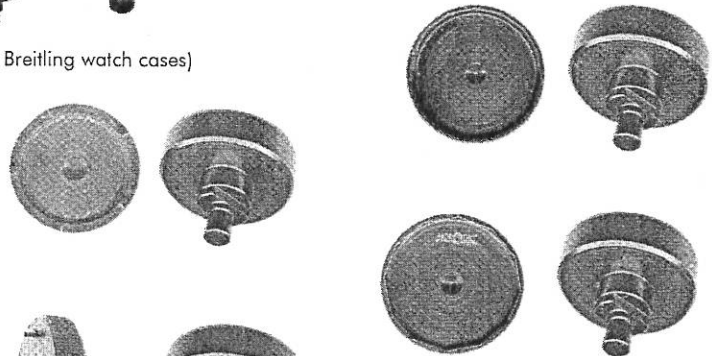

Individual CITIZEN AQUALAND die.

Die only - citizen aqualand #67.7331

Individual PANERAI die.

Die only - 12 sided dia. 39mm #67.7332

Individual Omega Seamaster dies

- 20mm Omega Seamaster die 67.7330-020
- 30mm Omega Seamaster die 67.7330-030
- Set of both chucks only 67.7330

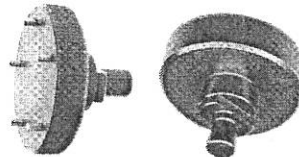

Removable case holder with 4 concave pins #67.7321

Replacement concave pins 67.7322

Replacement vise (pin holder) 67.7324

Replacement pins - round holes 67.7323-A

Replacement pins - flat edges 67.7323-B

Replacement pins - square holes 67.7323-C

Replacement pins - Milled (fluted edges) 67.7323-D

Replacement pins - extra height rectangular holes 67.7323-E

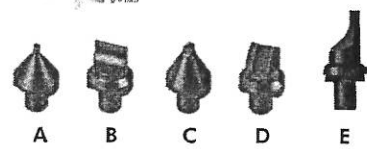
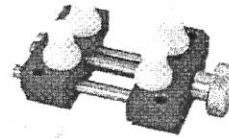
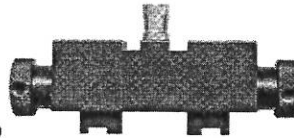

This is not included with the case openers, however it is available as a separate item

4Reversible case holding jaws 9-11 67.7360-C

Reversible case holding jaws 13-15 67.7360-D

Reversible case holding jaws 17-19 67.7360-E

Reversible case holding jaws 20-22 67.7360-F



Removable watch case vise 67.7360-A

Individual Delrin dies to fit watch case holder 67.7360-B

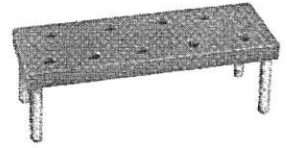
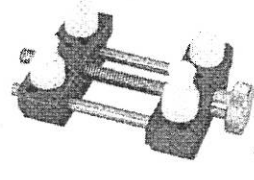

Table only to hold additional dies 67.7370

CASE TUBE INSERTERS & CASE TUBE TAPS.

These are specialized wrenches with a splined end to engage with, and insert into the case, the threaded case tubes of Rolex watches. A must have for anyone doing Rolex case repairs

67.3660 - Tube inserter for 530 Rolex tubes - case tube model 24-5300

67.3662 - Tube inserter for 530 Rolex tubes - case tube model 24-5302

67.3663 - Tube inserter for 530 Rolex tubes - case tube model 24-5304

67.3661 - Tube inserter for 600 Rolex tubes - case tube model 24-6000

67.3664 - Tube inserter for 600 Rolex tubes - case tube model 24-6020

67.3665 - Tube inserter for 600 Rolex tubes - case tube model 24-6040

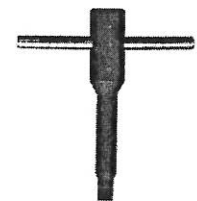

To compliment these tubes, we suggest the use of these special taps designed for Rolex tubes. Normal taps cannot be used for Rolex case repairs as the pitch of the taps are different. Special fine thread taps for cutting the threads in the side wall of Rolex cases for the screw in case tubes. A necessary tool if you encounter a case with a damaged thread or need to convert an old case to accept a more current crown and tube.

We can offer you the taps for the two most popular Rolex tubes.

67.22601 - 2.50mm thread suitable for the 530 and 5302 Rolex tubes

67.22602 - 3.00mm thread suitable for the 600 and 6020 Rolex tubes.

67.30969 - set of 2 taps for 530 and 600 Rolex case tubes. (alternative more affordable set)



#67.7110 "HOROTEC SWISS" MICRO PRESS

This is a scaled down case press that does the same job as the bigger tools, but can still be put away in the drawer. Supplied with 6 reversible Delrin dies. Can be fastened to the bench or left portable.

The big advantage to this type of threaded press is that you control the amount of pressure you are applying to the watch case, thus eliminating the possibility of damage. This tool is a case press only, not recommended for crystal fitting. Constructed of aluminum and stainless steel.

Dimensions 80mm x 60mm x 130mm

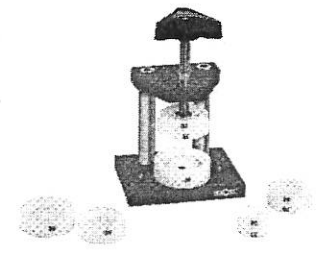

#67.7105 "HOROTEC SWISS" MICRO PRESS - THREADED DIES

This is a scaled down case press that does the same job as the bigger tools, but can still be put away in the drawer.

Supplied with 9 screw-on dies, Ideally suited for closing snap-back watch cases. Can be fastened to the bench or left portable. The big advantage to this type of threaded press is that you control the amount of pressure you are applying to the watch case, thus eliminating the possibility of damage. This tool is a case press only,

not recommended for crystal fitting. Constructed of aluminum and stainless steel.

Dimensions 80mm x 60mm x 135mm

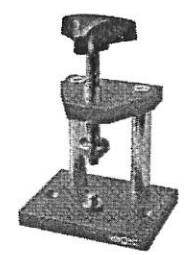

#67.7151 "SPEED PRESS"

This press has an innovative design that incorporates an external and an internal thread on the vertical shaft. The heavy exterior thread advances the dies up and down very rapidly. When the die makes contact with the watch, a fine interior thread takes over. The fine internal thread advances very slowly and provides greater sensitivity and more torque. This allows more precise control when fitting mineral crystals or closing case backs. Supplied with 8 Delrin dies. Dimensions 90mm x 100mm x 75mm

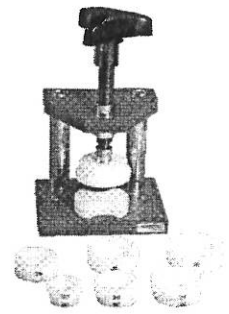

#67.6135 HOROTEC SWISS STANDARD PRESS

This standard press is built to last. The handle is designed to fit very nicely in your hand, allowing you comfort and maximum strength for fitting watch crystals or case backs. The press is sold separately, and then you can purchase the sets of different dies to best suit your repair requirements. This press is the "new kid" on the block. It's construction is robust, this is a tool that will last for years.

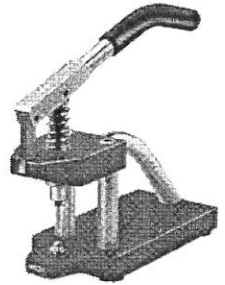

#67.6150 DELUXE HOROTEC CRYSTAL PRESS

This Deluxe press has a screwing system with blocking lever, that is designed to avoid damage to watch cases. Some watch cases require considerable pressure to either fit a watch glass or to close a watch case. The blocking lever on this press allows you to apply pressure by squeezing the handle and locking it in place. The final pressure can then be attained by turning the wheel on the top of the press. This allows you to control exactly the amount of pressure being applied to the watch case, thus avoiding the chance of inadvertently damaging a watch case. The press is sold separately, and then you can purchase the sets of different dies to best suit your repair requirements

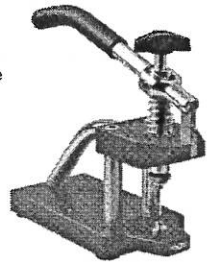

#67.6152 DELUXE HOROTEC PRESS COMPLETE SET

This is the identical press as the 67.6150 DELUXE HOROTEC CRYSTAL PRESS, supplied in a wooden case with a 2 drawer unit consisting of 48 Delrin snap on dies. The set, the DELUXE PRESS, 2 drawer wooden case, 20 dies for fitting tension ring crystals, set of 12 dies for fitting watch case bezels, set of 10 dies for fitting mineral crystals, and a set 6 dies for closing snap on watch case backs. This is the most complete set available, organized, ready to use for every application.



ACCESSORIES FOR THE HOROTEC STANDARD, DELUXE CRYSTAL PRESS, MICRO PRESS AND SPEED PRESS

Over the last few years Horotec has modified there crystals presses and case presses. The older models take dies with a hole only and friction fit. The newer models have a threaded brass bushing, and must be threaded on. Please be careful when ordering.

OLD MODEL DELRIN DIES - FRICTION FIT

These assortments of dies are suitable to fit 67.7110, 67.7151, 67.6125, & 67.6130 allowing you to achieve any desired function associated with your HOROTEC press.

- 67.6500 - Set of 20 delrin dies for fitting tension ring watch crystals
- 67.6505 - set of 12 delring dies for fitting bezels
- 67.6510 - set of 10 delrin dies for fitting flat mineral crystals.
- 67.7111 - set of 6 delrin dies for closing snap-on watch case backs

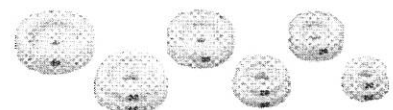
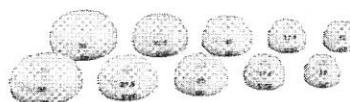
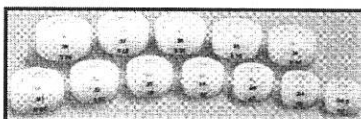
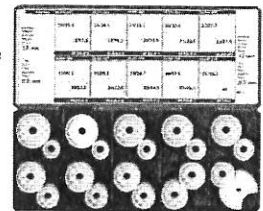

INDIVIDUAL DELRIN DIES (put in chart form to save on space - perhaps a smaller font - not used often by customer)

All dies are available separately

tension ring crystals. 67.6500	Bezels 67.6505	Mineral crystals 67.6510	snap-on watch back 67.7111
36/35.5 67.6500-A01	38.5/38 67.6505-A01	upper 40/35 67.6510-A01	upper 35/32 67.7111-A01
35/34.5 67.6500-A02	37.5/37 67.6505-A02	upper 32.5/27.5 67.6510-A02	upper 29/26 67.7111-A02
34/33.5 67.6500-A03	36.5/36 67.6505-A03	upper 30/25 67.6510-A03	upper 23/20 67.7111-A03
33/32.5 67.6500-A04	35.5/35 67.6505-A04	upper 22.5/17.5 67.6510-A04	lower 39 67.7111-B01
32/31.5 67.6500-A05	34.5/34 67.6505-A05	upper 20/15 67.6510-A05	lower 29 67.7111-B02
31/30.5 67.6500-A06	33.5/33 67.6505-A06	lower 40/35 67.6510-B01	lower 26 67.7111-B03
30/29.5 67.6500-A07	32.5/32 67.6505-A07	lower 32.5/27.5 67.6510-B02	
29/28.5 67.6500-A08	31/30 67.6505-A08	lower 30/25 67.6510-B03	
28/27.5 67.6500-A09	29/28 67.6505-A09	lower 33.5/17.5 67.6510-B04	
27/26.5 67.6500-A10	27/26 67.6505-A11	lower 20/15 67.6510-B05	
26/25.5 67.6500-A11	23/22.5 67.6505-A12		
25/24.5 67.6500-A12			
24/23.5 67.6500-A13			
23/22.5 67.6500-A14			
22/21.5 67.6500-A15			
21/20.5 67.6500-A16			
20/19.5 67.6500-A17			
19/18.5 67.6500-A18			
18/17.5 67.6500-A19			
lower die 40.0 67.6500-B			

NEW EXECUTION DELRIN DIES - THREADED FIT.

These assortments of dies are suitable to fit 67.6152, 67.6135, 67.7105, will also fit Bergeon presses with threaded shafts.

67.6520 - Set of 8 dies for flat mineral crystals



67.6521 - Set of 11 dies for fitting watch bezels

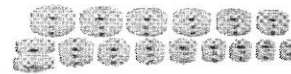

67.6522 - Set of 15 dies for tension ring crystals

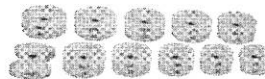

67.7106 - Set of 9 dies for snap-on case backs

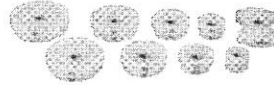

67.7107 - Set of 5 dies for the "BIG SIZE" WATCHES, 2 dies for snap backs, 1 for mineral crystals, 2 for bezels.

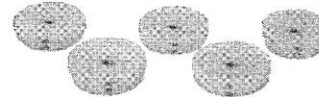

INDIVIDUAL DELRIN DIES.

All dies are available separately

Tension ring crystals. 67.6522	Bezels 67.6521	Mineral crystals 67.6520	Snap-on watch back 67.7106
15 67.6522-15	25/26 67.6521-2526	16 67.6520-16	17 67.7106-17
16/17 67.6522-1617	27/28 67.6521-2728	22/17 67.6520-2217	19/21 67.7106-1921
18/19 67.6522-1819	29/30 67.6521-2930	28/23 67.6520-2823	22/25 67.7106-2225
20/21 67.6522-2021	31/32 67.6521-3132	34/29 67.6520-3429	26/29 67.7106-2629
22/23 67.6522-2223	33/33.5 67.6521-3333	40/35 67.6520-4035	30/33 67.7106-3033
24/25 67.6522-2425	34/34.5 67.6521-3434	46/41 67.6520-4641	34/37 67.7106-3437
26/27 67.6522-2627	35/35.5 67.6521-3535	cal'd window 67.6520-A	38/41 67.7106-3841
28/29 67.6522-2829	36/36.5 67.6521-3636	45 universal 67.7106-U	42/46 67.7106-4246
30/31 67.6522-3031	37/37.5 67.6521-3737		45 universal 67.7106-U
32/33 67.6522-3233	38/38.5 67.6521-3838		
34/35 67.6522-3435	45 universal 67.7106-U		
36/37 67.6522-3637			
38/39 67.6522-3839			
40/41 67.6522-40/41			
45 universal 67.7106-U			

#67.7107 BIG SIZE INDIVIDUAL DELRIN DIES.

<u>Bezels</u>	<u>Mineral crystals</u>	<u>Snap on watch back</u>
40/45 67.6521-4045	47/50 67.6520-4750	47/48 67.7106-4748
46/50 67.6521-4650		49/50 67.7106-4950

#67.9304 OVERSIZE CASING CUSHION.

Diameter 80mm, ideal size for both wrist and pocket watches.

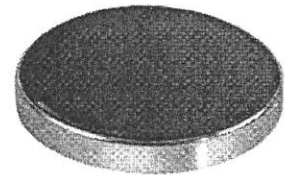

ELECTROSTATIC PROTECTIVE PADS.

These "electrostatic protective pads" avoid damage to watch cases, watch backs, watch crystals. Available in 3 sizes, helps to eliminate finger prints and to prevent scratches when working with or on watches and watch cases. Supplied in packages of 100 pieces.

- 67.70003-16 - 16mm diameter - suitable for ladies watches
- 67.70003-25 - 25mm diameter - suitable for men's watches
- 67.70003-36 - 36mm diameter - suitable for large divers type watches.

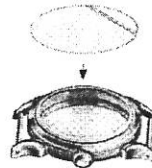

#67.12800 HOROTEC DEMAGNET

This is an electronic demagnetizer for very small parts. Designed to demagnetise tweezers, screwdrivers, and very small watch parts such as hairsprings.



#67.12803 HOROTEC DEMAGNETPRO ELECTRONIC DEMAGNETIZER

Allows for easy demagnetizing of watch parts. Simply place part to be demagnetized on the center area and push the button for 2 to 3 tenths of a second and most parts will be demagnetized in one operation. Parts or tools that are larger than the middle zone may require the operation to be repeated. Supplied with an AC adaptor.



HOROTEC HEADBAND BINOCULAR

These is a very price effective headband, supplied with 4 interchangeable lenses, and a frontal light to provide better illumination. Ideally suited for clockmakers, watchmakers, jewellers, hobbist etc... Very light weight, visor is removable, supplied with 4 interchangeable lenses 1.2X, 1.8X, 2.5X, 3.5X, frontal light, adjustable headband. Batteries not included.

Order number #67.248

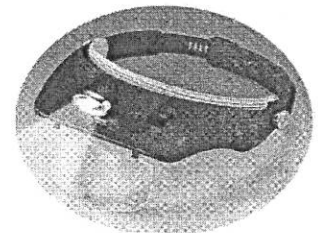

HOROTEC HAND REMOVING LEVERS.

Horotec has come out with 3 different sizes of levers for removing watch hands. Supplied in pairs.

- 67.5009 - Pair of levers 1.20mm in width
- 67.5007 - Pair of levers 2.50mm in width
- 67.5008 - Pair of levers 4.00mm in width.



"HOROTEC" SWISS TOOLS FOR FITTING WATCH HANDS.

Double ended tools for setting hands on watches. Anodized aluminum body with nylon tips. Cost effective alternative to the Bergeon quality hand fitting tools. The nylon tips prevent the scratching of watch hands when fitting. In today's market, with the increased amount of movement exchange, the fitting of hands has become a daily event. These tools make hand fitting easier. Replacement ends are available.

- 67.5010 1 side with hole 0.50mm, other side has a hole 1.00mm
- 67.5010A Nylon replacement tip white hole 0.50mm
- 67.5010B Nylon replacement tip green hole 1.00mm
- 67.5011 1 side is flat (no hole) the other side has a hole of 0.80mm.
- 67.5011A Nylon replacement tip violet no hole
- 67.5011B Nylon replacement tip yellow hole 0.80mm
- 67.5012 1 side with hole 1.50mm, other side has a hole 2.00mm
- 67.5012A Nylon replacement tip black hole 1.50mm
- 67.5012B Nylon replacement tip red hole 2.00mm

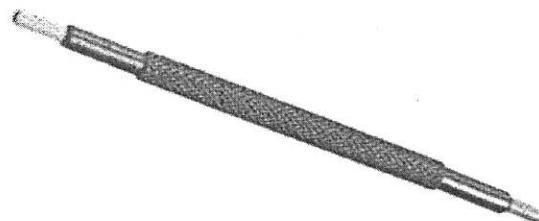

#67.5015 HOROTEC WATCH HAND PRESS.

This well made jig allows hands to be fitted quickly without chance of marking or damaging hands or dial. Constructed with machined aluminum platforms and steel pillars. The plunger held in perfect vertical alignment and controlled by light pressure with the index finger. A return spring lifts the plunger automatically when pressure is removed. Tool comes with 8 different nylon end pieces for the plunger and can be used for all sizes of watch movements. A very simple and effective tool.

- Replacement parts:
- Nylon end 0.50mm order number 67.5015A
 - Nylon end 0.70mm order number 67.5015B
 - Nylon end 0.90mm order number 67.5015C
 - Nylon end 1.20mm order number 67.5015D
 - Nylon end 1.50mm order number 67.5015E
 - Nylon end 1.70mm order number 67.5015F

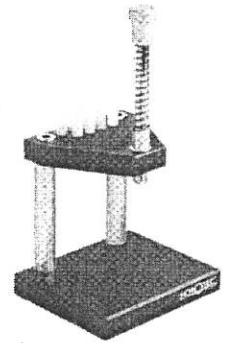

#67.5017 HOROTEC 3 BROACH WATCH HAND PRESS

Same quality hand press as model 67.5015. The major difference is that this unit has 3 - broaches affording you the use of the press without always having to change the nylon stakes, speeding up the hand fitting process.

- Replacement parts:
- Nylon end 0.50mm order number 67.5017A
 - Nylon end 0.70mm order number 67.5017B
 - Nylon end 0.90mm order number 67.5017C
 - Nylon end 1.20mm order number 67.5017D
 - Nylon end 150mm order number 67.5017E
 - Nylon end 170mm order number 67.5017F
 - Nylon end flat order number 67.5017G
 - Nylon end concave order number 67.5017H
 - Broach (plunger) order number 67.5017-01
 - Spring order number 67.5017-02

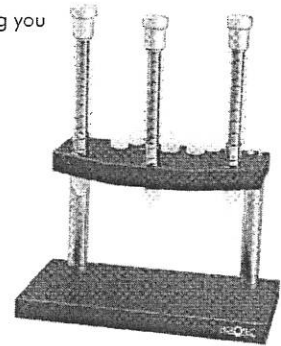

#67.5001 "HOROTEC SWISS" HAND BROACHING TOOL

Spring loaded tool for holding watch hands while broaching. Broaching is required to increase the hole sizes of both minute and hour hands when fitting hands to watches. This tool allows you to broach the holes in watch hands safely without damaging or bending the hands. The tool is clamped firmly in place while you make the adjustment of the hole size. Due to the large number of quartz movement retrofits, hand adjustments have become a daily event, making this tool a necessity.

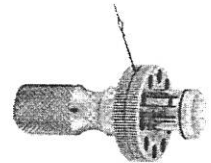

#67.4039 HOROTEC SWISS SMALL MOVEMENT HOLDER.

Fine quality steel holders, smooth and precise. This reversible holder adjusts to accept watch movements from 3 3/4 ligne to 11 ligne movements. A quality cost effective movement holder.

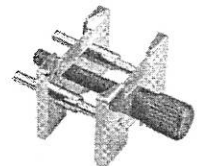

#67.90002 HOROTEC SPRING LOADED SMALL MOVEMENT HOLDER

This reversible holder adjusts to accept watch movements from 3 3/4 ligne to 12 1/2 ligne movements. Spring loaded allows the movement holder to adjust quickly to different sizes.

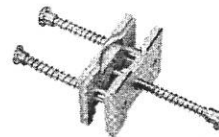

#67.4040 HOROTEC SWISS LARGE MOVEMENT HOLDER.

Fine quality steel holders, smooth and precise. This reversible holder adjusts to accept watch movements from 8 3/4 ligne to 19 ligne movements. A quality, cost effective movement holder.

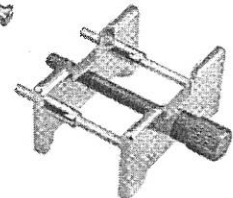

#67.90050 HOROTEC OVERSIZE REVERSIBLE MOVEMENT HOLDER

Designed like the most popular wrist movement holders but scaled up to accommodate any size of pocket watch movement. Good quality, works well.

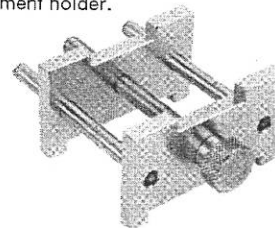

MOVEMENT HOLDERS FOR ROLEX CALIBERS.

Designed by HOROTEC these movement holders have been designed for specific Rolex calibers

67.9010-26 movement holder for Rolex 1530 / 1570

67.9010-24 movement holder for Rolex 2135

67.9010-25 movement holder for Rolex 30351

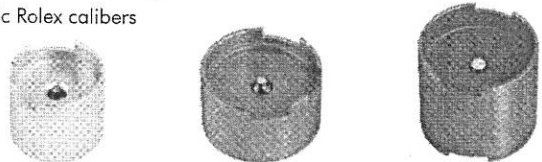

HOROTEC ALUMINIUM HANDLE OILERS.

- 67.17000-E black very small
- 67.17000-D blue small
- 67.17000-C green medium
- 67.17000-A large red

#67.17000-04 Assortment of 1 each of 4 colours.

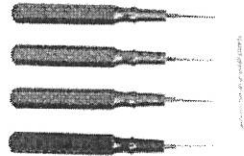

ROTOR AXLE PUNCHES FOR ROLEX WATCHES.

These punches have been designed to install rotor axles on specific Rolex Calibers .

67.3666 Rotor axle punch for ROLEX calibers 1530, 1520, 1570 etc.

67.3667 Rotor axle punch for ROLEX caliber 2135

67.3669 Rotor axle punch for ROLEX caliber 2235

67.3668 Rotor axle punch for ROLEX caliber 3035 and 3135

#67.3666-4 Set of 4 Rotor axle punches for ROLEX calibers 1570, 2135, 2235, 3135

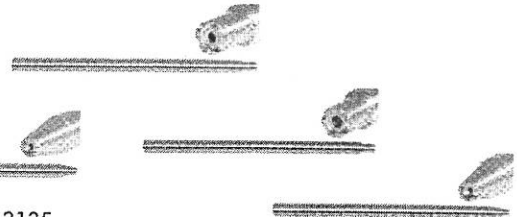

#67.3654 TOOL FOR REMOVING FRICTION-FIT PUSHERS AND CROWN TUBES.

Small press for pushing out friction-fit pushers and the tubes of screwdown crowns. Supplied with 7 stakes which have a diameter range of 1.55mm to 2.90mm. The vast number of multi-function watches with pushers and waterproof cases with a screwdown crown that are presently on the market make this tool a necessity.

To use just insert the stake which best matches the diameter of the pusher or tube. Place the case on the nylon protector and turn the knob slowly to advance the stake. This tool provides the mechanical advantage needed to perform this task in a controlled manner. Height 80mm x width 45mm x depth 60mm.

- Replacement parts:
- Replacement die * Hole 1.55mm * Diameter 2.95mm # 67.3654A
 - Replacement die * Hole 1.55mm * Diameter 2.65mm # 67.3654B
 - Replacement die * Hole 1.55mm * Diameter 2.45mm # 67.3654C
 - Replacement die * Hole 1.55mm * Diameter 2.15mm # 67.3654D
 - Replacement die * Hole 1.45mm * Diameter 1.95mm # 67.3654E
 - Replacement die * Hole 1.75mm * Diameter 1.75mm # 67.3654F
 - Replacement die * Hole 1.55mm * Diameter 1.55mm # 67.3654G

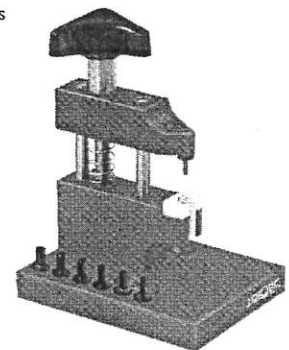

#67.3656 TOOL FOR FITTING AND REMOVING FRICTION FIT PUSHERS AND CROWN TUBES.

This HOROTEC quality tool is the step up from model 67.3654. Exact same tool as the model 67.3654 with the addition of nylon stakes for inserting friction pushers and crown tubes.

- Replacement parts - Bottom nylon stake #67.3656-A
- Top nylon stake # 67.3656-B

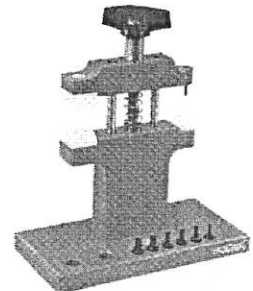

#67.3655 TOOL FOR INSERTING AND REMOVING ROLEX DAYTONA PUSHERS.

This inserter is used when removing and installing Rolex Daytona pushers.

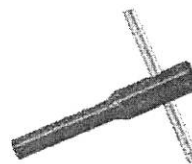

#67.19106 HOROTEC IMPULSE DETECTOR

Detects and amplifies the impulses given off by the electronic side of a quartz watch. The unit also gives a visual indicator of flashing lights. If a quartz movement does not appear to be working, this device allows you to quickly determine if the source of the problem is electronic or mechanical without opening the watch.



#67.19107 HOROTEC TURBO

Device for unjamming and testing the wheel train of quartz watches. The Turbo emits a series of high speed impulses which cause the gear train to operate at 60 times it's usual speed. Can be used to kick start movements, find defects in the wheel train or to check that hands are clearing each other and clearing dial markers.



#67.19110 HOROTEC TURBOPULSE

Horotec has combined the features of the Impulse Detector # 67.19106 and the Turbo # 67.19107 in one piece of equipment. Simply place a watch on the cushioned "Check Spot" and push on the button. This will activate the Impulse checking feature which detects the impulse put out by the circuit and coil. Each impulse is represented by a flashing light and audible beep tone. A steady impulse indicates that the electronic components are in working order, and if the watch is not proceeding then the problem is mechanical in nature. The Turbo feature can be activated by simply pressing and holding on the button. This will cause the unit to put out an accelerated series of impulses. The hands will now spin around at the rate of 1 hour in 1 minute. This will free up the gear train move lubricants around in a watch that has been sitting idle. Operates on a 9 volt battery (not included) or an AC adapter (supplied)

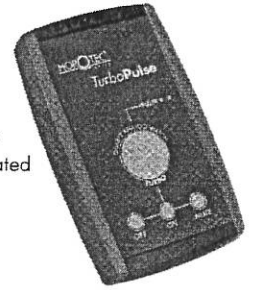

#67.19108 HOROTEC FLASHTEST - MULTI FUNCTION QUARTZ TESTER.

The FLASHTEST is a multi-function portable tester for analog quartz watches and watch movements. Supplied with 2 precision probes, 9V AC adapter, 9V battery, instructions for use and a technical guide on movement consumption and coil resistance values of popular quartz movements.

Without opening the watch the FLASHTEST can perform quick tests on electronic parts such as the battery, electronic circuit, coil and step motor. It has a turbo feature that can be used to unjam the wheel train, check that hands are turning free and clear, and check that calendar functions are operating properly.

These tests can quickly determine if a malfunction is caused by an electronic or mechanical fault.

When a watch is opened the FLASHTEST can perform tests of the real battery status (load test), consumption of the electronic circuit, consumption of movement and the coil continuity. Tests performed on the opened watches are necessary to get precise information on the status of vital components. The extra large digits give quick and easy readings on the large LCD panel. The battery test function will test from 0 to 19.999 volts.

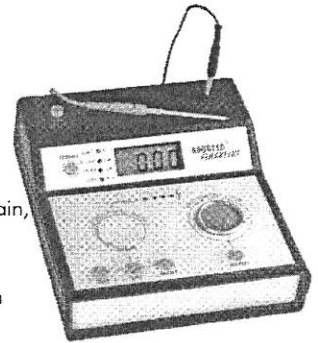

#67.7115 HOROTEC BEZEL REMOVER

Horotec swiss bezel remover. This is a 2 - jaw style bezel remover, can also be used as a snap-back watch case opener. This tool uses mechanical advantage to drive chisel tips in between case and rotating bezel by applying controlled pressure, slowly lifting the bezel away from the case.

Supplied with 2 sizes of replacement blades.

Complete tool 67.7115

Replacement blade 2.0mm 67.7115A

Replacement blade 4.0mm 67.7115B

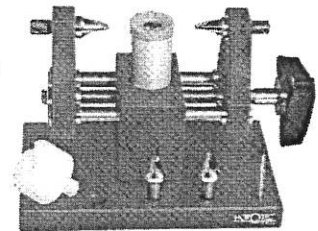

#67.3621 MULTI PURPOSE WATCHMAKERS REMOVERS AND INSERTERS.

Made by Horotec this set contains 3 keys for removing the battery hatch covers of "Swatch" brand watches plus 2 heads for inserting and removing the weight bearings for calibers ETA 2892-2 & ETA 7750. In addition there are 5 keys for inserting and removing screw-in type pushers and 7 keys for inserting screw-in type case pipes for Rolex style screwdown crowns. All these keys plug into a handle provided. All components are well finished and store in a solid metal base. 17 possible functions with one tool.

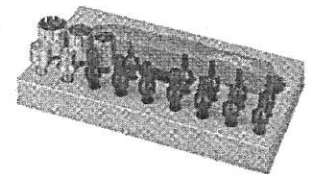

#67.3622 MULTI PURPOSE WATCHMAKERS REMOVERS AND INSERTERS - REDUCED VERSION

Same concept as model 67.3621 without the 3 hatch cover keys and with weight bearing keys. Still a very useful tool for inserting and removing screw-in type pushers and Rolex style screw down crowns.

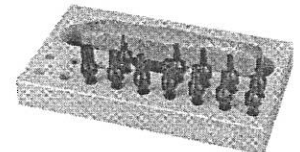

#67.3623 MULTI PURPOSE WATCHMAKERS REMOVERS AND INSERTERS - REDUCED VERSION

Same concept as model 67.3621 without the 3 hatch cover keys. Still a very useful tool for inserting and removing screw-in type pushers and Rolex style screwdown crowns, as well inserting and removing the weight bearings for calibers ETA 2892-23 & ETA 2750

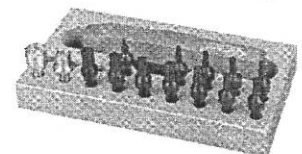

#67.3675 HOROTEC TOOL TO RELEASE AND LOCK THE BOLT OF OSCILLATING WEIGHTS.

Identical tool as the number 64.6923.

Tool is supplied with 2 interchangeable heads allowing you to unlock the weight bolts of

ETA calibers 2891 - 2892 - 2892-A2 - 2893 - 2894 CHRONO

- plus ETA 7750 chrono calibers & ETA 2000-1

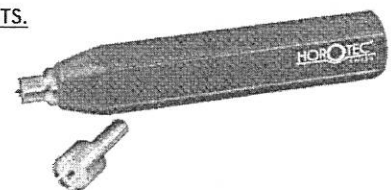

HOROTEC SWISS - QUALITY SCREWDRIVERS.

These are top quality stainless steel bodied screwdrivers with colour coded, anodized aluminum heads which pivot smoothly on ball bearings. These screwdrivers are not chrome plated and therefore eliminate all risk of possible problems due to plating flaking off the screwdrivers.

Available in assortments or individually

INDIVIDUAL SIZES. & SPARE BLADES		Screwdriver	blades pkg of 5
Blade diameter	Colour	order number	order number
0.50	Orange	67.1201-050	67.1102-10
0.60	White	67.1201-060	67.1102-09
0.70	Khaki	67.1201-070	67.1102-11
0.80	Yellow	67.1201-080	67.1102-08
0.90	Pink	67.1201-090	67.1102-16
1.00	Black	67.1201-100	67.1102-07
1.10	Turquoise	67.1201-110	67.1102-14
1.20	Red	67.1201-120	67.1102-06
1.30	Light green	67.1201-130	67.1102-15
1.40	Dark grey	67.1201-140	67.1102-05
1.50	Salmon	67.1201-150	67.1102-12
1.60	Violet	67.1201-160	67.1102-04
1.80	Light grey	67.1201-180	67.1102-13
2.00	Dark green	67.1201-200	67.1102-03
2.50	Blue	67.1201-250	67.1102-02
3.00	Brown	67.1201-300	67.1102-01

HOROTEC QUALITY SCREWDRIVER ASSORTMENTS.

#67.1201A SET OF 9 HOROTEC QUALITY SCREWDRIVERS IN WOODEN BOX.

Set of 9 top quality watchmakers screwdrivers. Includes sizes 0.80 - 0.80 - 1.00 - 1.20 - 1.40 - 1.60 - 2.00 - 2.50 - 3.00mm. Screwdrivers are nicely organized in a wooden box with a hinged lid, allowing the screwdrivers to be stored away in a drawer, keeping them dust free. A capsule of spare blades is included in the box.

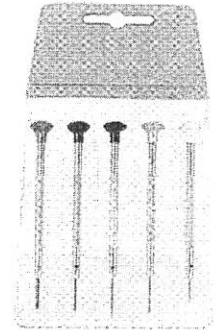

#67.1201B SET OF 5 HOROTEC QUALITY STEEL SCREWDRIVERS.

Set of 5 top quality stainless steel, ball bearing screwdrivers supplied in a plastic pouch. Most common sizes for general watch repair are included in this set. Sizes are: 0.60 - 0.80 - 1.00 - 1.20 - 1.40mm.

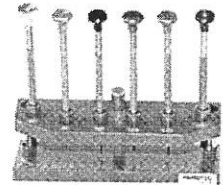

#67.1201C SET OF 12 HOROTEC QUALITY SCREWDRIVERS SUPPLIED IN A ROTATING STAND.

This is the deluxe set of HOROTEC screwdrivers. Set includes 12 top quality stainless steel watchmakers screwdrivers with a weighted rotating stand. At the center of the stand is a hole organized to hold spare blades, covered with a lid. This is the most comprehensive assortment available. Sizes included in the set are 0.50 - 0.60 - 0.70 - 0.80 - 1.00 - 1.20 - 1.40 - 1.50 - 1.60 - 2.00 - 2.50 - 3.00. This set allows you to have easy access to the full range of Horotec quality screwdrivers directly on your bench with no clutter.

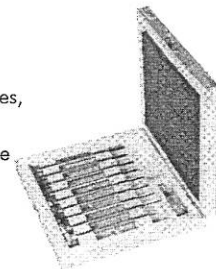

#67.1201D SET OF 6 HOROTEC QUALITY SCREWDRIVERS WITH ALUMINUM STAND.

Set of six top quality watchmakers screwdrivers. Includes sizes 0.60 - 0.80 - 1.00 - 1.20 - 1.40 - 2.00mm. The stand is constructed of aluminum and stainless steel. Screwdrivers are set into the stand at an angle that makes this stand very user friendly. A compartment of spare blades is built into the stand.

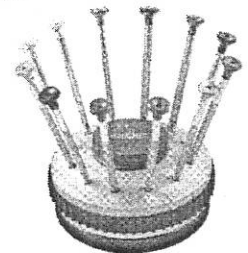

#67.2019 STEEL PIN VICE FOR USE WITH YOUR STAKING TOOL

This tool is supplied by HOROTEC, to add versatility to your staking tool. Consists of 1 steel handle with 4 interchangeable heads measuring 0.80, 1.00, 1.20 and 1.50mm.

This pin vice adds a lot of versatility to your staking tool. Has a threaded collar for height adjustment.

