



# AudioPressBox®

## APB-D200 R

Press Conference Audio Distribution Amplifier  
Owner's manual

English



**Always follow the basic precautions listed below to avoid the possibility of serious injury or even death from electrical shock, short-circuiting, damages, fire or other hazards. These precautions include, but are not limited to, the following:**

## **WARNING**

---

### **Power supply/Power cord**

- Only use the voltage specified as correct for the device. The required voltage is printed on the name plate of the device.
- Use only the specified AC power adaptor.
- Do not place the power cord near heat sources such as heaters or radiators, and do not excessively bend or otherwise damage the cord, place heavy objects on it, or place it in a position where anyone could walk on, trip over, or roll anything over it.

### **Do not open**

- Do not open the device or attempt to disassemble the internal parts or modify them in any way. The device contains no user-serviceable parts. If it should appear to be malfunctioning, discontinue use immediately and have it inspected by qualified AudioPressBox service personnel.

### **Water warning**

- Do not expose the device to rain, use it near water or in damp or wet conditions, or place containers on it containing liquids which might spill into any openings.
- Never insert or remove an electric plug with wet hands.

### **If you notice any abnormality**

- If the power cord or plug becomes frayed or damaged, or if there is a sudden loss of sound during use of the device, or if any unusual smells or smoke should appear to be caused by it, immediately turn off the power switch, disconnect the electric plug from the outlet, and have the device inspected by qualified AudioPressBox service personnel.
- If this device or the AC power adaptor should be dropped or damaged, immediately turn off the power switch, disconnect the electric plug from the outlet, and have the device inspected by qualified AudioPressBox service personnel.



**Always follow the basic precautions listed below to avoid the possibility of physical injury to you or others, or damage to the device or other property. These precautions include, but are not limited to, the following:**

## **CAUTION**

---

### **Power supply/Power cord**

- Remove the electric plug from the outlet when the device is not to be used for extended periods of time, or during electrical storms.
- When removing the electric plug from the device or an outlet, always hold the plug itself and not the cord. Pulling by the cord can damage it.
- To avoid generating unwanted noise, make sure there is 50cm or more between the AC power adaptor and the device.
- Do not cover or wrap the AC power adaptor with a cloth or blanket.

### **Location**

- Before moving the device, remove all connected cables.
- When setting up the device, make sure that the AC outlet you are using is easily accessible. If some trouble or malfunction occurs, immediately turn off the power switch and disconnect the plug from the outlet.
- Avoid setting all controls to their maximum. Depending on the condition of the connected devices, doing so may cause feedback and may damage the speakers.

- Do not expose the device to excessive dust or vibrations, or extreme cold or heat (such as in direct sunlight, near a heater, or in a car during the day) to prevent the possibility of panel disfiguration or damage to the internal components.
- Do not place the device in an unstable position where it might accidentally fall over.

#### **Connections**

- Before connecting the device to other devices, turn off the power for all devices. Before turning the power on or off for all devices, set all volume levels to minimum.

#### **Handling caution**

- When turning on the AC power in your audio system, always turn on the power amplifier LAST, to avoid speaker damage. When turning the power off, the power amplifier should be turned off FIRST for the same reason.

- Do not insert your fingers or hands in any gaps or openings on the device.
- Avoid inserting or dropping foreign objects (paper, plastic, metal, etc.) into any gaps or openings on the device. If this happens, turn off the power immediately and unplug the power cord from the AC outlet. Then have the device inspected by qualified AudioPressBox service personnel.
- Do not use the device or headphones for a long period of time at a high or uncomfortable volume level, since this can cause permanent hearing loss. If you experience any hearing loss or ringing in the ears, consult a physician.
- Do not rest your weight on the device or place heavy objects on it, and avoid use excessive force on the buttons, switches or connectors.

XLR-type connectors are wired as follows (IEC60268 standard): pin 1: ground, pin 2: hot (+), and pin 3: cold (-).

AudioPressBox cannot be held responsible for damage caused by improper use or modifications to the device, or data that is lost or destroyed.

Always turn the power off when the device is not in use.

The performance of components with moving contacts, such as switches, volume controls, and connectors, deteriorates over time. Consult qualified AudioPressBox service personnel about replacing defective components.

Illustrations herein are for explanatory purposes only, and may not match actual appearance during operation.

Company names and product names herein are trademarks or registered trademarks of their respective companies.

Specifications and descriptions in this owner's manual are for information purposes only. AudioPressBox reserves the right to change or modify products or specifications at any time without prior notice. Since specifications, equipment or options may not be the same in every locale, please check with your AudioPressBox dealer.



**Use only the adaptor included with this AudioPressBox. Use of a different adaptor may result in equipment damage, overheating, or fire.**

**Be sure to unplug the adaptor from the outlet when not using AudioPressBox, or when there are lightning storms in the area.**

**To avoid generating unwanted noise, make sure there is 50 cm or more between the power adaptor and AudioPressBox.**



## APB-D200 R

Dear customer,

Thank you for purchasing **AudioPressBox® APB-D200 R**. This 2 channel drive unit can feed up to 96 Line/MIC Outputs. Each buffered expander output can power 24 Line/MIC outputs. It features the high-pass filter, compressor and limiter and of course gain. With **AudioPressBox®** you are set in a minute and you can provide the perfect signal to every reporter!

### **The package contains**

1. AudioPressBox unit.
2. Power supply.
3. Manual
4. Test report

# APB-D200 R - Front panel (Input section)

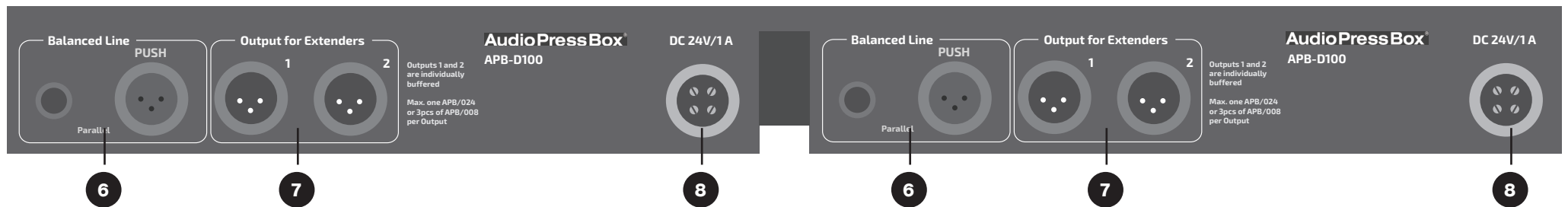
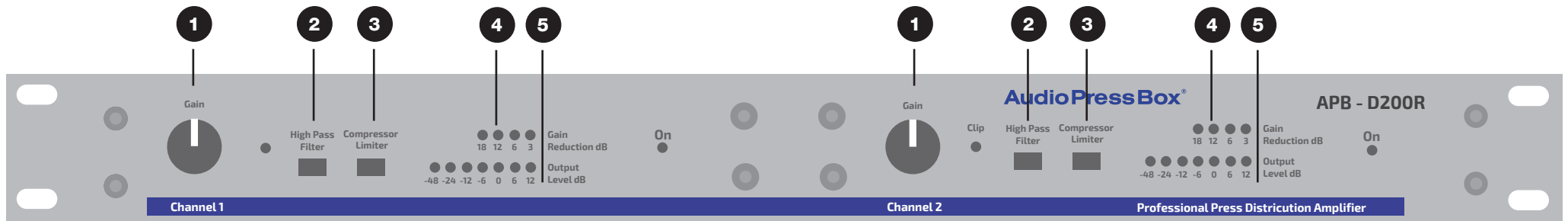

## 1) Input gain level knob

You can set the input signal level depending on the connected audio source to reach the optimal output level. You can check the output level on the Output level meter (5).

## 2) High Pass Filter switch

You can turn ON the HPF to eliminate low frequency disturbances like pops or microphone handling noise. The cut-off frequency of the HPF is 160Hz. It is very handy for speech. If you need to distribute the music or full-range signals it is handy to have the HPF switched off.

## 3) Compressor/Limiter switch

If you need to reduce the dynamics of the input signal and/or be sure that the output signal will not be higher

than the nominal output level please switch this button ON. Function of the compressor and limiter you can see on the Gain reduction level meter (6). It is very good for speech.

## 4) Gain reduction meter

## 5) Output level meter

## 6) Input Jack or XLR Line connector

You can connect your source device with 6,3mm JACK or 3-pin XLR connector. Inputs are balanced and line level only. JACK and XLR connectors are in parallel. (XLR pinout: 1: Ground; 2: Hot; 3: Cold).

## 7) Buffered XLR output for expanders

Output for connecting the AudioPressBox expanders (APB-008 SB-EX, APB-024 R-EX, APB-008 OW, APB-008 IW, APB-P112 SB) to provide up to 24 additional Line/MIC outputs. Output connector is a 3-pin XLR. Please do not connect other devices than AudioPressBox expanders!

## 8) Power supply connector

Plug the mains cable to AudioPressBox® here.

### Good to know:

#### What are compressor and limiter?

These elements automatically control your signal and provide the best signal condition for every output. You will get perfect signal without clipping or distortion. You can switch this element on or off for each input depending your needs.

# Specifications

## Audio Press Box APB-D200 R

Type 2 IN/ 4 Drive OUT for 12xAPB 8-Output expanders or 4xAPB 24- Output expander  
 Note: Total capacity:96 Line/Mic outputs (12x APB-008 xx-EX or 4x APB-024 R-EX)

### Input section

Inputs 2  
 Input connectors Balanced, XLR  
 Max. input level Line: +32/+2dBu  
 Input Impedance >5kOhm

### Output section

Outputs 4 separately buffered, balanced outputs for AudioPressBox expanders  
 Output connectors Balanced, XLR  
 Nominal Output Level +6dBu  
 Maximum Output Level +20dBu with 48 Outputs in use  
 +16dBu (600kOhm)  
 Output impedance MIC: 220 Ohm                      LINE: 600 Ohm

Transformer isolated outputs Yes (each EXPANDER output is Independant Transformer Isolated)  
 SNR 86dB at 0dB Gain  
 78dB at +20dB Gain  
 Frequency Response 30/160Hz (filter) to 60kHz/-1dB  
 Controls Input gain, Compressor and Limiter, High Pass Filter, Power  
 Indicators Input clip, Output level, Gain reduction, Power  
 Power Supply 24V DC, 300mA external adaptor

# Block diagram

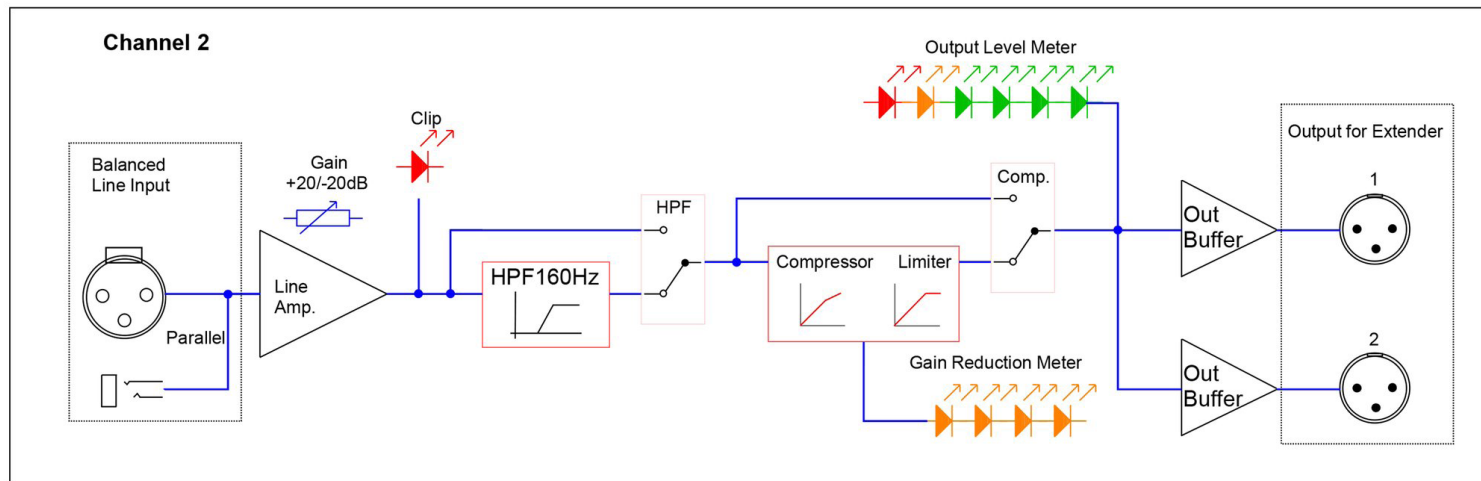
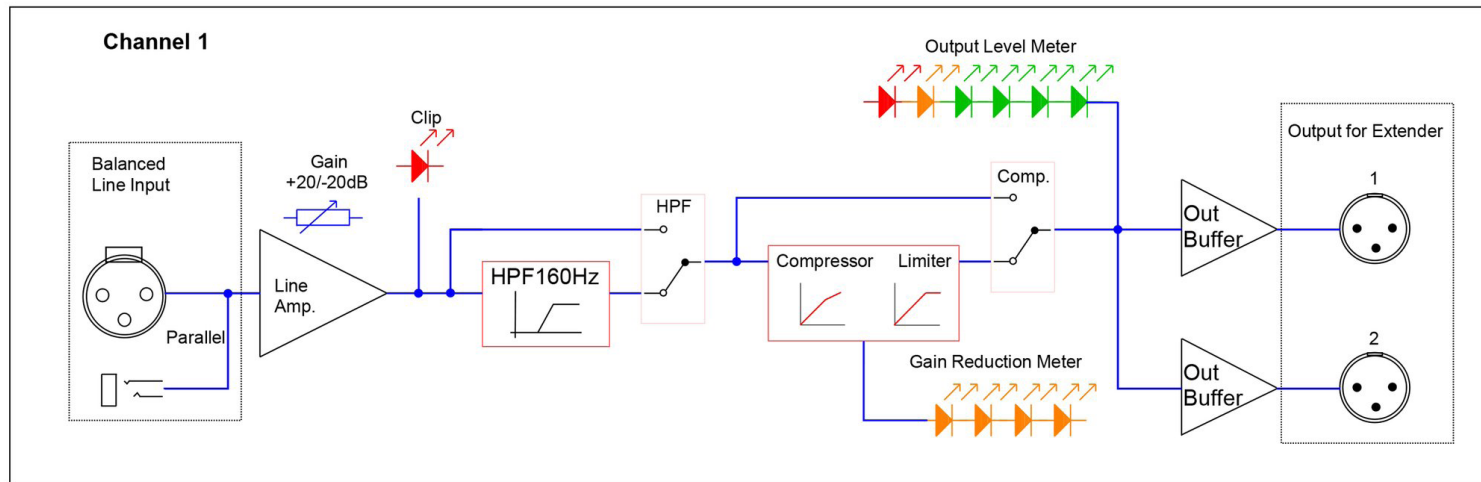

AudioPressBox<sup>™</sup>  
APB-D200 R

# Audio Press Box<sup>®</sup>

e-mail: [sales@audiopressbox.com](mailto:sales@audiopressbox.com) | web: [www.audiopressbox.com](http://www.audiopressbox.com)

MediaTech Central Europe, a.s., Drienova 34, 821 02 Bratislava, Slovak Republic (EU)  
Tel: +421 2 20 999 700