

# PIPE /TUBING NOTCHER

-Steel

Model PN-1/2S



Assembly & Operating Instructions

## TUBING NOTCHER SPECIFICATIONS

Construction	.224" Chrome plated frame
	.149" Black oxide steel clamp
	.485" Handle/clamp screw
Spindle dimensions:	3/4" with 1/2"-20 thread
Spindle adapter:	1/2" to 5/8"
Angle adjustment	0-60° Left
Mounting bracket	Adjustable
Net weight.	9.8 lbs.

## FEATURES OF THIS PRECISION PIPE NOTCHER

1. This precision pipe notcher is a useful fixture for your drill press, allowing you to make round cuts in pipes and tubing of various shapes at any angle from 0-60 degrees.
2. Sturdy and durable steel frame holds your workpieces rigid during operation.
3. Base is adaptable to any worktable, and is especially suited to be mounted on drill press tables.
4. The base may be swiveled and rotated, which in conjunction with the adjustable pipe holder makes cutting compound angles very easy.
5. Works with any standard drill press, and is adaptable to a large variety of round cutters, hole saws, and milling bits.

**Warning: when using this pipe notcher with any powered tool, observe all safety precautions relevant to that equipment. Refer to the owner's manual of the power equipment for safe practices in the use of attachments.**

### Save this manual

You will need the manual for the safety warnings and precautions, assembly instructions, operating and maintenance procedures, parts list and diagram. Keep your invoice with this manual. Write the invoice number on the inside of the front cover. Keep the manual and invoice in a safe and dry place for future reference.

### Safety warnings and precautions

**WARNING:** When using tool, basic safety precautions should always be followed to reduce the risk of person injury and damage to equipment.

**Read all instructions before using this tool!**

1. **Keep work area clean.** Cluttered areas invite injuries.

2. **Observe work area conditions.** Do not use machine or power tools in damp or wet locations. Don't expose to rain. Keep work area well lighted. Do not use electrically powered tools in the presence of flammable gases or liquids.
3. **Keep children away.** Children must never be allowed in the work area. Do not let them handle machines, tools, or extension cords.
4. **Store idle equipment.** When not in use, tools must be stored in a dry location to inhibit rust. Always lock up tools and keep out of reach of children.
5. **Do not force tool.** It will do the job better and more safely at the rate for which it was intended. Do not use inappropriate attachments in an attempt to exceed the tool capacity.
6. **Use the right tool for the job.** Do not attempt to force a small tool or attachment to do the work of a large industrial tool. Do not use a tool for a purpose for which it was not intended.
7. **Dress properly.** Do not wear loose clothing or jewelry as they can be caught in moving parts. Protective, electrically non-conductive clothes and non-skid footwear are recommended when working. Wear restrictive hair covering to contain long hair.
8. **Use eye and ear protection.** Always wear ISO approved impact safety goggles. Wear a full-face shield if you are producing metal filings or wood chips. Wear an ISO approved dust mask or respirator when working around metal, and chemical dusts and mists.
9. **Do not overreach.** Keep proper footing and balance at all times. Do not reach over or across running machine.
10. **Maintain tools with care.** Keep tools sharp and clean for better and safer performance. Follow instructions for lubricating and changing accessories. The handles must be kept clean, dry, and free from oil and grease at all times.
11. **Stay alert.** Watch what you are doing: use common sense. Do not operate any tool when you are tired.
12. **Check for damaged parts.** Before using any tool, any part that appears damaged should be carefully checked to determine that it will operate properly and perform its intended function. Check for alignment and binding of moving parts; any broken parts or mounting fixtures; and any other condition that may affect proper operation. Any part that is damaged should be properly repaired or replaced by a qualified technician.
13. **Guard against electric shock.** Prevent body contact with grounded surfaces such as pipes, radiators, ranges, and refrigerator enclosures.
14. **Replacement parts and accessories.** When servicing, use only identical replacement parts. Use of any other parts will void the warranty. Only use accessories intended for use with this tool. Approved accessories are available from the distributor.
15. **Do not operate tool if under the influence of alcohol or drugs.** Read warning labels on prescriptions to determine if your judgment of reflexes are impaired while taking drugs. If there is any doubt, do not operate the tool.

**Note:** The warning and instructions contained in this instruction manual cannot cover all

possible conditions and situations that may occur when using this product. It must be understood that common sense and caution are factors, which cannot be built into this product. These factors must be supplied by the person whom operating this piece of equipment.

## ASSEMBLY AND SETUP

**NOTE:** This notcher is designed for use with threaded, metal-cutting hole saws.

### **Basic assembly and set-up.**

1. This spindle (#7) is shipped in the reverse position. Remove it and re-insert it in the correct position prior to using the tool.
2. Your pipe notcher must be mounted to your drill press table, using the adjustable angle joint plate (#17). Depending on the configuration of your drill press table, you may use T- bolts, carriage bolts or standard machine bolts, washers and nuts. Hardware is not supplied.
3. After mounting, be sure that the spindle travels smoothly without binding against the bushings (#5). Any undue friction will cause excessive wear of the bushings.
4. The angle of the notcher can be adjusted by loosening the bolts (#16) that adjust the adjustable angle joint plate and moving assembly as necessary.
5. For side to side adjustments, loosen the bolts (#15) that hold the adjustment plate to the body(#13).
6. When installing the hole saw, check first to see if its arbor is 1/2" or 5/8". The thread on the spindle are for 1/2", however, there is an adapter (#3) for 5/8" models that can be screwed on over the 1/2" threads, you may need to use the adapter washer (#4) to assure a good, secure fit.
7. To install a saw blade or bit, first fix the spindle in place with the locking pin (#14). *Do not use locking pliers or clamps to hold the spindle*, as this will cause damaged. Slide the locking pin through the hole in the side of the spindle support (#6) and through the spindle. Install the blade, then remove the locking pin.

**WARNING: Make sure the pin is removed prior to engaging the drill.**

## OPERATION

### **Using the pipe notcher fixture.**

1. Insert the tubing you wish to cut in the clamp assembly (#1), underneath the inverted "V". The inverted "V" feature of the clamp will hold your tubing (up to 2" long) in place. Do not insert the tubing more than half of its length. When cutting in severe angles, only insert the tubing far enough to start the cut. Secure the tubing in place using the handle/clamp screw assembly (#2).
2. Set the speed of your drill press to approximately 500 rpm for most materials. When

cutting thin wall, hard alloy tubing such as chrome-moly, higher speeds will be required, when cutting softer, coarser material, slower speeds may be ideal.

*SUGGESTION: Practice on scrap material before making cuts on your work material.*

3. As you work, lubricate both the hole saw and the bushings with cutting oil to extend service life.
4. When doing severe angle cuts with large diameter tubing, you will need to put the spindle support in its uppermost position in order to accommodate its size. However, you should always position the spindle support as low as possible to preserve accuracy. To move the spindle support, simply loosen the two bolts (#16) that affix it to the body, reposition, and secure the bolts.
5. To adjust the angle of the clamp, loosen the bolts (#15) that secure it to the body, reposition to the angle you desire according to the angle indicator (#10), and retighten the bolts.
6. When the tube is clamped in the notcher and the angle is properly set, you can proceed to cut the workpiece.
7. To remove the blade or bit, shut off the drill press, insert the locking pin into the spindle support, and remove the bit.

## MAINTENANCE

**Please observe goods shop practices for your safety and to extend the work life of your tools.**

1. Periodically brush away cuttings and debris from the notcher, especially the bushings and spindle area to avoid scoring or binding these components.
2. Use a suitable light grease on bushings to prevent overheating and wear.
3. When cuttings from the metal tubes, use plenty of cutting fluid to prevent tool or material overheating, and to remove cuttings from the work area.
4. Be sure to carefully align the drill press spindle and the pipe notcher spindle to prevent binding.
5. After use, clean the tube notcher, and apply a light lubrication to all moving parts and unpainted metal to prevent rust.
6. Leave the locking pin in place in the spindle support when moving or storing this fixture.
7. Store the notcher covered and in a dry, dust free place.
8. Help avoid injury by preventing access to this tool by unauthorized persons and children.

TUBING NOTCHER PARTS LIST
---------------------------

Part No.	Description	Qty.	Part No.	Description	Qty.
1	Clamp assembly	1	10	Angle indicator	1
2	Handle/clamp screw	1	11	M8 nut	2
3	5/8" Hole saw adapter washer	1	12	M8 washer	9
4	5/8" Hole saw adapter	2	13	Body	1
5	Bushing	2	14	Locking pin	1
6	Spindle support	1	15	M8x16 bolt	3
7	Spindle	1	16	M8x20bolt	4
8	Rivet	4	17	Adjustable angle joint plate	1
9	Label	1	18	Angle indicator	1

**PLEASE READ THE FOLLOWING CAREFULLY**

THE MANUFACTURER AND /OR DISTRIBUTOR HAS PROVIDED THE PARTS DIAGRAM IN THIS MANUAL AS A REFERENCE TOOL ONLY: NEITHER THE MANUFACTURER NOR DISTRIBUTOR MAKES ANY REPRESENTATION OR WARRANTY OF ANY KIND TO THE BUYER THAT HE OR SHE IS QUALIFIED TO MAKE ANY REPAIRS TO THE PRODUCT OR THAT HE OR SHE IS QUALIFIED TO REPLACE ANY PARTS OF THE PRODUCT: IN FACT THE MANUFACTURER AND / OR DISTRIBUTOR EXPRESSLY STATES THAT ALL REPAIRS AND PARTS REPLACEMENTS SHOULD BE UNDERTAKEN BY CERTIFIED AND LICENSED TECHNICIANS AND NOT BY THE BUYER. THE BUYER ASSUMES ALL RISK AND LIABILITY ARISING OUT OF HIS OR HER REPAIRS TO THE ORIGINAL PRODUCT OR REPLACEMENT PARTS THERETO OR ARISING OUT OF HIS OR HER INSTALLATION OF REPLACEMENT PARTS THERETO.

**TUBING NOTCHER PARTS DIAGRAM**

Please refer to the parts list on previous page.

**TUBING NOTCHER PARTS DIAGRAM**  
*Please refer to the parts list on previous page*

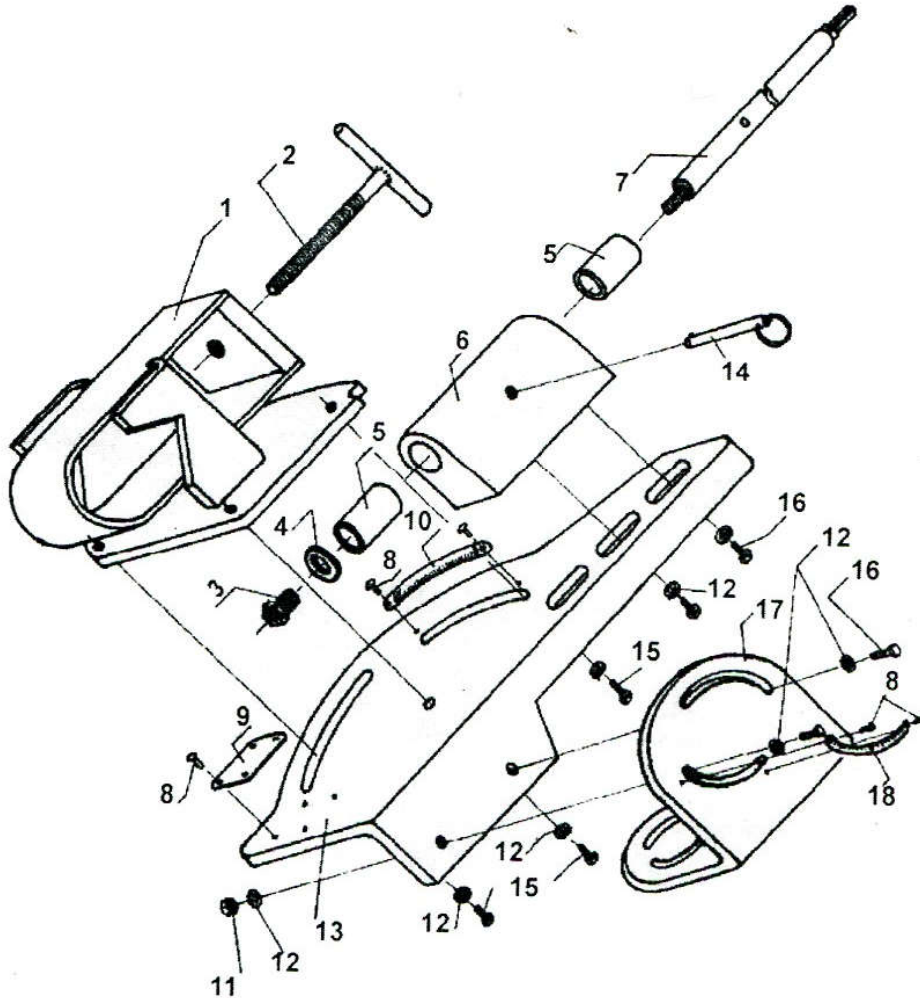

**Note:** This manual is only for your reference. Owing to the continuous improvement of the machine, changes may be made at any time without obligation on notice.