

PAN & BOX BRAKE

PBB-4014A

PBB-5014A



Operation manuals

Specification:

Model	Working length	Sheet thickness	Max. clamping bar lift	Folding angle Deg.
PBB-4014A	1020mm	2mm	46mm	135°
PBB-5014A	1070mm	2mm	46mm	135°

Assembly and installation

The machine is delivered on a wooden pallet. Lift up the machine from the wooden pallet by means of straps and crane. The support legs of the machine (back of the machine) are enclosed. These must be mounted on the machine in order for the machine to stand on the floor. To make use of the good quality and the precision of the machine, it must be mounted on an even and stable floor, where it can be bolted to the floor through the boltholes in the legs. After unpacking, all rust protected parts must be cleaned with paraffin (manual enclosed) and lubricated with acid-free oil.

Operation

Before use, folding stop no. 7 must be loosened. The clamping pressure is from the factory adjusted to zero in sheet thickness. The required clamping pressure can be adjusted by using the adjusting screws no. 6 until the foot pedal no. 1 can be locked at the locking pedal. The folding beam no. 4 can be adjusted to the required sheet thickness by using the handles no. 8. Lower the folding beam to minimum sheet thickness. Check the distance between sharp nose blade / segments by placing the folding beam in 90°. If bend above 90° is required the folding beam must be lowered 25% additionally. Crowning of the folding beam is carried out by means of the two bolts at the adjusting bolt no. 5.

Angle adjustment

Folding stop no. 7 can be adjusted for the required angle. Make a folding test and adjust the folding stop.

Maintenance

Daily cleaning, and every one hundred working hours all blades and guide ways must be cleaned and suitably lubricated.

Extra accessories

Back gauge, radius nosed blade (for models without segments), angle segments, flat blade (10, 15 and 20 mm) and special lower blade for radius blades.

Other sizes: ask for prices.

1. Foot pedal with locking device
2. Bed beam
3. Segments for clamping beam
4. Folding beam

- 5.Crowning adjustment on the folding beam
- 6.Hand lever for clamping beam pressure
- 7.Bending stop
- 8.Handle for adjustment of the folding beam to the correct sheet thickness
- 9.Counter balance arm

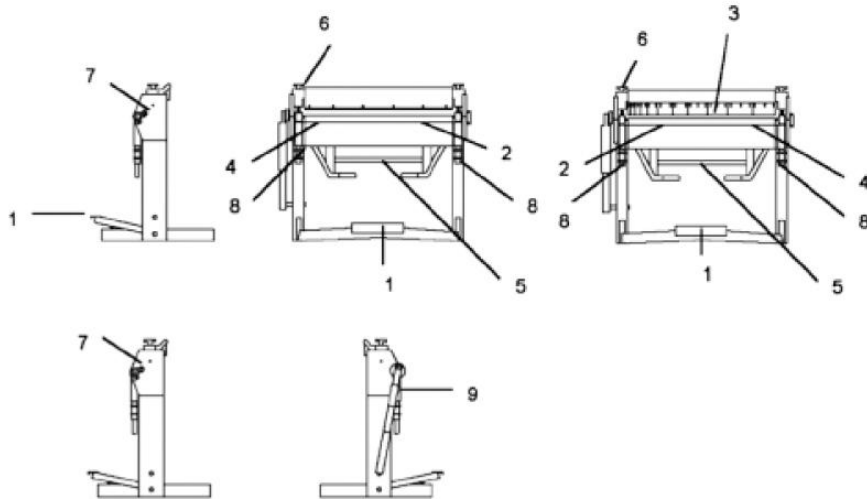

Warning

You have to hold the top of the machine while mounting the support legs.

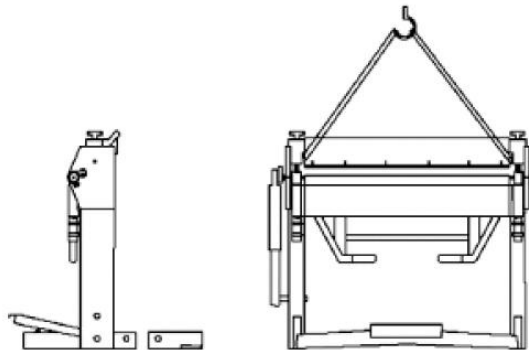

Parts List

Part#	Description	Q'ty	Part#	Description	Q'ty
1	ADJUSTING NUT	2	27	TREAD PLATE RUBBER	1
2	CLAMPING LEAF	1	28	ROLL PIN	2
3	T-NUT M10-1.5	20	29	EXT RETAINING RING 10MM	1
4	UPPER FINGERS	11	30	FOOT PEDAL LOCK	1
5	CAP SCREW M10-1.5 × 20	38	31	SPRING PIN 8 × 50	1
6	CLAMPING BLOCK	1	32	FLAT WASHER 8MM	1
7	ADJUSTING NUT SPRING	2	33	PRDAL LOCK SPRING	1
8	FLAT WASHER 20MM	6	34	LOWER SEGMENT	2
9	GREASE FITTING 8MM	2	35	SPRING PIN 10 × 50	2
10	BUSHING	2	36	SPRING PIN 10 × 50	2
11	FLAT WASHER 30MM	2	37	O-RING 33 × 25	2
12	FOLDING LEAF PIN	1	38	SETBACK KNOB	2
13	CAP SCREW M10-1.5 × 35	1	39	HEX BOLT M8-125 × 15	2
14	STOP COLLAR	1	40	BENDING LEAF	1
15	HEX NUT 10-1.5	1	41	BOLT	2
16	CAP SCREW M10-1.5 × 40	1	42	HEX.BOLTM12-1.75 × 150	2
17	LEG	1	43	STAR WASHER M12	2
18	EXT RETAINING RING 25MM	13	44	LOWER BLADE FITTING	1
19	LEG PIN	3	45	BOTTOM TELESCOPING STRUT	1
20	CAP SCREW M10-1.5 × 30	4	46	SPIRAL BLOCK	1
21	EXTENSION BRACKET	2	47	SPRING	1
22	DISC SPRING 40 × 20 × 1 × 2.4	4	48	TOP TELESCOPING STRUT	1
23	ROD	2	49	BUSHING	1
24	FOOT PEDAL LEVER	4	50	SHIM RING	1
25	LEVER PIN	4	51	CRANK	2
26	FOOT PEDAL	1			

