

Aluminum Spiral Duct Mounted Grille Single or Double Deflection • Optional Damper/Extractor

Model: US301FL • Universal Endcaps • Single Deflection • Long Blades • $\frac{3}{4}$ " Blade Spacing
US301FS • Universal Endcaps • Single Deflection • Short Blades • $\frac{3}{4}$ " Blade Spacing
US300FL • Universal Endcaps • Double Deflection • Long Front Blades • $\frac{3}{4}$ " Blade Spacing
US300FS • Universal Endcaps • Double Deflection • Short Front Blades • $\frac{3}{4}$ " Blade Spacing

Single Deflection Models: US301FL or US301FS

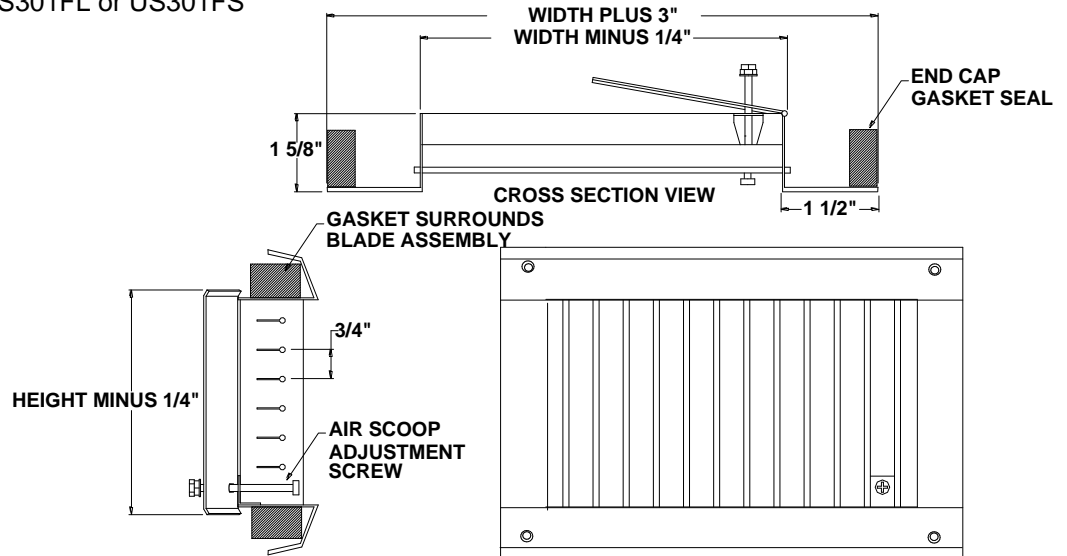

Dimensions are in inches

Double Deflection Models: US300FL or US300FS

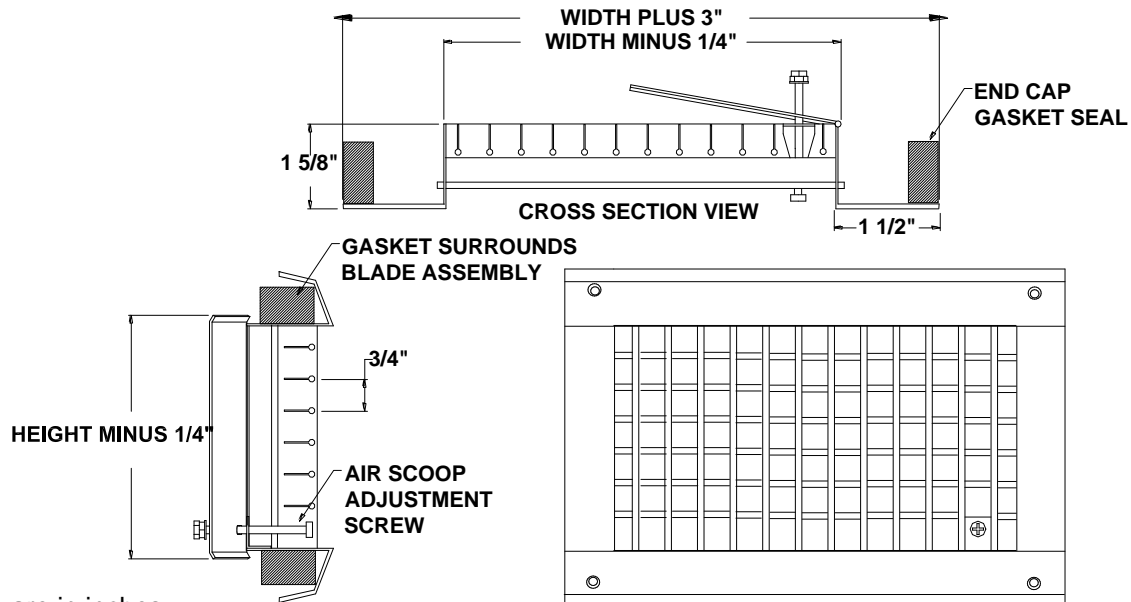

Dimensions are in inches

Available Duct Diameter by Height

Height	3"	4"	6"	8"	10"	12"
Min : Max Duct Diameter	10" : 36"	10" : 36"	12" : 36"	20" : 36"	24" : 36"	24" : 36"

Typical Installation

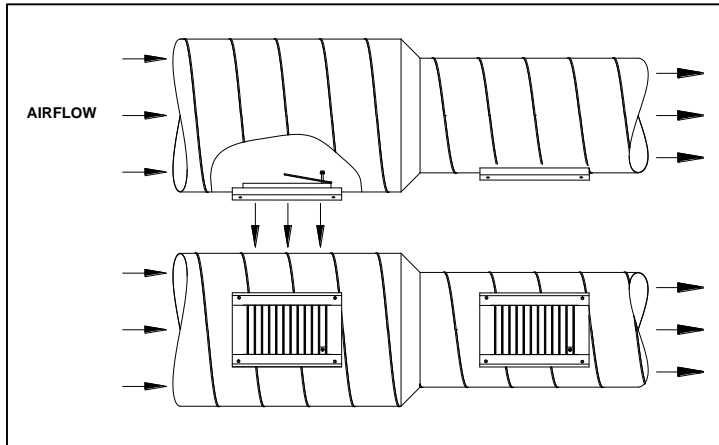

Standard Finish: #26 White

Optional Extractor:

Model ASD - Air Scoop Device. Extractor must be ordered with grille. Cannot be field installed.

Application Notes:

For duct velocities up to 800 fpm, the extractor is not required. For duct velocities higher than 800 fpm, the extractor is recommended.

General Description

- Spiral Grilles save contractor installation time and money by directly mounting to the duct.
- Available with single or double deflection, with adjustable louvers vertical or horizontal.
- Front louvers available in vertical or horizontal.
- All-aluminum construction with universal end caps to match duct diameters from 10" thru 36" in even increments.
- Foam gasketing standard for tight seal to duct.
- Optional ASD (Air Scoop Device) - operable with Phillips screwdriver for volume adjustment, accessible from grille face.

This submittal is meant to demonstrate general dimensions of this product. The drawings are not meant to detail every aspect of the product. Drawings are not to scale. Titus reserves the right to make changes without written notice.

All rights reserved. No part of this work may be reproduced or transmitted in any form or by any means, electronic or mechanical, including photocopying and recording, or by any information storage retrieval system without permission in writing from Air Distribution Technologies.