

DUCT TRAPEZE

Single channel Gripple fastener with integral bracket for use with No.2 Gripple hangers:



Size:
No.2

Max. Safe Working Load:
No.2 100 lbs

FUNCTION:

The suspension of rectangular ductwork, fan coil units, and other suitable services in an indoor stationary setting. NOT suitable for use in chlorinated / swimming pool environments.

APPLICATION:

Attaches to service at three points with self-tapping screws. Comes in a kit with cable and choice of pre-attached end fixing.

LOAD RATING:

All Duct Trapeze products have a 5:1 safety factor.

MATERIAL SPECIFICATION:

Duct Trapeze Fastener:	Housing	Type ZA2 Zinc
	Wedge	Sintered steel hardened to min. 56 Rockwell C
	Spring	Stainless Steel (Type 302)
	End Cap	UV stabilized homopolymer polypropylene
	Optional Rubber Pad	EPDM 40 +/- 5 SHORE A

Cable:

Galvanized high tensile steel cable to EN12385.
Standard lengths from 5ft-30ft, other lengths can be made to order.

No.2	
Cable Diameter (in.)	5/64
Strand configuration	1x19
Min. breaking load (lbs)	500
Max. safe working load (lbs)	100
Tensile strength (lbs/sq. in.)	256,700

Size Specs

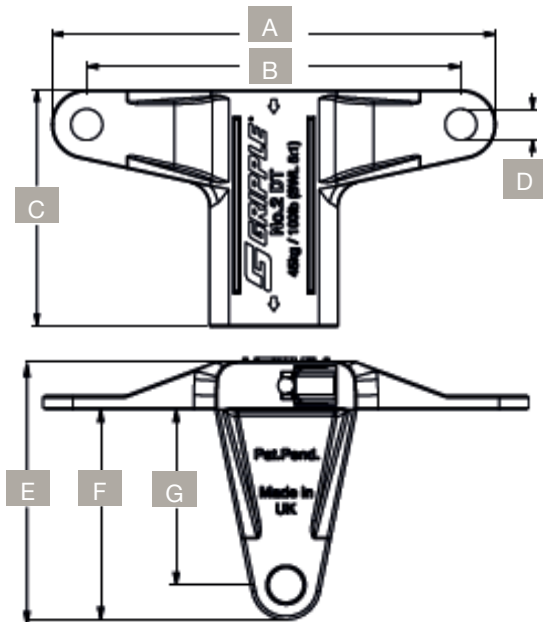

Dimension	Inches	Dimension	Inches
A	2 3/4"	E	1 1/2"
B	2 3/8"	F	1 7/32"
C	1 1/2"	G	1"
D	Ø 13/64"		

Application Examples



HVAC or mechanical services (single tier)



HVAC or mechanical services (double tier)