



## REC-ZCF3-30

Powerful and flexible filtration

# REC-ZCF3-30



## Plug and play filtering

The REC-ZCF combo skid offers a popular module combination in a plug-and-play unit that is pre-piped and wired, ready for connection to tanks and wash process. The REC/ZCF Skid is a powerful and flexible pumping and filtration system that can serve as the hub of a wide range of treatment system processes. All features of REC and ZCF are retained without modifications in the REC/ZCF Skid system.



### 1 Filter heads incorporate programmable smart electronics

■ ZCF filter controller is equipped with a backlit display, plain-English menu-driven program customizability, water management versatility, data-logging, filter performance pressure monitor.

### 2 Fundamental to the water treatment process

■ Waste water pumping and particulate filtration are two processes that are fundamental to treating waste streams generated by commercial washing operations and light industrial applications. The REC and ZCF enable automatic water management, water recycling and even discharge to sanitary sewer where codes allow.

### 3 Customize and Accessorize

■ Accessories enhance the effectiveness of Industrial Wastewater Treatment Systems. Water Maze offers a broad selection of add-ons, accessories, parts, and consumables that support the performance of your water treatment systems.

### 4 Detergents, Media and Consumables

■ Water Maze offers a variety of additives, defoamers and detergents to enhance the effectiveness of water treatment systems. We have a line of quick-release detergents available in 5 and 55 gallons. Filter media such as sand, gravel, and clay, which help provide separation of contaminants in water filtration equipment. We also offer bio-pucks and biostax products for our bioremediation systems, that are designed to alleviate odor in collection pits.

# TECHNICAL DATA AND EQUIPMENT

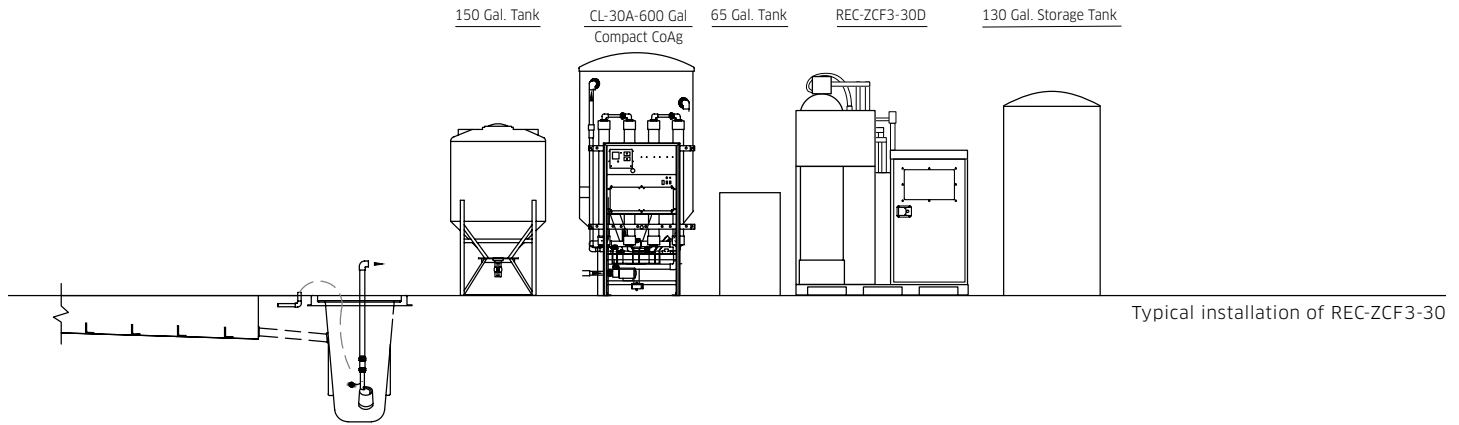

Typical installation of REC-ZCF3-30

## Features

- Water Management module REC3-30A & ZCF2-30D Filtration module - incorporated onto one skid
- Pre-plumbed interconnecting PVC piping and fittings between each module
- Configured onto a single stainless steel skid with painted carbon steel enclosure with lockable front door
- Steel components are protected with powder coated finish
- 1.5 HP self-priming pump - transfer rate up to 30 GPM and up to 40 PSI
- 2 HP self-priming pump (optional) - transfer rate up to 40 GPM and up to 40 PSI
- Easy access to components (pump, piping, and electrical)
- Certifications - UL73
- Small footprint: 70" x 49" x 81"

## Technical data

Model	Part No.	Description	Flow GPM	Voltage	Phase	AMPS	Est. Ship Weight (lbs.)
REC-ZCF3-30	1.103-513.0	Pumping & Filtration System	Up to 30	230	1	20	2,000
REC-ZCF3-30 Special	Special	REC-ZCF3-30 with 2 HP Self-priming pump	Up to 40	230	1	20	2,000

## Stand Alone Equipment

ZCF2-30D	1.103-512.0	Automatic Filtration System Only	Up to 20	120	-	1	1,450
REC3-30A	1.103-511.0	Water Management Pumping System	Up to 30	230	1	20	525
REC3-30A Special	Special	ZCF3-30 with 2 HP Self-priming pump	Up to 40	230	1	22	525

### Equipment Dimensions (approximate)

REC-ZCF Physical: 70" x 49" x 81" Shipping: 84" x 56" x 86" Estimated product tare weight: 1,726 lbs.  
 ZCF Physical: 46" x 34" x 81" Shipping: 66" x 53" x 86" Estimated product tare weight: 1,250 lbs.  
 REC Physical: 38" x 31" x 53" Shipping: 58" x 41" x 66" Estimated product tare weight: 325 lbs.

## Optional Accessories

Part No.	Description
8.928-603.0	Ozone Generator Kit for REC3-30A

NOTE: Each media housing includes 50 lbs of Gravel, 75 lbs of Garnet, and 250 lbs of Zeolite Media



Standard Water Maze System for filtration and recycle

Contact us for more information:

**Water Maze**

4555 Airport Way  
Denver, CO 80239  
U.S.A.

Tel. 800-347-6116  
Fax. 800-535-9164

[info@wmaze.com](mailto:info@wmaze.com)

[www.wmaze.com](http://www.wmaze.com)  
[dealer.wmaze.com](http://dealer.wmaze.com)