

# LANDA®

# PG

Kärcher Group

# OPERATOR'S MANUAL

■ PG4-2000

■ PG4-3500

■ PG4-4000E

■ PG5-3500E

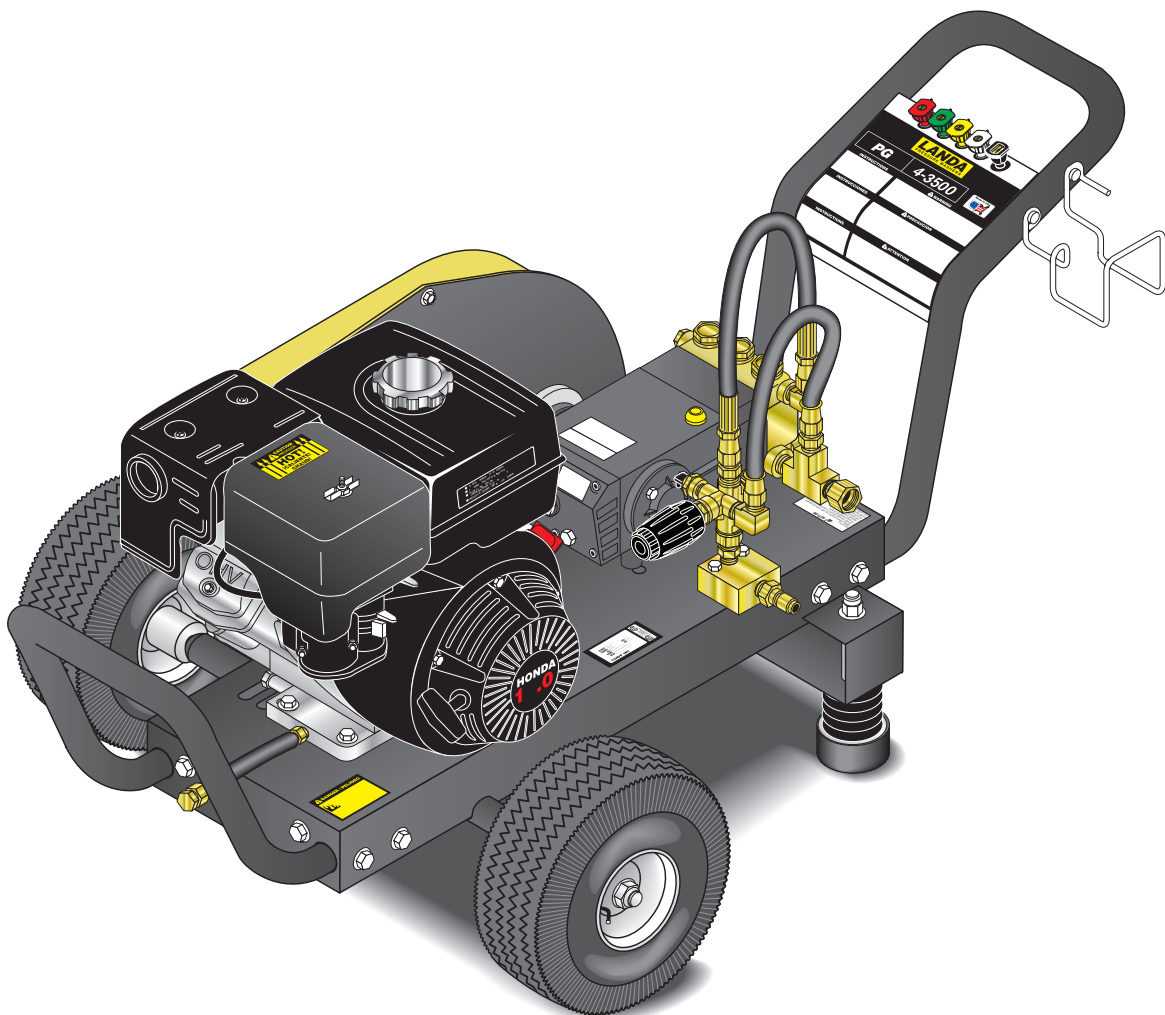

For technical assistance or the dealer nearest you,  
consult our web page at [www.landa.com](http://www.landa.com)

8.913-910.0



# CONTENTS

Introduction & Important Safety Information	4-5
Component Identification 4-2000, 4-3500	6
Component Identification 4-4000, 5-3500	7
Assembly Instructions	8
Operation Instructions	9
Detergents & General Cleaning Techniques	10
ShutDown Instructions	11
Storage	11
Troubleshooting	12-13
Preventative Maintenance & Oil Change Charts	14
Options	15
Exploded Views, 4-2000, 4-3500	16-17
Exploded Views, 4-2000, 4-3500 Parts List	18-19
Exploded View, 4-4000, 5-3500	20-21
Exploded View, 4-4000, 5-3500 Parts List	22-23
Hose & Spray Gun Assembly & Parts List	24
Downstream Injector & Parts List	25
Specifications	26-27
Pump Exploded View and Parts List	28-29
Unloader Exploded View and Parts List	30

Model Number \_\_\_\_\_

Serial Number \_\_\_\_\_

Date of Purchase \_\_\_\_\_

The model and serial numbers will be found on a decal attached to the pressure washer. You should record both serial number and date of purchase and keep in a safe place for future reference.

# INTRODUCTION & IMPORTANT SAFETY INFORMATION

Thank you for purchasing this Pressure Washer. We reserve the right to make changes at any time without incurring any obligation.

## Owner/User Responsibility:

The owner and/or user must have an understanding of the manufacturer's operating instructions and warnings before using this pressure washer. Warning information should be emphasized and understood. If the operator is not fluent in English, the manufacturer's instructions and warnings shall be read to and discussed with the operator in the operator's native language by the purchaser/owner, making sure that the operator comprehends its contents.

Owner and/or user must study and maintain for future reference the manufacturers' instructions.

The operator must know how to stop the machine quickly and understand the operation of all controls. Never permit anyone to operate the engine without proper instructions.

## SAVE THESE INSTRUCTIONS

This manual should be considered a permanent part of the machine and should remain with it if machine is resold.

When ordering parts, please specify model and serial number. Use only identical replacement parts.

This machine is to be used only by trained operators.

## IMPORTANT SAFETY INFORMATION

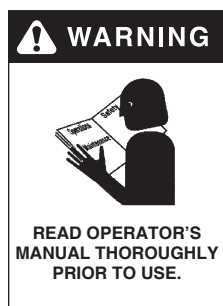

**WARNING: To reduce the risk of injury, read operating instructions carefully before using.**

1. Read the owner's manual thoroughly. Failure to follow instructions could cause malfunction of the machine and result in death, serious bodily injury and/or property damage.
2. Know how to stop the machine and bleed pressure quickly. Be thoroughly familiar with the controls.
3. Stay alert — watch what you are doing.
4. All installations must comply with local codes. Contact your electrician, plumber, utility company or the selling distributor for specific details.



**WARNING: Risk of asphyxiation. Use this product only in a well ventilated area.**

5. Avoid installing machines in small areas or near exhaust fans. Exhaust contains poisonous carbon monoxide gas; exposure may cause loss of consciousness and may lead to death. It also contains

chemicals known, in certain quantities, to cause cancer, birth defects or other reproductive harm.



**WARNING: Risk of fire. Do not add fuel when the product is operating.**

**WARNING: Risk of explosion — do not spray flammable liquids.**

6. Do not place machine near flammable objects as the engine is hot.

**WARNING: This product contains chemicals known to the state of California to cause cancer and birth defects or other reproductive harm. Operation of this equipment may create sparks that can start fires around dry vegetation. A spark arrestor may be required. The operator should contact: Local fire agencies for laws or regulations relating to fire prevention requirements.**

7. Allow engine to cool for 1-2 minutes before refueling. If any fuel is spilled, make sure the area is dry before testing the spark plug or starting the engine. (Fire and/or explosion may occur if this is not done.)

Gasoline engines on mobile or portable equipment shall be refueled:

- a. outdoors;
- b. with the engine on the equipment stopped;
- c. with no source of ignition within 10 feet of the dispensing point; and
- d. with an allowance made for expansion of the fuel should the equipment be exposed to a higher ambient temperature.

In an overfilling situation, additional precautions are necessary to ensure that the situation is handled in a safe manner.

**WARNING: Risk of injury. Disconnect battery ground terminal before servicing.**

8. Transport/repair with fuel tank EMPTY or with fuel shut-off valve OFF.

# IMPORTANT SAFETY INFORMATION



**WARNING:** Keep wand, hose, and water spray away from electric wiring or fatal electric shock may result.

- Do not spray water on or near electrical components.



**WARNING:** High pressure developed by these machines will cause personal injury or equipment damage. Keep clear of nozzle. Use caution when operating. Do not direct discharge stream at people, or severe injury or death will result.

- Never make adjustments on machine while in operation.
- Be certain all quick coupler fittings are secured before using pressure washer.



**WARNING:** Flammable liquids can create fumes which can ignite, causing property damage or severe injury.

**WARNING:** Risk of explosion — Do not spray flammable liquids.

- Keep operating area clear of

all persons.



**WARNING:** Protect machine from freezing.

- To keep machine in best operating conditions, it is important you protect machine from freezing. Failure to protect machine from freezing could cause malfunction of the machine and result in death,

serious bodily injury, and/or property damage. Follow storage instructions specified in this manual.

- The best insurance against an accident is precaution and knowledge of the machine.



**WARNING:** This machine exceeds 85 db appropriate ear protection must be worn.



**WARNING:** Be extremely careful when using a ladder, scaffolding or any other relatively unstable location. The cleaning area should have adequate slopes and drainage to reduce the possibility of a fall due to slippery surfaces.



**WARNING:** High pressure spray can cause paint chips or other particles to become airborne and fly at high speeds. To avoid personal injury, eye, hand and foot safety devices must be worn.

- Eye, hand, and foot protection must be worn when using this equipment.

- Do not overreach or stand on unstable support. Keep good footing and balance at all times.

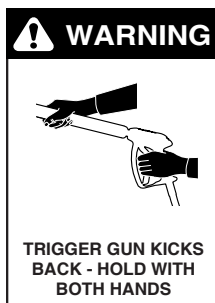

**WARNING:** Grip cleaning wand securely with both hands before starting. Failure to do this could result in injury from a whipping wand.

- To reduce the risk of injury, close supervision is necessary when a machine is used near children. Do not allow children

to operate the pressure washer. **This machine must be attended during operation.**

- Do not operate this machine when fatigued or under the influence of alcohol, prescription medications, or drugs.

- Inlet water must be clean fresh water and no hotter than 90°F.

- Manufacturer will not be liable for any changes made to our standard machines or any components not purchased from us.

- Do not allow acids, caustic or abrasive fluids to pass through the pump.

- Never run pump dry or leave spray gun closed longer than 1-2 minutes.



**Follow the maintenance instructions specified in the manual.**

# COMPONENT IDENTIFICATION - 4-2000, 4-3500

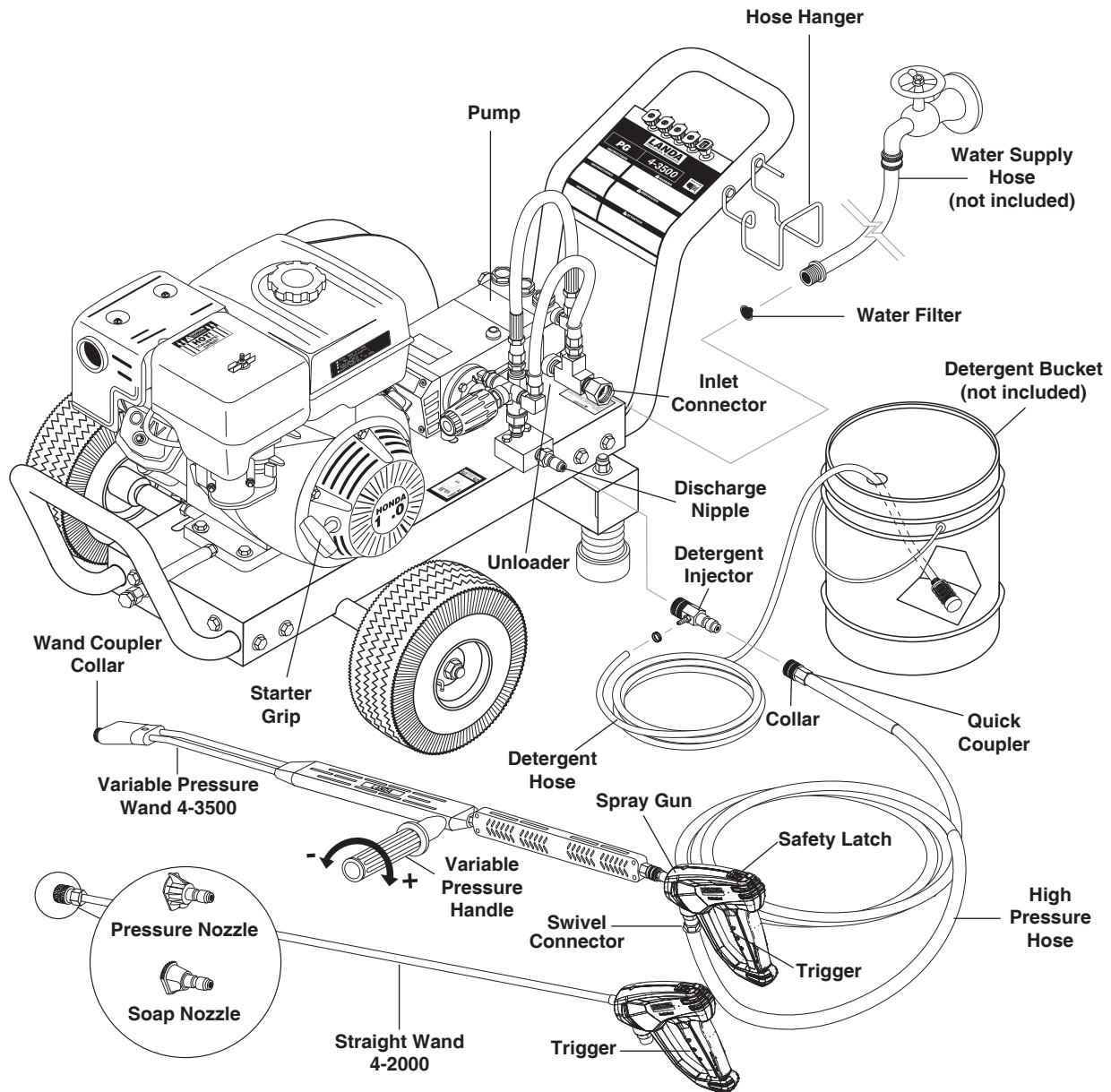

**Pump** — Develops high pressure.

**Starter Grip** — Used for starting the engine manually.

**Spray Gun** — Controls the application of water and detergent onto cleaning surface with trigger device. Includes safety latch.

**Detergent Injector** — Allows you to siphon and mix detergents.

**Variable Pressure Wand** — Must be connected to the spray gun. Allows for detergent injection and lower pressure by turning handle.

**High Pressure Hose** — Connect one end to water pump discharge nipple and the other end to spray gun.

**Pump Protector** — Cycles water through pump when water reaches 140°-145°F.

**Note:** If trigger on spray gun is released for more than 1-2 minutes, water will leak from valve. Warm water will discharge from pump onto floor. This system prevents internal pump damage.

# COMPONENT IDENTIFICATION - 4-4000, 5-3500

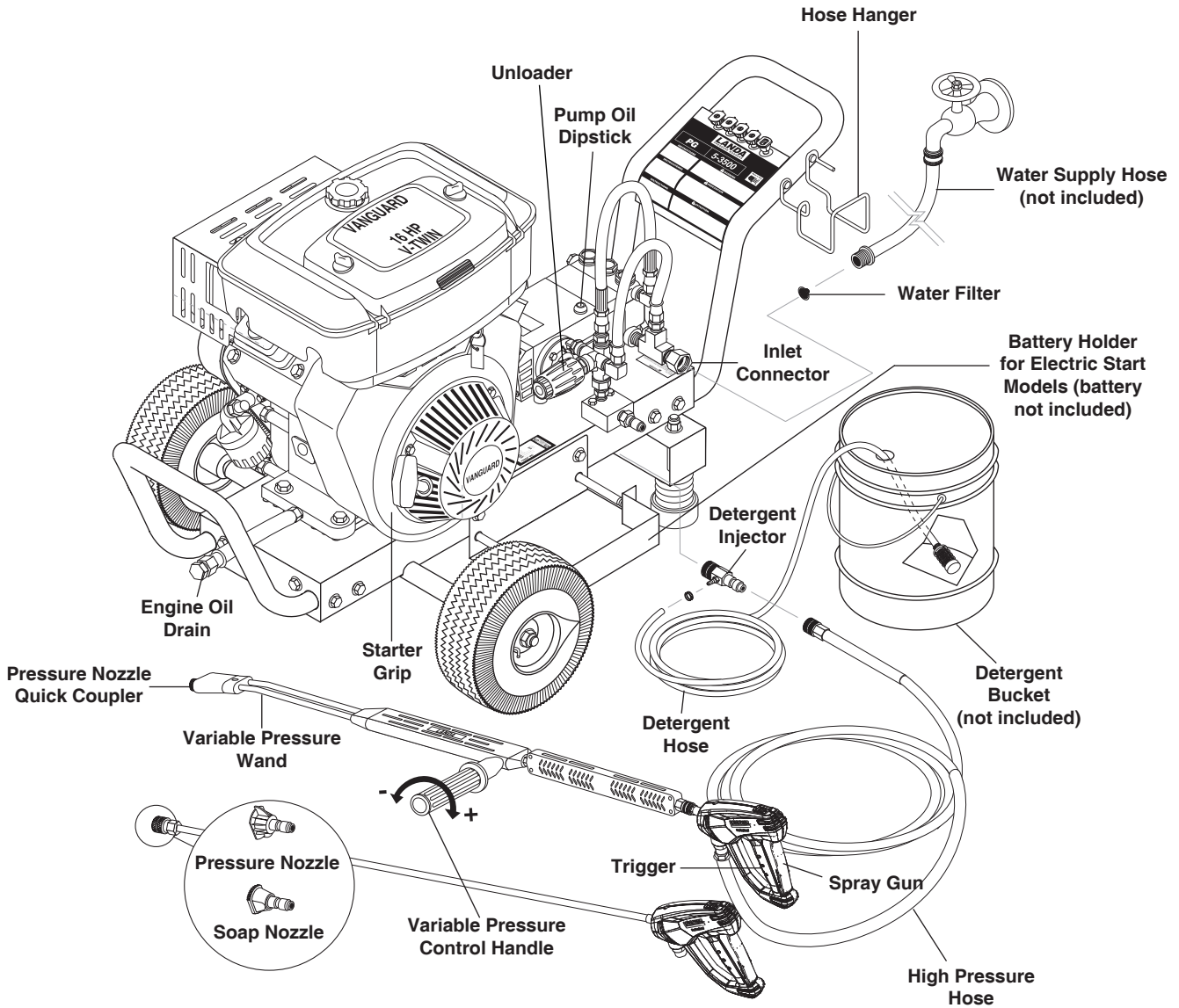

# ASSEMBLY INSTRUCTIONS

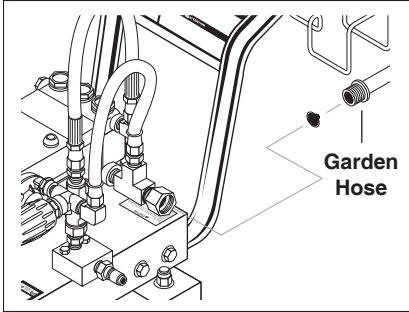

**STEP 1:** Attach a 5/8" garden hose to inlet connector. Minimum flow should be 6 gpm.

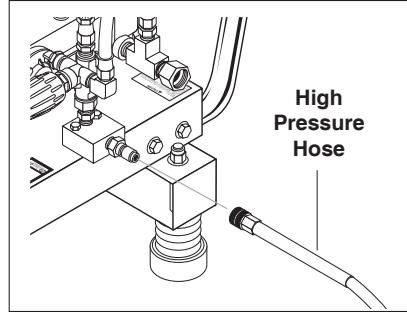

**STEP 2:** Attach high pressure hose to discharge nipple using quick coupler. Lock coupler securely into place by pulling back coupler collar and inserting it onto discharge nipple, then pushing collar forward to lock in place.

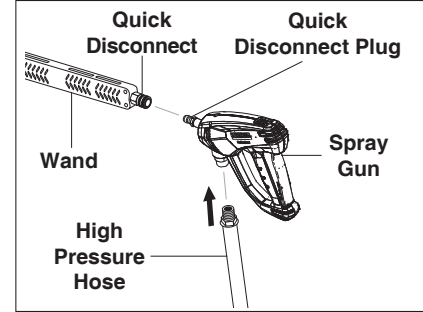

**STEP 3:** Attach wand to spray gun using quick disconnect. Attach swivel connector on discharge hose to spray gun using teflon tape on threads. Attach swivel connector on high pressure hose to spray gun using teflon tape on threads. Engage safety latch to prevent from triggering gun.

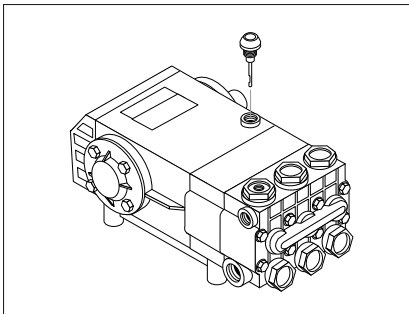

**STEP 4:** Remove oil plug on top of pressure washer pump and replace with dipstick supplied. (This may be installed from the factory.)

Check oil level on sight glass on back of pump. Oil should be visible one half way up sight glass (30W non-detergent).

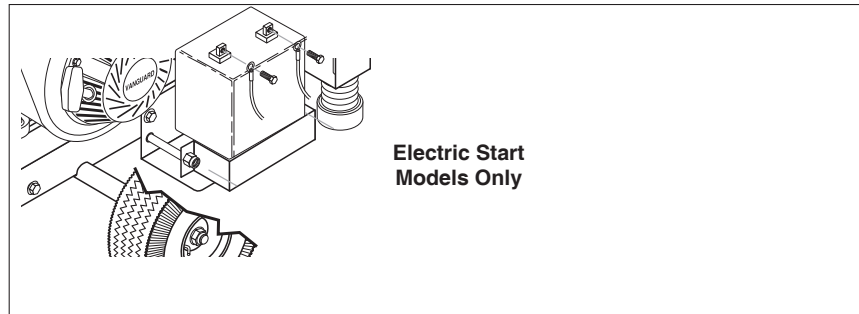

**STEP 5:** Use a group U1, 12 volt, 30 amp hour battery (garden tractor battery). Secure U1 battery to the battery holder using the battery clamp provided.

To reduce the possibility of sparking attach the battery cables in the following order. First attach the positive battery cable (red) to the positive "+" terminal of battery. Next, attach the negative battery cable (black) to the negative "-" terminal of the battery. To disconnect the battery remove the cables in the opposite order as installed.

**WARNING:** Wear eye, hand and skin protection when handling or connecting battery.

**WARNING:** Batteries generate explosive gases during normal battery operation. DO NOT expose the battery to flame or sparks as these gases may ignite.

**WARNING:** Battery fluid is highly acidic. If battery fluid contacts skin or clothing, wash immediately with soap and water. If battery fluid enters eye, immediately flood eye with running cold water for at least 15 minutes and get immediate medical attention.

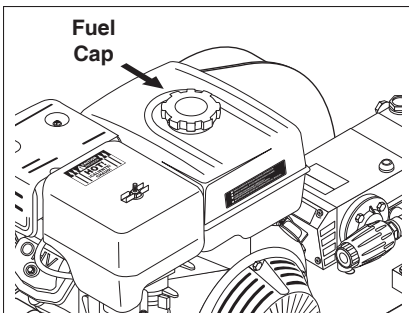

**STEP 6:** Fill gasoline tank and check engine oil.

**Notice:** Running the engine with a low oil level can cause engine damage.

**NOTE:** The battery must be capable of accepting ring terminals.

**NOTE:** Battery and battery cable mounting bolts and nuts are not provided.



# OPERATION INSTRUCTIONS

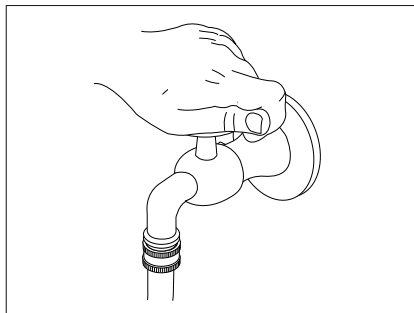

**STEP 1:** Turn on water at faucet and squeeze spray gun trigger allowing water to flow until a steady stream comes out of wand. Then install nozzle

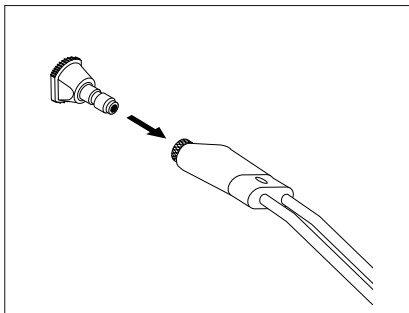

**STEP 2:** Read engine manual warning and operating instructions.

Pull wand coupler collar back and insert pressure nozzle into coupler then secure by pushing collar forward to lock.

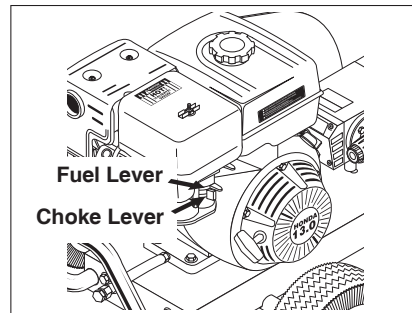

**STEP 3:** Move the fuel valve lever to the ON position.

To start a cold engine, move the choke lever to the CLOSED position. To restart a warm engine, leave the choke lever in the OPEN position.

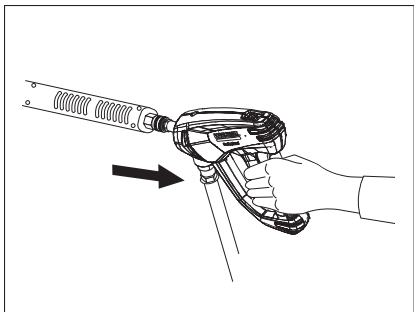

**STEP 4:** Open spray gun before pulling the starter grip.

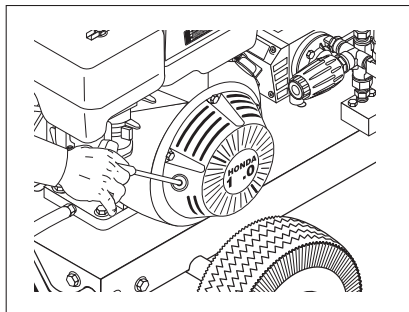

**STEP 5:** To start the engine pull the starter grip lightly until you feel resistance, then pull briskly. Return the starter grip gently.

**CAUTION:** Pull trigger on spray gun to relieve pressure if machine does not start after one pull of starter grip.

**CAUTION:** Small engines may kick back. Do not hold starter grip tightly in hand.

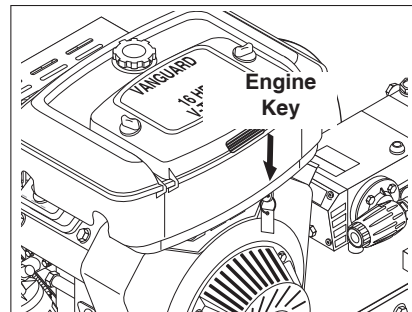

**STEP 6: On models with electric start:** Turn the key to the START position and hold it there until the engine starts. If the engine fails to start within 5 seconds, release the key and wait at least 10 seconds before operating the starter again.

**NOTICE:** Using the electric starter for more than 5 seconds at a time will overheat the starter motor and can damage it. When the engine starts, release the key, allowing it to return to the ON position.

# DETERGENTS AND GENERAL OPERATING TECHNIQUES

## WARNING



**WARNING:** Some detergents may be harmful if inhaled or ingested, causing severe nausea, fainting or poisoning. The harmful elements may cause property damage or severe injury.

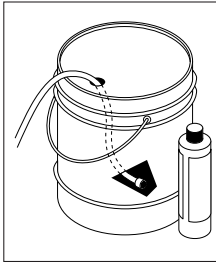

**STEP 1:** Use detergent designed specifically for pressure washers. Household detergents could damage the pump. Prepare detergent solution as required by the manufacturer. Fill a container with pressure washer detergent. Place the filter end of detergent suction tube into the detergent container.

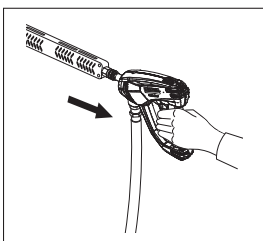
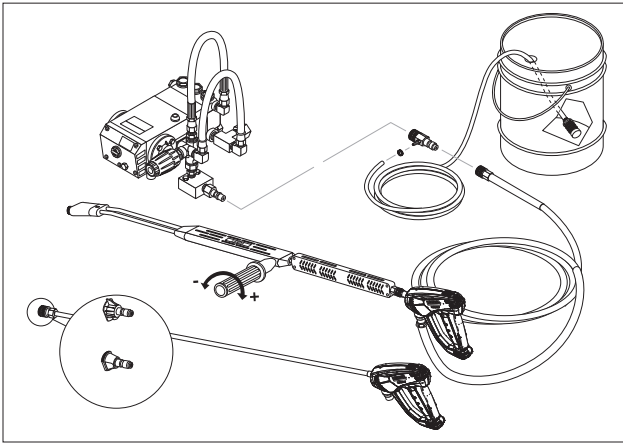

**STEP 2:** Apply safety latch to spray gun trigger. Secure black detergent nozzle into quick coupler. **NOTE:** Detergent cannot be applied using the yellow nozzle.

**STEP 3:** With the motor running, pull trigger to operate machine. Liquid detergent is drawn into the machine and mixed with water. Apply detergent to work area. Do not allow detergent to dry on surface.

**IMPORTANT:** You must flush the detergent injection system after each use by placing the suction tube into a bucket of clean water, then run the pressure washer in low pressure for 1-2 minutes.

## THERMAL PUMP PROTECTION

If you run your pressure washer for 1-2 minutes without pressing the trigger on the spray gun, circulating water in the pump can reach high temperatures. When the

water reaches this temperature, the pump protector engages and cools the pump by discharging the warm water onto the ground. This thermal device prevents internal damage to the pump.

## CLEANING TIPS

Pre-rinse cleaning surface with fresh water. Place detergent suction tube directly into cleaning solution and apply to surface at low pressure (for best results, limit your work area to sections approximately 6 feet square and always apply detergent from bottom to top). Allow detergent to remain on surface 1-3 minutes. Do not allow detergent to dry on surface. If surface appears to be drying, simply wet down surface with fresh water. If needed, use brush to remove stubborn dirt. Rinse at high pressure from top to bottom in an even sweeping motion keeping the spray nozzle approximately 1 foot from cleaning surface. Use overlapping strokes as you clean and rinse any surface. For best surface cleaning action spray at a slight angle.

## Recommendations:

- Before cleaning any surface, an inconspicuous area should be cleaned to test spray pattern and distance for maximum cleaning results.
- If painted surfaces are peeling or chipping, use extreme caution as pressure washer may remove the loose paint from the surface.
- Keep the spray nozzle a safe distance from the surface you plan to clean. High pressure wash a small area, then check the surface for damage. If no damage is found, continue to pressure washing.

### CAUTION - Never use:

- Bleach, chlorine products and other corrosive chemicals
- Liquids containing solvents (i.e., paint thinner, gasoline, oils)
- Tri-sodium phosphate products
- Ammonia products
- Acid-based products

These chemicals will harm the machine and will damage the surface being cleaned.

## RINSING

It will take a few seconds for the detergent to clear. Apply safety latch to spray gun. Remove black soap nozzle from the quick coupler. Select and install the desired high pressure nozzle. **NOTE:** You can also stop detergent from flowing by simply removing detergent siphon tube from bottle.

## SHUTDOWN INSTRUCTIONS

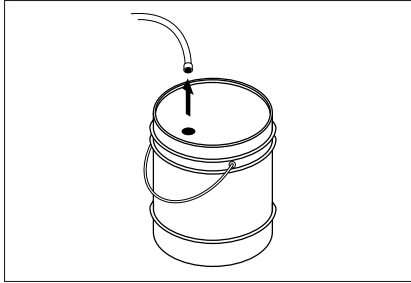

**STEP 1:** Remove detergent suction tube from container and insert into one (1) gallon of fresh water. Pull trigger on spray gun and siphon water for one minute.

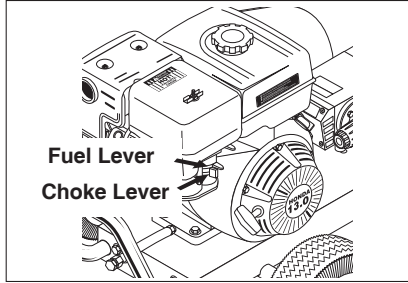

**STEP 2:** Turn off engine.

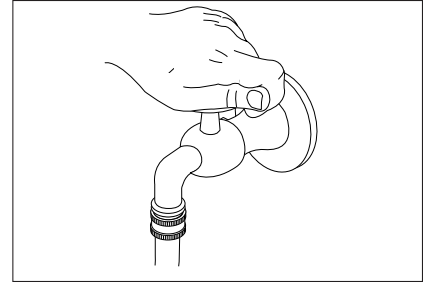

**STEP 3:** Turn off water supply and disconnect water supply hose from washer. **CAUTION:** Do not allow pump to run without water.

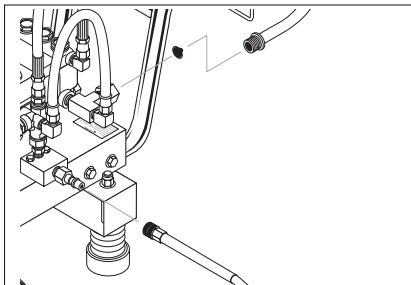

**STEP 4:** Disconnect all hoses to allow water to drain. Protect from freezing.

## STORAGE

**CAUTION:** Always store your pressure washer in a location where the temperature will not fall below 32°F (0°C). The pump in this machine is susceptible to permanent damage if frozen. **FREEZE DAMAGE IS NOT COVERED BY WARRANTY.**

1. Stop the pressure washer, squeeze spray gun trigger to release pressure.
2. Detach water supply hose and high pressure hose.
3. Turn on the machine for a few seconds, until remaining water exits. Turn engine off immediately.
4. Drain the gas and oil from the engine.
5. Do not allow high pressure hose to become kinked.
6. Store the machine and accessories in a room which does not reach freezing temperatures.

**CAUTION:** Failure to follow the above directions will result in damage to your pressure washer.

When the pressure washer is not being operated or is being stored for more than one month, follow these instructions:

1. Replenish engine oil to upper level.
2. Drain gasoline from fuel tank, fuel line, fuel valve and carburetor.
3. Pour about one teaspoon of engine oil through the spark plug hole, pull the starter grip several times and replace the plug. Then pull the starter grip slowly until you feel increased pressure which indicates the piston is on its compression stroke and

leave it in that position. This closes both the intake and exhaust valves to prevent rusting of cylinder.

4. Cover the pressure washer and store in a clean, dry place that is well ventilated away from open flame or sparks. **NOTE:** The use of a fuel additive, such as STA-BIL®, or an equivalent, will minimize the formulation of fuel deposits during storage. Such additives may be added to the gasoline in the fuel tank of the engine, or to the gasoline in a storage container.

### After Extended Storage

**CAUTION:** Prior to restarting, thaw out any possible ice from pressure washer hoses, spray gun or wand.

### Engine Maintenance

During the winter months, rare atmospheric conditions may develop which will cause an icing condition in the carburetor. If this develops, the engine may run rough, lose power and may stall. This temporary condition can be overcome by deflecting some of the hot air from the engine over the carburetor area. **NOTE:** Refer to the engine manufacturer's manual for service and maintenance of the engine.

## TROUBLESHOOTING

PROBLEM	POSSIBLE CAUSE	SOLUTION
<b>LOW OPERATING PRESSURE</b>	Insufficient water supply. Closed faucet	Use larger garden hose; clean inlet water screen. Open faucet.
	Old, worn or incorrect spray nozzle	Match nozzle number to machine and/or replace with new nozzle.
	Plumbing or hose leak	Check plumbing system for leaks. Re-tape leaks with teflon tape.
	Faulty or mis-adjusted unloader valve	Adjust unloader for proper pressure. Install repair kit when needed. <b>Note:</b> Tampering with the factory setting may cause personal injury and/or property damage, and will void the manufacturer's warranty.
	Worn packing in pump	Call local dealer.
	Machine has been stored in freezing temperatures	Thaw out machine completely, including hose, spray gun and wand.
	Slow engine RPM	Call local dealer.
<b>FLUCTUATING PRESSURE</b>	Worn pump valves	Call local dealer.
	Dirt in pump valves	Call local dealer.
	Pump sucking air	Check all pump lines and connections.
	Gasoline Engine Altitude	The gasoline engine is preset for operation at altitudes below 1000 feet above sea level. If operated at higher altitudes, it may be necessary to install a high altitude main jet in the carburetor. Contact your local authorized engine sales and service center for details
<b>PRESSURE LOW AFTER PERIOD OF NORMAL USE</b>	Nozzle worn	Replace nozzle.
	Unloader valve worn	Replace unloader valve.
<b>ENGINE WILL NOT START OR STOPS WHILE OPERATING</b>	Low oil shutdown	Fill engine with oil.
<b>ENGINE IS OVERLOADED</b>	Nozzle partially blocked	Clean nozzle.
	Excessive pressure from high engine RPM	Adjust engine throttle to lower RPM.
<b>WATER OR OIL LEAKING FROM BOTTOM OF PUMP</b>	A small amount of leaking is normal	If excessive leaking occurs, call local dealer.
<b>PRESSURE INCREASES WHEN SPRAY GUN IS CLOSED</b>	Unloader valve not operating properly	Call local dealer.
<b>PRESENCE OF WATER IN PUMP OIL</b>	Water sprayed at machine	Change oil. Direct spray away from machine.
	High humidity in air	Check and change oil twice as often.
	Piston packing worn. Oil seal worn	Call local dealer.

## TROUBLESHOOTING

PROBLEM	POSSIBLE CAUSE	SOLUTION
<b>OIL SQUIRTS OUT OF OIL CAP ON PUMP</b>	Pump over filled with oil	Maintain oil level at red dot on sight glass at rear of pump or at top of notch on dipstick.
<b>ENGINE OPERATES FOR 15 MIN. THEN STOPS</b>	Not enough gas or engine oil	Fill tank with gas. Check oil level.
	Vapor lock developed by heat of day	Keep gas tank full to avoid vapor locking.
	Obstruction in fuel filter	Clean or replace fuel filter.
<b>WATER DRIPPING FROM UNDER PUMP</b>	Piston packing worn	Call local dealer.
	O-Ring plunger retainer worn	Call local dealer.
	Cracked piston	Call local dealer.
<b>OIL DRIPPING</b>	Oil seal worn	Call local dealer.
<b>WATER LEAKING FROM PUMP PROTECTOR</b>	Spray gun closed with machine running 5 minutes or longer	Open spray gun or turn off machine.
	Excess water supply pressure	Place a pressure regulator at end of 50' garden hose.

## PREVENTATIVE MAINTENANCE

This pressure washer was produced with the best available materials and quality craftsmanship. However, you as the owner have certain responsibilities for the correct care of the equipment. Attention to regular preventative maintenance procedures will assist in preserving the performance of your equipment. Contact your Landa dealer for maintenance. Regular preventative maintenance will add many hours to the life of your pressure washer. Perform maintenance more often under severe conditions.

MAINTENANCE SCHEDULE		
Engine Oil	Inspect	Daily
	Change	First month or 20 hours. Every 100 hours or every 6 months after first month
		Every 25 hours.
		Every 50 hours or monthly
Filter	Every 50 hours	
Air Cleaner/Filter	Inspect	Every 50 hours
	Clean	Monthly
		Every 3 months
Battery Level		Check monthly
Engine Fuel Filter		500 hours or 6 months
Spark Plug Maintenance		300 hours or annually
		500 hours or 6 months
Clean Fuel Tank(s)		Annually
Replace Fuel Lines		Annually
Pump Oil	Inspect	Oil level daily
	Change	After first 50 hours, then every 500 hours or annually (or 3 months)
Replace High Pressure Nozzle		Every 6 months
Replace Quick Connects		Annually
Clean Water Screen/Filter		Weekly
Replace HP Hose		Annually (if there are any signs of wear)
Belts	Tighten	Every 6 months
	Inspect/Replace	Every 6 months
Clean Float/Supply Tank		Every 6 months
Grease Motor		Every 10,000 hours
Clean Burner Filter		Monthly (more often if fuel quality is poor)
Remove Burner Soot		Annually
Burner Adjustment/Cleaning		Annually
Replace Burner Nozzle		Annually
Descale Coil		Annually (more often if required)

## OIL CHANGE RECORD

Check pump oil and engine oil level before first use of your new power washer.

Date Oil Changed Month/Day/Year	Estimated Operating Hours Since Last Oil Change	Date Oil Changed Month/Day/Year	Estimated Operating Hours Since Last Oil Change

## OPTIONS

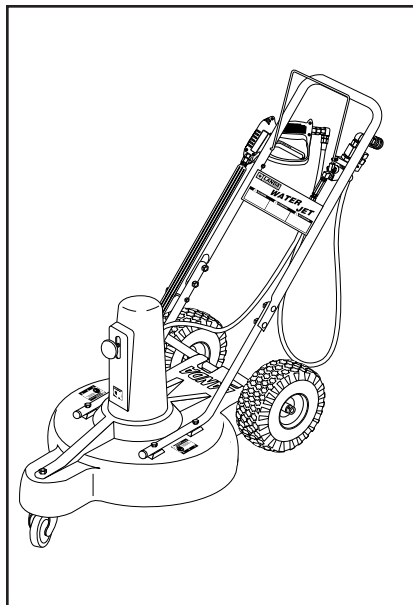

**Water Jet Surface Cleaner**  
#30-585

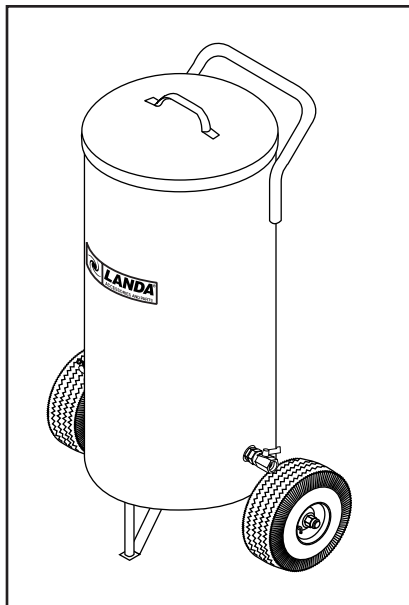

**Sand Blaster Pot (Carbide)**  
#4-011201

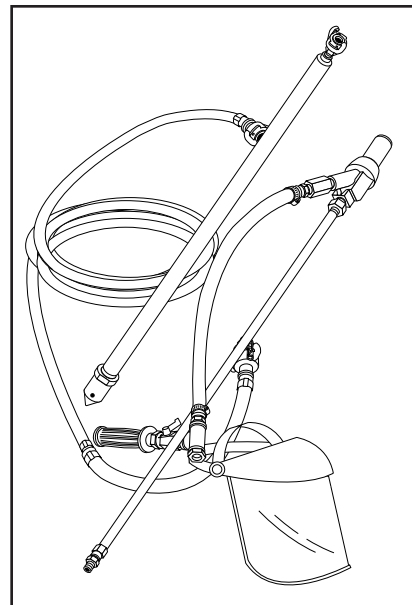

**Sand Blaster Wand W/Probe (Carbide)**  
#4-011211

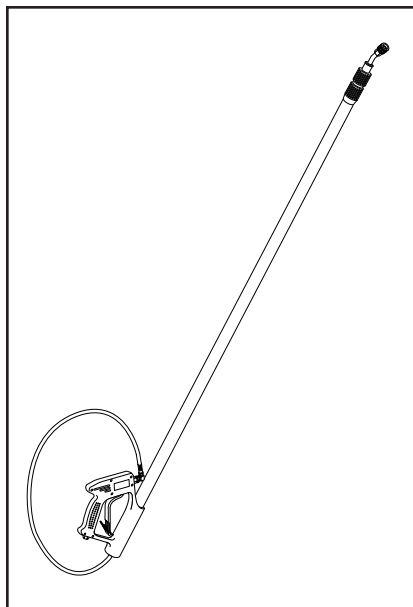

**Telescoping Wand, 12 Foot**  
#4-011012

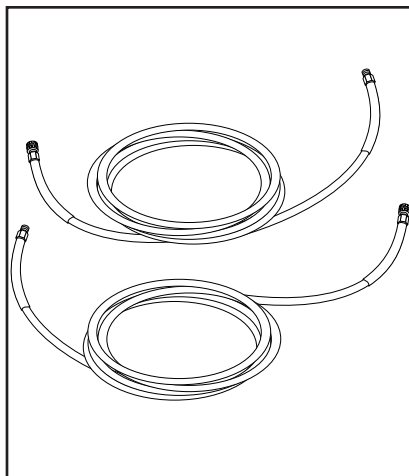

**50' Hose 3/8\", 3000 PSI, Rough Skin**  
#4-020350

**50' Hose 3/8\", 4500 PSI, Rough Skin**  
#4-020450

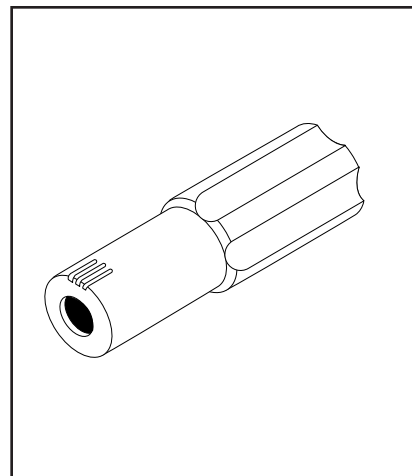

**Rotating Nozzle**  
#4-2023

**Set of Nozzles (Packaged)**  
#4-651504H

**O-Ring, 1/4\" and 3/8\" (Packaged)**  
#2-0123H

# EXPLODED VIEW - 4-2000, 4-3500

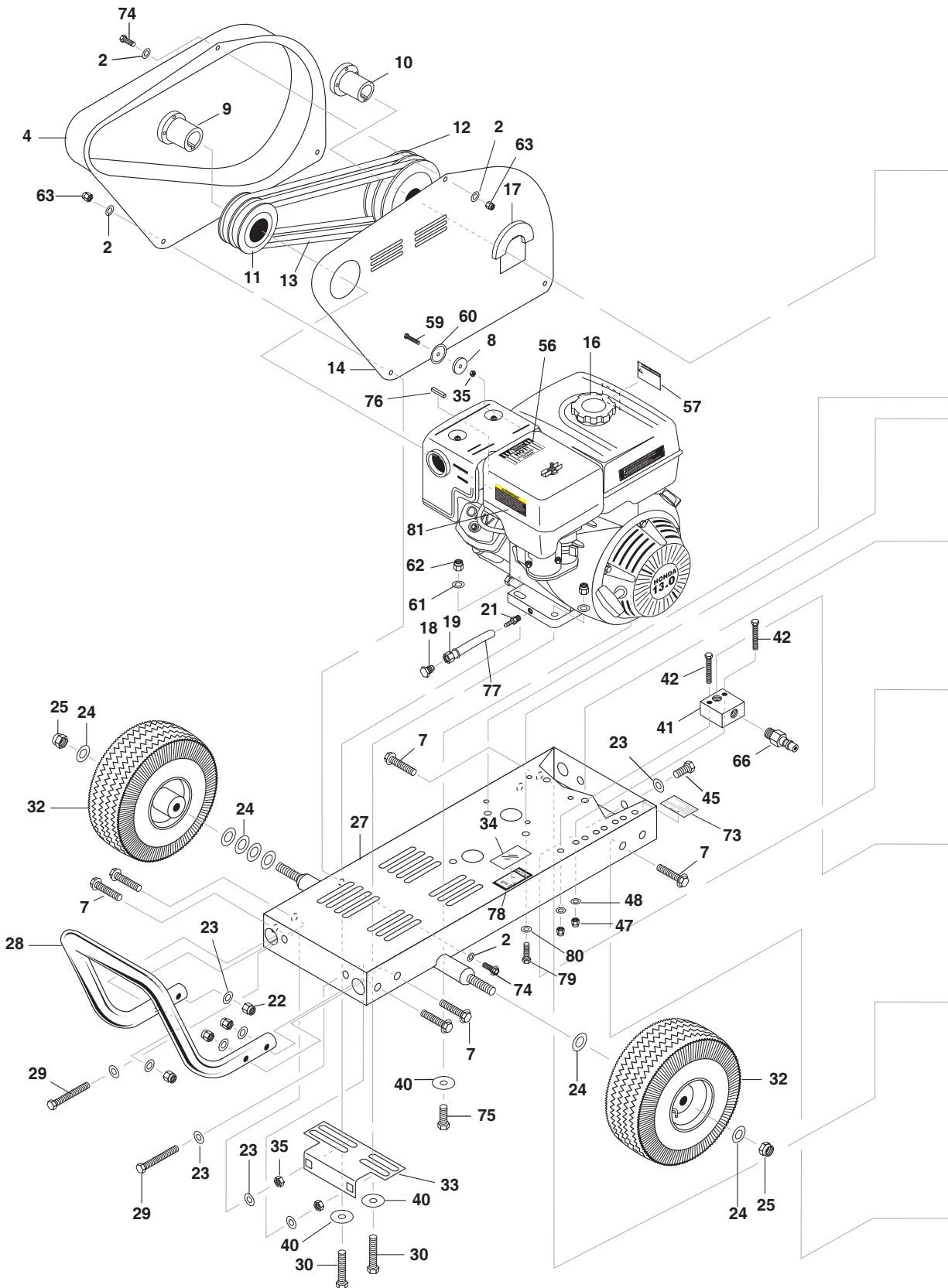



# EXPLODED VIEW - 4-2000, 4-3500

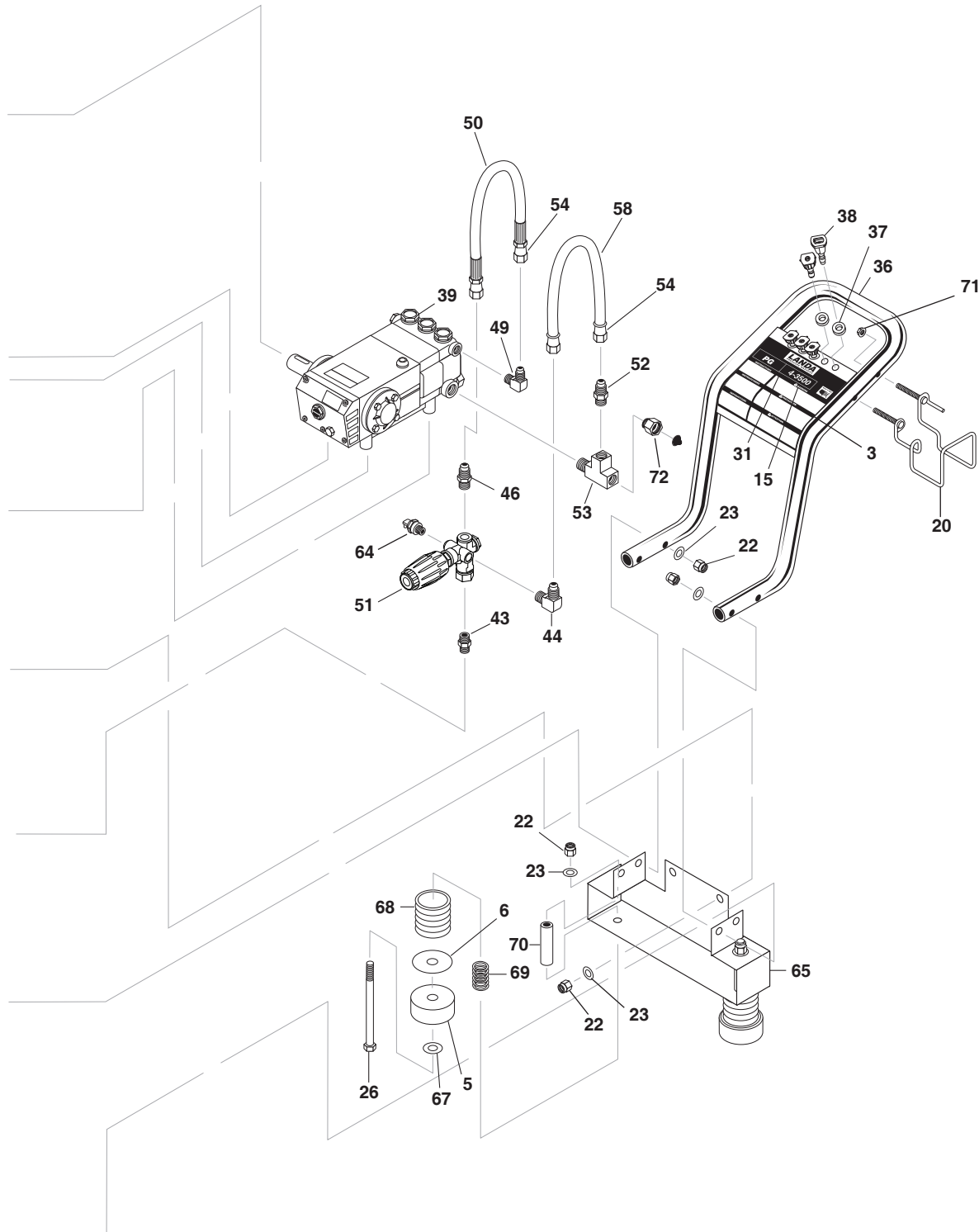

## EXPLODED VIEW - 4-2000, 4-3500 PARTS LIST

ITEM	PART NO.	DESCRIPTION	QTY	ITEM	PART NO.	DESCRIPTION	QTY
2	8.718-980.0	Washer, 5/16" Flat, SAE	6	35	9.802-789.0	Nut, 3/8", Hex, NC	3
3	8.900-818.0	Label, Operating Inst/Warn	1	36	8.925-056.0	Grab Assy, Grey	1
4	8.706-655.0	Guard, Belt, PG Small, Plastic (4-2000)	1	37	9.802-064.0	Grommet, Rubber (4-3500) (4-2000)	4 5
	8.706-656.0	Guard, Belt, PG Large, Plastic (4-3500)	1	38	8.712-345.0	Nozzle, SAQCMEG 0004, Red (4-3500)	1
5	9.802-066.0	Pad, Soft Rubber	2		8.712-346.0	Nozzle, SAQCMEG 1504, Yellow (4-3500)	1
6	9.802-819.0	Washer, 7/16" x 2-1/2", Zinc	2		8.712-347.0	Nozzle, SAQCMEG 2504, Green (4-3500)	1
7	8.718-674.0	Bolt, 3/8-16 X 2-1/4", GR8.2 Whiz Loc	8		8.712-348.0	Nozzle, SAQCMEG 4004, White (4-3500)	1
8	9.802-811.0	Washer, 3/8" x 1-1/2", Fender	1		8.712-361.0	Nozzle, SAQC Meg 0006, Red (4-2000)	1
9	Engine Bushing, See Specifications Pages				8.712-362.0	Nozzle, SAQC Meg 1506, Yellow (4-2000)	1
10	Pump Bushing, See Specifications Pages				8.712-363.0	Nozzle, SAQC Meg 2506, Green (4-2000)	1
11	Engine Pulley, See Specifications Pages				8.712-364.0	Nozzle, SAQC Meg 4006, White (4-2000)	1
12	Pump Pulley, See Specifications Pages			39	Pump, See Specifications Pages		
13	Belt, See Specifications Pages			40	9.802-811.0	Washer, 3/8" x 1-1/2" Fender	6
14	8.911-286.0	Back Plate, Belt Guard, PG Small (Landa Pump)	1	41	9.802-870.0	Block, Unloader, 3/8" x 3/8", 1.25, Steel	1
	8.933-026.0	Back Plate, Belt Guard, Large (PG4-3500)	1	42	9.802-728.0	Bolt, 3/8" x 2", NC HH	2
15	8.900-412.0	Label, 4-3500 Lexan	1	43	8.705-974.0	Nipple, 3/8" Hex Steel	1
	8.900-409.0	Label, 4-2000 Lexan	1	44	9.802-129.0	Elbow, 1/2" JIC x 3/8", 90°	1
16	Engine, See Specifications Pages			45	9.802-720.0	Bolt, 3/8" x 1" NC	2
17	8.932-993.0	Cushion, Pump, Thin	1	46	9.802-036.0	Nipple, 1/2" JIC, 3/8" Pipe	1
18	9.802-125.0	Plug, 1/4" JIC	1	47	9.197-003.0	Nut, 3/8" ESNA, NC	2
19	9.802-153.0	Swivel, 1/4" JIC Fem, Push-on	1	48	9.802-807.0	Washer, 3/8" SAE, Flat	2
20	9.803-098.0	Hanger, Hose & Wand	1	49	9.802-039.0	Elbow, 1/2" JIC, 3/8", 90°	1
21	9.802-154.0	Plug, Push-on, Oil Drain	1	50	8.918-424.0	Hose, 3/8" x 25", 2 Wire Pressure Loop	1
22	9.197-003.0	Nut, 3/8" ESNA, NC	12	51	Unloader, See Specifications Pages		
23	9.198-004.0	Washer, 3/8" Uss F/w Zinc	18	52	9.802-128.0	Nipple, 1/2" JIC x 1/2" MPT Pipe	1
24	9.802-810.0	Washer, 5/8" Flat, SAE	4	53	8.706-860.0	Tee, 1/2", Street	1
25	8.718-835.0	Nut, 5/8" Jam, ESNA, NC	2	54	9.802-151.0	Swivel, 1/2" JIC Fem, Push-On	2
26	8.718-684.0	Bolt, 3/8" x 5" NC	2	56	9.800-006.0	Label, Hot/Caliente	1
27	8.911-289.0	Frame, PG/PE Small (4-2000)	1	57	9.800-008.0	Label, Danger Cool Engine	1
	8.920-223.0	Frame, Large Belt Drive (4-3500)	1	58	9.802-259.0	Hose, 1/2", Push-On	15"
28	8.925-055.0	Handle, Bumper, Grey	1	59	9.802-720.0	Bolt, 3/8" x 1" NC, HH	1
29	9.802-733.0	Bolt, 3/8" x 3-1/2", Tap	2	60	9.802-067.0	Bumper Pad, Engine	1
30	9.802-728.0	Bolt, 3/8" x 2"	2	61	9.802-807.0	Washer, 3/8" SAE, Flat	4
31	8.900-247.0	Label, PG (Lexan)	1	62	9.197-003.0	Nut, 3/8" ESNA, NC	4
32	8.754-186.0	Qh Wheel Assy, 10" Gray Steel Rim W/Tube	2	63	9.802-776.0	Nut, 5/16" ESNA	3
	8.754-435.0	Wheel & Pu Tire Assy, 12" steel rim (4-3500) (4-2000)	2	64	8.707-254.0	Pump Protector, 3/8" PTP	1
33	8.719-905.0	Bracket, Belt Tension	1	65	8.911-293.0	Bracket, Wide Foot	1
34	9.800-034.0	Label, Clear Lexan	1				

## EXPLODED VIEW - 4-2000, 4-3500 PARTS LIST

ITEM	PART NO.	DESCRIPTION	QTY
66	9.802-171.0	Nipple, 3/8" x 3/8" NPT ST Male	1
67	9.802-817.0	Washer, 3/8" x 1" Steel	2
68	8.706-557.0	Bellows, LEG (Boot)	2
69	8.719-091.0	Spring, Foot Compression	2
70	8.719-954.0	Tube, Foot Bolt	2
71	9.802-778.0	Nut, 5/16" Whiz Loc Flange	3
72	9.802-146.0	Swivel, 1/2" MPT x 3/4" GHF	1
73	9.800-049.0	Label, Manufacturer's Cleaning Solution	1
74	9.802-710.0	Bolt, 5/16" x 1" NC, HH	2
75	9.802-727.0	Bolt, 3/8" x 1-3/4" Tap	2
76	9.802-959.0	Key, .247 x 2.125"	1
77	9.802-254.0	Hose, 1/4" Push-On, Fuel Line 4"	4"
78	8.932-968.0	Label, Intended For Outdoor	1
79	9.802-744.0	Bolt 10mm x 20mm HH	4
80	9.802-816.0	Washer 7/16 Lock Split	4
81	8.751-096.0	Label, Regulation 4442.6	1

# EXPLODED VIEW - 4-4000, 5-3500

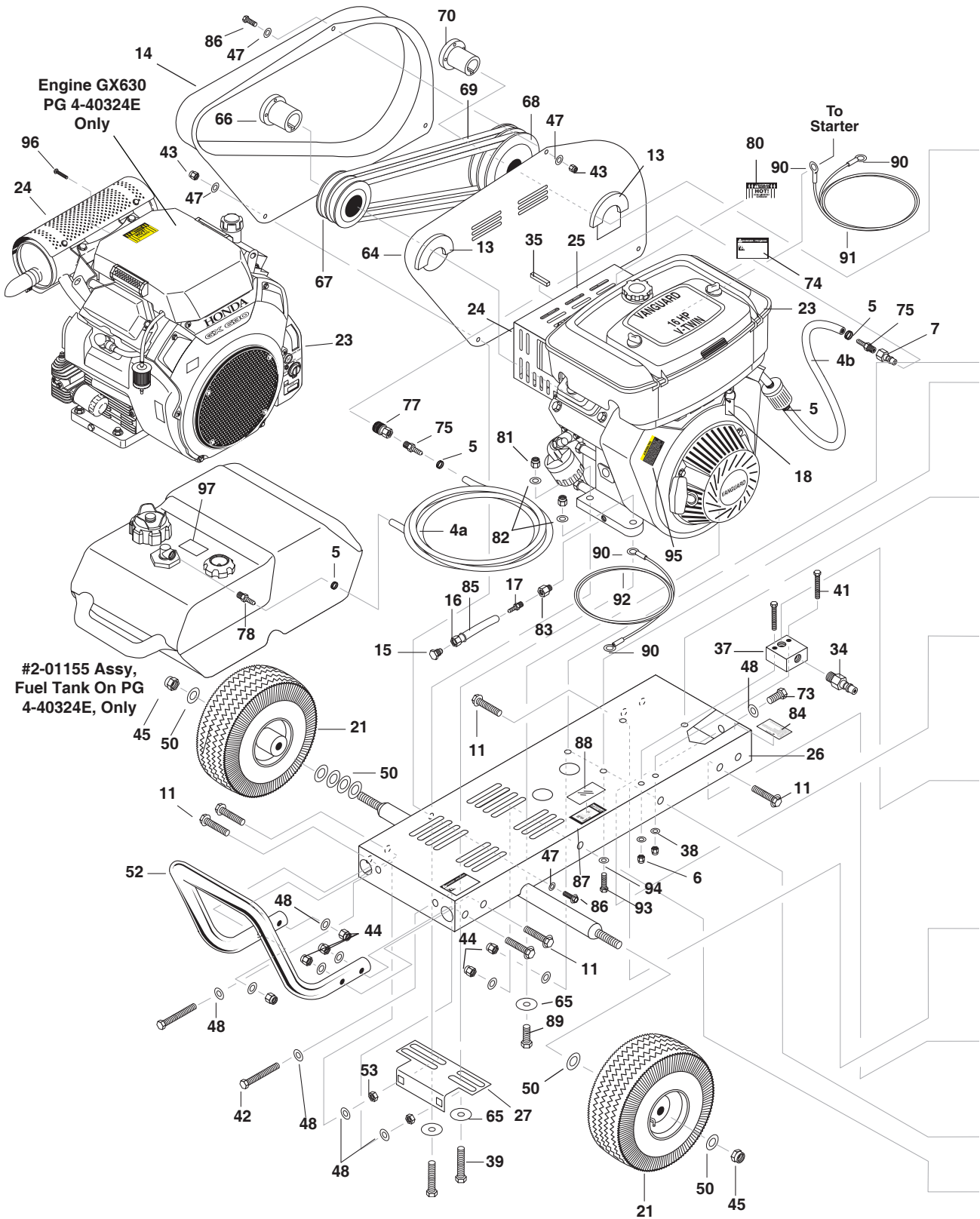

# EXPLODED VIEW - 4-4000, 5-3500

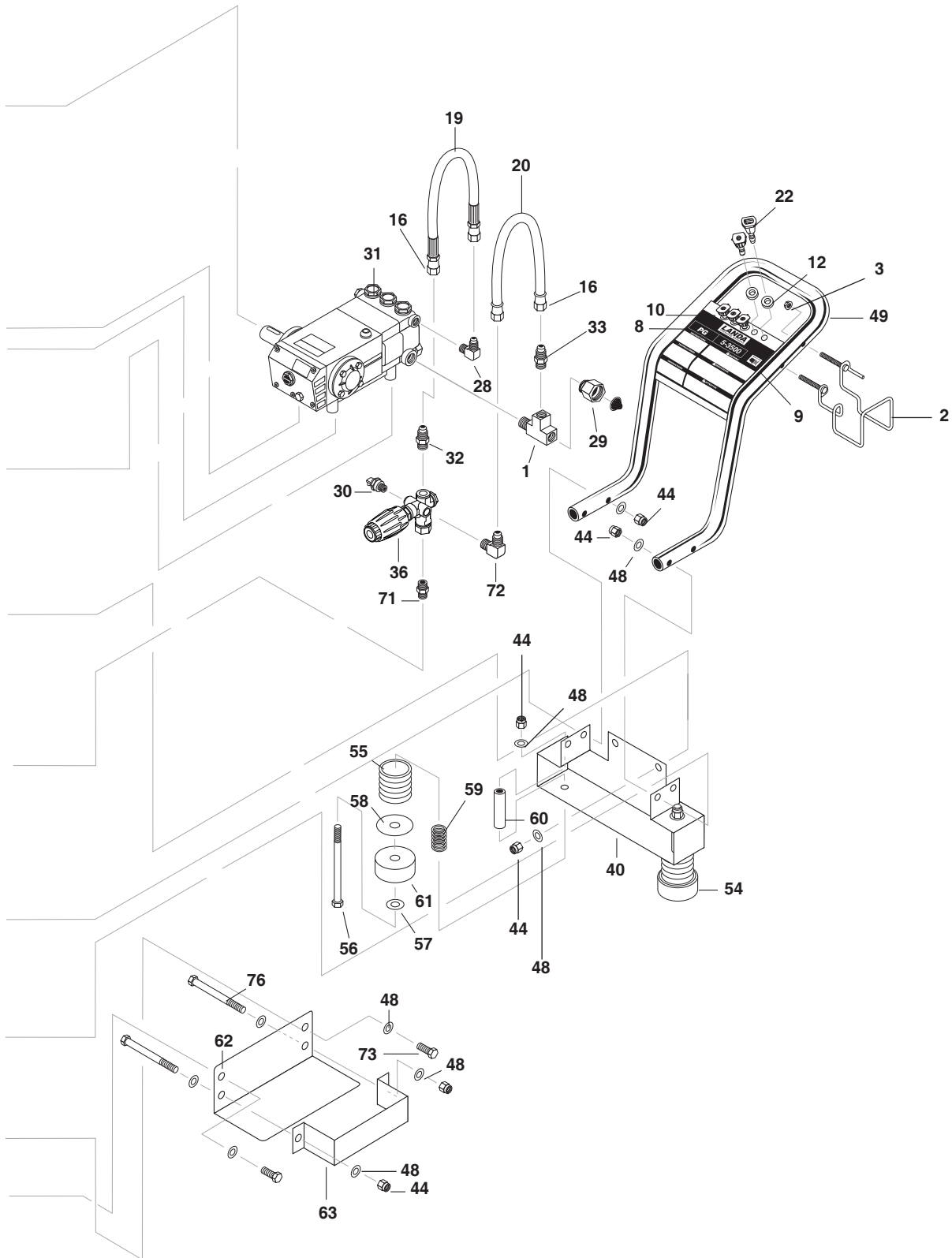

## EXPLODED VIEW - 4-4000, 5-3500 PARTS LIST

ITEM	PART NO.	DESCRIPTION	QTY	ITEM	PART NO.	DESCRIPTION	QTY
1	8.706-860.0	Tee, 1/2" Street	1	24	8.750-498.0	Muffler, Honda GX630/GX660 Left	1
2	9.803-098.0	Hanger, Hose & Wand	1		8.915-687.0	▲ Deflector, Exhaust, Honda	1
3	9.802-778.0	Nut, 5/16" Whiz Loc Flange	2		9.802-867.0	Guard, Muffler, Briggs (Vanguard)	1
4a	9.802-254.0	Hose, 1/4", Push-On (4-40324E )	4 ft.		9.802-868.0	▲ Brace (Vanguard)	2
4b	9.802-254.0	Hose, 1/4", Push-On (4-40324E)	19"		9.802-793.0	▲ Nut Cage, 1/4" x 16 Gauge (Vanguard)	4
5	9.802-210.0	Clamp, Hose, UNI .46 - .54 (Honda)	4		9.802-754.0	▲ Screw, 1/4" x 1/2" HHNC, Whiz Loc (Vanguard)	4
6	9.197-003.0	Nut, 3/8" ESNA, NC	2		9.802-830.0	▲ Screw, Hex 1/4-20 x 1/2" (Vanguard)	4
7	8.707-179.0	Nipple, Coupler, Fuel Line (4-40324E)	1	25	9.803-631.0	Muffler, Exhaust Skid & PG, Briggs (Vanguard)	1
8	8.900-247.0	Label, PG (Lexan)	1		8.718-156.0	Muffler, Honda, Left	1
9	8.900-415.0	Label, 5-3500 (Lexan)	1	26	8.920-223.0	Frame, PG, Large (5-35224E)	1
	8.900-413.0	Label, 4-4000 (Lexan)	1		8.911-297.0	Frame, Large (4-40324E)	1
10	8.900-818.0	Label, Operating Inst/Warn	1	27	8.719-903.0	Bracket, Belt Tension	1
11	8.718-674.0	Bolt, 3/8-16 X 2-1/4",GR8.2 Whiz Loc	8	28	9.802-039.0	Elbow, 1/2" JIC, 3/8", 90°	1
12	9.802-064.0	Grommet, 1/8" Rubber	4	29	9.802-146.0	Swivel, 1/2" MP x 3/4" GHF W/Strainer	1
13	9.804-081.0	Cushion, Pump (Thin)	2	30	8.707-254.0	Pump Protector, 3/8" PTP	1
14	8.706-656.0	Belt Guard, PG-Large, Plastic	1	31	Pump, See Specifications Pages		
15	9.802-126.0	Plug, 1/2" JIC, Flare	1	32	9.802-036.0	Nipple, 1/2" JIC x 1/2" Pipe	1
16	9.802-151.0	Swivel, 1/2" JIC Fem, Push-on	3	33	9.802-128.0	Nipple, 1/2" JIC x 1/2" MPT Pipe	1
17	8.707-019.0	Push-on, 3/8" Male Pipe	1	34	9.802-171.0	Nipple, 3/8" x 3/8" NPT ST Male	1
18	8.913-902.0	Key Ring, #1 w/Landa	1	35	9.802-673.0	Key, Motor Shaft (Vanguard)	1
19	8.918-424.0	Hose, 3/8" X 25", 100R2, Pres Loop	1		9.802-959.0	Key, Motor Shaft (Honda)	1
20	9.802-259.0	Hose, 1/2" Push-On	15"	36	Unloader, See Specifications Pages		
21	8.754-435.0	Wheel & PU Tire Assy, 12" Steel Rim	2	37	9.802-870.0	Block, Unloader, 3/8" x 3/8" Brass	1
22	8.712-353.0	Nozzle, SAQMEG, 0005, Red 0° (5-3500)	1	38	9.802-807.0	Washer, 3/8" SAE, Flat	2
	8.712-354.0	Nozzle, SAQMEG, 1505, Yellow 15° (5-3500)	1	39	9.802-716.0	Bolt, 5/16" x 2", NC HH (Vanguard)	4
	8.712-355.0	Nozzle, SAQMEG, 2505, Green 25° (5-3500)	1		9.802-728.0	Bolt, 3/8" x 2" NC HH (Honda)	2
	8.712-356.0	Nozzle, SAQMEG, 4005, White 40° (5-3500)	1	40	8.911-293.0	Bracket, Wide Foot	1
	8.712-345.0	Nozzle, SAQMEG, 0004, Red, 0° (4-4000)	1	41	9.802-728.0	Bolt, 3/8" x 2" NC, HH	2
	8.712-346.0	Nozzle, SAQMEG, 1504, Yellow, 15° (4-4000)	1	42	9.802-733.0	Bolt, 3/8" x 3-1/2", Tap	2
	8.712-347.0	Nozzle, SAQMEG, 2504, Green, 25° (4-4000)	1	43	9.802-776.0	Nut, 5/16" ESNA, NC	3
	8.712-348.0	Nozzle, SAQMEG, 4004, White, 40° (4-4000)	1	44	9.197-003.0	Nut, 3/8" ESNA, NC	16
23	Engine, See Specifications Pages			45	8.718-835.0	Nut, 5/8" JAM, ESNA, NF	2
				47	8.718-980.0	Washer, 5/16" Flat, SAE	6
				48	9.198-004.0	Washer, 3/8" Uss F/w Zinc	26
				49	8.939-025.0	Handle, 1-1/4" Chrome	1
				50	9.802-810.0	Washer, 5/8" Flat, SAE	4

## EXPLODED VIEW - 4-4000, 5-3500 PARTS LIST

ITEM	PART NO.	DESCRIPTION	QTY	ITEM	PART NO.	DESCRIPTION	QTY
52	8.920-250.0	Handle, Bumper 1-1/4" Chrome Grab	1	85	9.802-259.0	Hose, 1/2" Push-On	4"
53	9.802-789.0	Nut, 3/8" Hex, NC	2	86	9.802-710.0	Bolt, 5/16" x 1" NC, HH	2
54	8.906-774.0	Foot Assy w/out Bracket	2	87	8.932-968.0	Label, Intended For Outdoor	1
55	8.706-557.0	Bellow, Leg (Boot)	2	88	9.800-034.0	Label, Clear Lexan	1
56	8.718-684.0	Bolt, 3/8" x 5" NC, HH, Tap	2	89	9.802-727.0	Bolt, 3/8" x 1-3/4" Tap	2
57	9.802-817.0	Washer, 3/8" x 1"	2	90	8.751-101.0	Terminal, Ring Tongue, S6-38R	4
58	9.802-819.0	Washer, 7/16" x 2-1/2" Zinc	2	91	9.803-836.0	Wire, THWN 6 GA Red	17"
59	8.719-091.0	Spring, Foot, Compression	2	92	9.803-837.0	Wire, THNN, 6 GA Black	17"
60	8.719-954.0	Tube, Foot Bolt, PC	2	93	9.802-744.0	Bolt 10mm x 20mm HH	4
61	9.802-066.0	Pad, Soft Rubber	2	94	9.802-816.0	Washer 7/16 Lock Split	4
62	8.911-258.0	Holder, Battery, PG	1	95	8.917.015.0	Label, Regulation 4442.6	1
63	8.719-901.0	Clamp, Battery, PG	1	96	8.718-781.0	Screw M5 X 8 X 40MM, Pan Head (PG 4-40324E)	1
64	8.719-905.0	Back Plate, Belt Guard, PG, Lg. 1		97	8.921-479.0	Label, CO10 Carb Compliance	1
65	9.198-014.0	Washer, 5/16" x 1-1/4", Fender, 6 SAE (Vanguard)	6	▲ Not Shown			
	9.802-811.0	Washer, 3/8" x 1-1/2" Fender (Honda)	6				
66	Engine Bushing, See Specifications Pages						
67	Engine Pulley, See Specifications Pages						
68	Pump Pulley, See Specifications Pages						
69	Belt, See Specifications Pages						
70	Pump Bushing, See Specifications Pages						
71	8.705-974.0	Nipple, 3/8" Hex	1				
72	9.802-129.0	Elbow, 1/2" JIC x 3/8"	1				
73	9.802-720.0	Bolt, 3/8" x 1" NC, HH	4				
74	9.800-008.0	Label, Danger Cool Engine	1				
75	8.706-940.0	Hose Barb, 1/4" Barb x 1/8" ML 2 (Fuel Tank Assy 4-40324E)					
76	9.802-730.0	Bolt, 3/8" x 2-1/2" GR 5 ZN	2				
77	8.707-178.0	Coupler, Fuel Line, Quick (4-40324E)	1				
78	8.706-941.0	Hose Barb, 1/4" Barb x 1/4", ML Pipe	1				
79	8.751-294.0	Fuel Tank, 6 Gal (4-40324E)	1				
80	9.800-006.0	Label, Hot	1				
81	9.802-776.0	Nut, 5/16" ESNA (Vanguard)	4				
	9.197-003.0	Nut, 3/8" ESNA, (Honda)	4				
82	8.718-980.0	Washer, 5/16" Flat (Vanguard)	4				
	9.802-807.0	Washer, 3/8" Flat (Honda)	4				
83	8.750-737.0	Adapter, 3/8" x 1/4" (Honda)	1				
84	9.800-049.0	Label, Manufacturer's Cleaning Solution	1				

## HOSE & SPRAY GUN ASSEMBLY

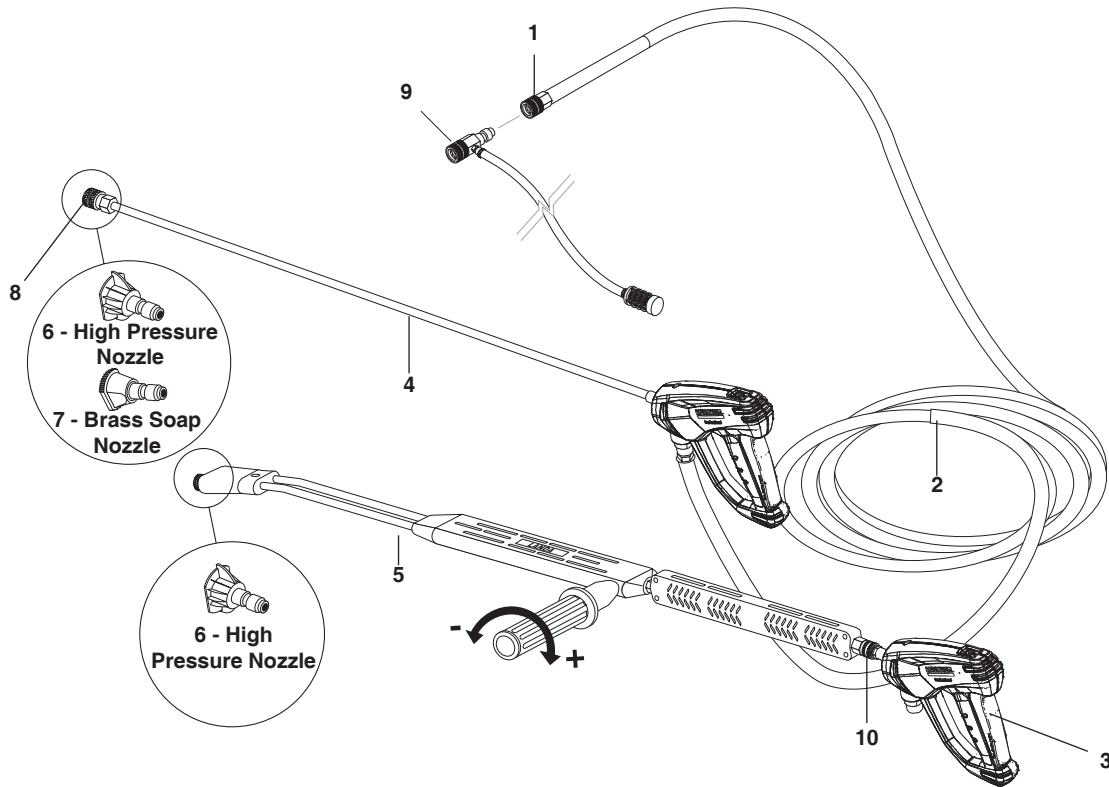

### HOSE & SPRAY GUN ASSEMBLY PARTS LIST

ITEM	PART NO.	DESCRIPTION	QTY
1	9.802-166.0	Coupler, 3/8" Female	1
		8.706-703.0 ▲ Quick Coupler O-Ring, 1/4" & 3/8" (Packaged)	1
2	8.739-213.0	Hose 3/8" x 50', 2-Wire Tuff-FLex	1
3	4.775-054.0	EASY!Force Advanced KNA	1
4	8.904-430.0	Wand, Straight w/Coupler Assy (4-2000)	1
5	8.711-293.0	Wand, VP AL344 Assy (4-3500, 4-4000, 5-3500)	1
6		Pressure Nozzle, See Exploded Views	
7	8.712-398.0	Brass Soap Nozzle (4-2000)	1
8	9.802-164.0	Coupler, 1/4" Female (4-2000)	1
	9.802-165.0	Coupler, 1/4" Male Brass (4-3500, 4-4000, 5-3500)	1
	9.802-096.0	▲ O-Ring, Coupler Quick Sm HI-HT	1
	8.706-712.0	▲ Seal 1/4"	1
9	9.802-225.0	Detergent Injector Assy.	1
10	8.707-139.0	Coupler, 1/4" Plug, Male, Steel/Zinc (MP-373534,MP-343084E)	1

▲ Not Shown



## DOWNSTREAM INJECTOR ASSEMBLY

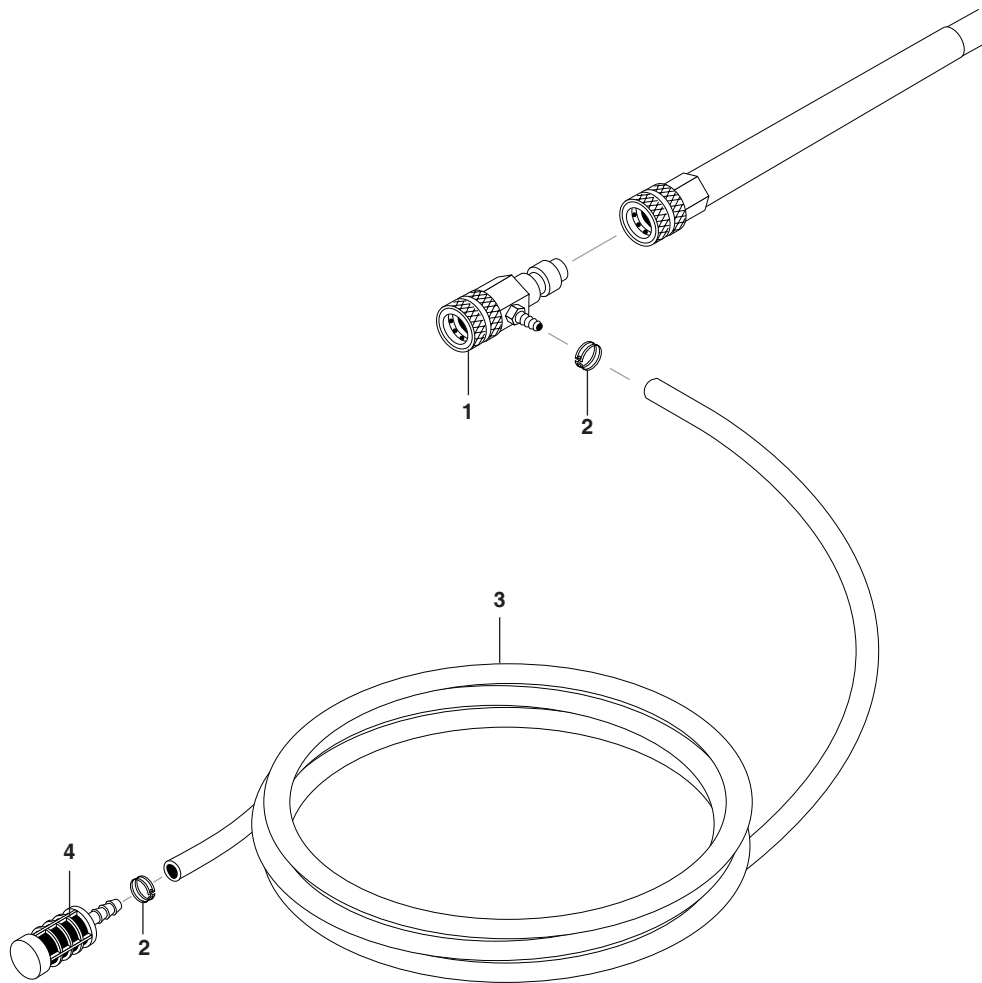

## DOWNSTREAM INJECTOR ASSEMBLY

ITEM	PART NO.	DESCRIPTION	QTY
1	9.802-216.0	Detergent Injector Non Adjust, #3	1
2	9.802-210.0	Clamp, Hose, UNI .46 - .54	2
3	9.802-251.0	Tube, 1/4" x 1/2", Clear Vinyl	6 ft.
4	8.707-057.0	Strainer, 1/4" Hose Barb	1

## SPECIFICATIONS

### PARTS SPECIFICATIONS: LANDA PUMP

Machine		PUMP					ENGINE			
Model	Model	Part #	Pulley	Pulley Part #	Bushing	Bushing Part #	Belt Size/Qty	Belt Part #	Size	Type
4-20324	LT4540	8.921-710.0	2AK84H	9.802-375.0	25mm	9.802-403.0	AX37 (2)	9.802-409.0	GX270 (270cc)	HONDA
4-35324	LT4540	8.921-710.0	2BK90H	8.715-593.0	25mm	9.802-403.0	BX42 (2)	8.715-703.0	GX390 (390cc)	HONDA
4-40324E	LT4540	8.921-710.0	2BK90H	8.751-593.0	25mm	9.802-403.0	BX40 (2)	8.715-701.0	OGX630 (688cc)	HONDA
5-35224E	LT6036	8.921-712.0	2BK90H	8.715-593.0	25mm	9.802-403.0	BX41 (2)	8.715-702.0	Vanguard (470cc)	Briggs

# SPECIFICATIONS

ENGINE (CON'T)						MISCELLANEOUS					
Machine	Part #	Pulley	Pulley Part #	Bushing Part #	Bushing	Unloader Type	Unloader Part #	Tire Part #	High Pres Nozzle	Soap Nozzle Part #	Det. Jet Part
4-20324	8.750-680.0	2AK34H	9.804-047.0	HX1"	9.802-399.0	VRT3	8.750-300.0	8.754-186.0	06 (4)	8.712-398.0	9.802-225.0
4-35324	8.750-580.0	2BK32H	8.715-576.0	HX1"	9.802-399.0	VRT3	8.750-300.0	9.802-271.0	04 (4)	N/A	9.802-225.0
4-40324E	8.752-149.0	2BK32H	8.715-576.0	HX1"	9.802-399.0	VRT3	8.750-300.0	9.802-271.0	04 (4)	N/A	9.802-225.0
5-35224E	8.715-068.0	2BK32H	8.715-576.0	HX1"	9.802-399.0	VRT3	8.750-300.0	9.802-271.0	05 (4)	N/A	9.802-225.0

## LT.2 PUMP EXPLODED VIEW AND PARTS LIST

8.921-710.0 LT4540.2 Right  
 8.921-711.0 LT4540.2 Left  
 8.921-712.0 LT6036.2 Right  
 8.921-713.0 LT6036.2Left

# G3 Evolution

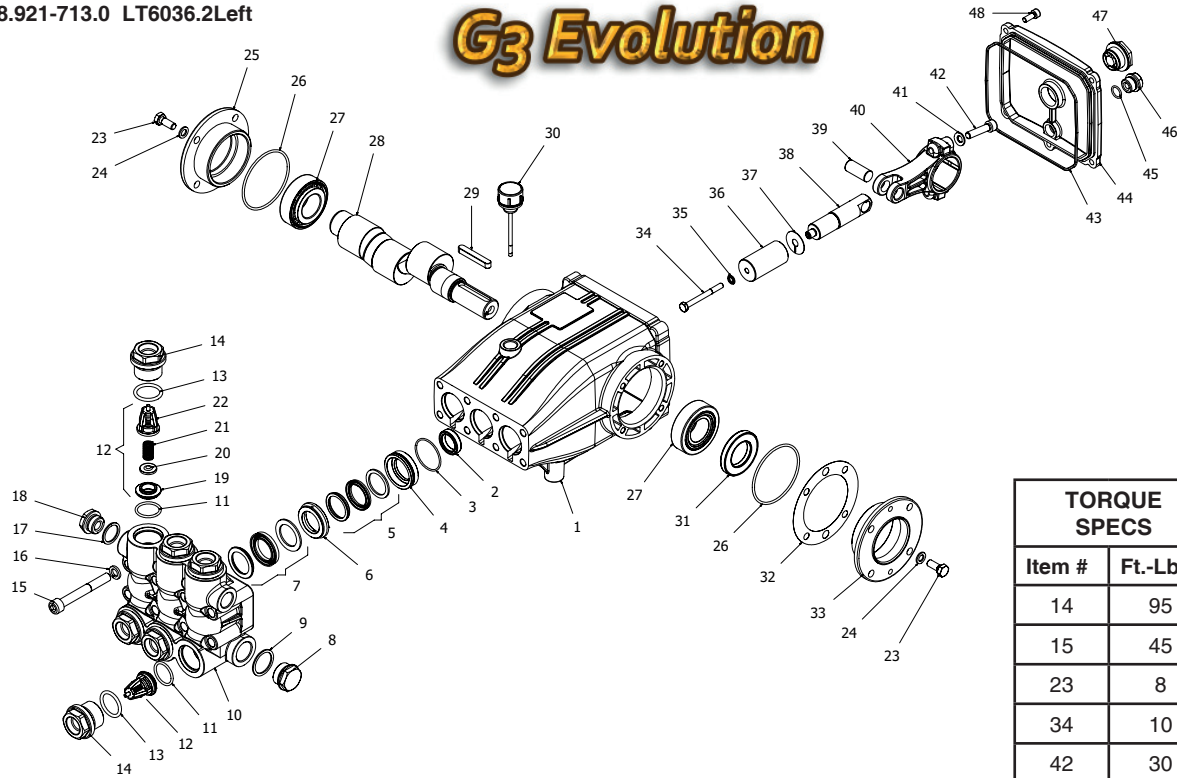

TORQUE SPECS	
Item #	Ft.-Lbs.
14	95
15	45
23	8
34	10
42	30
48	8

## LT PUMP EXPLODED VIEW PARTS LIST

ITEM	PART NO.	DESCRIPTION	QTY	ITEM	PART NO.	DESCRIPTION	QTY
1	8.752-825.0	Crankcase	1	19	See Kit Below	Valve Seat	6
2*	See Kit Below	Plunger Oil Seal	3	20	See Kit Below	Valve Plate	6
3*	See Kit Below	O-Ring Ø1.78 x 37.82	3	21	See Kit Below	Valve Spring	6
4*	See Kit Below	"Pressure Ring, Brass	3	22	See Kit Below	Valve Cage	6
5*	See Kit Below	"U" Seal 18mm	3	23	8.725-830.0	Hexagonal Screw	8
6*	See Kit Below	Intermediate Ring, 18mm	3	24	9.802-884.0	Washer	8
7*	See Kit Below	"U" Seal, 18mm	3	25	9.803-182.0	Closed Bearing Housing	1
8	9.802-926.0	Brass Plug, G1/2	1	26	9.803-186.0	O-Ring Ø2.62 x 71.12	2
9	9.803-199.0	Cooper Washer 1/2	1	27	9.803-160.0	Roller Bearing	2
10	8.753-816.0	Manifould Housing	1				
11*	9.804-498.0	O-Ring Ø2.62 x 25.1	6	28	8.753-818.0	Crankshaft Ø24 (4540)	1
12*	See Kit Below	Valve Assembly	6		8.752-827.0	Crankshaft Ø24 (6036)	1
13*	9.803-193.0	O-Ring 3068	6	29	9.803-167.0	Cranckshaft Key	1
14	9.802-928.0	Valve Plug	6	30	8.752-834.0	Oil Dipstick	1
15	8.753-817.0	Manifould Stud Bolt	8	31	9.803-139.0	Crankshaft Seal	1
16	9.802-890.0	Lock Washer	8	32	9.803-177.0	Shim	2
17	8.719-008.0	Cooper Washer 3/8	1	33	9.803-181.0	Bearing Housing	3
18	8.707-262.0	Brass Plug 3/8	1	34*	8.752-841.0	Plunger Bolt	3

## LT PUMP EXPLODED VIEW PARTS LIST (CONT)

ITEM	PART NO.	DESCRIPTION	QTY
35*	8.752-820.0	Bonded Seal	3
36*	8.753-819.0	Plunger 18mm	3
37*	8.752-823.0	Copper Spacer	3
38	See Kit Below	Plunger Rod	3
39	8.752-822.0	Connecting Rod Pin	3
40	8.752-821.0	Connecting Rod	3
41	9.802-889.0	Spring Washer	6
42	9.802-937.0	Connecting Rod Screw	6
43	9.803-194.0	O-Ring Ø2.62 x 152.07	1
44	8.752-826.0	Crankcase Cover	1
45	9.803-906.0	O-Ring Ø1.78 x 14.00	1
46	8.707-262.0	Brass Plug G 3/8	1
47	9.803-202.0	Sight Glass G3/4	1
48	8.752-824.0	Cover Screw	5

\* Part available in kit (See below)

REPAIR KIT NUMBER	8.753-821.0	8.753-822.0	8.753-823.0	8.753-824.0	8.752-835.0
KIT DESCRIPTION	Plunger Seal 18mm	Seal Packing 18mm	Plunger 18mm	Complete Valve	Plunger Oil Seals
ITEM NUMBERS INCLUDED	3,5,7	3,4,5,6,7	34,35,36,37	11,12,13	2
NUMBER OF CYLINDERS KIT WILL SERVICE	3	1	1	6	3

# LT PUMP EXPLODED VIEW AND PARTS LIST

- 8.904-869.0 LT4035.1 Right
- 8.904-870.0 LT4035.1 Left
- 8.904-871.0 LT4040.1 Right
- 8.904-872.0 LT4040.1 Left
- 8.904-874.0 LT5030.1 Right
- 8.904-879.0 LT5030.1 Left
- 8.904-881.0 LT6035.1 Right
- 8.904-883.0 LT6035.1 Left

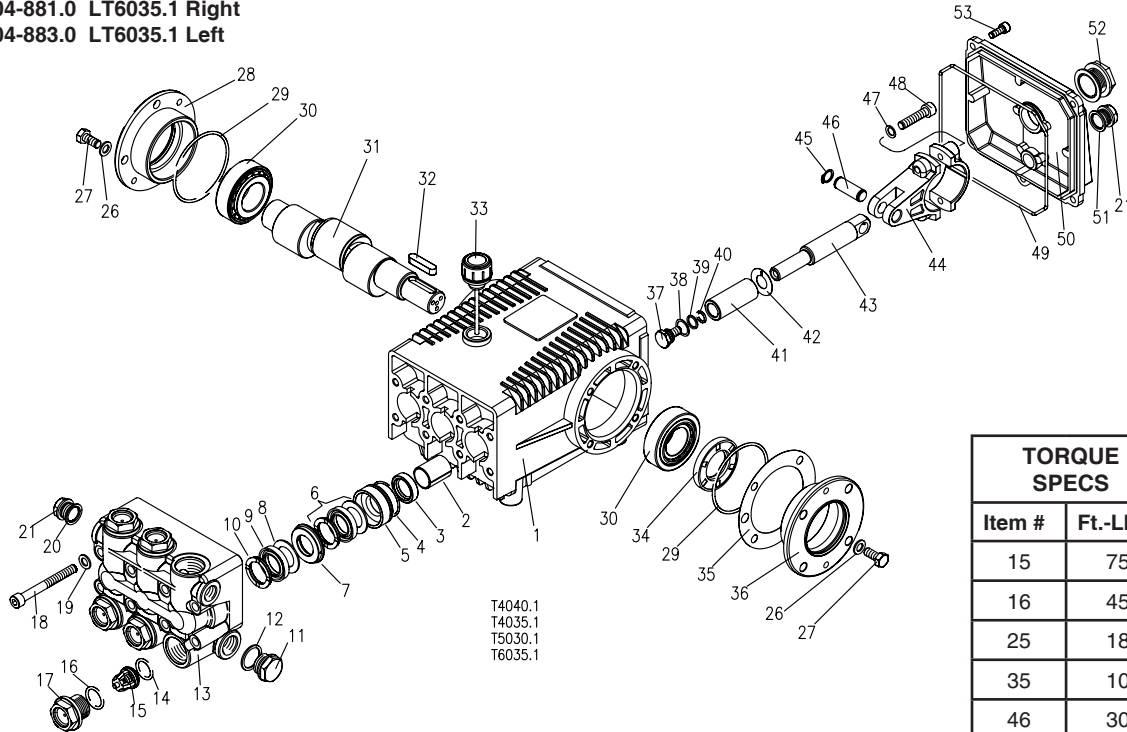

TORQUE SPECS	
Item #	Ft.-Lbs.
15	75
16	45
25	18
35	10
46	30
51	7.6

## LT PUMP EXPLODED VIEW PARTS LIST

ITEM	PART NO.	DESCRIPTION	QTY	ITEM	PART NO.	DESCRIPTION	QTY
1	9.803-163.0	Crankcase	1	19	9.802-890.0	Washer	8
2	9.803-195.0	Plunger Guide	3	20*	9.803-198.0	Copper Washer 3/8"	1
3*	See Kit Below	Plunger Oil Seal	3	21*	9.802-925.0	Brass Plug 3/8"	1
4*	See Kit Below	O-Ring Ø1.78 x 31.47	3	26	9.802-884.0	Washer	8
5*	See Kit Below	"Pressure Ring, Brass	3	27	9.802-944.0	Hexagonal Screw	8
6*	See Kit Below	"U" Seal Low Pressure	3	28	9.803-182.0	Closed Bearing Housing	1
7*	See Kit Below	Intermediate Ring, Brass	3	29	9.803-186.0	O-Ring Ø2.62 x 71.12	2
8*	See Kit Below	Support Ring, Teflon Bronze	3	30	9.803-160.0	Roller Bearing, Tapered	2
9	See Kit Below	"U" Seal High Pressure	3	31	9.803-148.0	Crankshaft (GT4040.1, 5030.1, 6035.1)	1
10	See Kit Below	Support Ring	3		9.803-149.0	Crankshaft (GT 4035.1)	1
11	9.802-926.0	Brass Plug, 1/2"	1	32	9.803-167.0	Crankshaft Key	1
12*	9.803-199.0	Copper Washer 1/2"	1	33	9.802-923.0	Oil Dip Stick	1
13*	9.802-933.0	Manifold Head	1	34	9.803-139.0	Crankshaft Seal	1
14*	See Kit Below	O-Ring Ø2.62 x 17.13	6	35	9.803-177.0	Shim	2
15	See Kit Below	Valve Assembly	6	36	9.803-181.0	Bearing Housing	1
16	See Kit Below	O-Ring Ø2.62 x 20.29	6	37*	9.803-235.0	Plunger Bolt	3
17	9.802-928.0	Valve Plug	6	38*	9.802-886.0	Copper Spacer	3
18	9.802-943.0	Manifold Stud Bolt	8				

## LT PUMP EXPLODED VIEW PARTS LIST (CONT)

ITEM	PART NO.	DESCRIPTION	QTY
39*	9.803-187.0	O-Ring Ø1.78 x10.82	3
40*	9.803-154.0	Teflon Ring	3
41*	See Kit Below Plunger		3
42*	See Kit Below Copper Spacer		3
43	9.803-143.0	Plunger Rod	3
44	9.803-157.0	Connecting Rod	3
45	9.802-912.0	Snap Ring	6
46	9.802-915.0	Connecting Rod Pin	3
47	9.802-889.0	Spring Washer	6
48	9.802-937.0	Connecting Rod Screw	6
49	9.803-194.0	O-Ring Ø2.62 x 152.07	1
50	9.803-166.0	Crankcase Cover	1
51	9.803-197.0	Gasket, G3/8	1
52	9.803-202.0	Sight Glass G3/4	1
53	9.802-939.0	Cover Screw	5

\* Part available in kit (See below)

REPAIR KIT NUMBER	8.916-488.0	8.916-487.0	8.916-322.0	8.916-323.0	9.802-607.0	9.802-611.0	9.802-603.0	9.802-606.0
KIT DESCRIPTION	Plunger "U" Seal 20mm LT-4040.1, LT-6035.1 LT-4035.1	Plunger "U" Seal 22mm LT-5030.1	"U" Seal Packing Assy 20mm LT-4040.1 LT-6035.1 LT-4035.1	"U" Seal Packing Assy 22mm LT-5030.1	Plunger 20mm LT-4040.1 LT-6035.1 LT-4035.1	Plunger 22mm LT-5030.1	Complete Valve (all pumps)	Plunger Oil Seals (all pumps)
ITEM NUMBERS INCLUDED	4, 7, 22	4, 7, 22	4, 5, 6, 7, 8, 20, 21, 22, 23	4, 5, 6, 7, 8, 20, 21, 22, 23	35, 36, 37, 38, 39, 40	35, 36, 37, 38, 39, 40	12, 13, 14	3

# VRT3 UNLOADER EXPLODED VIEW AND PARTS LIST

8.750-300.0, 8 GPM, 4500 PSI EZ START

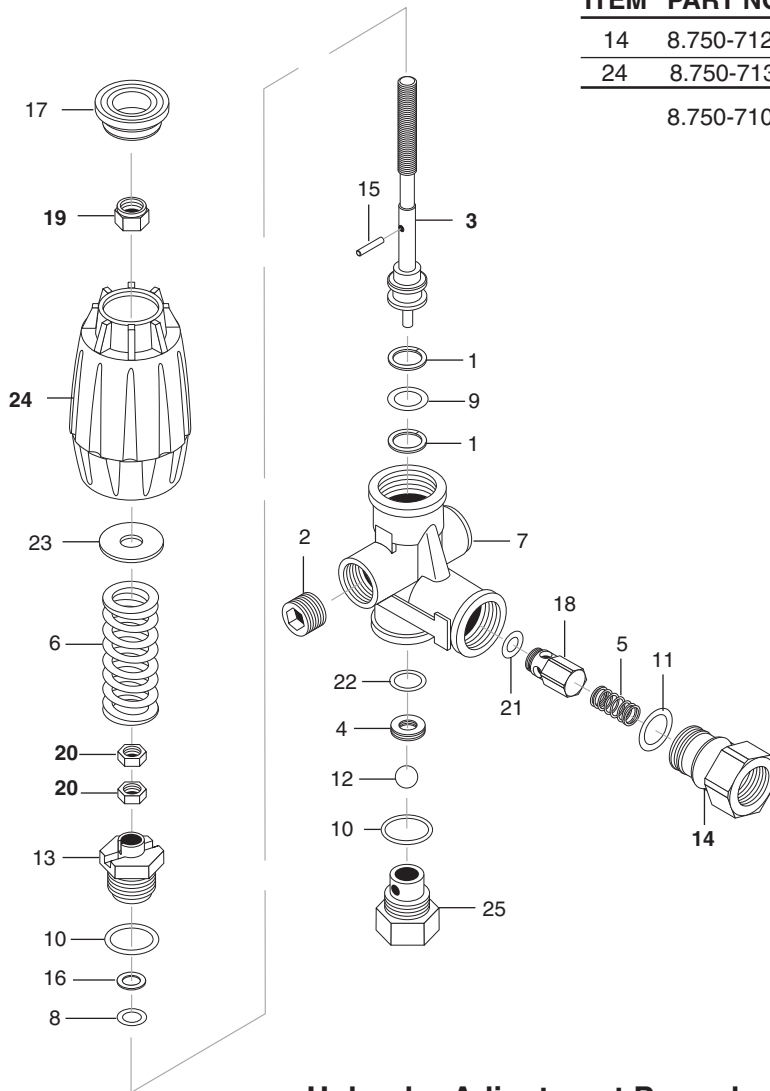

ITEM	PART NO.	DESCRIPTION	QTY
14	8.750-712.0	Outlet Fitting	1
24	8.750-713.0	Knob, Unloader	1
	8.750-710.0	Repair Kit, VRT3, 4500 PSI (Kit Items: 1, 4, 8-12, 16, 21-22)	

## Unloader Adjustment Procedures

1. Remove lock nut (Item 19).
2. Remove adjustment knob (Item 24).
3. Loosen the two (2) nuts (Item 20), move them upward on stem (Item 3) until you see 4 or more threads below the nut.
4. Re-attach adjusting knob (Item 24).
5. Start machine. Open the trigger of the spray gun. Increase pressure by turning adjustment knob (Item 24) clockwise until pressure is at the desired operating pressure.
6. Remove the adjustment knob (Item 24), tighten the lower nut (Item 20) tightly against the upper nut (Item 20). Re-attach adjustment knob (Item 24) and screw down until contact is made with the nuts (Items 20). Screw down lock nut (Item 19) onto the stem (Item 3) until the threads cut into the nylon insert of the lock nut (Item 19).

\*If adjustment knob (Item 24) **DOES NOT** make contact with upper nut (Items 20), remove adjusting knob (Item 24), re-adjust (raise) nuts (Items 20) on stem (Item 3) and re-attach adjustment knob (Item 24), then repeat step #6.

\*\*If adjustment knob (Item 24) **DOES** make contact with upper nut; release the trigger of the spray gun and watch the pressure gauge for the pressure increase ("spike"). This "spike" **SHOULD NOT** exceed 500 psi above the operating pressure. If "spike" pressure exceeds the 500 psi limit, remove the adjusting knob (Item 24) and re-adjust (lower) the nuts (Items 20) on the stem (Item 3). Re-attach the adjusting knob (Item 24), then repeat step #6.



**LANDA<sup>®</sup>**  
Kärcher Group

Form #8.913-910.0 • Revised 05/17 • Printed in U.S.A.