



2024

DISTRIBUTOR PRICE LIST

DISCOVER THE BRILLIANCE | Technologies for cleaning industrial wash water.





COMPLETE WASH WATER SOLUTIONS.

Since the late 1980s, Water Maze has been perfecting the art and science of wash water treatment. We have incorporated various technologies that are capable of: settling heavy solids, removing suspended solids; skimming free-floating oils; removing emulsified oils; bio-remediating organic matter; and reducing (evaporating) water. We provide systems for discharge, as well as for recycling water.



CONTENTS

THE WATER MAZE APPROACH	4	BIO-DIGESTION.....	45
SELECTION GUIDE	10	Universal Clarifier: Bio-Digester Option	46
Selection Guide Chart.....	12	PM-1000D	47
APPLICATION SOLUTIONS.....	14	EVAPORATION.....	48
Construction Equipment	15	HBG	49
Transportation Wash Water	16	WB	50
Marina Boat Wash Water.....	17	Evaporator Belt.....	51
Golf & Turf Wash Water.....	18	STORAGE / ADDITIONAL CAPACITY	52
Floor Scrubber Wash Water	19	Above-ground Cone-bottom Tanks.....	53
Industrial Metal Finishing	20	SOLIDS HANDLING	54
WATER CONTAINMENT	21	Pit Cleaner.....	55
Wash Pad Guidelines.....	22	Hydro Screen	55
Above Ground Portable Wash Racks.....	23	Sludge Container	55
In-ground Fiberglass Pit Systems	24	DEMUCKING	56
UNIVERSAL CLARIFIER OVERVIEW.....	25	Water Blaster.....	57
Internal Configuration Options	26	CONSUMABLES	58
External Configuration Options.....	28	Bio-nutrients.....	60
Universal Clarifier Configuration Check List	29	Clay & Filter Paper	60
Universal Clarifier System Concept Drawings	29	ACCESSORIES & PARTS	61
Equipment Room Guidelines	31	SPECIFICATIONS	72
OIL SEPARATION.....	32	Filter Capacities	72
ALPHA	33	Compatible Sump Pumps	72
Universal Clarifier: Coalescing Cones Option.....	34	Shipping Weights and Dimensions.....	73
Mop Skimmer.....	35	Comparison Matrix	74
HEAVY SOLIDS REMOVAL AND CHEMICAL TREATMENT.....	36		
Universal Clarifier: Tank-in-Tank Option	37		
Compact CoAg Module.....	38		
pH Permissive Control System	39		
FILTRATION.....	40		
REC-ZCF	41		
REC Series.....	42		
ZCF Filter Pac.....	43		
High Boy	44		

THE WATER MAZE APPROACH

Typically, multiple products and/or multiple water treatment technologies become part of the total solution. Only Water Maze offers such a complete range of products and technologies. Combined with our extensive network of local supporting dealers, Water Maze is your best partner for wash water and industrial water treatment systems. Incorrect selection of products and/or water treatment technologies can be a costly mistake. Equipment selection should involve a qualified application sales engineer that can assist and guide the buyer through the process.

Water Maze Applications Engineers will look at each application by asking three general qualifying questions:



1. What is in the water?

Water can have many different contaminants that each require different treatment methods to remove: free oil, emulsified oil, heavy solids, suspended solids, dissolved solids, and dissolved organic chemicals.



2. What is the demand for the application?

Determine how much water is generated that needs to be treated, as well as flow rates and hours of usage.



3. Where is the water going?

Determine if the water will be treated/ discharged, recycled/reused or reduced/ evaporated.



Manufacturing Excellence

All Water Maze products are built and tested in America. Our manufacturing center is ISO 9001 and 14001 certified. Every product is tested before shipping to ensure high quality and reliability.

SOLUTIONS

We manufacture the building blocks that are integrated into complete water treatment solutions. We tailor our wide array of technologies to each customer's application and requirements.



Engineering & Technical

Our team of design engineers and service technicians have decades of experience in industrial water processes. We have designed and installed thousands of installations across the country that are treating and recycling millions of gallons of water every day.

SYSTEM DESIGN

Every project is a partnership between the customer, Water Maze engineers, and your local dealer expert. We do not simply sell products — we provide integrated solutions designed to meet your needs.

WATER ANALYSIS

We provide a comprehensive evaluation of your wastewater and use that information to develop an optimized system designed to treat it to the standard of your application.



Expertise & Support

The Water Maze service network is available throughout North America. Trained technicians are available for start-up, service and ongoing operational support. From initial design consultations to after-sale support, we have expertise to assist every step along the way.

Water Maze treatment systems are designed to provide many years of reliable service with minimal repair and maintenance downtime. We are proud to have systems continuing to operate after twenty years. However, when you need us, our factory support hotline is staffed with experienced technicians. Local dealer service capabilities can have a technician, parts, and supplies on site quickly to keep your operation running.

INSTALLATION SUPPORT AND TRAINING

With experienced local dealer support, we can guide your team through the installation process, provide start-up services, and train your technicians to have your system operating efficiently starting on day one.

EVERY TREATMENT SYSTEM IS OPTIMIZED TO PRODUCE THE REQUIRED EFFLUENT QUALITY AT THE LOWEST OPERATING COST.

We evaluate treatment requirements against best available technologies and select the optimum combination to meet required objectives. Systems can be designed to permit reuse/recycle, discharge to sewer* or evaporation of your waste stream – often resulting in virtually zero-discharge systems.

How We Develop Your Solution

Goals & Treatment Needs



WATER SAMPLE ANALYSIS

Representative sample analysis, pollutants, concentrations, oils, solids, dissolved particles, organic compounds, metals.



SOLUTION DEVELOPMENT & PROPOSAL

Develop a project solution including detailed product specifications and site-specific drawings.



INSTALLATION & COMMISSION

On-site support for a smooth install and operators are ready to manage the process from day one.



ON-GOING SERVICE PARTNERSHIP

Supplying consumables, training new employees, support and maintenance.

*Subject to local regulations and permits

Pre-Treatment

All water treatment systems should include “adequate” pre-treatment. The definition of “adequate” may vary depending on the site specific application conditions and the physical and chemical properties of the influent water.

The primary objective of pre-treatment is to prepare the water for additional downstream treatment. For some applications, simply adjusting the pH of the water will effectively change the physical characteristics of the water and perhaps will provide easier downstream treatment. A well designed pit system that removes settleable heavy

solids will reduce the burden to downstream equipment from being overwhelmed. If changing or adding the pit system is not feasible, perhaps adding an above-ground cone-bottomed clarifier tank is an option.

For some applications, where there is an abundance of free-floating oils in the water, pre-treatment to remove excessive amounts of free-floating oils prior to addressing the emulsified oils may be required.

Oil / Water Separation

Oil/water separators are generally capable of separating free-floating oils, rather than chemically emulsified oils, or soluble oils from water. Many unaware buyers will request an oil/water separator, without knowing the physical characteristics of the oils as they exist in the water. This can result in a costly mistake.

Free-floating Oils



Are the oils free-floating?
Traditional oil/water separators are applied to applications where the oils are buoyant and floating on the surface.

Emulsified Oils



Are the oils chemically emulsified and dispersed within the water?
Instead of traditional oil/water separators, a “de-emulsifying” water treatment technology should be considered for your application.

Soluble Oils



Are the oils water soluble?
Traditional oil/water separators are not normally applied. Rather, reducing the water volume prior to off-site disposal (using evaporation technology) should be considered for treatment.

Coagulation / Flocculation

Advantages: Flocculation can produce exceptional water quality with minimal maintenance and can successfully treat broad ranges of waste streams

Coagulation/flocculation water treatment technology is used to remove suspended particles and/or emulsified oils. Particles are suspended due to natural ionic charges that are present in the water. For emulsified oils, the use of cleaning agents create similar ionic charges around oil droplets. In either case, these common charges create repelling forces to suspend matter.

Coagulation | Neutralizes the repelling charges and to allow the matter to gather (agglomerate). For most applications, coagulation can be accomplished by mixing a chemical coagulant into the water.

Flocculation | Creates an additional adhesion between the agglomerated matter by mixing a flocculent chemical into the water. Adds molecular weight to the matter, which enhances the separation and removal process of the contaminants from the water.

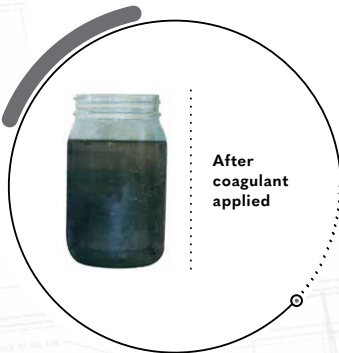

Mechanical Filtration

Mechanical Filtration is the removal of solids from water. Solids in water are normally classified and measured as either suspended (Total Suspended Solids – TSS), or as dissolved (Total Dissolved Solids – TDS). Water Maze offers products with filtration capabilities that range from 5 to 20 micron.

When selecting a mechanical filtration system, it is important to confirm: What are the water quality requirements for the intended use of the water? Does the selected filter or system remove enough of the particles to achieve the needed water quality requirements?

Factors to consider when selecting a system:

- Total spectrum (range) of particle sizes
- Total amount of particles contained in the water (e.g., percentage of total solids)
- Required maintenance by the filtration system
- Process flow rate requirements

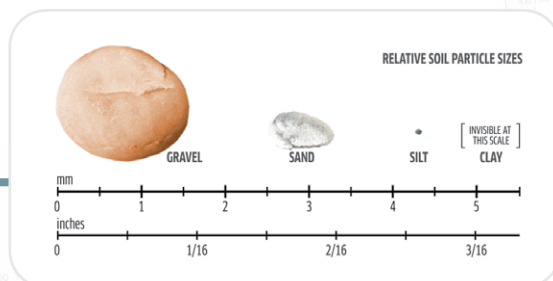

Modular Bioremediation

Advantages: Bioremediation can be user friendly, cost effective, and be a low cost method of treating certain types of water. However, if misapplied, bioremediation can result in poor water quality, malodorous conditions, and become an overall unpleasant experience for the end-user.

Bioremediation is the process of applying living organisms (microbes) for the purpose of breaking down organic carbon based molecules. The process renders the organic compounds into harmless carbon dioxide and water.

BioSystem products, in some cases, can be applied as a stand alone system. Typically bioremediation is a component within a system.

Water Maze BioSystem employs the latest aerobic bio-technology for treating broad range waste streams such as: water generated from washing golf and turf equipment; water from washing trucks and trailers; and wash water with emulsified hydrocarbons (oils).

As with all our systems, pre-treatment is also an important element to any bioremediation system.



ANALYSIS

Bioremediation applications require a base-level water analysis to assure that the elements for design criteria have been considered before a recommendation for a BioSystem can be determined.

Evaporation

Water volume reduction using evaporation technology can be an economical alternative to the high costs of off-site disposal of water, which can exceed \$1 USD per gallon. Evaporation costs can be a fraction of off-site disposal costs. Wastewater being hauled off-site is mostly water. Our evaporation systems may achieve up to a 95% volume reduction. This can translate into major costs savings and a quick return on investment for the purchase of the equipment.

Evaporator applications normally have smaller volumes of wastewaters with characteristics that are too complex and expensive for traditional treatment methods. The process of evaporation is a thermal exchange of heat into the body of water. Water Maze offers a variety of evaporators that employ different thermal transfer technologies that engage various power sources, natural gas (NG), liquid propane (LP), or electricity, to custom fit each solution.

CUSTOMERS THAT BENEFIT FROM EVAPORATORS:

- Have been paying for off-site wastewater disposal
- Want to reduce disposal cost by as much as 95%
- Want to reduce liability exposure related to off-site disposal
- May achieve a return on investment (ROI) within 2 years

CRITICAL ISSUES TO CONSIDER:

- The pH of the influent water should be balanced
- The influent water must not be flammable



ANALYSIS

Evaporator applications require a base-level water analysis to assure that the elements for design criteria have been considered before a recommendation for an evaporation can be determined.



Selection Guide

WATER MAZE APPLICATIONS ENGINEERS WILL LOOK AT EACH APPLICATION BY ASKING THREE GENERAL QUALIFYING QUESTIONS:

01



WHAT'S IN THE WATER?

- Each water treatment application will have different contaminants which will require different treatment strategies.
- Contaminants can include debris, fine suspended solids, oils, and dissolved chemicals.
- Get a good understanding of what processes are generating the waste stream to be treated.

02



HOW MUCH WATER?

- The amount of water generated and when it is generated will determine the size of the system required.
- Learn how fast water is generated. (gal/min)
- Learn how long water is generated. (gal/day or hrs/day)

03











WHERE IS THE WATER GOING?

- Different treatment strategies will be appropriate depending on the intended use of the water.
- Water Maze offers treatment options for water disposal, reuse, and evaporation.

Once these questions are answered, a Water Maze Applications Engineer will work with your team to specify treatment products, generate drawings, and provide startup support.

SELECTION GUIDE CHART

 1 What's in the water?	 SOLIDS		 SUSPENDED SOLIDS		
	 2 How much water?	 Heavy Settling Solids	 Debris & Floating Matter	 Inorganic	 Organic
 3 Where is the water going?					
PRE-TREATMENT TECHNOLOGY					
PRE-TREATMENT BELOW-GROUND					
Fiberglass Pit, Gratings, Covers	24	■	■		
Wash Pad & Pit Systems	22	■	■		
PRE-TREATMENT ABOVE-GROUND					
Steel Wash Racks	23	■	■		
CLT-300 / CLT 600 Tanks	53	■	■		
Self-Cleaning Screen	70		■		
pH Permissive (dual controller - up & down)	39				
HydroScreen	46		■		
PRIMARY TREATMENT TECHNOLOGY					
Alpha-1500D Oil/Water Separator	33				
UNIVERSAL CLARIFIER CLT-300 OR CLT-600					
pH Control	28			■	■
Coalescing with Oil/Water Separator (OWS)	35				
Belt-mop Skimmer (OWS)	35				
CoAgulation/Flocculation (integrated on CLT)	28 30			■	■
Internal Mixing Manifold (solids settling)	27	■		■	■
UV Ozone (odor control) – in lieu of BioSystem	28				■
Eofill for Bioremediation	27				■
Self-Cleaning Screen (inside CLT)	70		■	■	■
CoAgulation/Flocculation (Compact CoAg module)	28 30			■	■
POST TREATMENT TECHNOLOGY					
PM-1000D BioSystem (Bioremediation)	47				■
Filtration (IPF-20D or ZCF Media Filtration)	40			■	■
Water Evaporation (HBG and WB models)	48			■	

DISSOLVED SOLIDS		pH	OILS			METALS	VOCS
Inorganic	Organic	High / Low pH	Free-floating Oils	Emulsified Oils	Coolants / Soluble Oils	Metals	Volatile Organic Compounds
		■				■	
			■				
	■	■	■	■		■	
			■				
			■	■			
				■		■	
	■						
	■						■
				■		■	
■					■	■	■



Application Solutions

Construction Equipment

Type of Industry: Construction Company /
Machinery Dealer / Rental



The most common issue related to wash water generated from washing construction equipment is the potential for high volumes of dirt, as well as the high water velocity (i.e., water blasting, or water cannons). The second issue is the type of dirt (i.e., heavy dirt that will settle out quickly, clay solids that stay suspended for a long period of time, dirt with high amounts of organic matter). Washing mechanical repair items (i.e., engines, drive train, or hydraulic components) will also add oils (typically emulsified oils) into the list of contaminants.

Typical concerns and considerations

- Solids retention & removal: Designing a large pit system is a common mistake. Large pit systems will result in too much water that will become stagnant and will contribute to malodorous conditions (i.e., the water will become anaerobic). A well designed pit system should include the following:
 - Shallow water levels (i.e., solids will fall quicker to the bottom)
 - Sloped bottom with the water entry point at the shallow end of the slope
 - An easy method to clean out the accumulated solids
- Type of dirt & water velocity: Slowing down the water flow will result in assisting settling of the solids. High velocity flow rates (i.e., water cannon flow rates) will stir up the solids, and extend the settling rate of solids. This is especially true with clay based solids.
- Oils & greases: Commingling oils with dirt can change the classification of the dirt from landfill to a more regulated classification. We recommend that a separate wash station be established in these instances. Hot water pressure washing and/or the use of quick release soaps and detergents is recommended.

WATER MAZE SOLUTIONS

Description	Purpose	See Page #
Wash Pad Design	High dirt volumes	22 - 24
Pit Cleaner	Sludge removal	55
PM-1000D	Aeration / bioremediation of pit system	47
Water Blaster	Heavy solids removal (25 GPM @ 500 PSI)	57
Universal Clarifier	Solids removal for discharge / recycle	37
Filtration / Recycle Module(s)	Water Quality to meet operating requirements of pressure washer	40

Note: The above should be considered as general information for this application. It is important to remember that each application will vary in terms of waste water characteristics, flow rates, as well as water quality requirements of the treated water. For detailed information, refer to the Water Maze "Construction" target market brochure.

Transportation Wash Water

Type of Industry: Trucking / Truck Dealership



Most truck dealerships manually wash the exterior of new & used heavy duty trucks and trailers with hot water and detergents - capturing dirt and debris from regular use. They'll also perform truck repair, which includes degreasing of engine and drivetrain components - which can contain significant amounts of oil. Additional chemicals may be used to brighten metal components which will alter the pH of the water. With all these different processes potentially feeding a system, truck wash applications can be very diverse from system to system. Understanding your application is key to success.

Typical concerns and considerations

- Sewer discharge most ideal
- Recycling of wash water can be achieved
- Floor scrubber water and parts washer water should not be commingled with wash water (see evaporation)
- Components and options will vary by application

WATER MAZE SOLUTIONS

Description	Purpose	See Page #
Dry-type Trench Drains	Medium dirt volumes	22 - 23
Fiberglass Pit System	Free floating oil removal, gravity settling of solids	24
Hot Water Pressure Washer	Oils removal	-
Universal Clarifier	Pretreatment to discharge / recycle to pressure washer	37
Filtration / Recycle module(s)	Water Quality to meet operating requirements of pressure washer	40
HBG-30D Water Evaporator	Reduce water volumes that should be hauled off-site	49

Note: The above should be considered as general information for this application. It is important to remember that each application will vary in terms of waste water characteristics, flow rates, as well as water quality requirements of the treated water. For detailed information, refer to the Water Maze "Transportation" target market brochure.

Marina Boat Wash Water

Type of Industry: Boat Repair & Marina

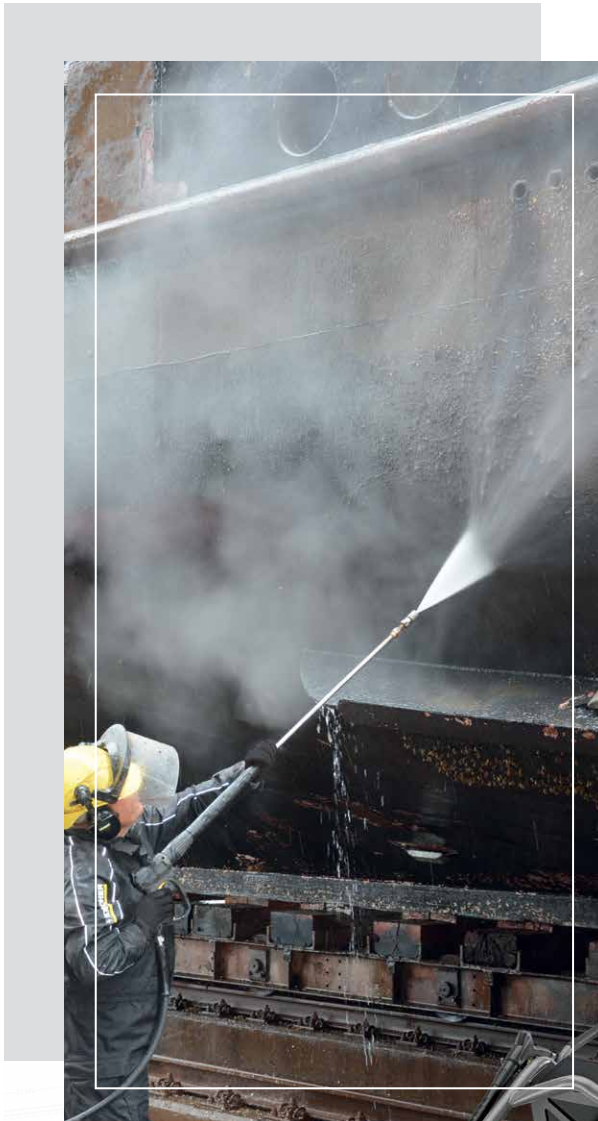

This application involves treating water generated from washing the hulls of pleasure craft and commercial vessels. There are three classifications: 1) Pleasure craft which travel within fresh water (i.e., lakes and rivers); 2) Pleasure craft which travel in sea water; 3) Dry dock repair of commercial vessels.

Solids retention: Cleaning the hulls of boats will involve the removal of barnacles and other organic matter that becomes attached to the hulls. Therefore, a basic dry-type trench drain (to extract the solids) and sump basin, or catch basin and sump basin is recommended.

Wash water contaminants (the hulls of boats): Since barnacles contain organic matter, the water can become malodorous due to anaerobic conditions. Therefore, it is important to minimize the amount of standing water in the pit system. Hulls made of ferrous metals will oxidize, and painted surfaces (including fiberglass hulls) incorporate metals (i.e., copper) that inhibits the growth of organic matter. Therefore, metals in the wash water will need to be addressed. Oils and greases are typically a minor issue. Invasive species such as Zebra Mussels in the North America water ways is a growing concern and can be addressed with filtration technologies.

Typical concerns and considerations

- Sewer discharge is most ideal.
- Recycling of wash water can be achieved
- Metals removal technology should be applied.
- Typically the wash pad / containment area is uncovered. Rainwater diversion will need to be designed into the pit system.

WATER MAZE SOLUTIONS

Description	Purpose	See Page #
Dry-type Trench Drains	Retain solids and reduce the amount of standing water	22- 23
Fiberglass Pit System	Minimize the growth of organic matter	24
Hot / Cold Pressure Washer		-
Universal Clarifier	Pretreatment to discharge / Recycle to pressure washer. Include MetalR+	37
Filtration / Recycle Module(s)	Water quality should be good enough for a pressure washer	40
HBG-30D Water Evaporator	To shrink down water volumes that should be hauled off-site	49

Note: The above should be considered as general information for this application. It is important to remember that each application will vary in terms of waste water characteristics, flow rates, as well as water quality requirements of the treated water. For detailed information, refer to the Water Maze "Marina" target market brochure.

Golf & Turf Wash Water

Type of Industry: Golf Courses

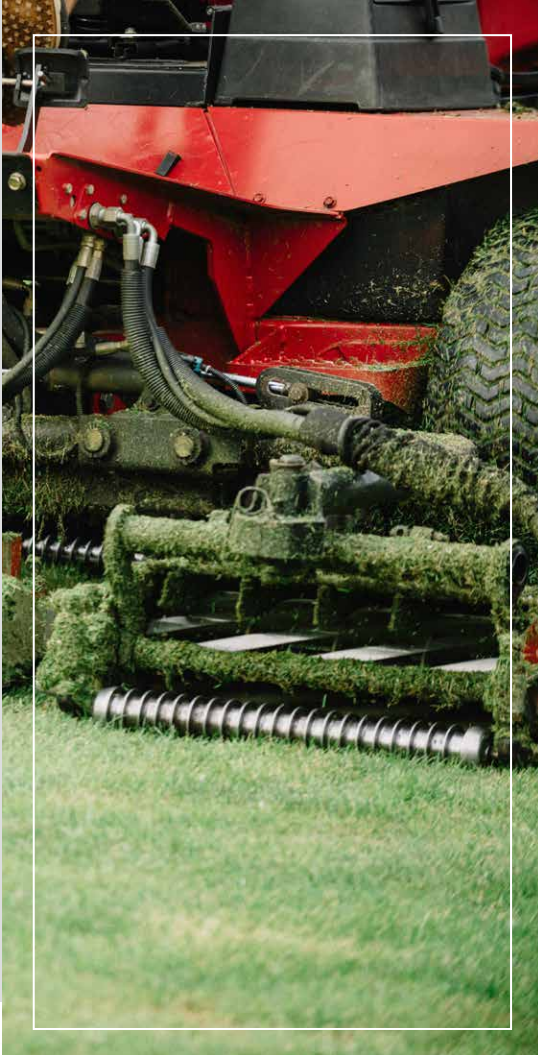

Golf courses need to wash their equipment to keep the mowers, tractors, and golf carts in top shape. Washing turf equipment increases the machinery life expectancy but the water picks up grass clippings and chemicals that the course managers can't have getting out of control. Oil, grease, fertilizers, herbicides, insecticides and pesticides in the wash water pose regulatory problems unless properly managed with quality water treatment. Biological treatment has become the industry standard for treating this water.

WATER MAZE SOLUTIONS

Description	Purpose	See Page #
Wash Pad / Rack	Retain wash water for treatment	23
Hydro Screen	Grass - small particle separator	55
Grass Cart	Haul off sludge cart	55
Feed Tank	Water storage for treatment	53
Universal Clarifier - Bio	Treatment of dissolved organics	46
PM-1000D	Aeration and nutrients	47
Collection Tank	Treated water storage	53

Note: The above should be considered as general information for this application. It is important to remember that each application will vary in terms of waste water characteristics, flow rates, as well as water quality requirements of the treated water. For detailed information, refer to the Water Maze "Golf & Turf" target market brochure.

Floor Scrubber Wash Water

Type of Industry: Machining / Manufacturing / Industry

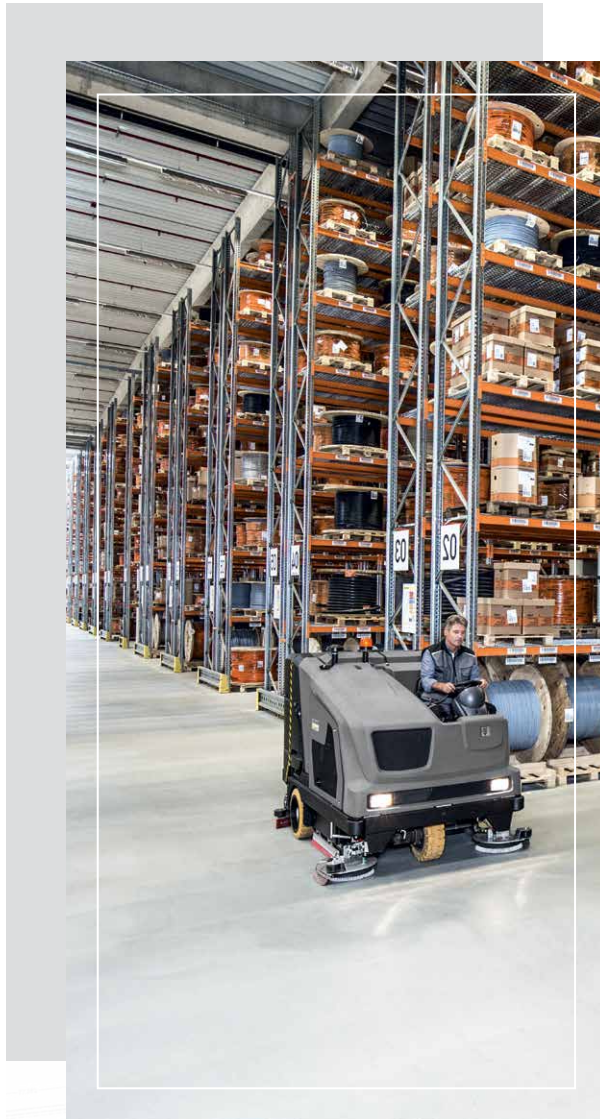

Due to the variety of floor scrubber applications, their wash water characteristics can vary. Therefore, a critical step will be to profile a representative water sample for each application.

Typical concerns and considerations

- Pretreatment to city sewer discharge is recommended, but might be prohibited due to the complex waste water characteristics.
- Metals removal technology might be required for discharge applications.
- Subject to the water volume, water evaporation could be part of the solution.

WATER MAZE SOLUTIONS

Description	Purpose	See Page #
Above Ground Sump / Screen	To receive water being discharged from a floor scrubber, screen out debris, and to filter water	23
Collection Tank (Cone-Bottom)	To collect water being pumped from the sump	53
Oil Skimmer (Optional)	To remove free-floating oils	35
Coagulation / Flocculation (Optional)	To remove emulsified oils prior to sewer discharge or prior to water evaporation	37
HBG-30D Water Evaporator	To reduce water volume prior to off-site disposal	49

Note: The above should be considered as general information for this application. It is important to remember that each application will vary in terms of waste water characteristics, flow rates, as well as water quality requirements of the treated water.

Industrial Metal Finishing

Type of Industry: Machining / Metal Finishing / Manufacturing



Metal finishing is a broad category within the manufacturing sector. The process of cleaning metal components includes the generation of water. Some examples:

- Spent machining coolants
- Parts washer fluids
- Phosphate and zirconium wash & rinse water

These waste streams will generally include contaminants that will exceed sewer discharge limits, so alternative methods of treatment and disposal will need to be used. In cases where the waste is so hazardous that it needs to be hauled offsite, evaporating the excess water to concentrate the waste can save cash.

Typical concerns and considerations

- Evaporation rates vary by equipment and application, but our evaporators can evaporate water at a cost on the order of \$0.10 / gal - whereas hauling hazardous waste can exceed \$1.00 / gal.
- Analysis of the water prior to installation is critical to understanding if prior treatment may be necessary and to assess overall system performance and safety.

WATER MAZE SOLUTIONS

Description	Purpose	See Page #
Water Analysis / Feasibility Report	This will provide operational guidance	49 - 51
pH Permissive System	Optional to control extreme pH ranges (+ or -)	39
Universal Clarifier	To provide pretreatment to below feed / storage tank (see list of technology options)	25
Feed / Storage Tank	Sized to contain up to 3 days of water	53
HBG-30D Water Evaporator	Reduce water volumes (up to 24 gallons / hour)	49
WB-50A Water Evaporator	Reduce water volumes (up to 60 gallons / hour)	50
WB-120A Water Evaporator	Reduce water volumes (up to 120 gallons / hour)	50

Note: The above should be considered as general information for this application. It is important to remember that each application will vary in terms of waste water characteristics, flow rates, as well as water quality requirements of the treated water. For detailed information, refer to the Water Maze "Industrial Metal Finishing" target market brochure.



Water Containment

Wash Pad Guidelines

IN-GROUND WASH PADS

Permanent in-ground wash pad design will make or break any wash water treatment system. The most successful water treatment systems will always have a well designed wash pad suited to their application. Careful consideration of solids loading, water volume, and system use are critical. A poor wash pad design will result in high solids and oil passthrough, excessive buildup or clogging, poor water treatment, and strong repulsive odors. Water Maze Applications Engineers are prepared to offer recommendations on proper wash pad design and maintenance for every application. Please contact Water Maze for assistance.

1 Pit Single Pad

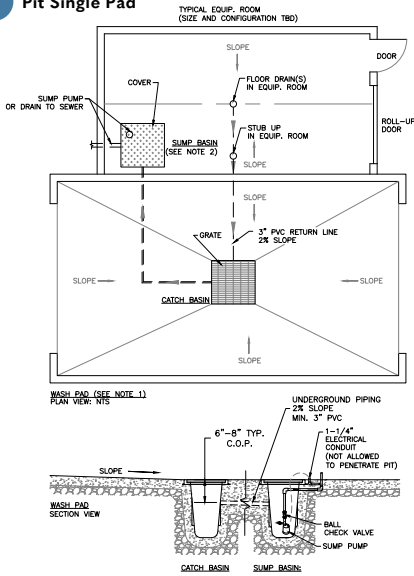

2 Pit Multi Pad

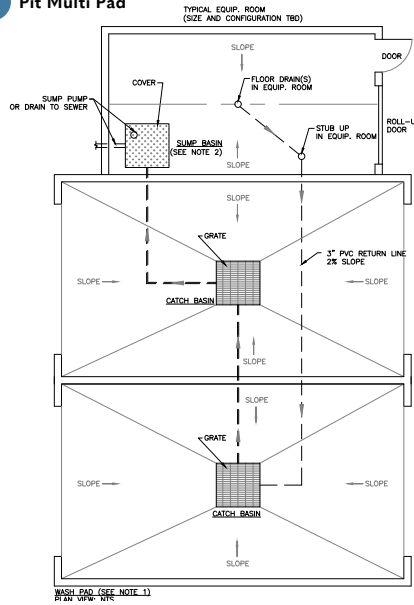

- The primary purpose of an in-ground pit system is to retain heavy settleable solids and debris that will impact the sump pump.
- Excessive amounts of water volumes in the pit system will create an anaerobic microbial environment (e.g. stagnant water) that will contribute to malodorous conditions in the wash area.

3 Pit Single Pad Inground Separator

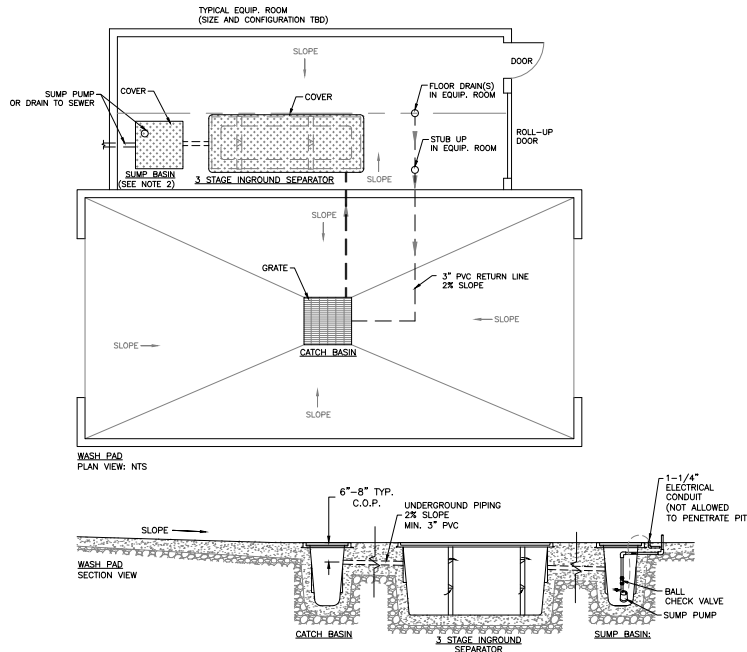

Above Ground Portable Wash Racks

Above ground wash racks can be a fantastic non-permanent solution to wash water capture. Water Maze offers modular above ground wash containment options configurable to any application from small parts to large machinery.

Drive-On / Back-Off and Drive-Through options available

Standards widths of 9, 12, 14, 16, 18, and 20-feet wide

Diamond plate deck surface + Flush surface for no trip hazards

Low profile modular design with maximum deck height 8.5-inches

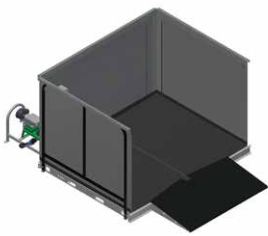

Drive-On / Back-Off
9' Wide

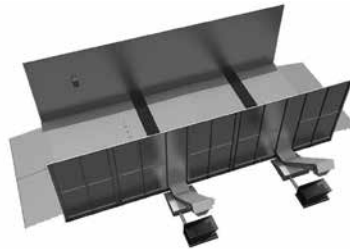

Conveyor Options Available for Automated
Solids Removal



Drive-Through
18' Wide



Drive-On / Back-Off
18' Wide



Drive-On / Back-Off with Optional Canopy
18' Wide

TECHNICAL DATA

Part No.	Description	Inside (L x W) Feet	Load Capacity (lbs)	Through Size Width (Feet)	Access Ramps	List Price
Special	Above-ground Steel Wash Rack	9 x 7	15,000	2	1 or 2	CALL
Special	Above-ground Steel Wash Rack	18 x 7	60,000	2	1 or 2	CALL

OPTIONAL ACCESSORIES

Part No.	Description	List Price
Special	Custom Deck Widths	CALL
Special	Integrated Undercarriage Rinse System: 60 GPM @ 100 PSI; includes 10' Spray Bar System with 10 Sub Surface Nozzle Pockets Embedded into One Set of Desk Sections and a Centrifugal Booster Pumping System with Enclosed Impellers	CALL
Special	Dual Diaphragm Pump Recovery System: Includes 2 Heavy Duty Suction Pumps; Hoses and Hose Connections from One End of Drain Trough to Pump Rack (available in single and dual options)	CALL
Special	Integrated Conveyor System: Automatically Removes Solids from the Center Trough System (available only for 18' wide or greater containment racks)	CALL
Special	Canopy Covers (available to fit all models)	CALL
Special	Treatment and Discharge Systems	CALL
Special	Recycle Systems	CALL

In-ground Fiberglass Pit Systems

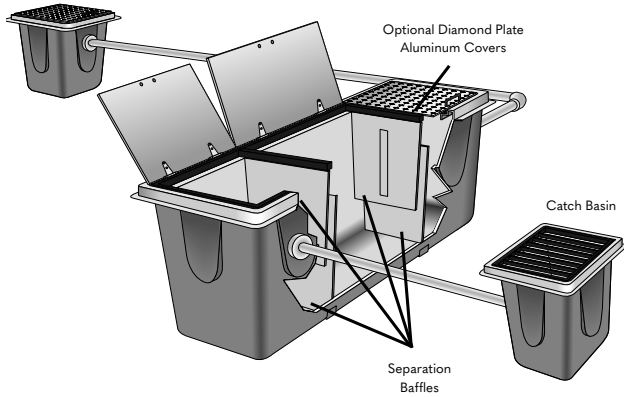

Water Maze offers in-ground fiberglass pits, which are easy to install. As compared to poured-in-place concrete pits that may eventually crack and allow water to leach into the ground, our fiberglass pits immersed into concrete can provide double containment. We offer three sizes of pits. The In-ground Separator (IGS) is uniquely designed with two sets of standing weirs that force solids to the bottom of the pit.

Below ground pre-treatment of wash water

Reinforced, pre-fabricated fiberglass

Easier and less expensive to install concrete

Chemically resistant fiberglass inhibits the growth of bacteria

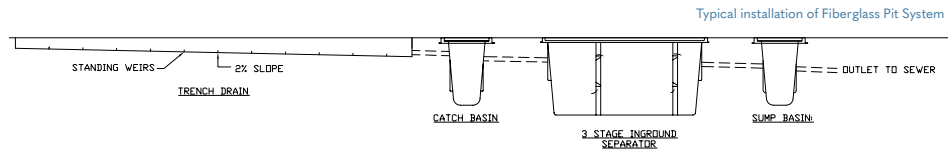

TECHNICAL DATA

Model	Part No.	Description	Material	Inside Dimensions (L x W x H) Feet	GPM	List Price
Collection Pit	1.043-499.0	In-ground Oil Separator Pit	Fiberglass	3 x 9 x 5	60	\$11,380.00
Sump / Catch Pit	8.709-333.0	In-ground Basin	Fiberglass	3 x 3 x 4.5	—	\$1,950.00
Sump / Catch Pit	8.709-334.0	In-ground Sump Pit	Fiberglass	2 x 2 x 3	—	\$1,125.00

OPTIONAL ACCESSORIES

Part No.	Description	List Price
COLLECTION PIT ONLY		
8.903-674.0	Cover, Hinged Aluminum, Diamond Tread Plate with Steel Tube Frame, 3' x 9'	\$2,490.00
8.903-673.0	Coalescing Grid Packs, 58 Plates, 1,700 sq ft Surface Area	\$3,140.00
CATCH BASIN ONLY		
8.903-678.0	Cover, Aluminum Diamond Tread Plate, 3' x 3'	\$910.00
8.903-677.0	Grating*, Hot Rolled Steel, 1/2" x 2" Flatbar, 1.5' x 3' (includes 2 grates)	\$1,660.00
SUMP PIT ONLY		
8.903-675.0	Cover, Aluminum Diamond Tread Plate with Steel Tube Frame, 2' x 2'	\$867.00
8.903-676.0	Grating*, Hot Rolled Steel 1/2" x 2" Flatbar, 2' x 2'	\$1,470.00

*Gratings meet H-20 truck load rating. Note: Sump pumps are sold separately.



Universal Clarifier Overview

Internal Configuration Options

The Water Maze Universal Clarifier is designed to be the platform around which your wash water treatment solution is built. The unit can be configured in one of four ways on the inside to best address your critical contaminants. External component options are tailored to each configuration to give you unmatched capability to tailor the perfect solution to your water treatment challenge.

This guide will walk you through the different internal configurations and options to make sure you know what's included with your system and can buy with confidence.

UNIVERSAL CLARIFIER: NATURAL CLARIFIER TANK

The standard no-frills clarifier configuration. This is the basic shell that all forms of the Universal Clarifier are built around. Cylindrical cone bottom tank available in 300 and 600 gallon capacities. Fully removable top for easy access inside the body of the clarifier. Perfect for use as a holding tank where periodic purging of settleable solids is necessary. For more detailed information, refer to page 53.

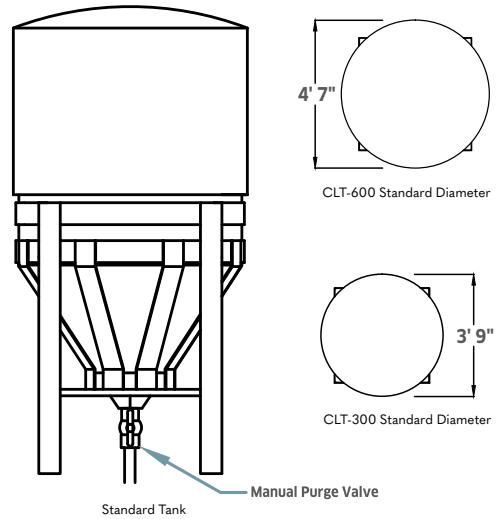

UNIVERSAL CLARIFIER: COALESCING CONES

The Coalescing Cone configurations add a set of internal cones to the Natural Clarifier format.

These cones direct the flow of dirty water through the cone stack and force free oil to agglomerate into larger drops as the water moves up through the clarifier. These larger drops of oil will separate more readily from the water and float to the top, where it can be skimmed off and separated. The treated water is pulled off below the oil rich surface. Additional cones can be installed for applications where oil concentrations tend to be higher. For more detailed information, refer to 34.

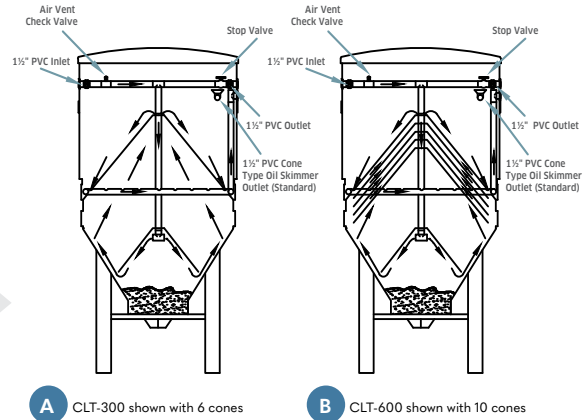

- A** 6 Coalescing Cones | 4 more cones can be added to the included 2 cones with the CLT-300.
- B** 10 Coalescing Cones | 8 more cones can be added to the included 2 cones with the CLT-600.

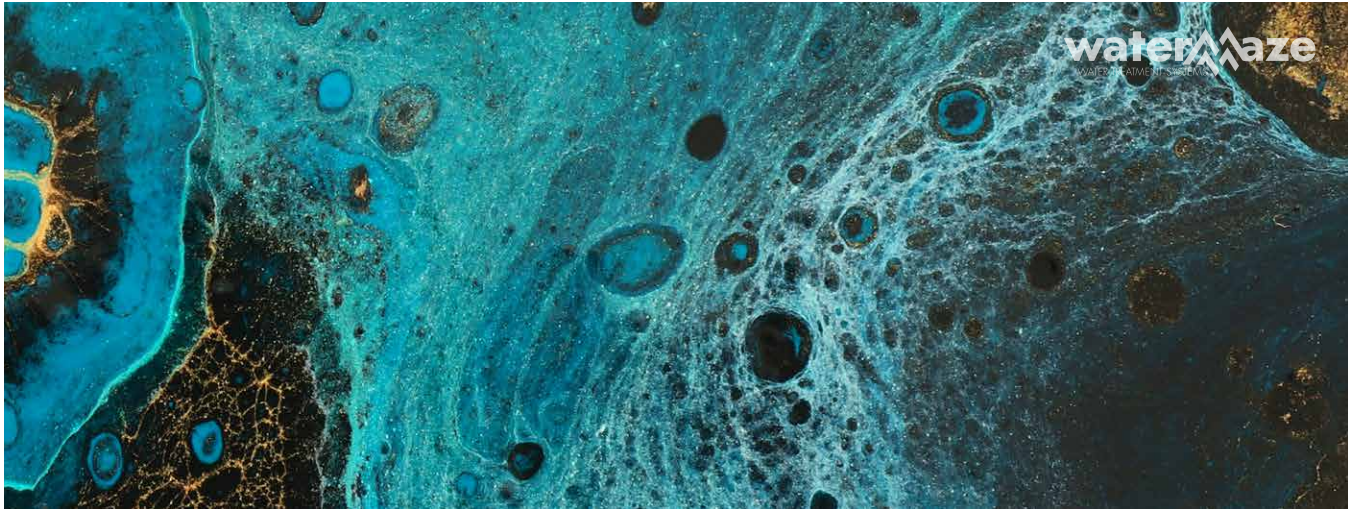

03

UNIVERSAL CLARIFIER: TANK-IN-TANK

The Tank-in-Tank configuration adds a small mixing chamber inside the body of the clarifier. This configuration is used exclusively for solids removal when chemicals have been added upstream of the clarifier and need to be gently mixed to fully react. By the time the water flows out the bottom of the smaller tank, the chemicals have flocculated to solids into larger clumps which will settle quickly to the bottom of the clarifier and allow the treated water to flow out the top. For more detailed information, refer to 37.

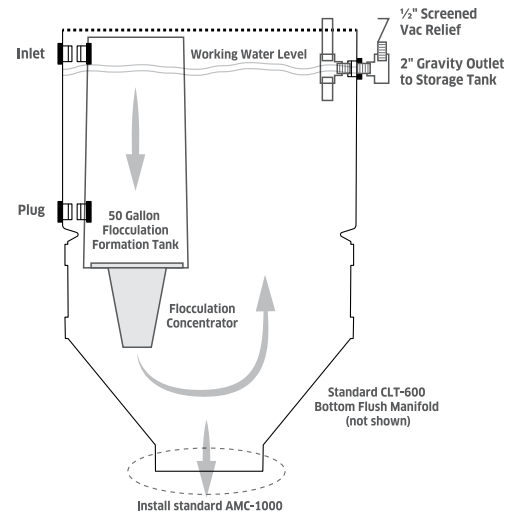

04

UNIVERSAL CLARIFIER: BIO-DIGESTER

Bio-digestion is the best way to treat dissolved organic chemicals in your water. To convert the Universal Clarifier into an aggressive bioreactor, we load it with high surface area fill material that allows the microbes to establish high concentration and activity levels in the clarifier. We also connect a PM-1000D aeration and recirculating system to manage feeding the microbes the necessary amount of air and nutrients to allow them to thrive and chew up your contaminants as quickly as possible. For more detailed information, refer to 46.

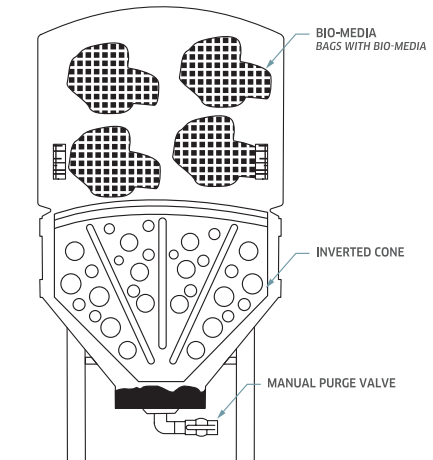

External Configuration Options

Once you have determined the necessary internal configuration of your Universal Clarifier, you will need to work with your Water Maze Applications Engineer to determine what external controls and chemicals will be necessary for your application.

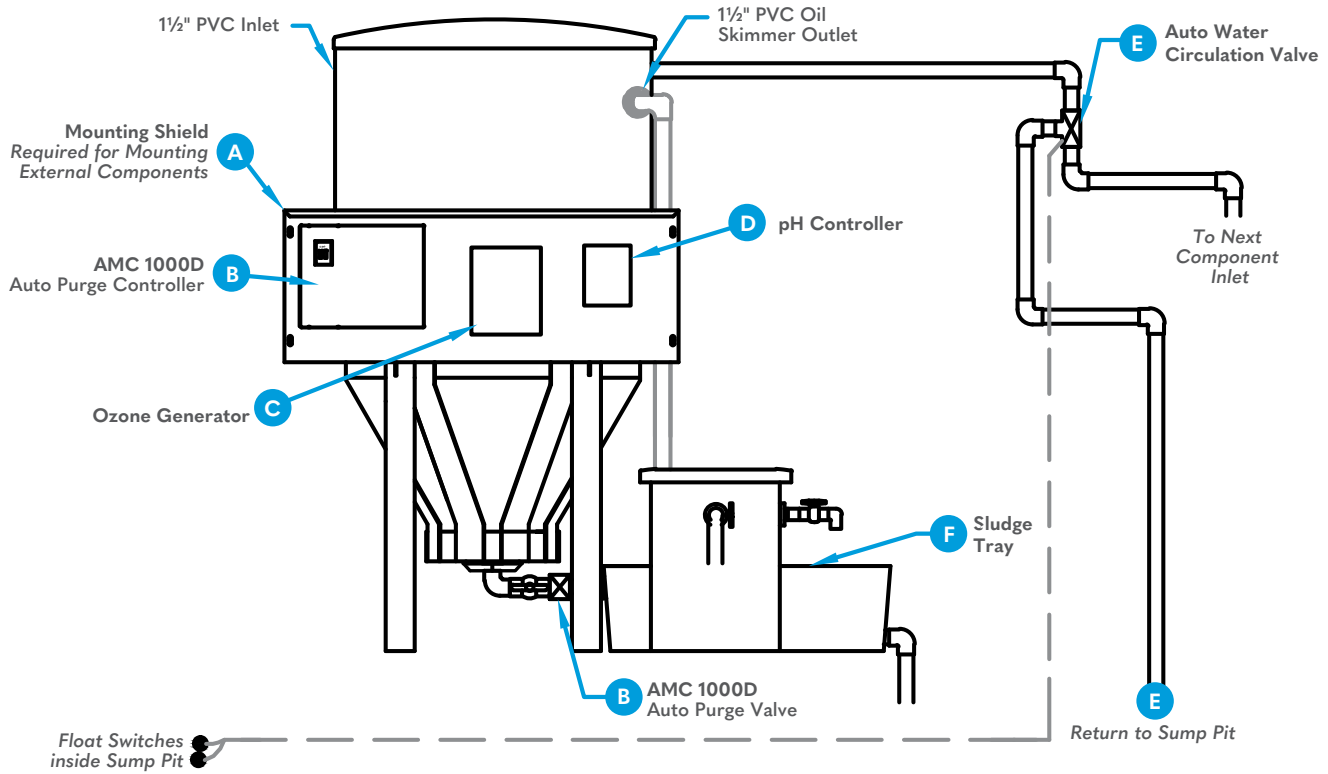

- A Mounting Shield** A simple way to mount external options, this bracket and shield is required when selecting any combination of options B–F.
- B AMC-1000D Auto Purge Controller** Control the AMC 1000D Auto Purge Valve. (highly recommended).
INCLUDES: Controller Housed in a NEMA Panel, Timers, and Air-actuated Purge Valve.
Utility Requirements: Compressed air (3 cfm @ 85 PSI activated), and 120 volt @ 3 amps.
- C Ozone Systems** Creates ozone and mixes it for sterilization of water.
INCLUDES: Circulation Pump, Timer, Mazzei Injector, and Manifold.
Utility Requirements: 120 volt @ 9 amps.

- D pH Control System** Controls pH of the water with a peristaltic pump.
INCLUDES: Controller with Inline Manifold with Probe and Injector, Peristaltic Chemical Feed Pump with Flow Switch
Utility Requirements: 120 volt @ 3 amp.
- E Auto Water Discharge / Circulation Valve System** Allow water to flow (24/7) back to the pit system reducing stagnant water issues.
Utility Requirements: 120 volt @ 1 amp.
- F Sludge Tray** Dewatering sludge tray with lid; stainless steel riser; and 5 sludge bags (supplied as a loose item).

Universal Clarifier Configuration Check List

Description	Item #		Specifications
OPTION 1 Select Tank Size - Select one	CLT-300	CLT-600	
CLT-300 - 300-gallon Cone-bottom tank , cradle, and lid	1-300	—	OWS up to 10 GPM, CoAg up to 8 GPM
CLT-600 - 600 gallon Cone-bottom tank , cradle, and lid	—	1-600	OWS up to 30 GPM, CoAg up to 16 GPM
OPTION 2 Select Oil Coalescing / Separator Cones			
CLT-300 - Additional 4 cones (ref above 3B-300)	4A-300	—	Also select 3B-300
CLT-600 - Additional 8 cones (ref above 3B-600)	—	4B-600	Also select 4B-600
Select Oil Skimmer - if applicable (For removal of free-floating oils)			
CLT-300 - with Belt-Mop skimmer w/ oil decanter	3A-300	3A-600	120 volt @ 9 amps (separate 120V circuit required)
CLT-300 - with Funnel skimmer, 2 cones, oil decanter	3B-300	3B-600	
OPTION 3 Select Internal Settling Manifold - For solids settling, as well as settling of flocculated matter			
CLT-300 / CLT-600 internal tank-in-tank design	2-300	2-600	
OPTION 4 Select Bio-digester			
Bio-digester package (CLT-600 only)	—	5-600	
Select External Options			
Mounting shield - for installing electrical control panels	7A-300	7A-600	
AMC-1000D Auto-purge system installed. <i>Compressed air required</i>	7B-300	7B-600	120 volt, @ 3 amps, 4 cfm @ 85 psi
UV Ozone system with circulation pump and timer	7C-300	7C-600	120 volt, 9 amps
pH Controller system	7D-300	7D-600	120 volt, 3 amps
Integrated Chemical Coagulation /Flocculation system	7E-300	7E-600	120 volt, 10 amps
MetalR+ Chemical injection added to above CoAg sys	7F-300	7F-600	
Auto-water Discharge / Circulation valve (not recommended with CoAg)	7G-300	7G-600	120 volt, 3 Amps
Sludge Tray / dewatering tray with lid, stainless-steel riser, 5 bags	8.906-478.0		

Universal Clarifier System Concept Drawings

01 Universal Clarifier System with Coalescing Cones and Funnel Skimmer

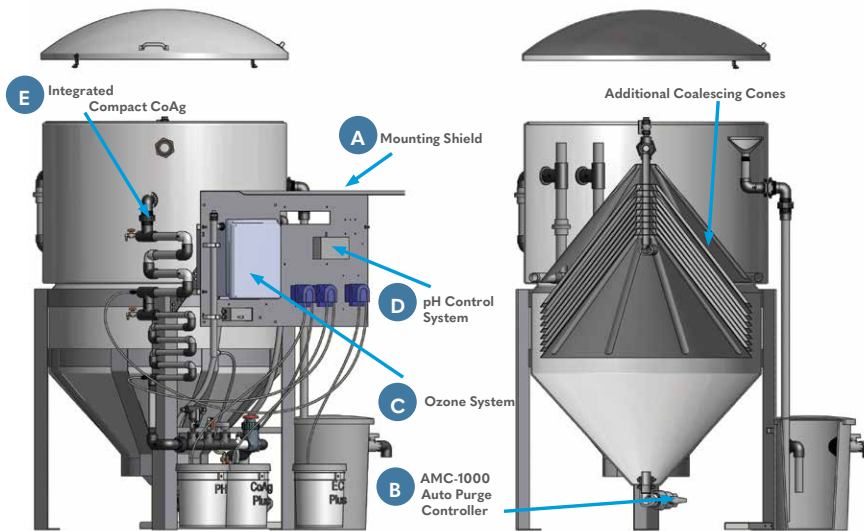

- A Mounting Shield** A simple way to mount external options, this bracket and shield is required when selecting any combination of options B–F.
- B AMC-1000D Auto Purge Controller** Control the AMC 1000D Auto Purge Valve. (highly recommended).INCLUDES: Controller Housed in a NEMA Panel, Timers, and Air-actuated Purge Valve. *Utility Requirements: Compressed air (4 cfm @ 85 PSI activated), and 120 volt @ 3 amps.*
- C Ozone Systems** (for the purpose of odor control): consists of an ozone generator, circulation pump, manifold with mazzei injector, and control panel with timer. *Utility Requirements: 120 volt @ 9 amps.*
- D pH Control System** Controls pH of the water with a peristaltic pump. Includes: Controller with Inline Manifold, pH Probe and Injector, Peristaltic Chemical Feed Pump with Flow Switch. *Utility Requirements: 120 volt @ 3 amp.*
- E Integrated Compact CoAg** Integrates the same chemical coagulation / flocculation technology as stand-alone Compact CoAg module INCLUDES: Enhanced External Mixing Manifold, Chemical Feed Pumps, and Control Panel Housed in a NEMA Box

Universal Clarifier System Concept Drawings (Cont.)

02 Universal Clarifier System with Belttop Skimmer Integrated CoAg and Mixing Chamber

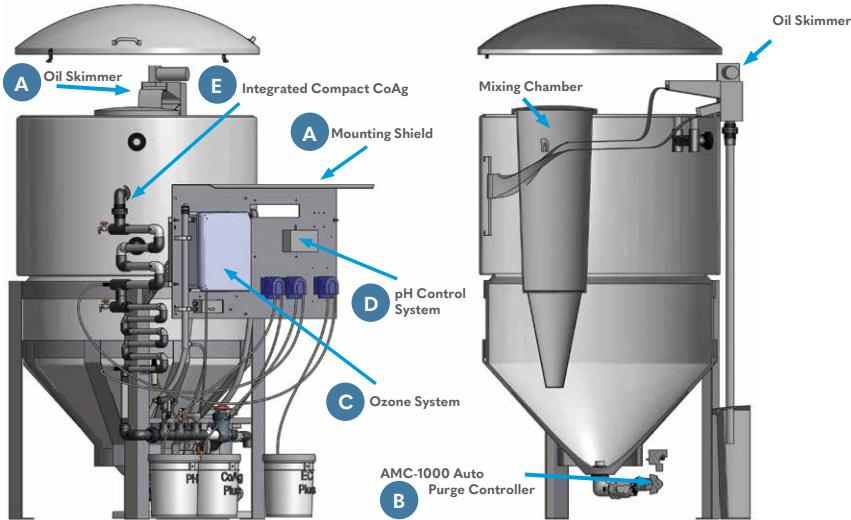

A Mounting Shield A simple way to mount external options, this bracket and shield is required when selecting any combination of options B–F.

B AMC-1000D Auto Purge Controller Control the AMC 1000D Auto Purge Valve. (highly recommended). INCLUDES: Controller Housed in a NEMA Panel, Timers, and Air-actuated Purge Valve. *Utility Requirements: Compressed air (4 cfm @ 85 PSI activated), and 120 volt @ 3 amps.*

C Ozone Systems (for the purpose of odor control): consists of an ozone generator, circulation pump, manifold with mazzei injector, and control panel with timer. *Utility Requirements: 120 volt @ 9 amps.*

D pH Control System Controls pH of the water with a peristaltic pump. Includes: Controller with Inline Manifold, pH Probe and Injector, Peristaltic Chemical Feed Pump with Flow Switch. *Utility Requirements: 120 volt @ 3 amp.*

E Integrated Compact CoAg Integrates the same chemical coagulation / flocculation technology as stand-alone Compact CoAg module INCLUDES: Enhanced External Mixing Manifold, Chemical Feed Pumps, and Control Panel Housed in a NEMA Box.

03 Universal Clarifier System with Coalescing Cones with Funnel Skimmer

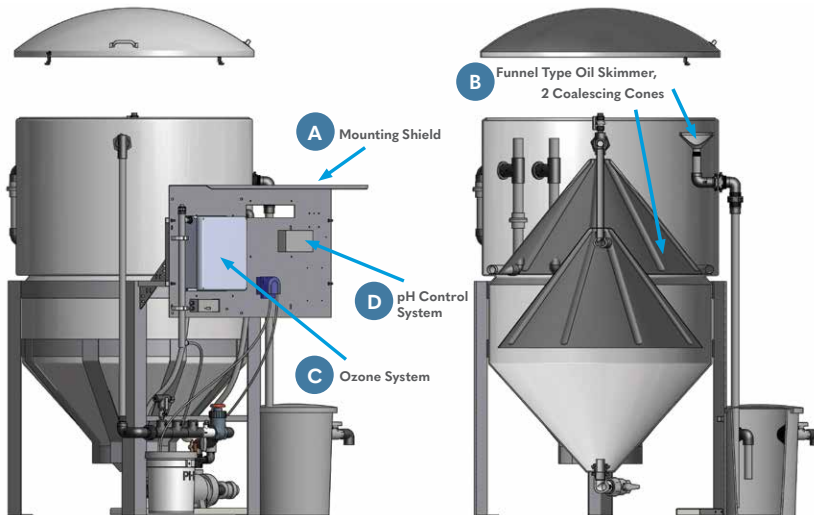

F MetalR+ Chemical Injection System* Utilized when applying MetalR+ chemical for removal of metals. (included with Integrated Compact CoAg) INCLUDES: Chemical Feed Pump; Injector, and Feed Port in the above Piping Manifold.

*Not shown in drawing.

Equipment Room Guidelines

A properly designed equipment room will consider and/or incorporate the following:

- Allow room for water treatment equipment plus site and owner equipment (pressure washers, compressors, etc.)
- Electrical and control panels require 30" clearance
- 18-20" maintenance access clearance around equipment recommended
- Request equipment detail drawings for equipment specifications (size, utility requirements, electrical/control panel locations, etc.)
- Floor should slope towards floor drains to contain any spillage
- A Stub Up should be available for overflow to return to pit or trench and discharge to waste or sewer
- Door should be sized to allow equipment move-in
- Ventilation: Required top and bottom (based on specific equipment requirements)

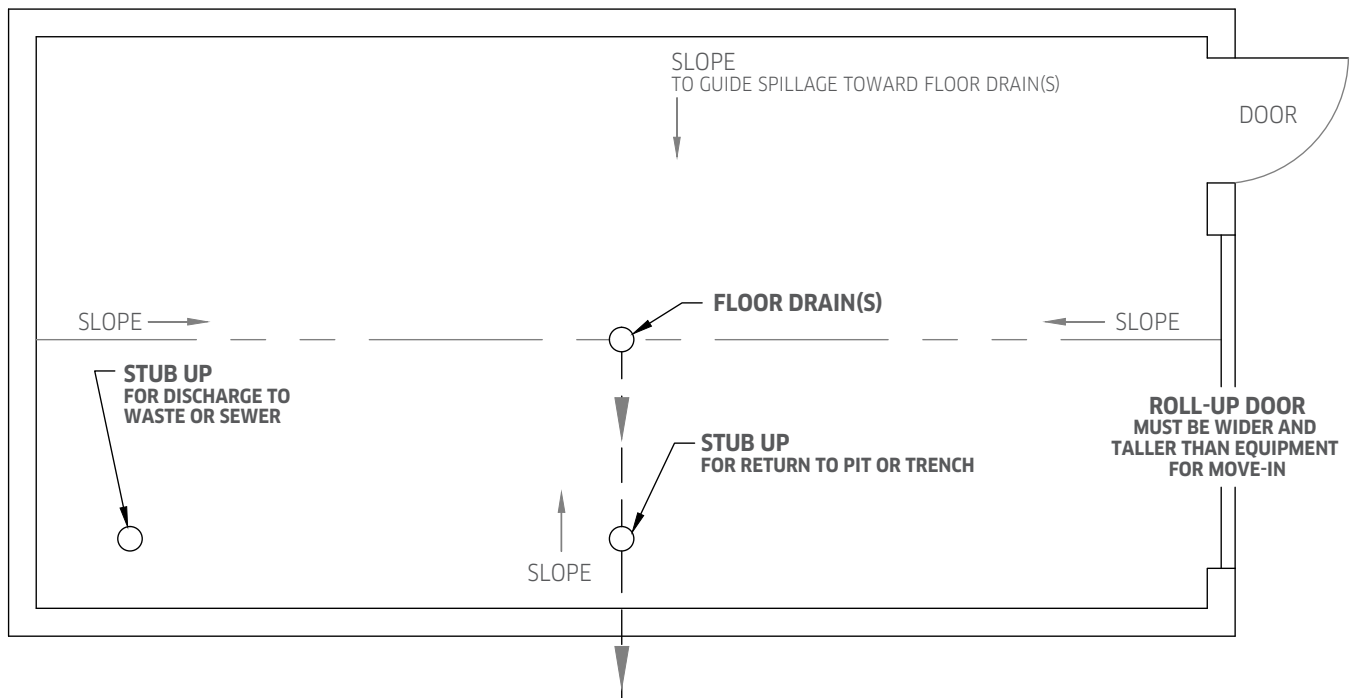

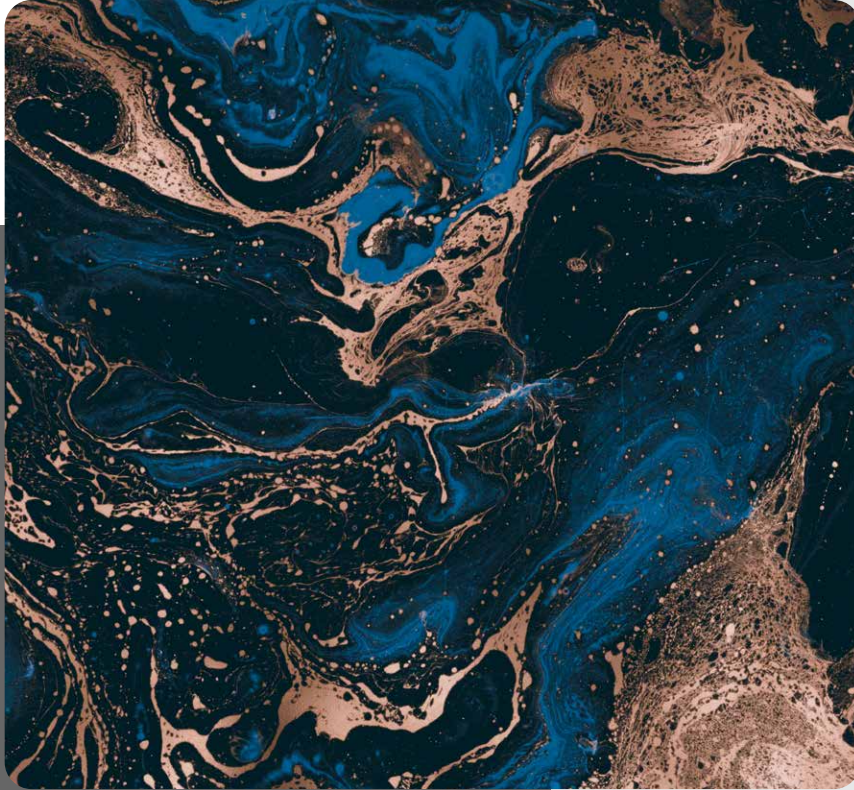

Oil Separation

ALPHA



The ALPHA-1500D model is a highly effective above-ground oil/water separator and is designed to discharge wash water at rates of up to 15 GPM. The ALPHA-1500D incorporates: a low-profile stainless steel tank; stainless steel baffles positioned for optimizing the water flow; proprietary coalescing “Maze” grids that maximize the oil coalescing process; ultra-violet ozone generator for odor control; automatic oil skimming and decanting; NEMA control center for automatic operation.

Up to 15 GPM

125-gallon stainless steel tank

Ultra-violet ozone generator uses special mixing procedure to ensure up to 99% contact of bacteria-killing ozone in wash water

Stainless steel baffles direct water flow for optimum treatment

Automatic oil removal and disposal

Specially designed sheen filter polishes the water before discharge

Water-resistant control box for automatic operation of pumps

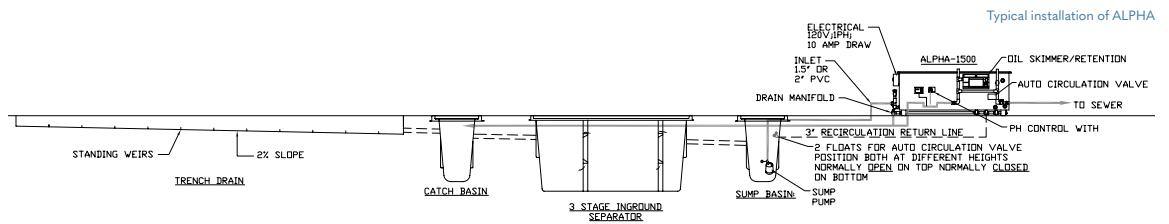

TECHNICAL DATA

Model	Part No.	Description	Coalescing Area	Capacity (gal)	Flow GPM	Voltage	Phase	AMPS	List Price
ALPHA-1500D	1.103-401.0	Above-ground Separator	500 Sq Ft	125	1 – 15	120	1	10	\$18,778.50

OPTIONAL ACCESSORIES

Part No.	Description	List Price
8.903-694.0	Auto-Water Discharge † (automatically switches between recycle and discharge modes)	\$1,535.00
8.903-647.0	ORP/pH Digital Controller, Model 250, 2 Pumps†	\$6,370.00
8.913-332.0	Lid, Aluminum	\$613.00

† Factory Install Only

Universal Clarifier: Coalescing Cones Option



CLT-600 Special



Inside of CLT-600 Special with Belt-Mop Skimmer

The Coalescing Cone configurations add a set of internal cones to the Natural Clarifier format. These cones direct the flow of dirty water through the cone stack and force free oil to agglomerate into larger drops as the water moves up through the clarifier. These larger drops of oil will separate more readily from the water and float to the top, where it can be skimmed off and separated. The treated water is pulled off below the oil rich surface. Additional cones can be installed for applications where oil concentrations tend to be higher.

4 more cones can be added to the included 2 cones with the CLT-300

8 more cones can be added to the included 2 cones with the CLT-600

TECHNICAL DATA

Model	Part No.	Description	Stand	Capacity (Gal)	Flow GPM	List Price
CLT-600	1.103-435.0	Modular Clarifier System Base Unit	■	600	1 - 30	CALL
CLT-300	1.103-434.0	Modular Clarifier System Base Unit	■	300	1 - 15	CALL

MODULAR CLARIFIER COALESCING CONES OPTION

Part No.	Base Unit	Description	List Price
3A	600, 300	Belt Mop Skimmer, 120 V/6 Amp, with Oil Decanter Container (CLT-600, -300, or -150)	\$9,650.00
7B	600, 300	AMC-1000D Auto-purge System (4CFM @ 85 PSI), 120 V/2 Amps **	\$3,110.00
7C	600, 300	UV Ozone System with circulation pump and timer, 120 V/9 Amps **	\$5,050.00
7D	600, 300	pH (only) Controller with one peristaltic pump electrically interfaced with the infeed pump / sump pump circuit †	\$4,910.00
7G	600, 300	Auto-water Discharge/Circulation Valve System, 120 V/2 Amps **	\$1,610.00
8.906-478.0	600, 300	Sludge Tub with Lid	\$662.00
CLT-600 ONLY			
7A	600	600-gallon Mounting Shield †	CALL
3B	600	Coalescing cones (2) with Funnel Oil Skimming, with Oil Decanter Container	\$2,540.00
4B	600	8 Additional Coalescing Cones (for a total of 10)	\$1,995.00
CLT-300 ONLY			
7A	300	300-gallon Mounting Shield †	CALL
3B	300	Coalescing cones (2) with Funnel Oil Skimming, with Oil Decanter Container	\$2,250.00
4A	300	4 Additional Coalescing Cones (for a total of 6)	\$940.00

† Factory Install Only. * Requires Rain Guard and Bracket option. NOTE: Sump pumps sold separately. Consult CL Quick Start Guide for full system options. Extended lead times apply to all orders placed through our Specials Department.

Mop Skimmer

(Free Floating Oils)

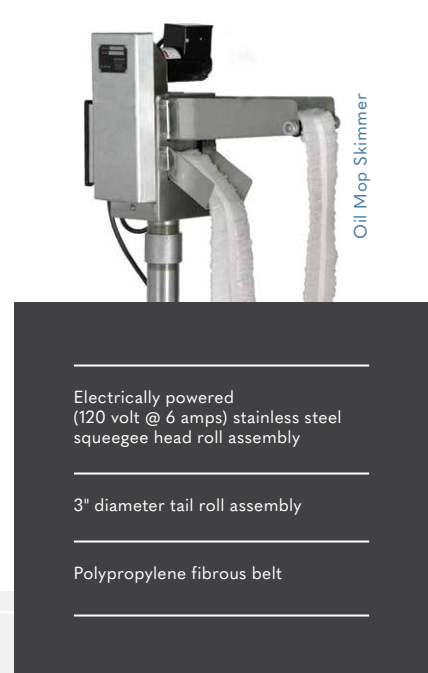
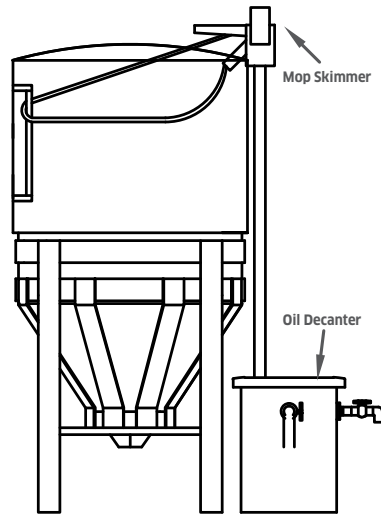

A workhorse for oil skimming requirements. Mop skimmers recover floating oil from the water surface quickly and easily. One of the two ways to remove free-floating oil are available for the CLT-300 or CLT-600 modules. Electrically powered (120 volt @ 6 amps) stainless steel squeegee head roll assembly and 3" diameter tail roll assembly with polypropylene fibrous belt.

Note: Skimmers include a 26-gallon oil decanter container with internal piping.

TECHNICAL DATA

Model	Part No.	Description	Capacity (gal)	Voltage	AMPS	List Price
Belt Mop Skimmer	Special	Oil Skimming machine	26 gal	120	6	\$8,000.00

OPTIONAL ACCESSORIES

Part No.	Description	List Price
Special	Belt Mop per foot	\$55.00
Special	Tail Roller 24"	\$490.00

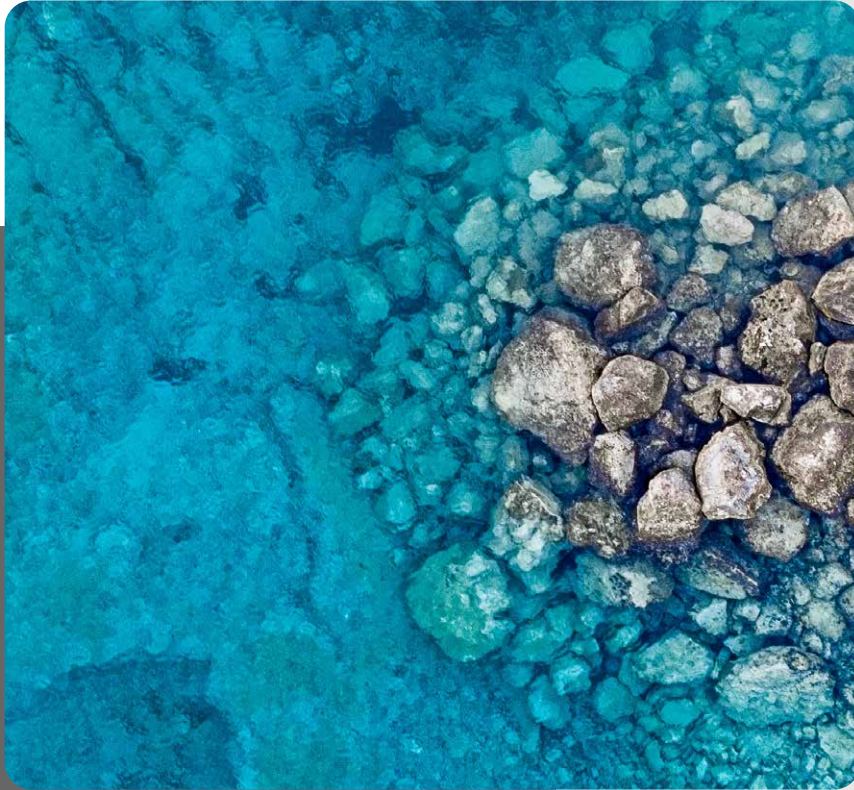

Heavy Solids Removal and Chemical Treatment

Universal Clarifier: Tank-in-Tank Option



- Enhanced external mixing manifold
- Chemical feed pumps
- Control panel housed in a NEMA box

The Tank-in-Tank configuration adds a small mixing chamber inside the body of the clarifier. This configuration is used exclusively for solids removal when chemicals have been added upstream of the clarifier and need to be gently mixed to fully react. By the time the water flows out the bottom of the smaller tank, the chemicals have flocculated to solids into larger clumps which will settle quickly to the bottom of the clarifier and allow the treated water to flow out the top.

TECHNICAL DATA

Model	Part No.	Description	Stand	Capacity (Gal)	Flow GPM	List Price
CLT-600	1.103-435.0	Modular Clarifier System Base Unit	■	600	1 - 30	CALL
CLT-300	1.103-434.0	Modular Clarifier System Base Unit	■	300	1 - 15	CALL

MODULAR CLARIFIER TANK IN TANK OPTION

Part No.	Base Unit	Description	List Price
7B	600, 300	AMC-1000D Auto-purge System (4CFM @ 85 PSI), 120 V/2 Amps ^{†*}	\$3,110.00
7C	600, 300	UV Ozone System with circulation pump and timer, 120 V/9 Amps ^{†*}	\$5,050.00
7E	600, 300	Integrated Compact CoAg (in lieu of stand-alone Compact CoAg module) [‡]	\$9,360.00
7F	600, 300	MetalR+ Chemical Injection Package (option to be used only with CoAg modules) [‡]	\$1,270.00
7D	600, 300	pH (only) Controller with one peristaltic pump electrically interfaced with the infeed pump / sump pump circuit [‡]	\$4,910.00
7G	600, 300	Auto-water Discharge/Circulation Valve System, 120 V/2 Amps ^{†*}	\$1,610.00
8.906-478.0	600, 300	Sludge Tub with Lid	\$662.00
CLT-600 ONLY			
7A	600	600-gallon Mounting Shield [‡]	CALL
2-600	600	CoAg Mixing Chamber (inside CLT-600 tank)	\$845.00
CLT-300 ONLY			
7A	300	300-gallon Mounting Shield [‡]	CALL
2-300	300	CoAg Mixing Chamber (inside CLT-300 tank)	\$845.00

[‡] Factory Install Only. ^{*} Requires Rain Guard and Bracket option. NOTE: Sump pumps sold separately. Consult CL Quick Start Guide for full system options. Extended lead times apply to all orders placed through our Specials Department.

Compact CoAg Module



The Compact CoAg Module employs chemical coagulation and flocculation water treatment technology to enhance and speed up the process of removing suspended solids and most types of emulsified oils. This product utilizes a patented process for applying and mixing proprietary blends of chemical coagulant (CoAg+) and flocculant (EC+) to effectively de-emulsify oils and to agglomerate suspended solids. The Compact CoAg Module is typically combined with a separator/final blending tank that has unique internal piping, along with an auto-purge system that results in very little standing water within the system at the end of the day.

Four mixing chambers and chemical injection ports

Integrated electrical control center with automatic shut-down system

Skid mounted steel chassis

TECHNICAL DATA

Model	Part No.	Description	Coagulation	Flocculation	Flow GPM	Voltage	Phase	AMPS	List Price
Compact CoAg	1.103-510.0	Compact CoAg Module	Chemical	Chemical	1 – 20	120	1	14	\$9,823.45

OPTIONAL ACCESSORIES

Part No.	Description	List Price
8.921-729.0	pH (only) Controller with one peristaltic pump electrically interfaced with the infeed pump / sump pump circuit †	\$5,375.00
8.921-730.0	AMC-1000D, Auto-Purge System † Includes: mounting of control center on the chassis of the Compact CoAg and the air actuated auto-purge valve supplied as a loose item (compressed air required 4CFM @ 85 PSI)	\$3,280.00
7F	MetalR+ Chemical Injection Package †	\$1,270.00

† Factory Install Only

CHEMICAL COAG TREATMENT KITS AND CONSUMABLES

Part No.	Description	List Price
Special	CoAg Bench Scale Test Kit	CALL
8.720-009.0	Chlorine Test Strips	\$58.00
8.753-577.0	pH Test Strips	\$72.50
8.725-445.0	CoAg+ Coagulant – 5 Gallons	\$398.00
8.725-446.0	CoAg+ Coagulant – 55 Gallons	\$3,799.00
8.940-586.0	EC+ Flocculant (Polymer) – 5 Gallons	\$149.00
8.725-508.0	EC+ Flocculant (Polymer) – 55 Gallons	\$1,075.00
8.750-280.0	Metal R+ Coagulant – 5 Gallons	\$524.00
8.750-281.0	Metal R+ Coagulant – 55 Gallons	\$4,525.00
8.749-550.0	Liquid Alum (Aluminum Sulfate) – 5 Gallons (pH control)	\$130.00
8.749-549.0	Liquid Alum (Aluminum Sulfate) – 55 Gallons (pH control)	\$779.00

pH Permissive Control System



The PH-3020D system incorporates: a digital (dual) pH controller that monitors and adjusts to both base and acid pH set points; a circulation pump; and chemical injection peristaltic pumps. Once the pH set points (high or low) are satisfied, the permissive interlock system of the controller will provide an output signal for the purpose of downstream release and/or post processing of the water.

(For additional details, refer to the pH Permissive product sheet)

Balances water pH

Automatic adjustment recommended

A balanced pH promotes: solids to settle out quicker; emulsified oils to become more buoyant; and some metals to precipitate

Stand alone systems

Factory installed options incorporated into a base product

TECHNICAL DATA

Model	Part No.	Description	Voltage	AMPS	List Price
PH-3020D	1.103-458.0	pH Permissive Control System	120	9	\$12,144.00

OPTIONAL ACCESSORIES

Part No.	Description	List Price
8.903-682.0	Auto Fill (SS sump pump, fittings and floats) ‡	\$2,785.00
8.903-681.0	Holding Tank, 300 gal. (valves and hose)	\$3,635.00

‡ Factory Install Only

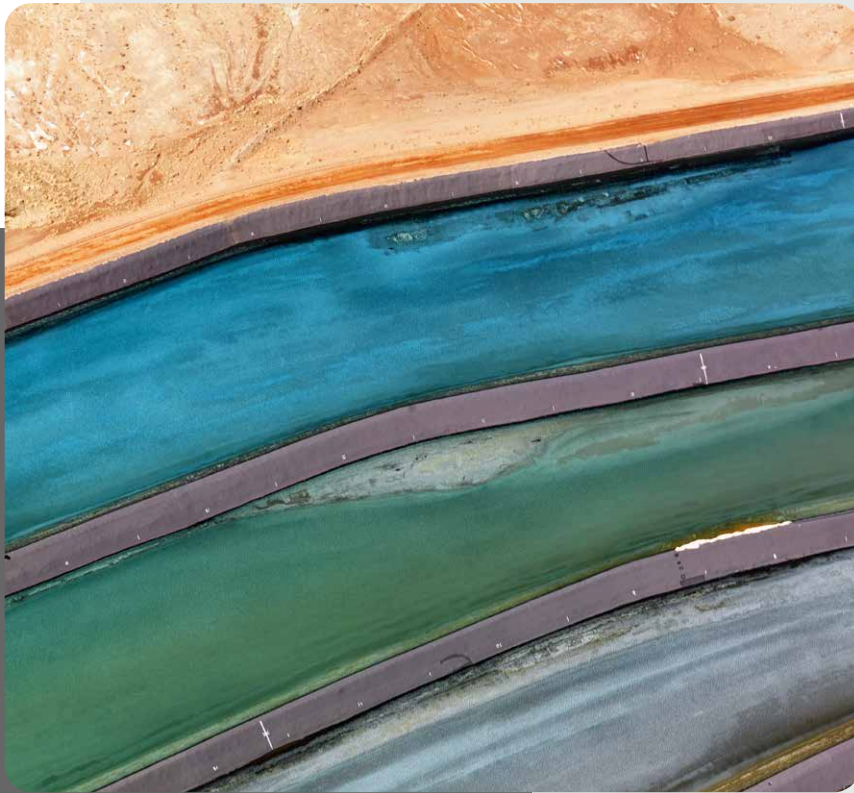

Filtration

REC-ZCF



The REC-ZCF3-30A is a major advance in filtration performance. Delivering superior recycled water quality with fully automatic operation, the plug-and-play unit is pre-piped and wired, ready for connection to tanks and wash process. Flexible programming and self-cleaning backwash cycles enables large volumes of waste water to recycle while generating a minimum amount of waste volume. Using robust, industry-standard components built into a highly functional structural steel frame with a stainless steel base. As a powerful and flexible pumping and filtration system that can serve as the hub of a wide range of treatment system processes.

The REC-ZCF2 is a variation with three separate transfer pumps, each with a dedicated job; in-feed, circulation, and transfer. 1) Transfer water through the ZCF particle filters to the treated water tank. 2) Ozonate and stir water in the treated water tank to control odor, and 3) Send water to the pressure washers. Plumbing fittings for inputs and outputs have been standardized and access to all parts of the machine improves ease of maintenance. This unit can be subbed for any product using the standard 1-pump REC through a Specials order.

The REC-ZCF1 is a slimmed down version of the popular filtration unit with only one filter housing. Perfect for systems needing intermittent use at less than 10 gpm.

- Plug and play filtering
- Standard stainless steel skid
- Two media filters with automatic back washing
- Two automatic control valves

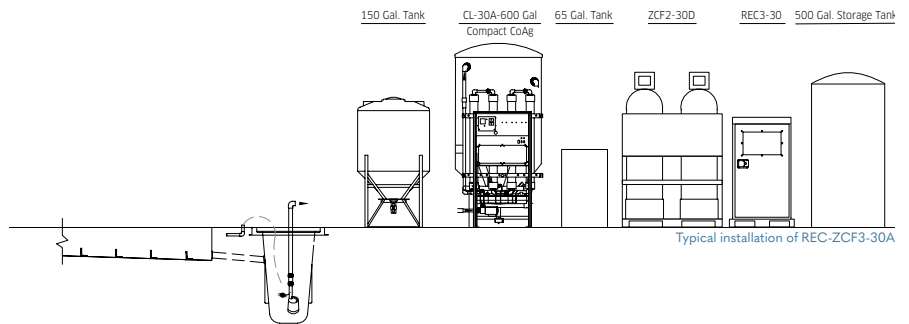

TECHNICAL DATA

Model	Part No.	Description	Filtration Rate GPM	Transfer Rate GPM	Voltage	Phase	AMPS	List Price
REC-ZCF3-30A	1.103-513.0	Pumping & Filtration System	up to 20	up to 30	230	1	20	\$39,732.00
REC-ZCF2	Special	Pumping & Filtration System with 3 pumps: <i>in-feed, circulation, and transfer pumps</i>	up to 20	up to 30	230	1	36	\$45,732.00
REC-ZCF1	Special	One media housing (1.103-513.0 single pump system only)	up to 10	—	230	1	20	\$36,345.00

REC Series

**NEW
3 PUMP
VARIATION**



A compact water management control center. Typically installed to transfer water from a clarifier to filtration or water storage. When combined with the ZCF filtration module, it pumps influent water through the filters to remove particulate, as well as provides pressurized water for backwashing and for recycling purposes. It provides makeup water, as well as discharges any excess water volume.

New to the series, the REC-ZCF2 is a variation with three separate transfer pumps, each with a dedicated job; in-feed, circulation, and transfer.

Designed to interface with pretreatment & post treatment modules

Stainless steel skid with painted carbon steel enclosure

Lockable front door

Easy access to components (pump, piping, & electrical)

TECHNICAL DATA

Model	Part No.	Description	Flow GPM	Voltage	Phase	AMPS	List Price
REC3-30A	1.103-511.0	Water Management Pumping System	up to 30	230	1	20	\$17,012.50
REC3-30A Special	Special	REC3-30A with 2 HP Self-priming pump (upgrade add-on to 1.103-511.0 single pump system only)	up to 40	230	1	20	\$1,500.00
REC2-20A	Special	Water Management Pumping System with 3 pumps: <i>in-feed, circulation, and transfer pumps</i>	up to 30	230	1	36	\$23,015.00

OPTIONAL ACCESSORIES

Part No.	Description	List Price
8.928-603.0	Ozone Generator Kit for REC3-30A	\$1,590.00

ZCF Filter Pac



Specifically designed to pair with the REC series module, the ZCF Filter Pac delivers a major advance in filtration performance, delivering superior recycled water quality with fully automatic operation. Flexible programming and self-cleaning backwash cycles enable the ZCF to recycle large volumes of waste water while generating a minimum amount of waste volume. The ZCF uses robust, industry-standard components built into a highly functional structural steel frame with stainless steel base.

Flexible programming and self-cleaning backwash cycles

Effective recycling system in a small footprint

Specifically designed to pair with the REC series module

Designed to fit through 36" man doors for maximum installation flexibility

TECHNICAL DATA

Model	Part No.	Description	Filtration Rate GPM	Voltage	Phase	AMPS	List Price
ZCF2-30D	1.103-512.0	ZCF Filter Pac	up to 20	120	1	5	\$18,012.50
ZCF1-D	SPECIAL	ZCF Filter Pac - One Filter Housing	up to 10	120	1	3	CALL

FILTER MEDIA

Part No.	Description	List Price
MULTI-MEDIA PROVIDES SOLIDS SEPARATION / VIRGIN COCONUT SHELL ACTIVATED CARBON		
8.757-147.0	Zeolite, 50 lb Bag*	\$95.50
8.718-920.0	Sand, 20-40 Size, 50 lb Bag	\$0.65 / lb
8.718-921.0	Gravel, 50 lb Bag*	\$0.75 / lb
8.718-922.0	Anthracite #1 .60-.80mm, 50 lb Bag	\$2.35 / lb
8.718-923.0	Garnet, 30 x 40, 100 lbs per Bag	\$1.70 / lb
8.718-924.0	Garnet, 8 x 12, 50 lbs per Bag*	\$2.55 / lb
8.718-933.0	Carbon, Virgin Coconut, 8 x 30 55 lb Bag	\$405.00

*Media Included in ZCF Filter Housing



Sand

High Boy



High Boy Stainless Steel

The IPF solids unit utilizes inexpensive fabric media to filter out solids. Filter fabric, which is supplied in 5, 20, and 50 micron sizes, is automatically indexed onto a recessed conveyor belt constructed of a high tensile, non-corrosive material. As water and solid particles drain through the filter fabric, solids are retained. As the water level rises, a float will actuate a drive motor and the conveyor belt will index the spent paper and new paper replace it. The IPF can be applied for pre-treatment, post treatment, or as a stand alone treatment system.

Carbon steel exterior with a stainless steel interior

Includes a collection container for spent paper and sludge

Exterior mounted drive motor with a covered housing

82-gallon tub included

TECHNICAL DATA

Model	Part No.	Description	Flow GPM	Height (Inches)	Container (Gal)	Voltage	Phase	AMPS	List Price
High Boy	1.103-488.0	High-Boy Indexing Polishing Filter	1-20	47.56	optional	120	1	3	\$9,763.00
High Boy	Special	High-Boy Indexing Polishing Filter with 82-gallon tub	1-20	47.56	82	120	1	3	\$12,080.00
High Boy - SS	Special	High-Boy Indexing Polishing Filter with all carbon steel components made of Stainless Steel	1-20	47.56	optional	120	1	3	\$15,215.00
High Boy - SS	Special	High-Boy Indexing Polishing Filter with all carbon steel components made of Stainless Steel with 82-gallon tub	1-20	47.56	82	120	1	3	\$17,530.00

OPTIONAL ACCESSORIES

Part No.	Description	List Price
8.752-171.0	Fabric Media, Filter – 50 Micron x 1100 Yards	\$831.00
8.752-173.0	Fabric Media, Filter – 20 Micron x 650 Yards	\$768.00
8.752-172.0	Fabric Media, Filter – 5 Micron x 500 Yards	\$891.00
8.929-152.0	Water Retention Container (approximately 82-gallon capacity)	\$1,110.00
8.917-279.0	Water Retention Container (approximately 40-gallon capacity)	\$524.00

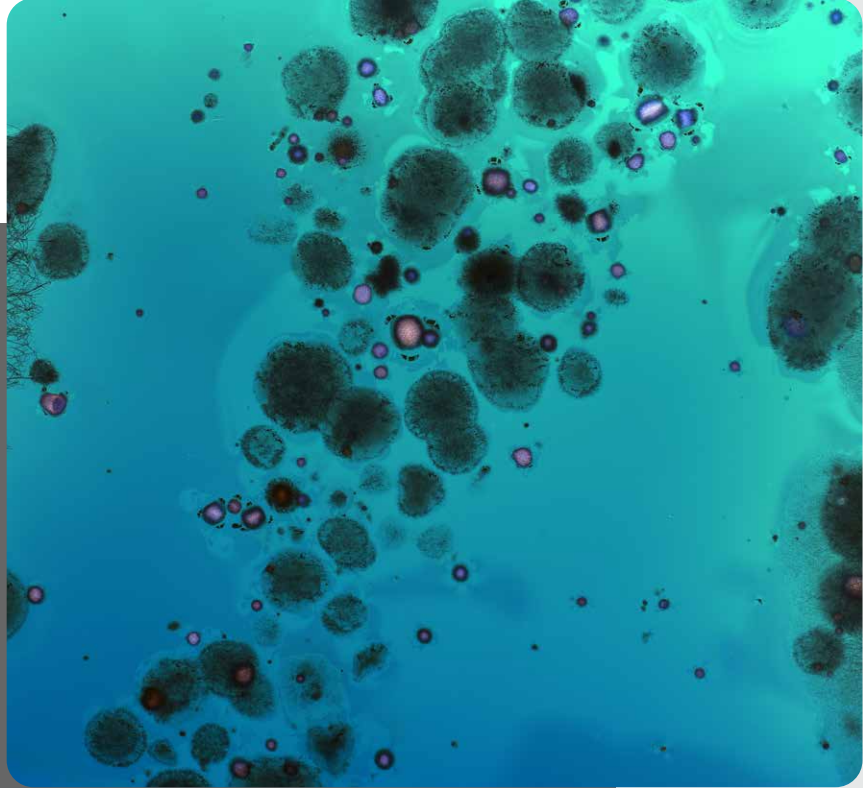

Bio-Digestion

Universal Clarifier: Bio-Digester Option



Bio-digestion is the best way to treat dissolved organic chemicals in your water. To convert the Universal Clarifier into an aggressive bioreactor, we load it with high surface area fill material that allows the microbes to establish high concentration and activity levels in the clarifier. We also connect a PM-1000D aeration and recirculating system to manage feeding the microbes the necessary amount of air and nutrients to allow them to thrive and chew up your contaminants as quickly as possible.

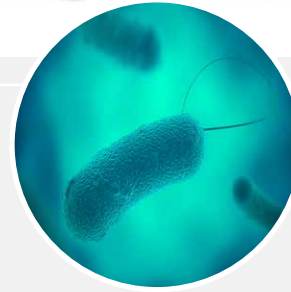

TECHNICAL DATA

Model	Part No.	Description	Stand	Capacity (Gal)	Flow GPM	List Price
CLT-600	1.103-435.0	Modular Clarifier System Base Unit	■	600	1 - 30	CALL

MODULAR CLARIFIER BIO-DIGESTER OPTION

Part No.	Description	List Price
7B-600	AMC-1000D Auto-purge System (4CFM @ 85 PSI), 120 V/2 Amps**	\$3,110.00
7C-600	UV Ozone System with circulation pump and timer, 120 V/9 Amps**	\$5,050.00
7D	pH (only) Controller with one peristaltic pump electrically interfaced with the infeed pump / sump pump circuit †	\$4,910.00
7G	Auto-water Discharge/Circulation Valve System, 120 V/2 Amps**	\$1,610.00
8.906-478.0	Sludge Tub with Lid	\$662.00
8.712-417.0	Diffuser Stone, fine pore, 2"x2"x6.5"	\$270.00
8.707-435.0	Biomedia Bag	\$116.00
8.706-676.0	EoFill (BioMedia) - 8 lbs / bag (sold by the pound)	\$18.80
CLT-600 ONLY		
7A-600	600-gallon Mounting Shield †	CALL

† Factory Install Only. * Requires Rain Guard and Bracket option. NOTE: Sump pumps sold separately. Consult CL Quick Start Guide for full system options. Extended lead times apply to all orders placed through our Specials Department.

PM-1000D

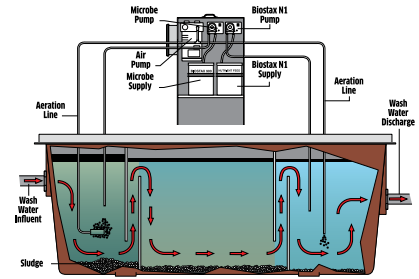

PM-1000D and Collection Pit

The PM-1000D provides a fully automated, environmentally friendly and low-cost way to manage standing wash water found in collection pits, tanks or sump drains. A module that incorporates: an air pump; diffuser stones, microbes and nutrients injection system with timer, it is designed to be integrated into most wash water treatment systems utilizing aeration and automatic injection of a highly effective microbial agent for eliminating oils, greases and other hydrocarbons and organics typically found in collection pits or sump drains.

Easy in-field installation

Effectively reduces odor

Fits most brands of water treatment systems

Biology consumes oils, grease, hydrocarbons, etc.

Steel cabinet protected by epoxy powder coat finish

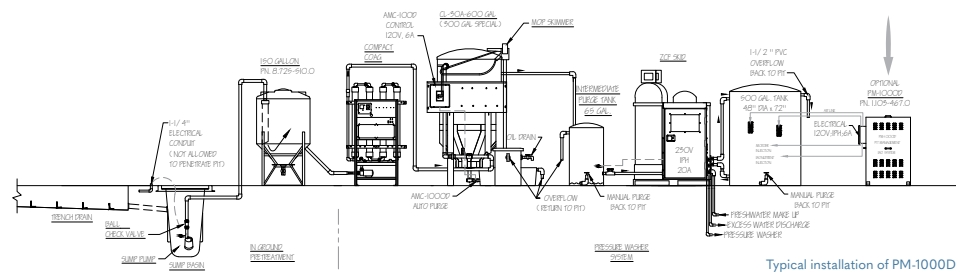

Typical installation of PM-1000D

TECHNICAL DATA

Model	Part No.	Description	Voltage	Phase	AMPS	List Price
PM-1000D	1.103-467.0	Automatic Pit Management System	120	1	4	\$6,325.00
PM-1000D	Special	Pit Management System with Regenerative Blower and 10 Jetter Diffusers	120	1	6	\$8,985.00

OPTIONAL ACCESSORIES

Part No.	Description	List Price
8.718-918.0	BioStax 1800, liquid, 2 containers A&B (concentrate makes 55 gallons)**	\$1,145.00
8.718-917.0	BioStax 100 Hawaiian Blend, liquid, 8 oz. vial	\$147.00
8.718-919.0	BioStax 1800, Two 8 oz vials (A & B) makes 5 gallons	\$162.00
8.718-916.0	Bio-Nutrient, 8 oz bottle	\$71.00
8.712-417.0	Diffuser Stone, fine pore, 2" x 2" x 6.5"	\$270.00
8.707-435.0	Biomedica Bag	\$116.00
8.706-676.0	EoFill (BioMedia) – 8 lbs / bag (sold by the pound)	\$18.80

** Non-stock item



Evaporation

HBG



HBG-30D Stainless Steel

The gas-heated HBG system is capable of evaporating wastewater at up to 30 gallons per hour. The combustion box in the HBG is made of advanced heat reflective material and features a unique energy-efficient design for reflecting the heat directly onto the floor of the evaporation tank for energy cost savings. A high-efficiency burner shoots a flame, fueled by natural gas or propane, into the combustion chamber for unusually high energy efficiency. The unit is made of heavy-duty steel, insulated and double lined for both energy efficiency and safety.

Evaporates waste water up to 30 gallons per hour

Gas-heated system

Combustion box made of advanced heat reflective material

High energy efficiency

TECHNICAL DATA

Model	Part No.	Description	BTU	Evaporation Technology	Flow Rate GPH	Exhaust Stack (Inches)	Capacity (Gal)	Voltage	Phase	AMPS	List Price
HBG-30D	1.103-449.0	Wastewater Evaporator	311,000	Hot-Plate	up to 24	10	100	120	1	3	\$31,993.00

OPTIONAL ACCESSORIES

Part No.	Description	List Price
8.903-740.0	Air Diaphragm Fill Pump & Level Controls for Auto Fill (compressed air required, 3 cfm at 60-100 PSI) †	\$4,700.00
8.903-753.0	Electric Centrifugal Fill Pump & Level Controls for Auto Fill †	\$4,590.00
8.903-741.0	Motorized Belt Oil Skimmer, 316L Stainless Steel †	\$2,620.00
8.906-074.0	Chemical Injector, Defoamer, Air-Injected †	\$2,300.00
8.906-073.0	Inline Chemical Injector for Anti-foam or Rust Inhibitor, Electric-Powered †	\$1,390.00
8.903-749.0	Tank Conversion to 316L Stainless Steel †	\$8,500.00
8.903-750.0	Tank Conversion to AL-6XN †	\$33,050.00
8.906-077.0	Conversion from Natural Gas to Propane †	\$410.00
8.717-742.0	10" Flue Pipe Rain Shield	\$547.00
SPECIAL	Convert All Carbon Steel Parts to Stainless Steel †	CALL

WATER ANALYSIS AND KITS FOR EVAPORATION SYSTEMS

Part No.	Description	List Price
8.750-241.0	Metal Analysis (includes Ag, As, Ba, Cd, Cr, Pb, Se Hg, Cu, Zn, Ni)	\$280.00†
8.750-242.0	Base Analysis for Evaporators (includes analysis of pH dissolved and suspended solids, Total Oils & Greases, NP [Non-Polar] Oils & Greases, Anions [Cl, NO3, o-PO4, SO4], Flashpoint, Viscosity, Cations [B, Ca, Fe, K, Mg, Na])	\$550.00†
8.750-243.0	VOC Analysis (includes 67 VOC compounds by EPA 8260) for Evaporation Systems	\$275.00†
8.719-146.0	Evaporator Waste Stream Sampling Kit	\$98.50

† Factory Install Only. † Net price – no dealer discounts; to expedite processing time of wastewater analysis, multiply net price by a factor of 1.5

WB



The WB series is the first to use the extra-high efficient submerged combustion technology to deliver 100% heat exchanger efficiency sending the heat directly into the water, not up a vent stack, creating significant operational and energy cost savings. There are two models for handling waste streams at 60 and 120 gallons per hour. Featuring top-of-the-line immersion tube jet burner components, with a solid-state flame control monitor, the WB models are capable of creating temperatures of up to 2000°F, releasing hot flue gases directly into the water.

Waste streams up to 120 gallons per hour

Temperatures up to 2000°F

Top-of-the-line immersion tube jet burner components

Auto purge, auto start/stop and auto fill come standard

Heat-resistant, heavy-duty stainless steel sparger tube

TECHNICAL DATA

Model	Part No.	Description	BTU	Evaporation Technology	Flow Rate GPH	Exhaust Stack (Inches)	Capacity (Gal)	Voltage	Phase	AMPS	List Price
WB-120A	1.103-473.0	Wastewater Evaporator	1,142,000	Combustion	1 - 120	12	170	230	1	22	\$149,020.30
WB-50A	1.103-474.0	Wastewater Evaporator	571,000	Combustion	1 - 60	10	76	230	1	11	\$88,156.90

OPTIONAL ACCESSORIES

Part No.	Description	List Price
8.906-066.0	Conversion from Natural Gas to Propane † (Requires Qty 2 for WB-120A)	\$98.50
8.903-762.0	Foam Detection System †	\$3,610.00
WB-120A ONLY		
8.903-729.0	Tank and Tube Conversion to AL-6XN †	\$31,260.00
8.903-767.0	Wastewater Flame Injection System †	\$481.00
8.717-743.0	12" Flue Pipe Rain Shield	\$682.00
WB-50A ONLY		
8.903-725.0	Tank and Tube Conversion to AL-6XN †	\$25,600.00
8.903-766.0	Wastewater Flame Injection System †	\$395.00
8.717-742.0	10" Flue Pipe Rain Shield	\$547.00

WATER ANALYSIS AND KITS FOR EVAPORATION SYSTEMS

Part No.	Description	List Price
8.750-241.0	Metal Analysis (includes Ag, As, Ba, Cd, Cr, Pb, Se Hg, Cu, Zn, Ni)	\$280.00†
8.750-242.0	Base Analysis for Evaporators (includes analysis of pH dissolved and suspended solids, Total Oils & Greases, NP [Non-Polar] Oils & Greases, Anions [Cl, NO3, o-PO4, SO4], Flashpoint, Viscosity, Cations [B, Ca, Fe, K, Mg, Na])	\$550.00†
8.750-243.0	VOC Analysis (includes 67 VOC compounds by EPA 8260) for Evaporation Systems	\$275.00†
8.719-146.0	Evaporator Waste Stream Sampling Kit	\$98.50

‡ Factory Install Only. † Net price - no dealer discounts; to expedite processing time of wastewater analysis, multiply net price by a factor of 1.5

Evaporator Belt



Evaporation is achieved by electric-power with indirect heat through standard steel storage containers, making the evaporator belt an easily implemented and adaptable option when low-volume evaporation is needed. An economical alternative, the Evaporator Belt is ideal for evaporating very low volumes of wastewater. The electric-powered belt wraps around a standard 55-gallon steel drum and slowly heats non-flammable liquids to temperatures of 70° to 250°F. The heavy-duty aluminized steel belt includes thermostatic control and weighs only 14 pounds.

Low volume wastewater evaporation

Heats liquids to temperatures of 70° to 250°F

Aluminized steel belt

TECHNICAL DATA

Model	Part No.	Description	Evaporation Technology	Flow Rate GPH	Capacity (Gal)	Voltage	Phase	AMPS	List Price
Evaporator Belt	8.707-034.0	Wrap-It-Heat Water Reduction Belt	Electric	1.4	55**	230	1	12.5	\$2,020.00

WATER ANALYSIS AND KITS FOR EVAPORATION SYSTEMS

Part No.	Description	List Price
8.750-241.0	Metal Analysis (includes Ag, As, Ba, Cd, Cr, Pb, Se Hg, Cu, Zn, Ni)	\$280.00
8.750-242.0	Base Analysis for Evaporators (includes analysis of pH dissolved and suspended solids, Total Oils & Greases, NP [Non-Polar] Oils & Greases, Anions [Cl, NO3, o-PO4, SO4], Flashpoint, Viscosity, Cations [B, Ca, Fe, K, Mg, Na])	\$550.00
8.750-243.0	VOC Analysis (includes 67 VOC compounds by EPA 8260) for Evaporation Systems	\$275.00
8.719-146.0	Evaporator Waste Stream Sampling Kit	\$98.50

** Drum not included † Net price – no dealer discounts; to expedite processing time of wastewater analysis, multiply net price by a factor of 1.5



Additional Capacity

Above-ground Cone-bottom Tanks



Water Maze CLT-600 and CLT-300 models can be applied as pre-treatment, post treatment, or as a stand alone treatment system. These models utilize cross-linked polyethylene cone-bottom tanks with steep slopes (up to 55 degrees) for maximum solids separation. Each tank has a full open top with removable lid and includes heavy duty metal stand with cradle. These base models are also incorporated into other clarifier models within this products catalog with features and benefits to match your application requirements.

Expand system capacity

Provides cushion in handling high volumes of wash water

UV- and corrosion-resistant

TECHNICAL DATA

Model	Part No.	Description	Stand	Material	Capacity (gal)	List Price
CLT-600	1.103-435.0	Polishing Tank	■	—	600	CALL
CLT-300	1.103-434.0	Polishing Tank	■	—	300	CALL
Storage Tank	8.719-172.0	Intermediate Flat Bottom Tank	—	Polyethylene	165	\$1,295.00
Storage Tank	8.719-170.0	Flat Bottom Tank	—	Polyethylene	65	\$671.00
Storage Tank	8.719-173.0	Cone Bottom Tank	■	Polyethylene	310	\$3,095.00
Storage Tank	8.725-510.0	Cone Bottom Tank	Optional	—	150	\$838.00
Tank Stand	8.751-972.0	Tank Stand, 36" (45 degree) (Fits Cone Bottom Tank #8.725-510.0 Only)				\$690.00
Tank Stand	Special	Stainless Steel Tank Stand (Fits CLT-300 and CLT-600 Tanks)				CALL

NOTE: CLT-300 and CLT-600 Tanks are propriety to Water Maze and can be customized through our Specials Department to satisfy specific application requirements. See Page 25 for Universal Clarifier Systems and configuration options. Consult CL Quick Start Guide for full system options .



Solids Handling

Pit Cleaner

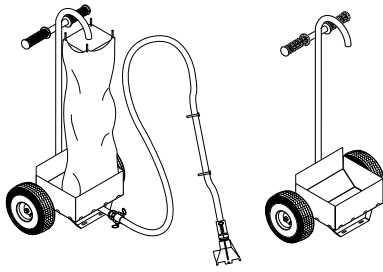

Shallow Pit Cleaner

Sludge Cart

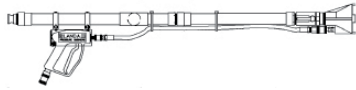

Pit Cleaner Assembly

- Easy sludge removal
- Capable of suctioning mud and sludge from the bottom of a pit or pond

TECHNICAL DATA

Model	Part No.	Description	Suction Flow GPM	Discharge Hose	Pressure Washer Req*		List Price
					PSI	GPM	
Pit Cleaner	8.903-601.0	Shallow Pit Cleaner, up to 2 Feet Deep (includes 1 bag)	15 - 40	8' x 1.25"	1000-3000	2.0-5.2	\$1,530.00
Pit Cleaner	8.903-600.0	Pit Cleaner Assembly	15-40	8' x 1.25"	1000-3000	2.0-5.2	\$1,090.00

OPTIONAL ACCESSORIES

Part No.	Description	List Price
8.709-206.0	Sludge Cart Only (includes 1 bag)	\$910.00
8.719-191.0	Sludge Bag, Biodegradable, cotton fiber (includes 1 bag)	\$7.75

*Pressure washer not included.

Hydro Screen



- Grass screen
- Small particle separator



TECHNICAL DATA

Model	Part No.	Description	List Price
Hydro Screen	8.903-783.0	Grass screen - Small particle separator	CALL

OPTIONAL ACCESSORIES

Part No.	Description	List Price
8.903-784.0	Mounting Bracket - Hydro Screen	CALL

Sludge Container



- Stainless steel perforated bottom for drainage
- Wheels and custom shape for easy transport and disposal of contents

TECHNICAL DATA

Part No.	Description	List Price
8.906-478.0	Sludge Tub with Lid	\$662.00
8.903-602.0	Sludge Container, 350 lb weight capacity	\$4,700.00



Demucking

Water Blaster



25 GPM and 500 PSI

2 Electrical Configurations

Rugged self-priming, high-pressure diaphragm pump

TECHNICAL DATA

Model	Part No.	Description	GPM	PSI	HP	Voltage	Phase	AMPS	List Price
Water Blaster	1.103-484.0	High Pressure Cleaning	25	500	10	230	3	30	\$15,569.45
Water Blaster	1.103-472.0	High Pressure Cleaning	25	500	10	460	3	15	\$15,293.20

OPTIONAL ACCESSORIES

Part No.	Description	List Price
8.711-863.0	Hose Reel, Cox 1/2"-100' 1175-6-100-CVXX	\$1,305.00

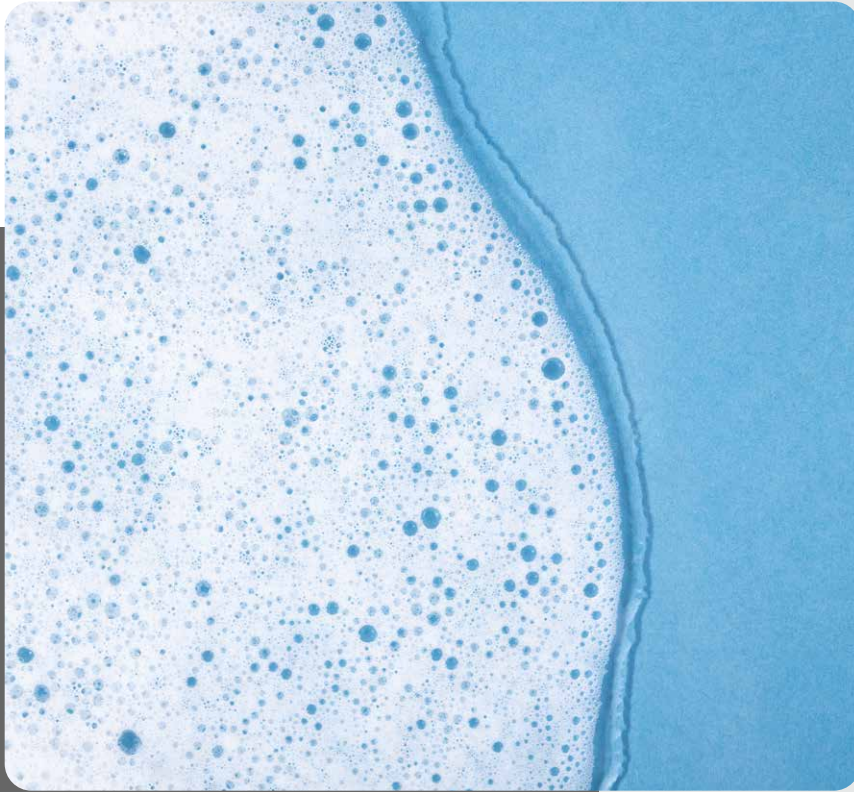

Consumables

CoAg+ Coagulant

CoAg+ Coagulant		List Price	ADDITIVES CHEMICAL COAGULANT FOR SUSPENDED SOLIDS, EMULSIFIED OILS, AND GREASES
8.725-445.0	5 gal	\$398.00	A proprietary and uniquely formulated coagulant, containing highly reactive polyaluminum chloride and polyamine. The CoAg+ is highly effective at coagulating suspended solids and emulsified oils and greases from a variety of applications. It is cost and performance effective when compared to other metal salts and polymer based treatment programs.
8.725-446.0	55 gal	\$3,799.00	

EC+ Plus Flocculant

EC+ Plus Flocculant		List Price	ADDITIVES CHEMICAL FLOCCULANT FOR SUSPENDED SOLIDS, EMULSIFIED OILS, AND GREASES
8.940-586.0	5 gal	\$149.00	An anionic flocculant for use with the Water Maze Innovator Series water treatment systems. It is extremely effective in wash water clarification and solids removal. When added continuously, after the water has been treated by electro-coagulation or the Water Maze CoAg+, EC+ PLUS promotes agglomeration of the coagulated suspended solids into larger particles, which are then easily removed from the water by settling and filtration.
8.725-508.0	55 gal	\$1,075.00	

Metal R+ Coagulant

Metal R+ Coagulant		List Price	ADDITIVES CHEMICAL COAGULATION – REDUCE METAL CONCENTRATION
8.750-280.0	5 gal	\$524.00	Provides an easy, flexible and cost efficient solution to reduce metal concentration. It is effective against a wide array of metals and removes various co-existing heavy-metals at the same time. The chelating power of the dithiocarbamate group allows the direct precipitation of complex or chelated metals. Chemically stable sludge is generated avoiding any secondary pollutions. It is extremely cost effective and will remove Cu, Zn, Hg, Pb, Cd, Ag, Ni, Co, Fe+2, Cr+3, Au, Pt and Sn.
8.750-281.0	55 gal	\$4,525.00	

pH Liquid

pH Plus Liquid		List Price	pH ADJUSTERS ALL WATER TREATMENT SYSTEMS – PH ADJUST CHEMICAL, ALL WATER TREATMENT SYSTEMS
8.698-046.0	5 gal	\$143.00	Use as a pH adjust chemical in water treatment applications to raise the pH. It is ideally suited for use with Water Maze water treatment systems, but is also suitable for use in a wide variety of waste water treatment applications where the pH needs to be raised. Best results are obtained when Water Maze pH Plus Liquid is injected directly into the waste water stream on an automatic basis.
Liquid Alum pH		List Price	ADDITIVES LIQUID ALUMINUM SULFATE SOLUTION – WATER TREATMENT SYSTEMS
8.749-550.0	5 gal	\$130.00	A 25% liquid aluminum sulfate solution for use as a pH adjust chemical or a coagulant in water treatment. It is ideally suited for use with Water Maze wash water treatment systems but is also suitable for use in a wide variety of waste water treatment systems and applications. Best results are obtained when Water Maze Liquid Alum is injected directly into the waste water stream on a continuous basis.
8.749-549.0	55 gal	\$779.00	
Liquid Citric pH		List Price	ACID Liquid Citric pH 50%
8.760-235.0	5 gal	CALL	Water Maze Liquid Citric pH is a 50% citric acid solution for use as a pH adjustment in water treatment. Use in water treatment applications to lower the pH. It is ideally suited for use with Water Maze water treatment systems but is also suitable for use in a variety of wastewater treatment systems and applications.
8.760-236.0	55 gal	CALL	
Liquid Sulfuric pH		List Price	ACID Liquid Sulfuric pH 35%
8.760-237.0	5 gal	CALL	Water Maze Liquid Sulfuric pH is a 35% sulfuric acid solution for use as a pH adjustment in water treatment. Use in water treatment applications to lower the pH. It is ideally suited for use with Water Maze water treatment systems but is also suitable for use in a variety of wastewater treatment systems and applications.

No Rust

No Rust		List Price	ADDITIVES CONCENTRATED CORROSION INHIBITOR – CARBON STEEL TANK EVAPORATORS
8.749-782.0	5 gal	\$818.00	A concentrated corrosion inhibitor that is designed to provide rust protection in Water Maze industrial waste water evaporators. When added continuously this unique blend of chemicals will prevent corrosion to the wetted metal surfaces of a waste water evaporator. Water Maze No Rust also acts as a dispersing agent, which helps prevent deposit build-up in the evaporator tub and facilitates removal of the concentrate at the end of the evaporation cycle. This helps maintain energy efficiency during the evaporation process and adds to the ease of evaporator cleaning and concentrate removal.

OxiMaze+

OxiMaze+*		List Price	ADDITIVES OXIDIZER – ALL WATER TREATMENT SYSTEMS
8.750-499.0	5 gal	\$300.00	A powerful oxidizer to be used as a sanitizer for very effective odor control within waste water treatment systems. OxiMaze+ is a much safer and more effective alternative to chlorine (sodium hypochlorite). Non-toxic, non-corrosive and has a much higher reactivity rate than chlorine, OxiMaze+ also stays in the wastestream much longer than other sanitizers (like ozone gas), making it a very effective treatment, long term. OxiMaze+ kills pathogens in wastestreams, and the required ORP (Oxidation Reduction Potential) level is much less than Chlorine (almost 50% less). Shipped in concentrate form, OxiMaze+ saves shipping costs allowing you to offer a better solution to your customer.
8.750-500.0	55 gal	\$3,005.00	

Quick Release Detergents

Enviro-Clean+Plus*		List Price	DETERGENT WASH WATER APPLICATIONS – QUICK RELEASE, LOW PHOSPHATE, ALL PURPOSE
8.916-589.0	5 gal	\$78.50	Combines both the cleaning power of other detergents with oil-release properties to enhance the effectiveness of a wash water recycling system or oil-water separator. It has low-foaming and low-phosphate characteristics and contains no caustics or butyls. Safely on many surfaces, including aluminum, stainless steel, glass, plastic, paint and even fine automotive paint finishes. It is ideal for cars, trucks, machinery, exterior walls, heavy equipment, farm implements, RVs, drilling rigs, mining equipment, buses, and other items that may require use of a recycling system or oil-water separator.
Enviro-Degreaser*		List Price	DETERGENT WASH WATER APPLICATIONS – QUICK RELEASE, PHOSPHATE FREE, DEGREASER
8.916-590.0	5 gal	\$92.50	A potent degreaser that also has quick-release properties so it is ideal for use when water is being treated by a wash water recycle system or oil-water separator. It is phosphate free and does not react photochemically so it's enviro-safe. Water Maze Enviro-Degreaser can be used safely on many surfaces, including aluminum, stainless steel, glass, plastic, paint and even fine automotive paint finishes. It is ideal for use on vehicles, engines and other objects exposed to high amounts of grease and grime. It is especially effective as a pre-spray for cleaning engines, white-wall tires, vinyl tops and metal tops.
8.916-593.0	55 gal	\$799.00	

Defoam / Antifoam

5600 Defoamer*		List Price	DEFOAMER EVAPORATION APPLICATIONS – EVAPORATION, DEFOAMER CONCENTRATE
8.719-138.0	1 gal	\$81.00	A fast-acting defoamer concentrate that quickly suppresses froth and suds often found in waste streams bound for processing through a waste water evaporation system. Water Maze 5600 can also be used in aqueous-based waste water treatment systems.
8.719-139.0	5 gal	\$350.00	
8.719-140.0	55 gal	\$3,350.00	

*Cannot Ship Via UPS

Bio-nutrients

- Exclusive to Waterstax
- Biodegradable
- Store in cool location or refrigerator
- Convenient packaging



Biostax 1800



Bio-Puck

Part No.	Description	List Price
8.718-913.0	Bio-Puck HC, 4-pack with BioNutrient and 4 pit socks	\$274.00
8.749-853.0	Bio-Puck HC, box of 20 pucks	\$952.00
8.718-914.0	Bio-Puck GT, 4-pack with 4 pit socks	\$147.00
8.718-918.0	Biostax 1800, makes 55 gallons	\$1,145.00
8.718-917.0	Biostax 100 Hawaiian Blend (8 oz Vial), makes 5 gallons	\$147.00
8.718-916.0	Bio-Nutrient, 8 oz bottle	\$71.00
8.718-919.0	Biostax 1800 (Two 8 oz Vials)	\$162.00
8.712-417.0	Diffuser Stone, fine pore, 2"x2"x6.5"	\$270.00
8.707-435.0	Biomedica Bag	\$116.00
8.706-676.0	EoFill (BioMedia) – 8 lbs / bag (sold by the pound)	\$18.80

Clay & Filter Paper

- Virgin coconut shell activated carbon
- Multi-media provides solids separation



Clay

Part No.	Description	List Price
8.718-927.0	Clay, BC-77 DKG (50 lb Bag)- Ideal for treating oils, metals, detergents	\$269.00
8.718-928.0	Clay, BC-77 KAG (50 lb Bag)- Ideal for treating oils, metals, detergents and to lower the pH	\$276.00
8.718-930.0	Clay, BC-77 JSG (50 lb Bag)- Ideal for treating recycle water	\$276.00
8.718-931.0	Organoclay, OC-77 (50 lb Box)- Organophile blend with anthracite to remove emulsified oils and organics	\$463.00
6.295-164.0	IPF Kärcher Clay RM-847 (44 lbs)- Ideal for treating heavily mineral oil contaminated water	\$193.00
8.752-171.0	IPF Fabric Media, Filter- 50 Micron x 1100 Yards	\$831.00
8.752-173.0	IPF Fabric Media, Filter- 50 Micron x 650 Yards	\$768.00
8.752-172.0	IPF Fabric Media, Filter- 50 Micron x 500 Yards	\$891.00

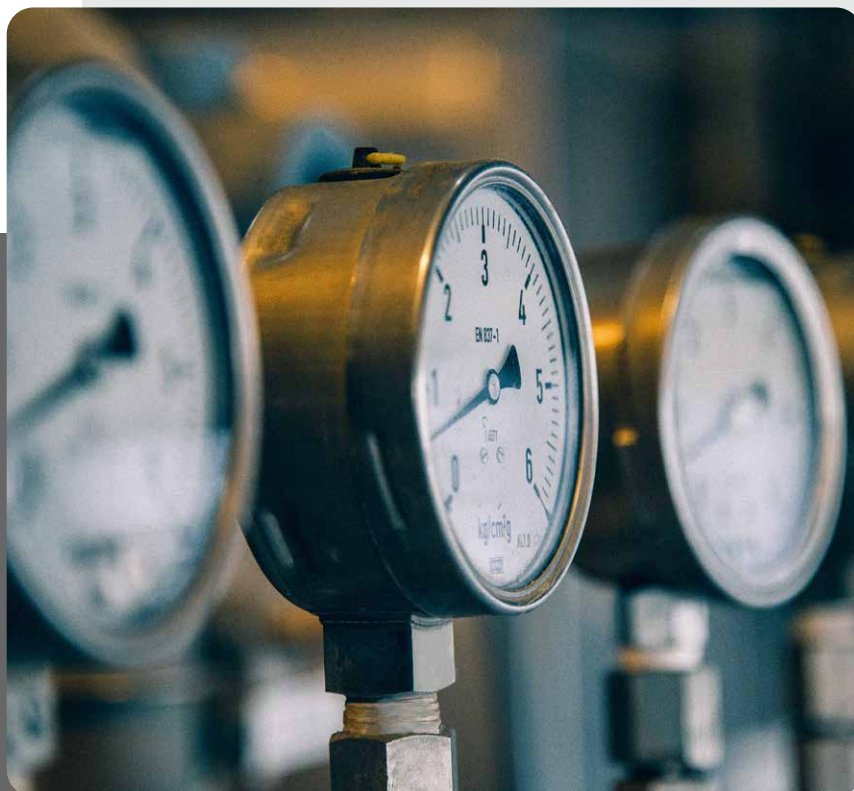

Accessories & Parts

Accessories enhance the effectiveness of Industrial Wastewater Treatment Systems

Water Maze offers a broad selection of add-ons, accessories, parts, and consumables that support the performance of your water treatment systems.

Filter Tanks and Elements

- Roto-molded for strength
- Corrosion and UV Resistant
- Self cleaning laterals
- Patented water distribution system



Media Filter



Filter Tank with Element

Part No.	Description	List Price
8.726-028.0	Media, 3.1 sq ft, CrystalFlo II	\$1,345.00
8.726-029.0	Media, 4.9 sq ft, Tagelus 100D	\$2,465.00
8.723-204.0	Filter Tank, 125 sq ft, with element, StaRite	\$1,700.00
8.723-205.0	Filter Tank, 200 sq ft, with element, StaRite	\$1,725.00
8.723-206.0	Filter Tank, 300 sq ft, with element, StaRite	\$3,100.00
8.723-215.0	Cartridge Element, 125 sq ft, StaRite	\$483.00
8.723-216.0	Cartridge Element, 200 sq ft, StaRite	\$770.00
8.723-217.0	Cartridge Element, 300 sq ft, StaRite	\$1,010.00
8.716-840.0	Element, 200 sq ft, 20 Micron, Jacuzzi*	\$444.00
8.716-847.0	Element, 250 sq ft, 20 Micron, Jacuzzi*	\$600.00
8.716-871.0	Element, 200 sq ft, 5 Micron, Jacuzzi*	CALL
8.716-872.0	Element, Filter, 100 sq ft, Jacuzzi*	\$413.00

*Limited supply; contact Customer Service for availability

Air Valves

- Simple design
- Maintenance free - Self cleaning



3 Way Ball Assembly

Part No.	Description	List Price
8.749-845.0	3 Way Ball Assembly, CLP Automatic	\$1,790.00
8.716-426.0	Solenoid, Air, 24V, Gemu Type 322	\$413.00
8.756-648.0	Valve, Ball, 1.5" Pneu Act, No Solenoid	\$1,070.00
8.756-462.0	Solenoid, Valve, 24VAC, SV61	\$361.00
8.756-652.0	Solenoid, Valve, Air, 120V, SV61	\$486.00
1.103-406.0	AMC-1000D, Auto-Purge (in-field kit)	\$3,160.00

WB Blower & Draft Inducer

- External motor
- Aluminum fan



Draft Inducer

Part No.	Description	List Price
8.715-192.0	Draft Inducer D-3, HBG/HBE	\$807.00
8.715-190.0	Blower, Regenerative, 2.5HP, R-6125	\$7,105.00

Alpha Coalescing Parts

- Oil-Loving polypropylene grids
- Proprietary maze design for optimum oil-water separation



Coalescing Grid

Part No.	Description	List Price
8.706-666.0	Grid, Vertical Coalescing, Large, 20.5" x 32.5"	\$67.50
8.706-668.0	Grid, Mini Coalescing, Small, 17" x 16"	\$28.40
8.706-671.0	Grid, Horizontal Coalescing	\$62.00
8.706-672.0	Suitcase Only For Pom Pom Filters (filters not incl.)	\$348.00
8.706-673.0	Pom Pom, Sorbaid (order 2 per suitcase)	\$11.70
8.706-675.0	Grid, Horizontal Coalescing (Delta 500)	\$25.20
8.709-338.0	Strap, Coalescing Grid, 60"	\$7.90
8.709-339.0	Strap, Coalescing Grid, 112"	\$10.00
8.709-342.0	Strap, 84", Filter	\$12.10

HBG Burners

- Industrial duty
- Simple operation



HBG-400

Part No.	Description	List Price
8.717-099.0	Wayne, P250 AFEP, 115V, HBG-15 NG	\$1,850.00
8.717-100.0	Wayne, HSG-400, HBG-30	\$2,990.00
8.717-101.0	Wayne, P250 AFEP, 115V, HBG-15 LPG	\$1,835.00

HBG Burner Parts

- Industrial applications

Part No.	Description	List Price
8.717-990.0	Ignition Module, HBG-15	\$240.00
8.717-991.0	Valve, Gas Burner HBG-15	\$514.00
8.717-992.0	Valve, Gas White Rodgers HBG-30	\$560.00
8.718-006.0	Control, Primary Safety, w/ 30 Sec Pre-Purge HBG-30	\$219.00
9.115-183.0	Control, Ignition, Wayne Series 8 HBG-30	\$218.00
8.718-000.0	Relay - Motor, 62406-002, HBG-30	\$71.00

Exhaust Stacking

- Rain protection
- Back pressure reduction



Rain Shield

Part No.	Description	List Price
8.717-738.0	Flue Adapter, 6" HBG-15, No Flange	\$209.00
8.717-739.0	Flue Adapter, 10" HBG-30, No Flange	\$209.00
8.717-740.0	Shield, Rain, 6" Flue Pipe, Water Blaze	\$283.00
8.717-742.0	Shield, Rain, 10" Flue Pipe, HBG	\$547.00
8.717-743.0	Shield, Rain, 12" Flue Pipe, WB-120	\$682.00

Flow Meters & Gauges

- Simple design
- High impact plastic



Flow Meter

Part No.	Description	List Price
8.712-136.0	Flow Meter 1.5"	\$315.00
8.712-154.0	Pressure, 0-100 1/4" Bottom	\$20.90
8.712-155.0	Pressure, 0-10 PSI	\$61.00

ORP/pH Controller Parts

- ORP/pH probes resistant to fouling
- Original replacement parts



ORP/pH Digital CH250 Controller

Part No.	Description	List Price
8.711-736.0	Tubing, 1/4" ID x 7/16" OD, Norprene	\$8.00
8.716-970.0	Fitting, Compression 1/2"	\$39.00
8.716-979.0	Kit, VSP-20 Parts, Suction/ Discharge Kit	\$435.00
8.716-984.0	Tubing, ORP/pH Controllers 15 ft Opaque	\$81.00
8.716-986.0	Injector, I.P.F. ORP/VSP 20 Metering	\$96.50
8.716-990.0	Controller Only, ORP/pH Digital CH250	\$5,330.00
8.716-989.0	pH-only Controller w/ probe, 120V, stand alone	\$3,850.00
8.753-578.0	Sensor, pH	\$508.00
8.753-579.0	Sensor, ORP	\$729.00
8.716-999.0	Controller, pH, LMI, DP-5000-1A-O	\$4,140.00
8.717-000.0	Probe, Sensor, EX, pH	\$807.00
8.717-001.0	Probe, Cable, 10'	\$284.00

Ozone Generators

- High output ozone for effective oxidation of bacteria and control of odor
- Ultra-violet ozone generation
- 1-, 2-, 4-bulb configurations



Ozone Generator

Part No.	Description	List Price
8.905-714.0	Series 200 (120V)	\$1,565.00
8.905-715.0	Series 200 (220V)	\$1,500.00
8.928-603.0	Ozone Generator Kit (Control Center, Ozone Lamp, and Housing)	\$1,590.00

Above models require power supply and/or circulation system

Ozone Generator Parts

- Direct replacement UV lamps



Lamp, Ozone Replacement

Part No.	Description	List Price
8.757-296.0	Lamp, UV Ozone, GUV-16-AIR	\$155.00
8.757-295.0	Control Center	\$534.00
8.707-321.0	Valve, Ozone Meter, 1/4" Plastic	\$64.00
8.707-355.0	Valve, 3/8" Tubing Check, Kynar	\$31.00
8.709-431.0	Injector, Ozone w/o Check Valve	\$245.00
8.716-590.0	Ballast, 120V / 220V Ozone Generator with 4 Pin Plug	\$121.00
8.716-600.0	Lamp, Ozone Replacement	\$180.00

Scot Pumps & Repair Kits

- Heavy-duty cast iron body
- Stainless steel impeller



Scot Pump

Part No.	Description	List Price
8.715-400.0	1-½ hp 208/230/460V 3PH, 20 GPM/ 50 PSI	\$1,935.00
8.715-402.0	2 hp 208/230V 1PH, 50 PSI	\$1,770.00
8.715-404.0	2 hp 208/230/460V 3PH, 32 GPM/ 50 PSI	\$1,625.00
8.715-357.0	2 hp 115/230V 1PH, Stainless Steel	\$2,160.00

Little Giant Pumps

- Heavy-duty cast iron



Little Giant Pump

Part No.	Description	List Price
8.715-367.0	Sump, ½ hp 120V	\$1,690.00
8.715-369.0	Sump, ⅓ hp 220V	\$783.00
8.753-541.0	Pump, Submersive 10S-CIM 208-240V (Requires Part #8.753-542.0)	\$1,775.00
8.753-542.0	Mech Float Switch 15' Cord (Requires Part #8.753-541.0)	\$193.00

Ebara Pumps

- Heavy-duty impeller
- Stainless steel



Ebara Pump

Part No.	Description	List Price
8.715-438.0	Sump, ½ hp 230V / 3PH	\$2,430.00
8.715-439.0	Sump, ½ hp 460V / 3PH	\$2,415.00

Peristaltic Metering Pumps

- Roller cam designed
- Hose compression pump



Peristaltic Pump



VSP20 Metering

Part No.	Description	List Price
8.919-139.0	Pump Peristaltic, 8-45 gpd, Sekokem, Defoamer	\$872.00
8.749-862.0	Tube, Squeeze, Santoprene, PR-7, 8-45 gpd	\$63.00
8.749-864.0	Tube, Squeeze, Santoprene, PRS-1, 1-7 gpd	\$26.50
8.749-860.0	Check Valve, Seko	\$57.50
8.749-863.0	Strainer with Weight, Seko	\$18.10
8.715-378.0	VSP20 Metering, 24V	\$967.00
8.715-379.0	VSP20 Metering 120V	\$986.00
8.749-856.0	Pump, Peristaltic, 1-7 GPD	\$858.00
8.749-855.0	Pump, Peristaltic, 8-45 GPD	\$858.00
8.750-963.0	Squeeze Tube, Sekokem, Defoamer 8-45 GPD	\$104.00

ARO Pumps

- Heavy-duty air diaphragm
- Corrosion resistant



ARO PUMP

Part No.	Description	List Price
8.715-278.0	Air Diaphragm, ½" Polypropylene	\$2,065.00
8.715-279.0	Air Diaphragm, ½" Stainless Steel	\$4,825.00

Jacuzzi Cyclone Pumps & Repair Kits

Part No.	Description	List Price
8.715-383.0	¾ hp 115/230V 1PH, Cyclone	\$978.00
8.715-382.0	½ hp 115/230V 1PH, Cyclone	\$933.00
8.716-796.0	Repair Kit, Impeller Kit (¾ hp Cyclone)	CALL
8.716-793.0	Repair Kit, Impeller Only (¾ hp Cyclone)	CALL
8.716-795.0	Repair Kit, Impeller Kit (½ hp Cyclone)	\$142.00

StaRite Pumps & Repair Kits

Part No.	Description	List Price
8.723-198.0	2 hp 230V 1PH, StaRite	\$2,030.00
8.917-759.0	¾ hp 115V 1PH, Ozone	\$657.00
8.917-760.0	¾ hp 230V 1PH, Ozone	\$1,015.00
8.723-219.0	¾ hp 208-230/460V 3PH, Ebara	\$1,420.00
8.749-351.0	Repair Kit, IShaft Seal Kit (for 8.723-198.0 only)	CALL
8.750-017.0	Repair Kit, IMech. Seal Ebara (For 8.723-219.0)	\$174.00
8.726-025.0	¾ hp 115V 48Y Motor	\$451.00
8.726-026.0	¾ hp 230V 48Y Motor	\$404.00
8.726-024.0	¾ hp, Center Discharge, Wet End Pump	\$284.00

Testing Kits

Part No.	Description	List Price
8.753-577.0	pH Test Strips	\$72.50
8.720-008.0	Water Test Strips, 5 Way	\$75.00

Regulators

- Preset and adjustable available
- Heavy-duty



Regulator

Part No.	Description	List Price
8.716-420.0	Regulator, Pressure w/ Gauge	\$143.00
8.717-748.0	Regulator, Rockwell ¾" 143-80 WB	\$436.00

Tanks & Pressure Tanks

- Internal bladder
- Compact design



Pressure Tank

Part No.	Description	List Price
8.719-176.0	Pre-pressurized, 4.4 gal	\$476.00
8.719-178.0	Pressurized, 20 gal	\$875.00

HBG / Combustion Box

- Cast in place fiberfrax insulation
- CAUTION: Double check operators manual to verify part numbers for sparger tube as they vary with different models



Firebox

Part No.	Description	List Price
8.717-434.0	Insulation, 1" x 2" HBG, /ft	\$18.10
8.913-195.0	Tank, HBG-15/99, Steel	\$5,530.00
8.913-196.0	Tank, HBG-15, 316L Stainless Steel	\$10,810.00
8.913-197.0	Tank, HBG-15/99, AL-6XN	\$40,580.00
8.913-223.0	Tank, HBG 30, Mild Steel	\$5,230.00
8.913-225.0	Tank, HBG 30, AL-6XN	\$60,270.00
8.913-198.0	Firebox, HBG-15	\$5,080.00
8.725-513.0	Switch, Level, Buckets	\$174.00
8.912-120.0	Fire Box, HBG-30	\$11,820.00

Water Blaster Unloader

- Preset and adjustable available
- Heavy-duty



Water Blaster Unloader

Part No.	Description	List Price
8.715-513.0	Unloader	\$748.00

Electrical Switches

- Waterproof
- Soft rubber feel
- Various designs



Rocker Switch

Part No.	Description	List Price
9.802-451.0	Rocker, Carling w/ Green Lens	\$23.20
9.802-453.0	Curvette, HBG 2-position	\$4.65
8.716-051.0	Curvette, 2-position Wide Switch	\$14.80
8.716-052.0	Curvette On-Off-On, HBG 3-position	\$4.60
8.716-091.0	Momentary Push, small	\$21.30
8.751-912.0	Block, Contact, N/C, CH E22B1	\$19.60
8.751-913.0	Block, Contact, N/O, CH E22B2	\$19.60
8.751-910.0	2-pos, CH E22Vb51, Carling w/ Light	\$33.00
8.718-200.0	Switch/ Gauge, Capsu-Photohelic Press, 0-10"	\$3,385.00

Float Switches

- Internal bladder
- Compact design



Float



Liquid Level

Part No.	Description	List Price
8.716-142.0	Float, N/O Tethered (Black)	\$96.50
8.716-143.0	Float, N/C Tethered (Gray)	\$85.50
8.716-294.0	Liquid Level, M-5000 HBG	\$199.00
8.716-632.0	Liquid Level, LS1800, Alpha	\$322.00
8.716-300.0	Sensor, Capacitance, 3-point, WB	\$2,735.00
8.725-513.0	Switch, Level, Buckets	\$174.00

Fuses

- Various Sizes
- Industry standard design



FNM



FQR



KTK



MDL

Part No.	Description	Max Voltage	AMPS	List Price
9.802-463.0	FNM1/2	250V	0.5	\$5.80
8.716-173.0	FNM1	250V	1.0	\$5.80
9.803-977.0	FNM2-1/2	250V	2.5	\$5.65
8.716-194.0	FNM7	250V	7.0	\$6.05
9.802-460.0	FNM8	250V	8.0	\$5.55
9.802-465.0	FNQ-R-3	600V	3.0	\$10.40
9.803-663.0	KTK-R2	120V	2.0	\$10.40
8.716-180.0	KTK-R4	600V	4.0	\$10.60
9.804-050.0	KTK-R5	600V	5.0	\$10.50
8.716-170.0	MDL1/2	120V	0.5	\$6.05
8.716-174.0	MDL2-1/2	24V	2.5	\$3.95

Indicator Lights

- Long lasting
- High intensity bulb



Red Indicator Light

Part No.	Volts	Color	List Price
8.716-095.0	125V	Red	\$13.20
9.802-455.0	125V	Green	\$12.40
8.716-408.0	125V	Amber	\$11.40
8.716-409.0	125V	Blue	\$14.80
9.803-650.0	28V	Blue	\$15.20
9.803-652.0	28V	Green	\$12.30

High Temp Cut-Out Switch

- High temperature rated



Thermocouple

Part No.	Description	List Price
8.712-172.0	Switch, Manual Reset, 220°F WB	\$95.00
8.754-117.0	Hi Limit Control, 1000°F, HBE, WB	\$592.00
8.712-175.0	Thermocouple, SS Sheath, 34" Long, Type K, HBG	\$232.00

Pressure Switches

- Adjustable set point
- Stainless steel body
- Diaphragm design



Pressure Switch

Part No.	Description	List Price
8.716-154.0	Square D, N/C Use w/ 2-10893, 2-1072	\$113.00
8.716-156.0	PM11120A-1PF, 1 PSI	\$111.00
8.716-158.0	PM11160X-15PR, 15 PSI	\$100.00
8.716-413.0	Barksdale, Air Proving	\$265.00

Relays

- Din rail mountable



RH2B-UL-AC120 Relay

Part No.	Description	List Price
8.752-146.0	Relay Socket, SH3B05*IDEC	\$8.90
9.802-468.0	Relay, 120V, RH2B-UL-AC120	\$31.10
8.752-141.0	Relay Latch 2, RH2LBUAC120*IDEC	\$83.00
8.716-235.0	Relay, Power Omron G4B112T1FDCUSRPAC120	\$321.00
8.716-264.0	Relay, Sky Mfg. 120V # SKHT-1X	\$42.60
9.802-467.0	Base, Relay, SH2B-05, IDEC	\$27.90

Ball & Gate Valves

- PVC Schedule 80
- Heavy-duty



1½" Slip x Slip Ball Valve

Part No.	Description	List Price
8.707-359.0	1" Slip x Slip	\$27.10
8.707-361.0	1½" Slip x Slip	\$65.00
8.707-362.0	1½" FPT x FPT Molded	\$58.00
8.707-343.0	Valve, PVC, 1", FIPT, Gate	\$97.50
8.707-344.0	Valve, PVC, 1.5", Slip x Slip, Gate	\$205.00
8.707-349.0	Valve, PVC, 2", Single Union Ball	\$195.00

Self Cleaning Screen

Part No.	Base Unit	Description	List Price
Special	600, 300	Self Cleaning Screen - Universal Clarifier System	CALL

Solenoids

- Preset and adjustable available
- Heavy-duty
- Diaphragm seat
- Corrosion resistant



Solenoid PVC 24V

Part No.	Description	List Price
8.716-689.0	Coil, 120V, Water Side	\$195.00
8.716-690.0	Valve, Parker, Water Side	\$600.00
8.716-691.0	Valve, Parker, Air Side	\$134.00
9.802-533.0	Solenoid Coil, 120V, Air Side	\$130.00
8.716-697.0	Solenoid, Water Maze, PVC 24V Rainbird	\$94.50
8.716-700.0	Solenoid, Valve 120V, Hit 310-100-1	\$158.00

Transformers

- Fuse Protected
- Heavy-duty



Transformer 240/480V

Part No.	Primary Voltage	Secondary Voltage	Size	List Price
8.716-873.0	208/120	.500KvA	50/60 Hz	\$486.00
9.802-550.0	240/480V	120/240V	.500KvA	\$351.00
9.802-551.0	240/480V	120V	.050KvA	\$111.00
9.802-553.0	120/240V	24V	.050KvA	\$118.00
9.803-668.0	550V/575/600V	115V	.050KvA	\$111.00
8.716-904.0	120/240V	24V	.100KvA	\$156.00
8.717-985.0	120/24V/30VA HBG-15			\$51.50
8.718-177.0	Ignition 612-6A020E 120V WB			\$341.00

Check Valves

- PVC Schedule 80
- Floating ball design



1 1/2" Ball Check Valve

Part No.	Description	List Price
8.707-297.0	1 1/2" Ball, PVC, Slip x Slip	\$336.00
8.707-300.0	1" Ball, PVC, Slip x Slip	\$174.00
8.707-298.0	1/2" Ball, PVC, FPT x FPT	\$142.00
8.707-299.0	1 1/2" Swing, PVC, Slip x Slip	\$81.00
8.707-239.0	2" Swing, Brass, FPT x FPT WB	\$482.00
8.707-355.0	3/8" Tubing, Checkvalve Ozone	\$31.00
8.707-356.0	1/4" NPT, FPT x FPT	\$41.00

Unions

Part No.	Description	List Price
8.706-597.0	Union, 1", Slip x Slip, Spears	\$21.40
8.706-469.0	Union, 1.5", Slip x Slip, Spears	\$46.50
8.706-470.0	Union, 1.5", Slip x FIPT, Spears	\$104.00
8.706-471.0	Union, 1", Slip x FIPT, Spears	\$24.80
8.706-472.0	Union, 1.5", FIPT, x FIPT, Spears	\$75.00
8.706-473.0	Union, 2", Slip x Slip, Spears	\$65.50
8.706-474.0	Union, 2", Slip x Slip, CPVC, Spears, WB	\$142.00
8.706-476.0	Union, 2", Slip x FIPT, Spears	\$123.00

Timers

- Various designs
- User Friendly



Counter

Part No.	Description	List Price
9.802-283.0	Hour Meter, 115VAC 60hz	\$64.00
8.716-236.0	Timer, Red Lion	\$1,370.00
8.716-237.0	Counter, Red Lion	\$1,170.00
8.716-253.0	Timer, 24 Hour Pin, 120V 20A	\$96.00
8.751-306.0	Timer, Multi-Function	\$120.00

FILTER CAPACITIES

* Per Cylinder

Model Number		Gravel 1/4 x 1/8	Garnet 30 x 40	Garnet 8 x 12	Sand .45-.55 m	Anthracite #1 .60-.80 mm	Carbon Activated	Element 100 sq/ft	Element 200 sq/ft	Element 250 sq/ft 20 micro	Zeolite 50 lbs
		8.718-921.0	8.718-923.0	8.718-924.0	8.718-920.0	8.718-922.0	8.718-933.0	8.716-872.0	8.716-840.0	8.716-847.0	8.757-147.0
CLP-5023	Current	100 lbs	—	—	150 lbs	25 lbs	100 lbs	—	1	—	—
CLP-5024	Current	100 lbs	50 lbs	50 lbs	50 lbs	25 lbs	100 lbs	—	—	—	—
CLP-7023	Current	100 lbs	—	—	200 lbs	30 lbs	150 lbs	—	—	2	2
	Prior to 2-01-00	100 lbs	—	—	200 lbs	30 lbs	150 lbs	—	2	—	—
CLP-7033	Current	350 lbs	—	—	450 lbs	100 lbs	160 lbs	—	—	2	2
	Prior to 4-05-01	400 lbs	—	—	500 lbs	100 lbs	225 lbs	—	—	2	2
	Prior to 2-01-00	400 lbs	—	—	500 lbs	100 lbs	225 lbs	—	2	—	—
	Prior to 2-22-99	100 lbs	—	—	200 lbs	30 lbs	150 lbs	—	2	—	—
CLP-7034	Current	350 lbs	300 lbs	200 lbs	100 lbs	100 lbs	160 lbs	—	—	—	—
CLP-8034	Current	200 lbs	100 lbs	200 lbs	50 lbs	50 lbs	160 lbs	—	—	—	—
	Prior to 8-29-01	300 lbs	—	—	300 lbs	50 lbs	225 lbs	—	—	—	—
CLP-9044	Current	350 lbs	300 lbs	200 lbs	100 lbs	100 lbs	350 lbs	—	—	—	—
	Prior to 8-29-01	400 lbs	—	—	500 lbs	100 lbs	600 lbs	—	—	—	—
CL-304	Current	100 lbs	—	—	200 lbs	30 lbs	—	1	—	—	—
Filter Pac I	30-780	—	—	—	—	—	150 lbs	—	1	—	—
Filter Pac II 30-779	Current	—	—	—	—	—	160 lbs	—	—	2	2
	Prior to 8-31-01	—	—	—	—	—	225 lbs	—	2	—	—
Filter Pac III 30-778	Current	100 lbs	—	—	200 lbs	30 lbs	150 lbs	—	2	2	2
	Prior to 5-20-04	100 lbs	—	—	200 lbs	30 lbs	150 lbs	—	2	—	—
REC-ZCF3-30A*	Current	50 lbs/cyl	—	75 lbs/cyl	—	—	—	—	—	—	250 lbs/cyl

COMPATIBLE SUMP PUMPS

Model Number	Little Giant 1/2 hp, 120V 8.715-367.0	Little Giant 1/2 hp, 230V/1ph 8.715-368.0	Little Giant 1/3 hp, 230V/1ph 8.715-369.0	Ebara SS 1/2 hp, 230V/3ph 8.715-438.0	Ebara SS 1/2 hp, 460V/3ph 8.715-439.0
CLP-7034A		■			
CLP-7034B				■	
CLP-7034C					■
CLP-5024A			■		
CLP-5024B				■	
CLP-5024C					■
CL-603A		■			
CL-600D	■				
CL-304A			■		
Alpha-1500D					
Alpha-3100D					

SHIPPING WEIGHTS AND DIMENSIONS



	Part #	Shipping Weight*	Shipping Dimensions* (L x W x H) Inches	Weight	Dimensions (L x W x H) Inches
Filtration / Recycle Systems					
	REC-ZCF3-30A	1.103-513.0	2,000 lbs	84 x 53 x 86	1,726 lbs 70 x 49 x 81
	ZCF Filter Pac	1.103-512.0	1,450 lbs	66 x 53 x 86	1,250 lbs 46 x 34 x 81
	Compact Coag	1.103-510.0	200 lbs	45 x 35 x 70.5	TBD 33 x 19 x 70.5
	IPF2-20D High Boy	1.103-488.0	370 lbs	46.5 x 40.5 x 47.56	336 lbs 46.5 x 40.5 x 47.56
	REC3-30A	1.103-511.0	525 lbs	58 x 41 x 66	325 lbs 38 x 31 x 53
In-ground Pit Systems					
	Collection Pit 3 x 9	8.903-657.0	550 lbs	125 x 52 x 66	302 lbs 120 x 46 x 55
	Collection Pit Cover	8.903-674.0/DP	140 lbs	Ship with pit	140 lbs 113 x 39 x 1
	Catch Basin 3 x 3	8.903-658.0	180 lbs	53 x 47 x 65	130 lbs 45 x 45 x 58
	Catch Basin Cover	8.903-678.0	50 lbs	Ship with pit	50 lbs 35 x 35 x 1
	Catch Basin Grating	8.903-677.0	150 lbs	Ship with pit	150 lbs 35 x 35 x 2
	Sump Basin 2 x 2	8.709-334.0	110 lbs	39 x 42 x 42	75 lbs 34 x 34 x 39
	Sump Basin Cover	8.903-675.0	35 lbs	Ship with pit	35 lbs 23 x 23 x 1
	Sump Basin Grating	8.903-676.0	70 lbs	Ship with pit	70 lbs 23 x 23 x 2
Oil/Water Separators & Clarifier Series					
	Alpha-1500D	1.103-401.0	545 lbs	92 x 46 x 34	325 lbs 80 x 36 x 32
	CLT-300	1.103-434.0	592 lbs	57 x 40 x 87	560 lbs 45 x 45 x 86
	CLT-600	1.103-435.0	1,000 lbs	65 x 72 x 100	835 lbs 55 x 55 x 104
BioSystems					
	PM-1000	1.103-467.0	175 lbs	21 x 30 x 46	165 lbs 35 x 21 x 47
	REC3-30A	1.103-511.0	525 lbs	58 x 41 x 66	325 lbs 38 x 31 x 53
Accessories					
	Grass Dumpster	8.903-602.0	99 lbs	55 x 28 x 36	85 lbs 55 x 28 x 36
Evaporators					
	HBG-30D	1.103-449.0	1,430 lbs	65 x 98 x 81	1,395 lbs 90.5 x 51 x 75
	WB-120A	1.103-473.0	2,240 lbs	80 x 55 x 81	1,690 lbs 68 x 40 x 80
	WB-50A	1.103-474.0	1,290 lbs	84 x 41 x 83	895 lbs 75 x 23 x 75
Water Blaster / Cannon Series					
	Water Blaster	1.103-484.0	681 lbs	49 x 27.5 x 48	500 lbs 42 x 59 x 62

* Shipping weights and dimensions approximate

COMPARISON MATRIX

Applications | Wash Water

Water Treatment Technologies Typically Applied to Application	pH Controller	Clarification/ Mechanical Separation	Filtration / Particle Separation	Coagulation/ Flocculation/ Bentonite Clay	Oil Separation/ Skimming	Coagulation & Flocculation	Coagulation/ Flocculation (Electro or Chemical)	Bioremediation	Water Evaporation	Ozone, Chlorination, Bioremediation for Odor Control
Water Characteristics Typically Generated by Application	Variable pH Control	Heavy Solids Separation	Particles (large and small)	Suspended Solids	Free Oils	Emulsified Oils	Heavy Metals	Dissolved Organics	Dissolved Inorganics	Malodorous Conditions
Page Number	40	36	40	25	32	25	25	45	48	45
Asphalt Paving Equipment	■	■	■	■	■	■		■	■	■
Auto Salvage	■			■	■	■	■		■	■
Automotive Automatic Wash	■		■	■		■			■	■
Automotive Detailing	■	■	■	■	■	■	■		■	■
Automotive Manual Wash	■		■	■				■	■	■
Boat and Shipyard Hull Cleaning Fluids	■		■	■			■	■	■	■
Diesel Engine Repair Ships	■				■	■	■		■	■
Farm Implement Equipment	■	■	■	■	■	■		■	■	■
Golf and Turf Equipment	■		■	■				■	■	■
Machinery Used	■		■		■	■	■		■	■
Material Handling Forklifts	■		■	■	■	■			■	■
Material Handling Wood Products	■	■	■	■				■		■
Mining Equipment	■	■	■	■					■	■
Oil Field Services Tool Repair	■	■	■	■	■	■	■		■	■
Oil Field Transportation Equipment	■	■	■	■	■	■	■		■	■
Rental Equipment Heavy Commercial	■	■	■	■	■	■		■	■	■
Rental Equipment Retail			■	■				■	■	■
Road Construction Equipment Excavators, Dozers, etc	■	■	■	■	■	■		■	■	■
Solid Waste Transport Landfill Equipment	■		■	■			■	■	■	■
State Department of Transportation	■	■	■	■	■	■		■	■	■
Trailer Repair	■		■	■	■	■	■		■	■
Transportation Aircraft	■			■			■		■	■
Transportation Locomotive	■		■	■	■	■	■		■	■
Transportation Motor Freight	■		■	■	■	■			■	■
Transportation Truck & Bus	■		■	■					■	■
Truck Dealers Heavy Duty	■		■	■	■	■			■	■
Truck Repair Heavy Duty	■		■	■	■	■	■		■	■

COMPARISON MATRIX

Applications | Industrial



Water Treatment Technologies Typically Applied to Application	pH Controller	Clarification/ Mechanical Separation	Filtration / Particle Separation	Coagulation/ Flocculation/ Bentonite Clay	Oil Separation/ Skimming	Coagulation & Flocculation	Coagulation/ Flocculation (Electro or Chemical)	Bioremediation	Water Evaporation	Ozone, Chlorination, Bioremediation for Odor Control
Water Characteristics Typically Generated by Application	Variable pH Control	Heavy Solids Separation	Particles (large and small)	Suspended Solids	Free Oils	Emulsified Oils	Heavy Metals	Dissolved Organics	Dissolved Inorganics	Malodorous Conditions
Page Number	40	36	40	25	32	25	25	45	48	45
Utilities Equipment Repair	■		■	■	■	■			■	■
Aircraft Refurbishment Fluids							■		■	
Cooling Tower Blow-down Water									■	
Die Casting Release Agent Fluids						■	■		■	■
Electroplating and Polishing Fluids							■		■	
Floor Scrubbing Water	■		■	■		■	■		■	■
Ground Water Remediation				■			■	■		■
Heat Treating Coolant Fluids							■		■	
Machine Shop Metal Cutting Coolants			■			■	■		■	■
Manufacturing Fluids Drawing Compounds						■	■		■	■
Metal Cutting Water Table Fluids Plasma Cutting			■	■			■		■	
Metal Finishing Surface prep Phosphate Cleaning Fluids	■		■	■		■	■		■	■
Metal Plating Fluids	■								■	
Metal Stamping Release Agents							■		■	■
Natural Gas Transmission Compressor Condensate					■				■	■
Parts Washing Fluids Aqueous Based	■		■		■	■	■		■	
Vibratory Bowl Cleaning and Polishing Fluids						■	■		■	■
Water Jetting and Cutting Fluids			■	■			■		■	

Note: Water contaminates and water characteristics may vary for each application. Please contact the Water Maze factory to discuss your specific water treatment application

Contact us for more information:

Water Maze

6398 N. Kärcher Way
Aurora, CO 80019
U.S.A.

Tel. 800-347-6116
Fax. 800-535-9164

info@wmaze.com
www.wmaze.com