

**UNITED STATES**

65 North Central Dr.  
O'Fallon MO, 63366  
Tel (636) 379-2226  
Fax (866) 659-8904  
Toll free (888) 808-9286  
Website  
[www.beer-co.us](http://www.beer-co.us)  
Email  
[info@beer-co.us](mailto:info@beer-co.us)



**CANADA**

1143 Haultain Court,  
Mississauga, ON, L4W2K1  
Tel (905) 629-2597  
Fax (905) 629-2577  
Toll free (866) 995-9965  
Website  
[www.beer-co.ca](http://www.beer-co.ca)  
Email  
[info@beer-co.ca](mailto:info@beer-co.ca)

**GLYCOL DECK  
OPERATION AND SERVICE MANUAL**

**H75G-3/8 Totton      H75G-3/8 Procon**



August, 2016

## INDEX

<b>TOPIC</b>	<b>Page</b>
1. Inspection	3
2. Installation Requirements	3
3. Specification	3
4. Replacement Parts	4
4.1. Overall Dimensions	5
4.2. Parts View Tayfun H75G Procon	6
4.3. Parts View Tayfun H75G Totton	7
5. Glycol Deck Set-up	8
6. Glycol Filling	8
7. System Start-up	8
8. Maintenance	9
9. Adjusting Digital Thermostat DIXELL	9
10. Air-cooled Condenser Cleaning	9
10.1. Bi-weekly Cleaning	10
10.2. Semi-annual Cleaning	10
11. Troubleshooting	11
12. Electrical Wiring Diagram :	13
12.1. Tayfun H75G Procon	13
12.2. Tayfun H75G Totton	14
13. Limited Product Warranty	15
13.1. Warranty Claim Form	18
14. Warranty Return Packing Instructions	19
15. Installation Notes	21

# **1. INSPECTION**

Each shipment should be carefully checked against the bill of lading or packing slip. The shipping receipt should not be signed until all items listed on the bill of lading have been accounted for. Check carefully for concealed damage. Any shortage or damages should be reported to the delivering carrier.

Damaged material becomes the delivering carrier's responsibility, and should not be returned to the manufacturer unless prior approval is given to do so.

**Warning: This equipment contains a refrigerant which may harm the public health and environment by destroying ozone in the upper atmosphere. Venting or release of certain refrigerants to the atmosphere is illegal. Refrigerant recovery devices must be used when servicing this unit. Consult your local codes for requirements.**

**Warning: Do not service this unit before disconnecting all power supplies.**

# **2. INSTALLATION REQUIREMENTS**

- **Dedicated power line, 115V, 60Hz, 15Amp.**
- **Recommended ambient temperature range 60-90F.**
- **Adequate air circulation as follows:**
  - **air condenser cannot be obstructed or covered in any way,**
  - **no filters allowed to be used with the unit.**

# **3. SPECIFICATION**

<b>Name</b>	<b>Unit</b>	<b>TAYFUN H75G PROCON</b>	<b>TAYFUN H75G TOTTON</b>
Part Number		H75-3/8GP	H75G-3/8VP
Maximum Distance	Ft	up to 125'	up to 75'
Capacity, (evap 20F)	BTU/hr	3200	3200
Glycol tank capacity	Gal	5.5	5.5
Dedicated Circuit	Amp	15	15
Voltage	V/Hz	115/60	115/60
Compressor Power	H/P	3/8	3/8
Thermostat	Type	Digital	Digital
Glycol Pump	Type	Fluid-o-Tech or Procon : 80gl/hr	Totton /FloJet/ SPC42-60W
Refrigerant	Type	R134a	R134a
Refrigerant amount	Lbs	0.375	0.375
Dimensions	Width, in	16.7	16.7
	Depth, in	15.4	15.2
	Height, in	30.7 / 35.8 (on legs)	29.7 / 34.8 (on legs)
Weight (net/gross)	Lbs	91/102	82/93

## 4. REPLACEMENT PARTS

DESCRIPTION/ MODEL	TAYFUN H75G PROCON	TAYFUN H75G TOTTON
Compressor	Tecumseh AE4450Y-AA or Embraco : NEU6212Z or NEK6212Z	
Start capacitor	for Tecumseh : 324-389 $\mu$ F/165-182V or for Embraco <u>NEU6212Z</u> : 189-227 $\mu$ F / $\geq$ 250V or for Embraco NEK6212Z : 189-227 $\mu$ F /250V	
Start relay	for Tecumseh : RP7338 (current relay), Optional: 9660C-***-187 (current relay) Or for Embraco <u>NEU6212Z</u> : 9660C-3027-189 Current relay),Optional: MTRPH70(current relay) or for Embraco <u>NEK6212Z</u> : 9660C-3027-189 (current relay), Optional: MTRPH70(current relay)	
Thermo overload relay	for Tecumseh : T988100-33 or for Embraco <u>NEU6212Z</u> : T0736, Optional : MSP00AFK, T0793, ST00AFZ or for Embraco <u>NEK6212Z</u> : T0625, Optional: MRP20JZ, MRT16AFN, T0838, T0793/**, MST16JN, VST16AFN	
Condenser	"Karyer" STFT-14221	
Condenser fan	"ELCO" NU 9-20-2/094 or "EBM" M4Q045-CA-27-04	
Pump motor	REGAL BELOIT AMERICA INC, Marathon 5KH32FN5586MX, (AC115V/60Hz)	YDK80/60-2-90A3
Pump	Fluid-o-Tech : PA2501 or PROCON : 102A080F11BC	Totton /FloJet/ SPC42
Power switch	Arcoelectric C6053AL (20A)	
Digital thermostat	Dixell XR02CX-4N0F1 (115V, 60Hz, 20A) or any similar UL-recognized	

## 4.1. OVERALL DIMENSIONS TAYFUN

### H75G PROCON:

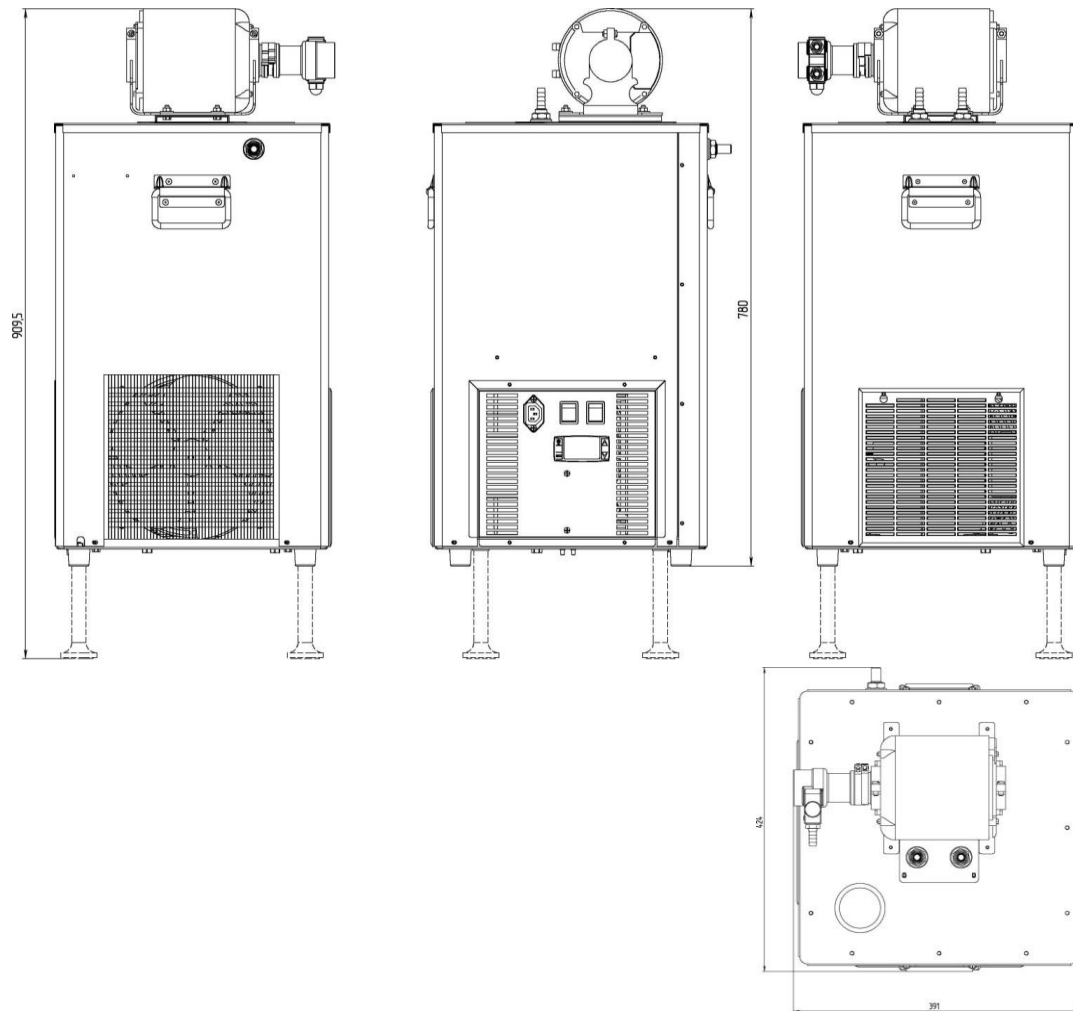

# TAYFUN H75G TOTTON:

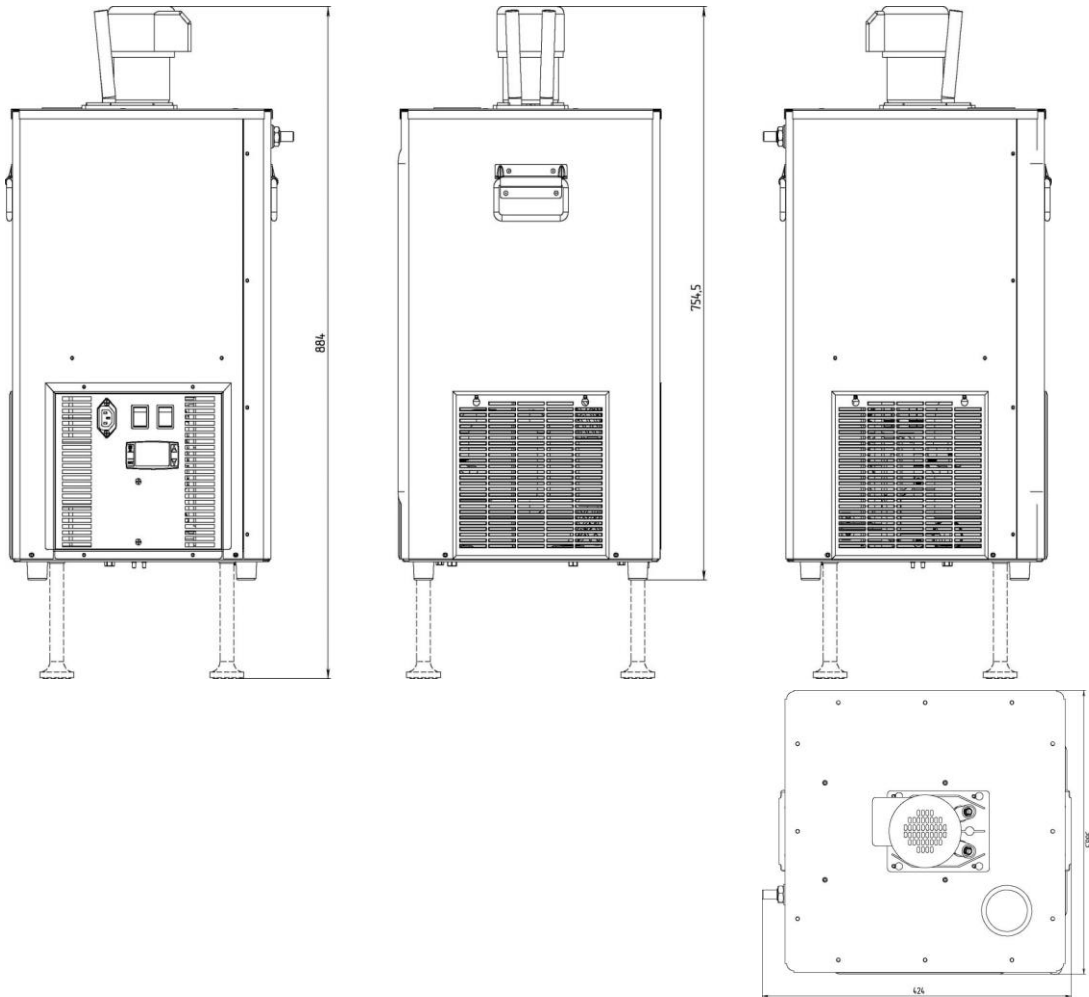

## 4.2. PARTS VIEW TAYFUN H75G PROCON

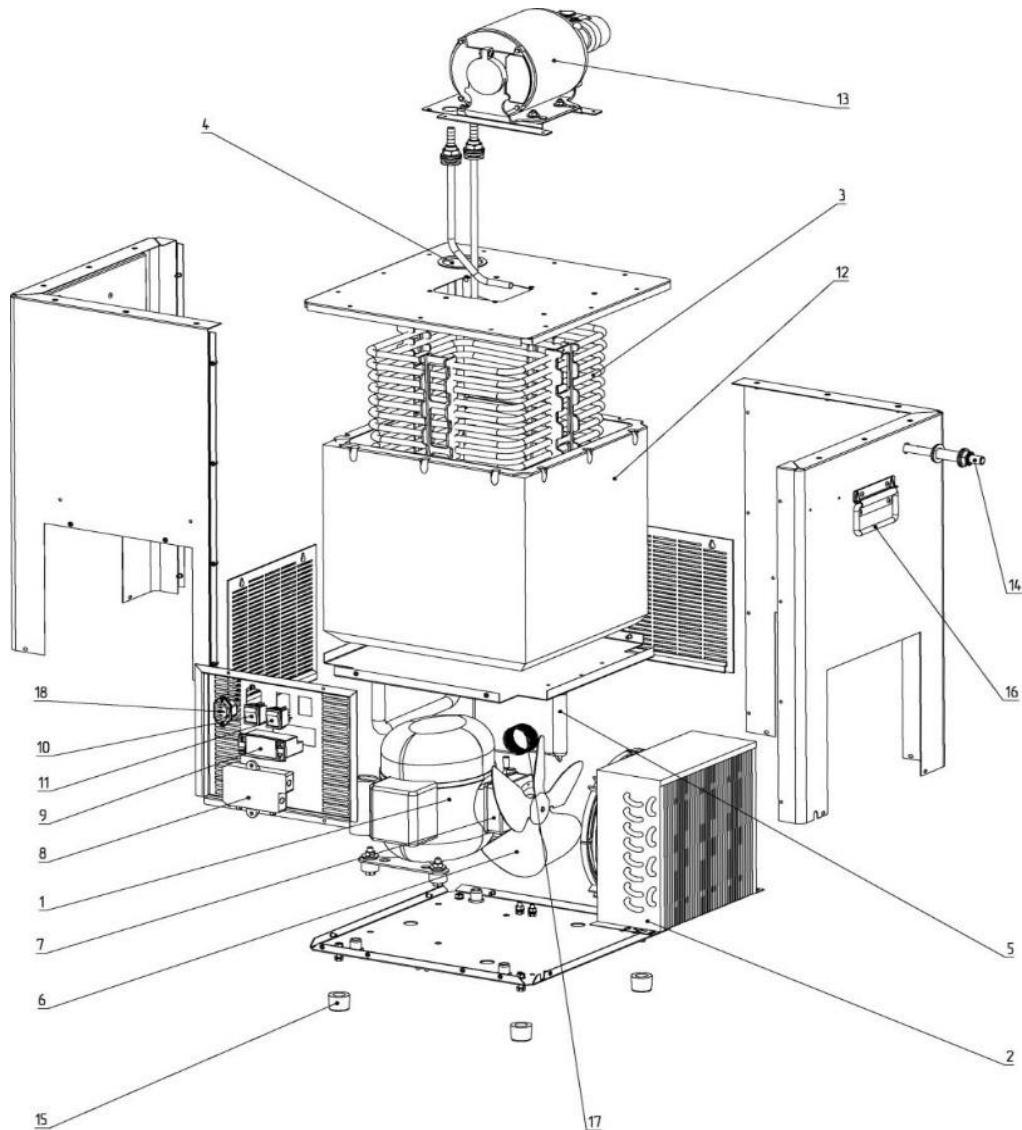

- |   |                    |    |                         |
|---|--------------------|----|-------------------------|
| 1 | COMPRESSOR         | 10 | POWER SWITCH /Red/      |
| 2 | AIR CONDENSER      | 11 | POWER SWITCH /Green/    |
| 3 | EVAPORATOR         | 12 | GLYCOL TANK             |
| 4 | CAP                | 13 | GLYCOL PUMP and PUMP MC |
| 5 | DRIER FILTER       | 14 | OVERFLOW                |
| 6 | IMPELLER           | 15 | FOOT                    |
| 7 | CONDENSER FAN      | 16 | HANDLE                  |
| 8 | TERMINAL BLOCK     | 17 | THROTTLE                |
| 9 | DIGITAL THERMOSTAT | 18 | CONNECTOR R302SN        |

### 4.3. PARTS VIEW TAYFUN H75G TOTTON

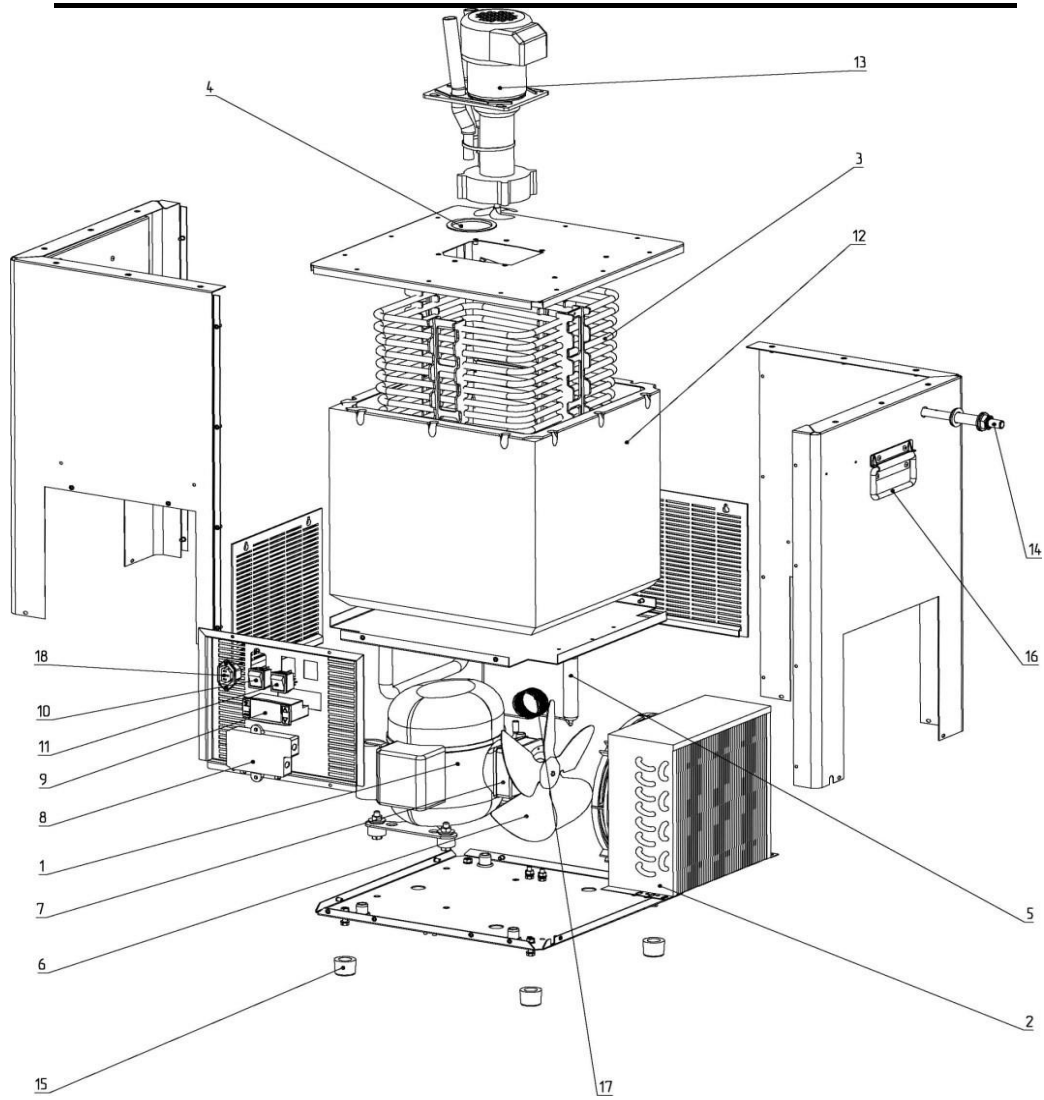

- |    |                    |   |                            |
|----|--------------------|---|----------------------------|
| 9  | COMPRESSOR         | 1 | POWER SWITCH /Green/       |
| 10 | AIR CONDENSER      | 2 | GLYCOL TANK                |
| 11 | EVAPORATOR         | 3 | GLYCOL PUMP: TOTTON SPC-42 |
| 12 | CAP                | 4 | OVERFLOW                   |
| 13 | DRIER FILTER       | 5 | FOOT                       |
| 14 | IMPELLER           | 6 | HANDLE                     |
| 15 | CONDENSER FAN      | 7 | THROTTLE                   |
| 16 | TERMINAL BLOCK     | 8 | CONNECTOR R302SN           |
| 17 | DIGITAL THERMOSTAT |   |                            |
| 18 | POWER SWITCH /Red/ |   |                            |



## **5. GLYCOL DECK SET-UP**

Once the survey of the location has been completed to determine the positioning of the glycol deck and the connecting draft beer dispensing stations (refer to the specifications sheet to be certain that the trunk line will be within the recommended distance), make the necessary provisions to place the unit and provide for the electrical services.

The ideal set-up is to mount the glycol deck on a proper equipment stand that is easily accessible for routine maintenance and service.

**NOTE:** Do not place the glycol deck in the walk-in cooler, as the cold ambient temperature will reduce the cooling performance of the unit.

**NOTE:** A minimum of twelve inches of clearance should be allowed around the entire unit for proper performance. Additional clearance should be considered for optimal performance and serviceability.

## **6. GLYCOL FILLING**

The glycol tank capacity is 7 Gal.

Only **food graded PROPYLENE GLYCOL** should be used with this unit. The recommended glycol/water mixture is: **40% glycol and 60% water.**

In some cases the glycol ratio can be increased up to 50% per installer's discretion.

**NOTE:** Do not place full strength glycol (undiluted) in the tank, as it will reduce the efficiency of the refrigeration system and may result in damage to the recirculation pump due to increased viscosity of cold glycol. The glycol ratio in the mixture should never exceed 50%.

**NOTE:** Select and use only a propylene glycol product that meets FDA (Food and Drug Administration) regulations as a food grade product. Any substitution of food grade glycol with automotive anti-freeze or other products will expose people to hazardous chemicals.

Fill the tank with glycol by removing the black plug on the deck lid and placing a funnel in the fill hole. Pour in the glycol mixture until all evaporator coils are covered. After glycol circulation startup some glycol should be added to cover coils.

**NOTE :** Always inspect the glycol tank for any debris as such might damage the pump.

## **7. SYSTEM START-UP**

It is a good practice to operate the glycol recirculation system for sixty (60) minutes before running beer through to the dispensing tap. This enables the glycol circuit to be checked for leaks. Also, recirculation of cold glycol through the lines enables the temperature inside the trunk line to stabilize before beer is introduced.

Once the refrigeration unit and the glycol recirculation pump have operated for sixty (60) minutes or more, the beer product can be connected and drawn through the trunk line.

Check the system for leaks.

Thoroughly insulate all line joints in the trunk line and dispensing taps.

It is recommended that the glycol lines be insulated inside the walk-in cooler to prevent excessive ice buildup. Insulate the glycol lines all the way up to the sealed chase way as it exits the walk-in cooler.

## **8. MAINTENANCE**

1. Inspect the unit monthly to ensure that the glycol level is maintained to the fill level.
2. If the level is low, check the mixture ratio with a refractometer then add the proper volume of glycol/water mixture to maintain the recommended mixture in the tank.
3. If there is evidence of ice buildup in the unit, allow the ice to melt and replace all the water/glycol solution with a fresh solution.
4. The water/glycol solution should be changed approximately every 18 months. In regions of high humidity it is recommended to replace the mixture on an yearly basis
5. Check and clean the condenser using a nonmetal brush every week, and using an air compressor or a vacuum cleaner every six months. Please check our instructions below.
6. Check for proper air flow through the unit ensuring enough clearance around it is allowed. There must be no obstructions in front of the air flow vents especially any sort of filters in front of the condenser unless approved by UBC.
7. Check the condition and effectiveness of the trunk line insulation.

## **9. ADJUSTING DIGITAL THERMOSTAT “DIXELL”**



### **DEFAULT SETTING VALUES**

<b>LABEL</b>	<b>NAME</b>	<b>RANGE</b>	<b>VALUE</b>
Set	Set point	LS - US	28
Hy	Differential	1 + 45°F	3
LS	Minimum Set point value	- 67°F + SET	15
US	Maximum Set point value	SET + 99 °F	45
Ot	Thermostat probe calibration	- 18 - +18°F	0
CF	Measurement units	F-C	F
Od	Outputs activation delay at start up	0-99	0
Ld	Default display	P1-P2-SP	P1

### **HOW TO CHECK THE SET POINT VALUE:**

1. Press and immediately release the SET key: the display will show the SET point value;
2. Press and immediately release the SET key: or wait for 5 seconds to display the probe value again;

### **HOW TO CHANGE THE SET POINT:**

1. Press and hold the SET key for more than 2 seconds to change the SET point value; 2. The value of the Set point will be displayed and the \* LED starts blinking;
3. To change the Set value press the ↑ (up) or ↓ (down) arrows.
4. To store the new set point value press the SET key again and wait 15 seconds.

### **HOW TO CALIBRATE THE THERMOSTAT PROBE:**

1. Enter the programming mode by pressing and holding the SET and ↓ (down) buttons together for 5 seconds, both \* LEDs will start blinking and the **HY** parameter will be displayed.
2. When the **HY** parameter is displayed immediately press and hold the SET and ↓ (down) buttons for a second time until The **Pr2** symbol is displayed only then release the buttons. The **HY** parameter will be displayed once more. You are now in the programming mode.
3. Select the parameter **Ot**;
4. Press the SET key to display its value.
5. Use ↑ or ↓ to change its value.
6. Press SET to store the new value.
7. To exit: press Set and ↑ buttons or wait 15 seconds without pressing a key.

NOTE: The chosen value is stored even if the programming is exited by waiting the 15 seconds to time out.

## **10. AIR-COOLED CONDENSER CLEANING**

UBC glycol chillers are equipped with special tubeless heat exchangers, manufactured with an innovative technology. This ensures the maximum capacity with the smallest size. Any condenser is prone to accumulate dirt and airborne dust that may reduce or block the air flow. To guarantee the cooling effectiveness and to prevent damage to other electrical components, the condenser must be cleaned regularly.

### **10.1. BI-WEEKLY CLEANING**

Step 1: Disconnect the power.

Step 2: Clean the condenser with a nonmetal brush, available at any Home Depot, Lowe's or any other hardware store.

For best results the condenser should be cleaned top-down (see picture).

Step 3: A finish soft brush or vacuum cleaning is recommended.

Step 4: Connect the power.

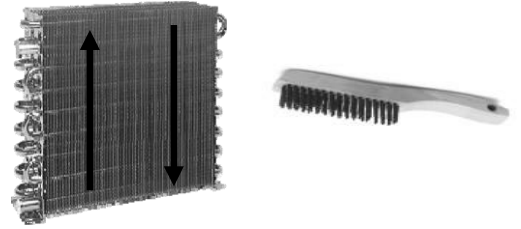

## **10.2. SEMI-ANNUAL CLEANING**

The bi-weekly condenser cleaning can only guarantee surface cleaning. Using a nonmetal brush it is impossible to reach and clean the funnel and between the funnel space. Only air blowing or deep vacuum cleaning can achieve proper cleaning results. To maintain high performance and efficiency, a semi-annual cleaning routine must be established. Please follow the instructions as described below:

Step 1: Disconnect the power.

Step 2: Clean the condenser with a nonmetal brush.

Step 3: Clean the condenser thoroughly using a pressurized air flow (portable air compressor) or a vacuum cleaner (see picture below). Check condenser cleanness using a flashlight.

Continue until compressor appears clean in between the fins.

Step 4: Connect the power and turn on the unit.



## **11. TROUBLESHOOTING**

PROBLEM	CAUSE	SOLUTION
Compressor does not start, no signal appears on the thermostat's front panel	No proper power supply	<ol style="list-style-type: none"> <li>1. Check the power (voltage) in receptacle</li> <li>2. Loose wiring. Check against the wiring diagram to locate and secure loosen wires.</li> </ol>
Compressor does not start, thermostat reads bath temperature, the fan motor is running	Inadequate low voltage to compressor usually caused by poor quality or non-dedicated power line	Measure voltage across common and run terminals on the compressor (shown on the compressor). Voltage must not drop below 90% of rated voltage. Turn off the system until proper voltage is restored.
	Wrong thermostat settings, or improper/loose	<ol style="list-style-type: none"> <li>1. Check thermostat settings such as set point and differential.</li> <li>2. Check contacts 9-10 on the thermostat</li> </ol>

	contact in the thermostat	
	Faulty thermostat	Check and replace the thermostat
	Start capacitor or start relay malfunction	Using a multimeter test the continuity of the start relay and then of the start capacitor. Replace relay if no continuity.
	Overload relay is not working properly	Check the relay using a multimeter. Replace the relay if no continuity.
	Compressor motor has a ground fault (also known as a short circuit to ground)	Replace the compressor
	Compressor is locked up	Replace the compressor
Compressor starts and runs, P1 is displayed on the thermostat	Probe failure or loose wiring	1. Check probe wiring 2. Replace probe
Compressor starts and runs for less than 1/2 minute and then shuts off	Inadequate Low voltage to compressor usually caused by poor quality or non-dedicated power line	Measure voltage across common and run terminals on the compressor (shown on the compressor). Voltage must not drop below 90% of rated voltage. Turn off the system until proper voltage is restored.
	Start relay not working properly, usually caused by overheating of the compressor due to poor air circulation through the air condenser, or inadequate low voltage	Using a multimeter test the continuity of the start relay. Replace relay if no continuity. Correct installation conditions such as air flow to condenser or proper voltage.
Compressor starts and runs more than 1 minute but shuts-off in less than 5 minutes	Inadequate Low voltage to compressor or fluctuating voltage; usually caused by poor quality or non-dedicated power line.	Measure voltage across common and run terminals on the compressor (shown on the compressor). Voltage must not drop below 90% of rated voltage. Turn off the system until proper voltage is restored.
	Faulty thermostat	Check thermostat for incorrect or erratic display signals and improper function. Replace if faulty.

	Compressor shuts off on overload relay (thermal protector).	<ol style="list-style-type: none"> <li>1. Check ambient conditions. Temperature must not exceed normal ambient operating temperature of 90°F</li> <li>2. Check condenser for adequate air flow, clean if necessary.</li> <li>3. Check condenser fan for operation, replace if faulty.</li> <li>4. Check the overload relay using a multimeter, replace if faulty.</li> </ol>
--	---	--

Compressor starts and runs more than 1 minute but shuts off in less than 5 minutes	Compressor shuts off on pressure switch. Thermostat displays “CA” error message.	<ol style="list-style-type: none"> <li>1. Check ambient conditions. Temperature must not exceed normal ambient operating temperature of 90°F</li> <li>2. Check condenser for adequate air flow, clean if necessary.</li> <li>3. Check condenser fan for operation, replace if faulty.</li> <li>4. Check the pressure switch using a multimeter, replace if faulty (no continuity)</li> </ol>
	Compressor motor has windings shorted, usually caused by overheating of the compressor due to poor air circulation through the air condenser; or inadequate low voltage to compressor usually caused by poor quality or non-dedicated power line	Replace the compressor and correct installation conditions such as air flow to condenser or proper voltage.
Unit runs OK, but shuts off before reaching the programmed set point	Wrong thermostat settings.	1. Check and reset Defrost Settings: “id” and “Md” values in thermostat programming.
	Faulty thermostat	Check thermostat for incorrect or erratic display signals and improper function. Replace if faulty.
	Faulty probe	Measure glycol bath temperature, compare to thermostat reading temperature, adjust probe or replace if faulty.

Unit operates long cycles or continuously	Wrong thermostat settings, such as: 1. SET POINT value is very low 2. Differential is too low or zero	1. Check and/or reset SET POINT (SET) 2. Check and/or reset DIFFERENTIAL (Hy)
	Limited air flow through the condenser	Check and clean the condenser.
	Unit is inadequate to meet BTU requirements of the system.	Upgrade the unit
	Improper installation of the unit or the system.	1. Examine and verify ambient conditions of the unit per product manual. 2. Examine the system for hot-spots. 3. Check the glycol pump for operation, replace if faulty.
	Low glycol level in the bath.	Check glycol level in the bath. Evaporator coils must be covered with glycol (fill level)
	Freon leakage	Locate and fix the leakage, then recharge with Freon. <b>*Must be only performed by a licensed refrigeration company *</b>
Pump makes abnormal noise and/or rattles PROCON PUMP ONLY	Loose V clamp– pump is not tightly secured to motor	Tighten V clamp
Unit rattles or vibrates during operation	Loose parts or mountings, compressor vibration	1. Place the unit on even surface 2. Identify sound or vibration source 3. Tighten screws or mountings if loose





## 12.2. TAYFUN H75G TOTTON

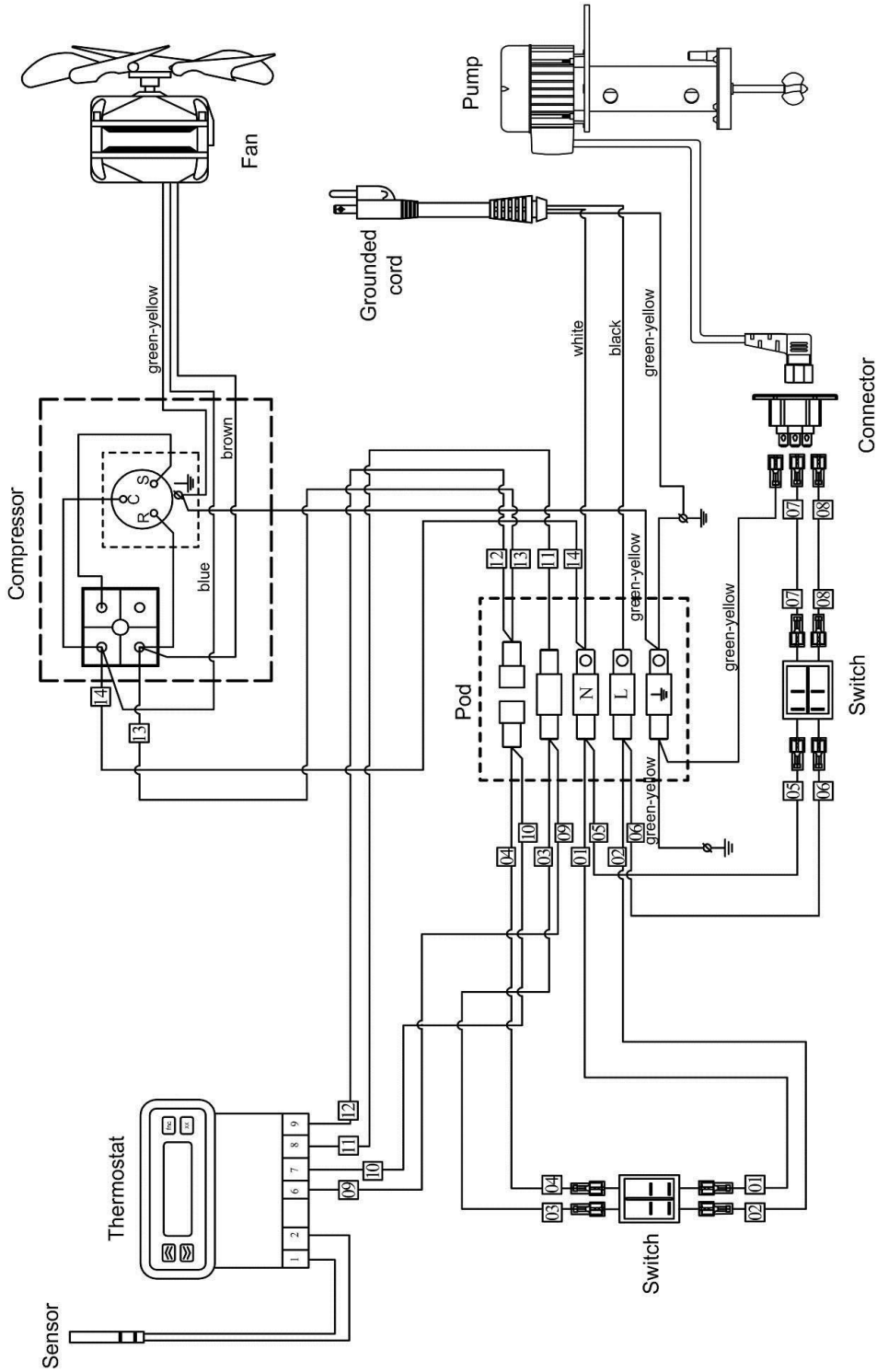

## **13. LIMITED PRODUCT WARRANTY**

For Full Warranty go to [beer-co.us/product-warranty](http://beer-co.us/product-warranty)

**UBC Group warrants that its products will be free from defects in material and workmanship, under normal use, regular service and preventative maintenance for 1 year from the date of sale. The warranty period for compressors is 5 years as described below.**

### **Prerequisites**

This warranty is available to the first end user for equipment purchased from UBC or UBC's authorized dealers. Equipment resold without such authorization will not be covered under this warranty.

All equipment must be properly installed according to guidelines found in the product manuals.

Approved usage conditions for operation must be provided as required in the product manuals (including but not limited to ambient conditions, dedicated power circuit and required clearance).

All equipment must be maintained and cleaned regularly as specified in the product manual.

In case of equipment failure customer must contact UBC group for a repair authorization number before any repairs are made. Warranty claim form must be completed in full and submitted to UBC Group within three months of repair. Some products which are not made by UBC Group are warranted by their respective manufacturer; therefore, this Limited Warranty does not apply to such products.

### **Warranty Period**

Warranty period is one (1) year from the date of installation but no longer than eighteen (18) months from date of sale. Compressor warranty period is five (5) years from the date of installation or sixty eight (68) months from the date of sale from UBC group. A warranty stub or documents of sale from distributor must be submitted for units not sold directly by UBC for warranty to be valid. The Warranty Claim form must be submitted within 3 months of completed repairs for claim to be valid.

### **Warranty Coverage**

#### **Refrigeration Units (including compressor)**

If a product is deemed defective by UBC group within the warranty period described above UBC group, at its discretion, will either repair or authorize the repair of the product. UBC group will be responsible for the labor charges according to the Labor Charges segment within the warranty period provided that all above mentioned prerequisites are satisfied. UBC group may also replace the product at its discretion bearing the labor costs for the product replacement according to the Labor Charges segment. The customer is responsible for the return of the defective part or product to UBC group for inspection and defect determination. Customer must package the part or product according to the instructions provided by UBC group before shipping it. UBC group will cover the shipping costs for the part or product as described in the Shipping segment of this warranty. Compressors are covered for an additional warranty for a period of four (4) years beyond the general coverage described above. Under the additional coverage if a compressor is deemed defective by UBC group, providing that all of the prerequisites described above are met, it will be exchanged for a new compressor. UBC group will **not** cover the labor charges associated with the compressor replacement. It is the responsibility of the customer to return the defective part to UBC group. The customer must return all parts of the compressor and package it according to the instructions provided by UBC group before shipping it. UBC group will cover the shipping costs

## **LIMITED PRODUCT WARRANTY (continued)**

for the part as described in the Shipping segment of this warranty. If the customer does not return the defective compressor to UBC group, than the warranty claim may be subject for denial. The customer has the option to send the unit to UBC group for compressor replacement and in this case will be responsible for all shipping charges. Furthermore, the customer will be responsible for the labor charges associated with UBC group changing the compressor. During this period, compressors can only be replaced once per unit.

### **Defect Determination**

UBC Group is the only body authorized to determine defects. Customers must contact UBC group to receive authorization for any course of action prior to any repairs. A warranty claim form must be completed and submitted to UBC group in order to process the claim and authorize any reimbursements. If a repair is made without an authorization number from UBC group it will not be covered by the warranty and will not be reimbursed. If UBC group sends a replacement prior to receiving the warranted chiller, and upon receipt the warranted chiller is not covered under warranty for any reason, then product owner is responsible for all shipping charges and the cost of the new product. All replacement parts not provided by UBC group must be pre-approved by UBC group prior to usage. If a part or product is authorized for return it is for inspection purposes only; if the defective part is not returned by the customer than the warranty claim may be subject for denial. It is the sole discretion of UBC group as to whether or not a credit/refund will be allowed. UBC group's determination of defects is final. If a problem occurs during non-regular business hours and a representative of UBC Group cannot be reached for authorization, then repairs may be made in protocol with our labor charges section. However, if UBC Group deems the repair unnecessary or if the damage is not covered by warranty, then UBC Group will deny the warranty claim.

### **Product Delivery**

The customer is responsible for inspecting units upon receipt for concealed damage caused during shipping. The customer must report damaged or non-working units or components to UBC Group immediately. Deliveries with physical damage should be denied. A claim must be filed with the carrier for any damages during shipping. UBC Group is not responsible for units damaged during shipping.

### **Warranty does not cover**

- Physical damage or water damage to the unit caused by negligence of the user.
- Improper installation and modifications made without UBC group's explicit approval.
- Chillers being used for applications which they were not originally designed for
- Damage resulting from electrical supply, water supply, drainage, flood, storm or any other incidents.
- Repairs made without the explicit authorization of UBC group and without the submission of the warranty claim form.

### **Note:**

UBC GROUP IS NOT RESPONSIBLE FOR ECONOMIC LOSS OR SPECIAL, INDIRECT, OR CONSEQUENTIAL DAMAGES, INCLUDING, WITHOUT LIMITATION, LOSSES OR DAMAGES ARISING FROM FOOD OR PRODUCT SPOILAGE CLAIMS AS A RESULT OF REFRIGERATION FAILURE.

### **Shipping**

During the warranty period UBC Group will be responsible for shipping charges as describe in the previous segments. UBC Group will ship replacement parts using standard ground shipping only. Refrigeration units will be shipped on pallets ground freight (LTL) only. If expedited shipping is needed the customer will incur the difference in shipping cost.

# LIMITED PRODUCT WARRANTY (continued)

## Labor Charges

Please present this schedule to the service company to avoid any labor charge misjudgments.

When submitting a bill for warranty work, the hours submitted must be within the guidelines listed below. The form is designed for a single claim for a single unit. If more units serviced additional forms are required. The time spent on the job should be multiplied by the straight time labor rate to determine the charge. UBC group reserves the right to pay no more than the average commercial hourly rates within the particular territory or region of the country. There is no provision for payment of a premium rate during "overtime" hours. UBC group will not cover any additional fees charges or material costs associated with a claim, with the exclusion of Freon gas if used to recharge the unit. To prevent delays in processing claims, a complete and detailed explanation of the diagnosis and repair is required. It is required that only certified technicians preform repairs on UBC group products, all other parties may void warranty. Parts must be supplied by UBC group. If parts cannot be obtained from UBC group, parts purchased from third party sources may be used only with UBC group's approval. Reimbursement of secondary parts will not exceed UBC group's internal pricing schedule. Use of unapproved parts will void the UBC group warranty. An invoice must be provided with the Warranty Claim form to receive compensation. **Under no circumstances should UBC group's liability for labor charges exceed the purchase price of the unit in the original invoice.**

### MAXIMUM LABOR TIME ALLOWED FOR A WARRANTY CLAIM

Travel time	1 hour
Diagnosis (check and determine the probable cause of the problem; allowed only once)	1 hour
Part replacement (thermostat, pump & motor, start relay, fan & motor, etc.)	1/2 hour
Refrigeration (detect a Freon leak, fix and refill Freon)	1 hours
Compressor replacement	3 hours
Unit replacement	2 hours

If the repair cannot be finished in one visit and a second visit is required another hour of travel time will be allowed. The maximum travel time for a single claim is two (2) hours.

### Instructions for completing form

- All fields must be filled out completely
- All parts replaced must be listed in the claim form
- Must be submitted in legible form (print)
- All claims MUST be submitted directly to UBC Group in order to receive reimbursement:

Email: [info@beer-co.us](mailto:info@beer-co.us)

Email: [info@beer-co.ca](mailto:info@beer-co.ca)

Fax: (866) 659-8904 Phone: (636)  
379-2226

Fax: (905) 629-2577  
Phone: (905) 629-2597

# 13.1. WARRANTY CLAIM FORM

**Please see instruction before completing form!**

Service invoice

Number (if attached) \_\_\_\_\_

Return authorization number \_\_\_\_\_

<b>Date malfunctioned</b>		<b>Date repaired</b>		<b>Date form completed</b>	
<b>Model number</b>		<b>Serial Number</b>		<b>Installation date</b>	
<b>SERVICE COMPANY</b> - Contact name, Phone, Full address			<b>CUSTOMER</b> - Contact name, Phone, Full address		

**COMPLAINT:**

\_\_\_\_\_

\_\_\_\_\_

\_\_\_\_\_

\_\_\_\_\_

\_\_\_\_\_

Symptoms and summary of diagnosis made are required. List hours and explanation for each repair made. Give exact location of any leaks.

<b>Service performed</b>	<b>Hours</b>

<b>Parts replaced or refrigerant used (type and amount)</b>	<b>Price</b>

If the problem cannot be fixed and the unit must be replaced please call UBC to obtain an authorization number prior to sending the unit for warranty claim.  
 Make sure to write that number on the top of this form.

**Labor Charges Summary**

Hours \_\_\_\_\_

Labor Rate per hour \_\_\_\_\_ \$      Subtotal hours \_\_\_\_\_ \$

Parts \_\_\_\_\_ \$

**GRAND TOTAL** \_\_\_\_\_ \$

CUSTOMER SIGNATURE \_\_\_\_\_

SERVICE TECHNICIAN SIGNATURE \_\_\_\_\_

## 14. WARRANTY RETURN PACKING INSTRUCTION

- All returns must be authorized by UBC prior to shipping. UBC will provide label with a ship to address once return is authorized, a warranty claim form must be completed and faxed to UBC.
- Warranty units must be shipped on a pallet and freight only.
- If you don't have the original packaging contact UBC to obtain one.
- Units sent without proper packaging will not be processed for warranty claims.

1. Wrap the entire unit with shrink wrap



2. Place the bottom pad on an even surface

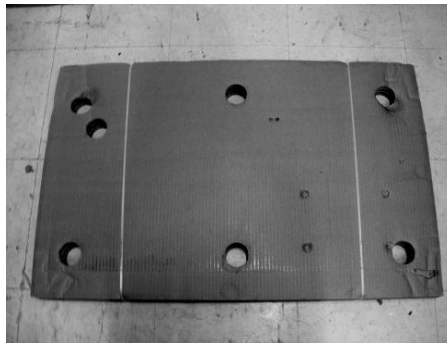

3. Place the unit on the bottom pad making sure it is centered



4. Place the box on top of the chiller.

5. Place the cardboard packing corners inside the box.

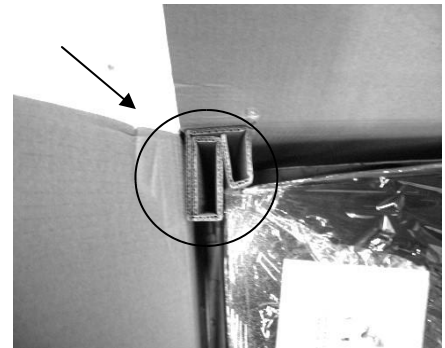

6. Close and seal the box with packaging tape



7. Fasten the box with 2 straps, one on each side as shown below. In the absence of original straps use customs.

8. Place the box on a pallet making sure it is centered. If shipping with other boxes make sure the box is entirely on the pallet

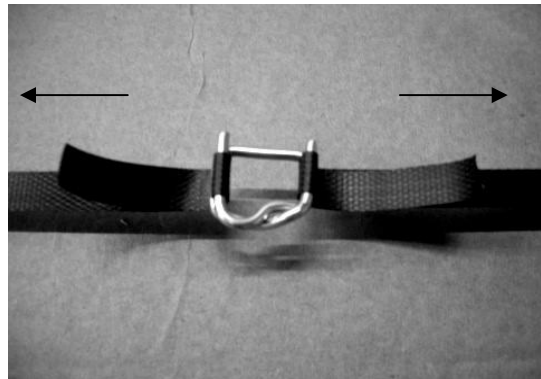
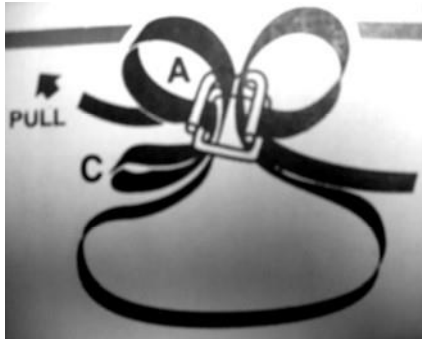

9. Secure the box to the pallet using straps, buckles or fasteners and strap guards. Make sure to fasten the strapping tightly to guaranty the box will not fall from the pallet during shipping. You may also use shrink wrap as long as the box is properly secured to the pallet.





10. Attach shipping labels and a “non-stackable” label



- The unit must always remain in its upright position, especially during shipping.
- Do not flip the unit or box on the sides or its top!

## **15. INSTALLATION NOTES**

Serial number: \_\_\_\_\_ Model Number \_\_\_\_\_

Installation date: \_\_\_\_\_

Installation address: \_\_\_\_\_

