

SPECIMEN CUP
MAXIMUM DIMENSIONS

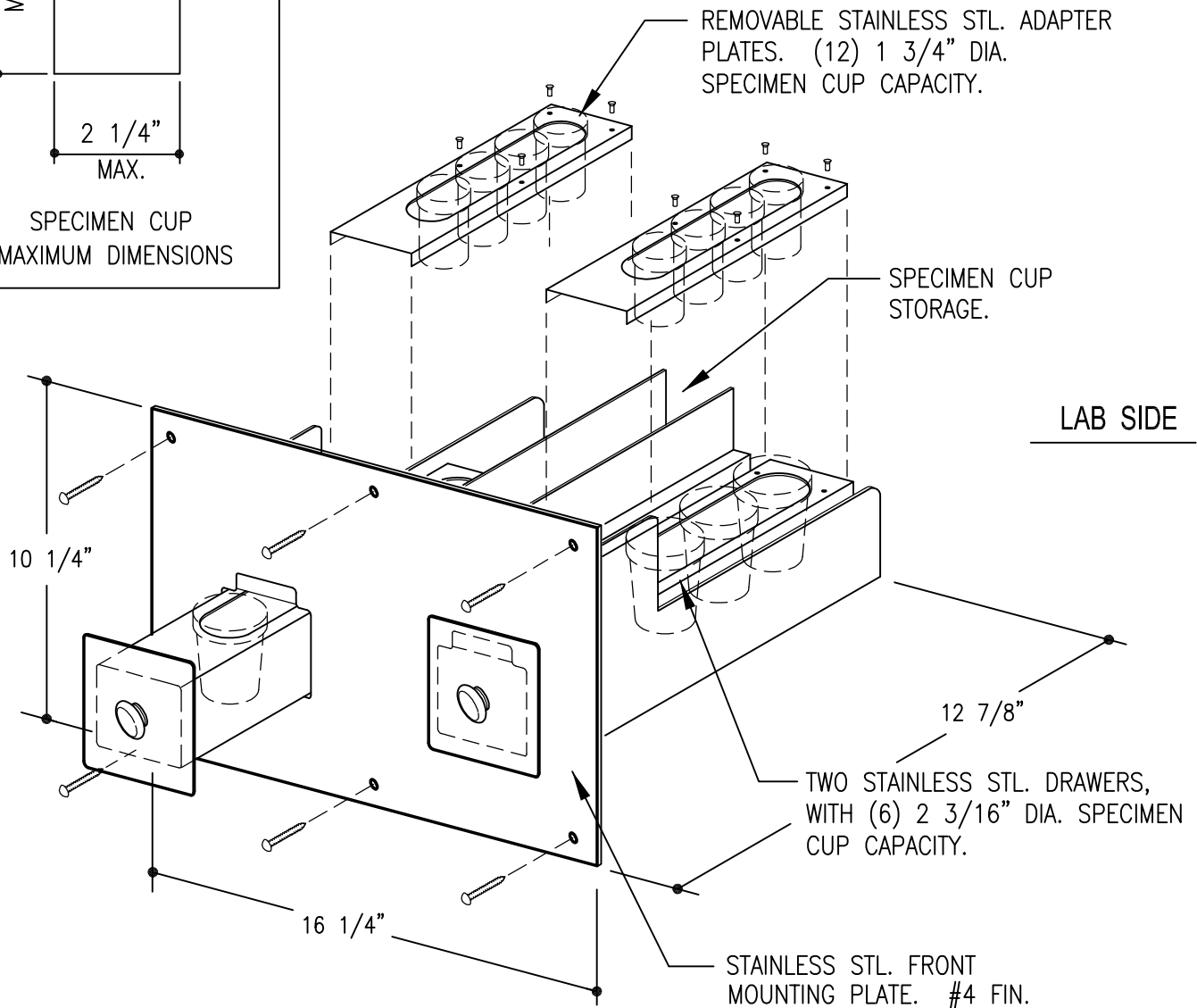

PATIENT SIDE

LAB SIDE

SPECIMEN PASS-THRU / MODEL UPPM-13.0

CAPACITY:

(6) 2 3/16" DIA. (2 17/32" DIA. CAP) x 3" HIGH SPECIMEN CUPS

CAPACITY WITH ADAPTER PLATES:

(8) 1 3/4" DIA. (1 15/16" DIA. CAP) x 3" HIGH SPECIMEN CUPS

This drawing is the property of Chaparral 1 Inc. and is loaned subject to the condition that it is not to be copied, reproduced or distributed either whole or in part and is not to be used directly or indirectly excepting under the supervision of Chaparral 1 Inc.. Nor may it be used in any way that is detrimental to the interests of Chaparral 1 Inc.



P.O. Box 11368
 Portalnd, OR. 97211 - 0368
 Ph: (503) 285-9553
 Toll Free Ph: (888) 246-9348
 Fax: (503) 285-9526
 Toll Free Fax: (877) 246-9526
 www.chaparralfixtures.com

SPECIMEN PASS-THRU
 MODEL UPPM-13.0

Date:
 9 - 15 - 16

Sheet
 1

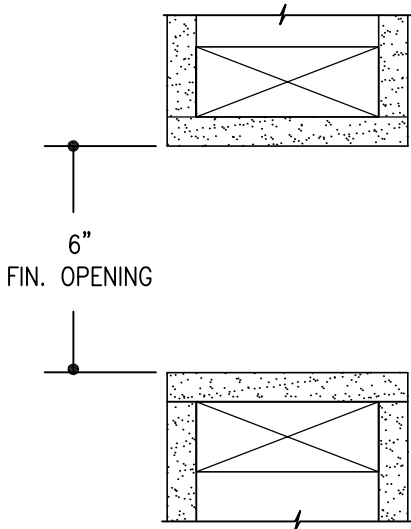
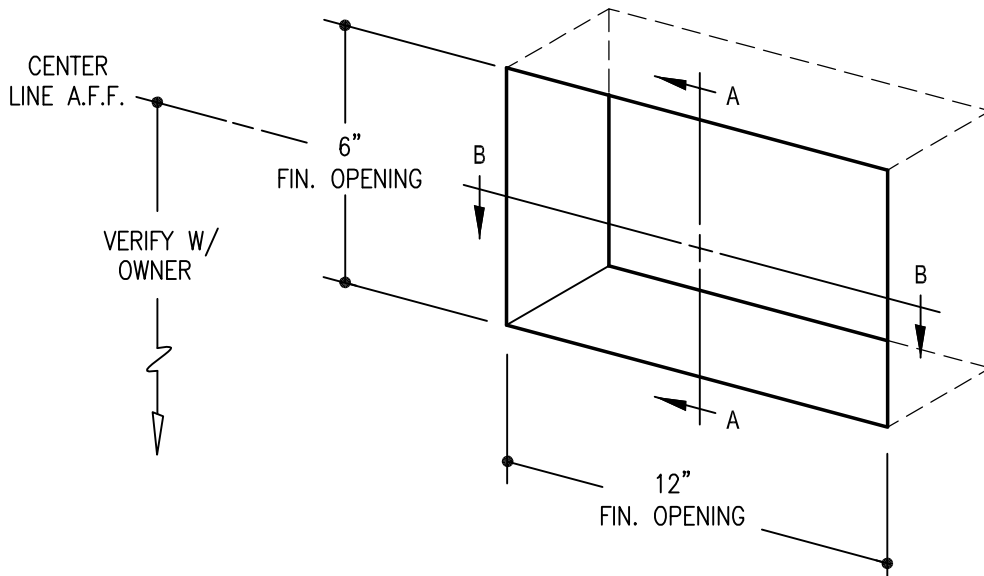

SECTION A - A

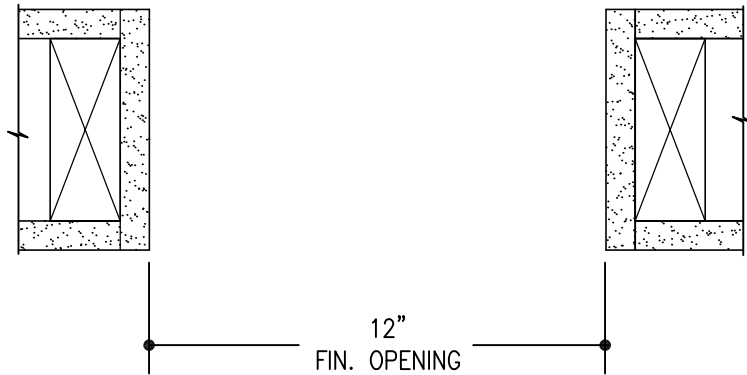

SECTION B - B

INSTALLATION INSTRUCTIONS

- 1) VERIFY WALL BACKING IS PROPERLY PLACED.
- 2) SLIDE UNIT INTO OPENING.
- 3) SECURE UNIT WITH 6 STAINLESS STL. FASTNERS.
FASTENERS INCLUDED, 2" L. X #10 TRUSSHEAD SCREWS.

This drawing is the property of Chaparral 1 Inc. and is loaned subject to the condition that it is not to be copied, reproduced or distributed either whole or in part and is not to be used directly or indirectly excepting under the supervision of Chaparral 1 Inc.. Nor may it be used in any way that is detrimental to the interests of Chaparral 1 Inc.

SPECIMEN PASS-THRU / MODEL UPPM-13.0

FINISHED WALL OPENING REQUIREMENTS & INSTALLATION INSTRUCTIONS.



P.O. Box 11368
 Portland, OR. 97211 - 0368
 Ph: (503) 285-9553
 Toll Free Ph: (888) 246-9348
 Fax: (503) 285-9526
 Toll Free Fax: (877) 246-9526
 www.chaparralfixtures.com

SPECIMEN PASS-THRU
 MODEL UPPM-13.0

Date:
 9 - 15 - 16

Sheet
 2