

**halliday  
baillie**

## HB 500 HANDRAIL BRACKET

The Halliday+Baillie HB 500 Handrail Bracket provides an easy-to-install solution for 1 ¼" to 2" diameter wood handrails.

Only suitable for interior or covered exterior situations. For exterior or marine environments, please specify the HB 510 stainless steel bracket.

Includes all fasteners. Epoxy sold separately.

**material** : non-anodized aluminum alloy

**maximum spacing** : 800 mm ( 31.50" )

**available in the following finish** :

**SC** : Satin Chrome

Custom Finishes are available upon request.

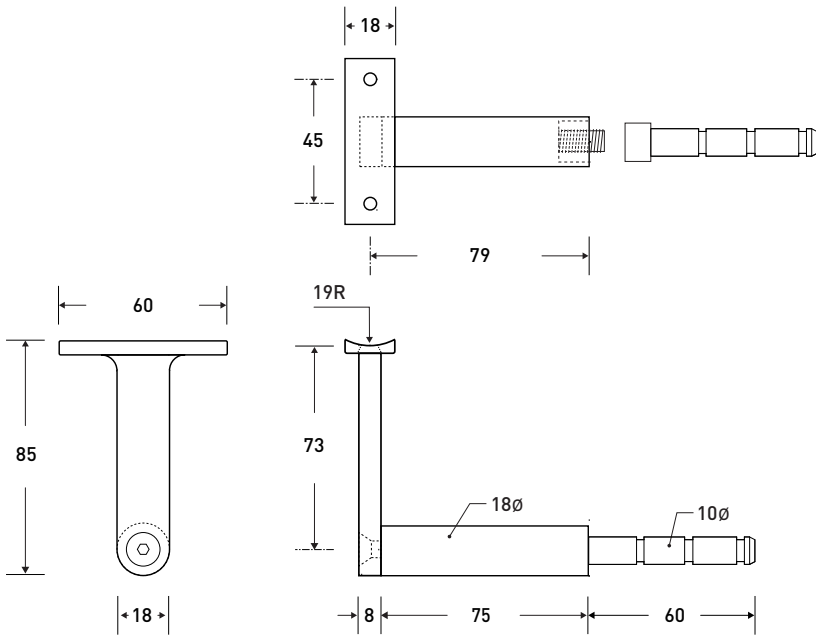

## HB 502 Glass Fixing Kit for HB 500 Bracket

Please specify glass thickness.

**recommended glass boring** : 19mm (.75" )

available in the following finish :

**SC** : Satin Chrome

