

PIVOT DOOR SYSTEMS

The FritsJurgens pivot door hinges stand out from other hinges in that all the technology is in the door. This makes the interface with the floor and the ceiling subtle and stylish.



Nothing in the floor or the ceiling



Very high bearing capacity



Maintenance-free system



Simple, fast fitting

SYSTEMONE



SYSTEM4



SYSTEM3



FRITSJURGENS SYSTEMONE

FritsJurgens SystemOne provides the required functionality for the fitting of a pivot door in a compact system. In contrast to the System3 and System4 this system does not have a closing mechanism or hold positions.



Can be used in doors upwards of 40 mm thick

Can be used with all types of FritsJurgens floor plates and top pivots.

Supplied as a complete set with top pivot, floor plate and ceiling plate and fitting accessories.

DIMENSIONS

Bottom pivot for SystemOne

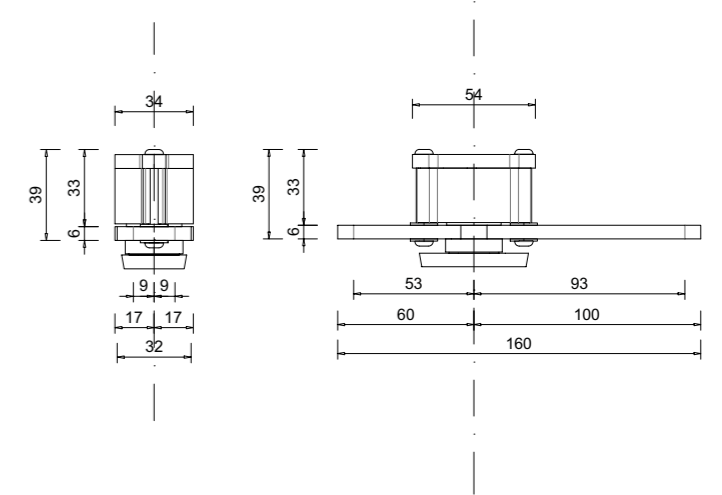

MILLING DRAWING

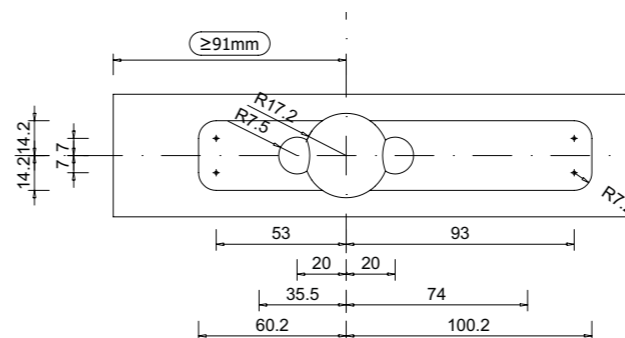
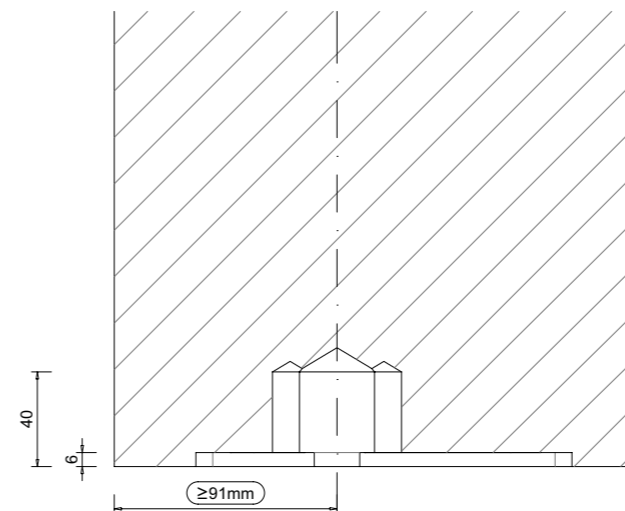

DIMENSIONS AROUND DOOR

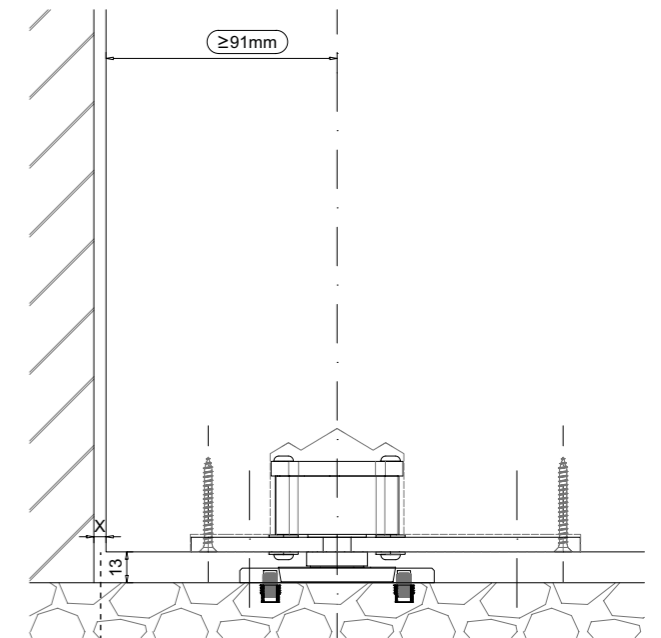

PIVOT DOOR SYSTEMS

The FritsJurgens pivot door hinges stand out from other hinges in that all the technology is in the door. This makes the interface with the floor and the ceiling subtle and stylish.



Nothing in the floor or the ceiling



Very high bearing capacity



Maintenance-free system



Simple, fast fitting

SYSTEM ONE



SYSTEM 4



SYSTEM 3



FRITSJURGENS SYSTEM 3 (MPDS-S80 F9000)

FritsJurgens System 3 is characterised by a hold position at 0°, 90°, 180° and 270°. This means that the door is spring-loaded and closes from each 45° in both directions and stops in the desired direction.



Hold position at 0°, 90°, 180° and 270°



Can be used in doors upwards of 40 mm thick

Can be used with all types of FritsJurgens floor plates and top pivots.

Supplied as a complete set with top pivot, floor plate and ceiling plate and fitting accessories.

DIMENSIONS

Bottom pivot for System 3

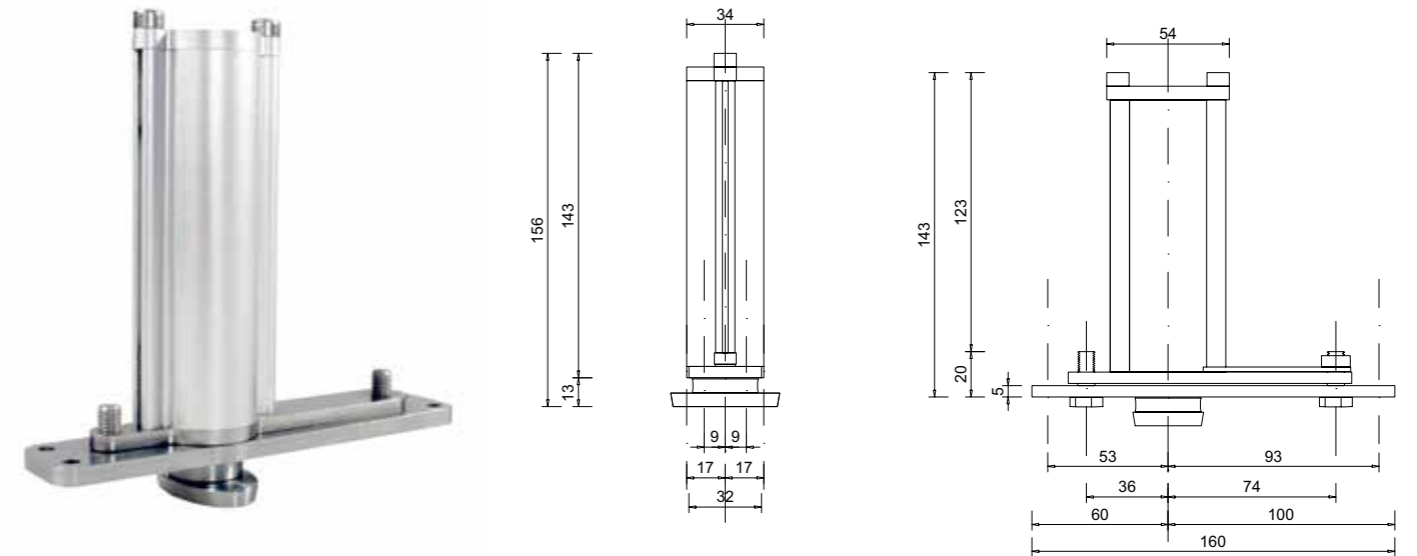

MILLING DRAWING

DIMENSIONS AROUND DOOR

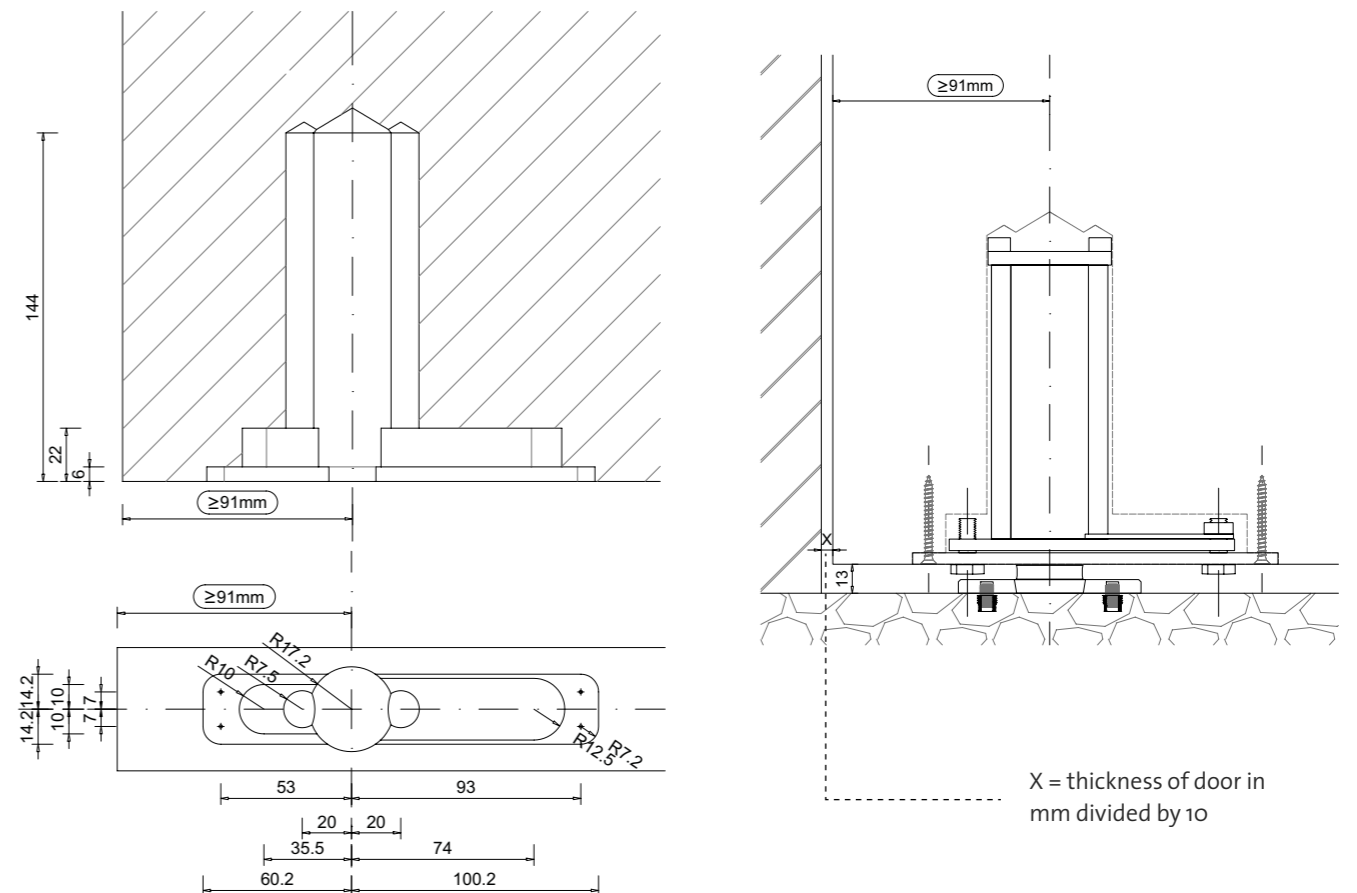

X = thickness of door in mm divided by 10

PIVOT DOOR SYSTEMS

The FritsJurgens pivot door hinges stand out from other hinges in that all the technology is in the door. This makes the interface with the floor and the ceiling subtle and stylish.



Nothing in the floor or the ceiling



Very high bearing capacity



Maintenance-free system



Simple, fast fitting

SYSTEMONE



SYSTEM4



SYSTEM3



FRITSJURGENS SYSTEM4 (M42-SC 1000)

FritsJurgens System4 stands out from other systems by virtue of the unique way in which the door closes. This pivot door system with infinitely variable closing force is suitable for doors up to 150kg. The system has a hold position at 90 and -90 degrees.



Damped closure



Adjustable closing force

Can be used with all types of FritsJurgens floor plates and top pivots.

Supplied as a complete set with top pivot, floor plate and ceiling plate and fitting accessories.

DIMENSIONS

Bottom pivot for System4

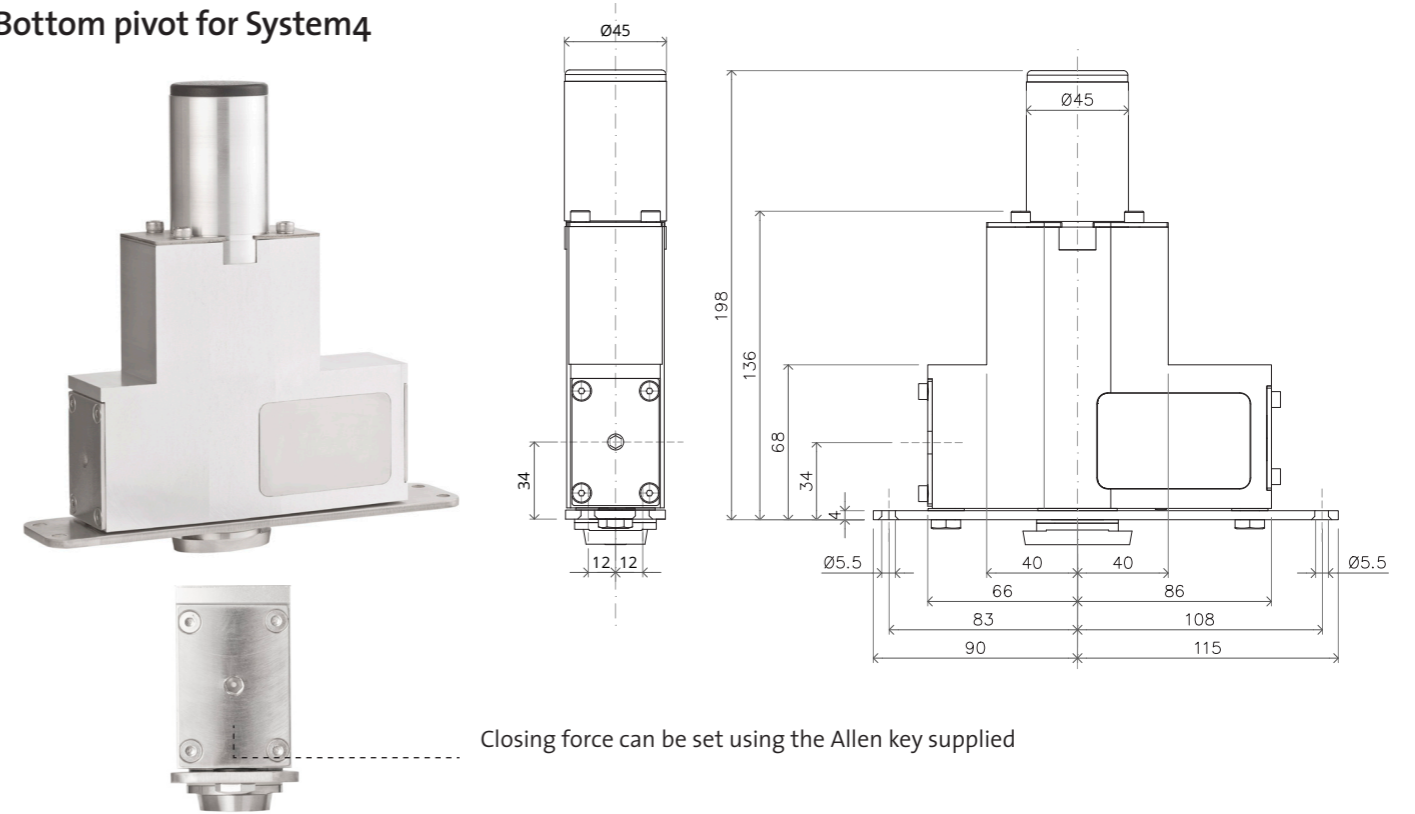

Closing force can be set using the Allen key supplied

MILLING DRAWING

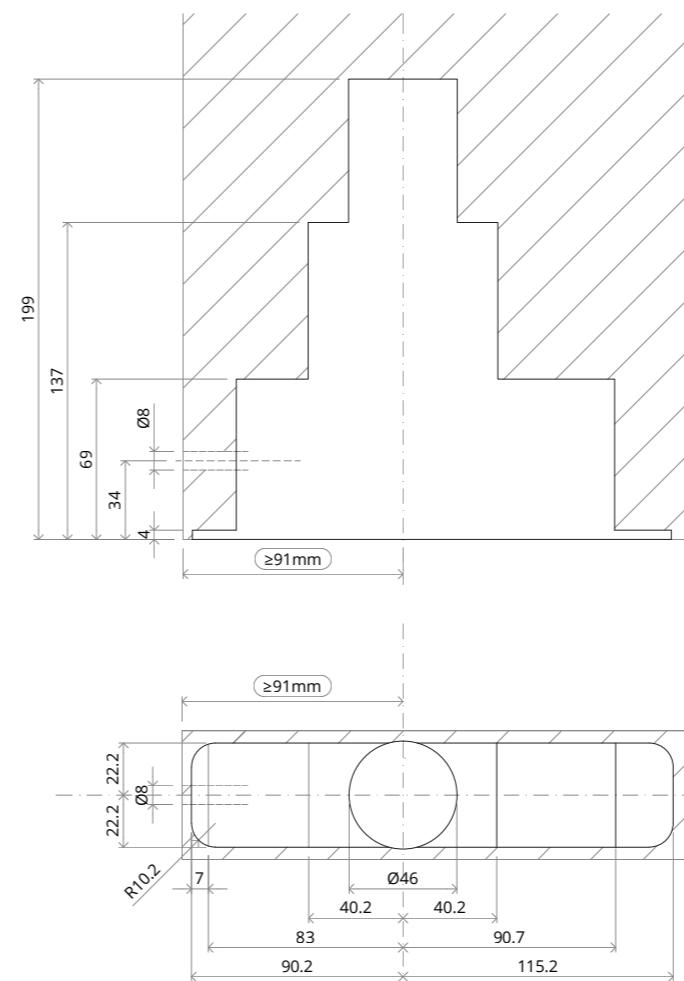

DIMENSIONS AROUND DOOR

