

# Mounting and Installation

RED Point to Bow

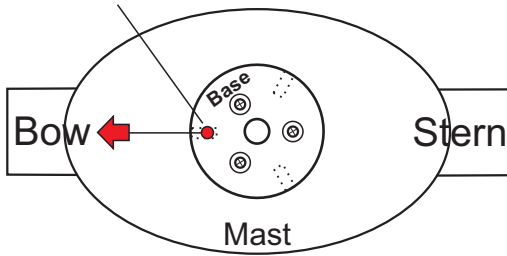

RED Point to Bow

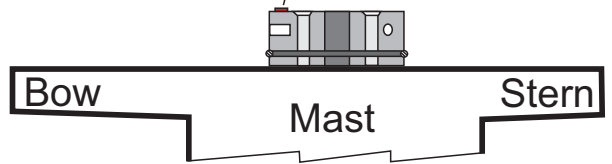

## Option 1

## Wires out-put option

Three 4mm Allen screw to fix de lamp on the base

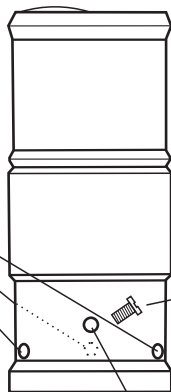

1-Remove the screw wires

WIRES:  
3 in the SW Model  
4 in the Classic Model

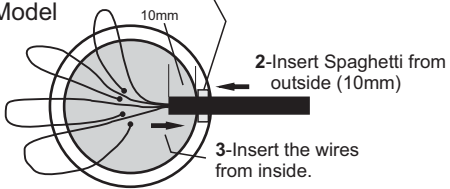

Bottom view

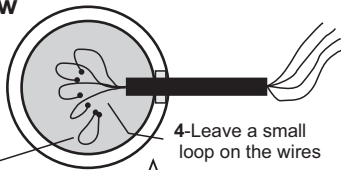

Strobe Light loop (violet wire - see the Instructions)

4-Leave a small loop on the wires

⚠ Do not put the wires loops one over the other

Allen screw in front of the lamp: to Bow

The wires should go down

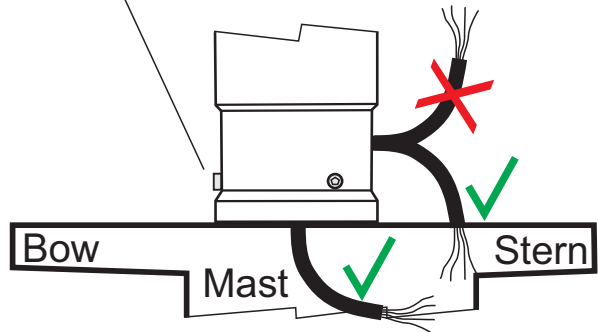

### Important:

- 1- Fixing the lamp on the base: hold the lamp only by the black body and NOT by the lens.
- 2- If necessary use the provided grease for the o´ring.
- 3- Sold the wires.

## Option 2

Bottom view

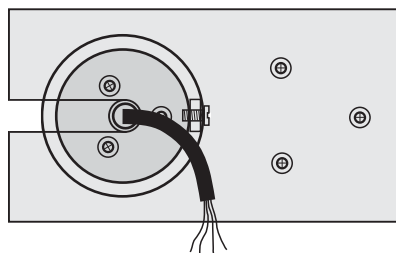

Braket aluminum or inox

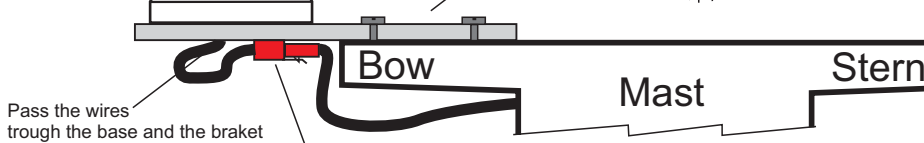

Pass the wires trough the base and the braket

Waterproof connector option (Only Amazonia Mirim 4 Model)

## AMAZÔNIA SW: WITH SWITCH - 3WIRES (with strobe)

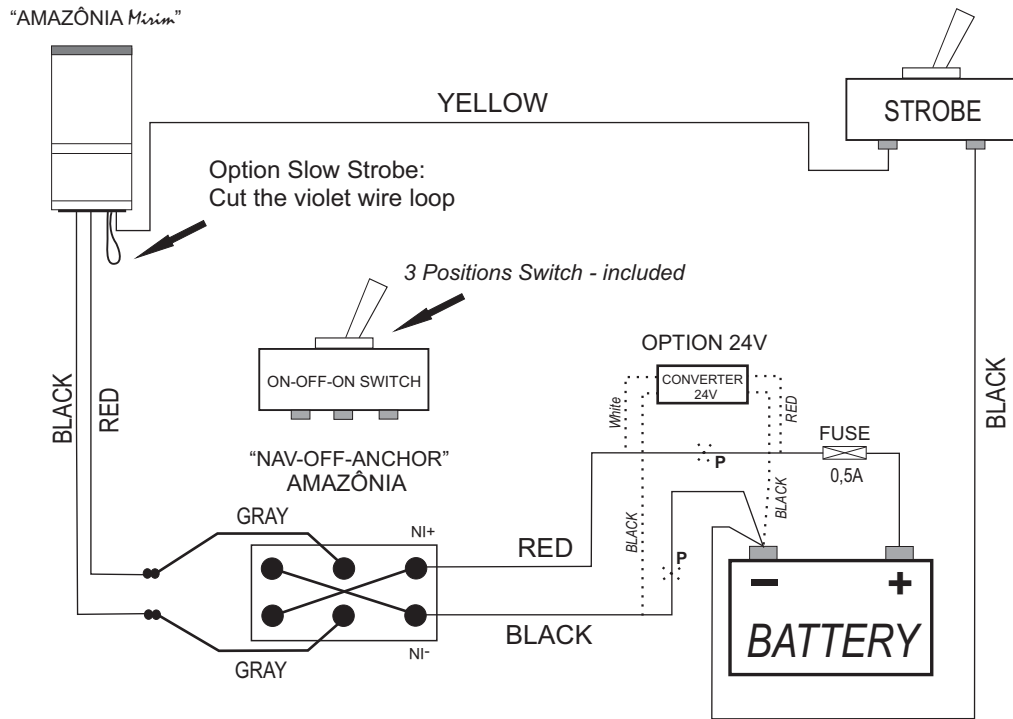

To connect the 24V converter, cut the wires at positions "P" and follow the instructions on wiring.

## "AMAZÔNIA Minim Classic"

