

FYRN



CONSOLIDATED SPEC SHEETS

P2 - 9: Stemn Seating Collection - Dining, ADU, Counter + Bar height seating

P10 - 12: Keyhole Collection - Communal tables + benches with customizable lengths

P13 - 15: Cafe Table Collection - Dining + Bar height tables with customizable heights + tabletops

Contact our team at info@fyrn.com for questions and support.



FYRN



STEMN SEATING COLLECTION



STANDARD CHAIR MARIPOSA

Series: Stemm

Materials:

- North American hardwoods with a natural oil matte finish
- Patented anodized aluminum brackets
- Optional leather upholstery

Finishes: Visit the website or contact us directly for currently available finish selections.

Weight: 12 pounds

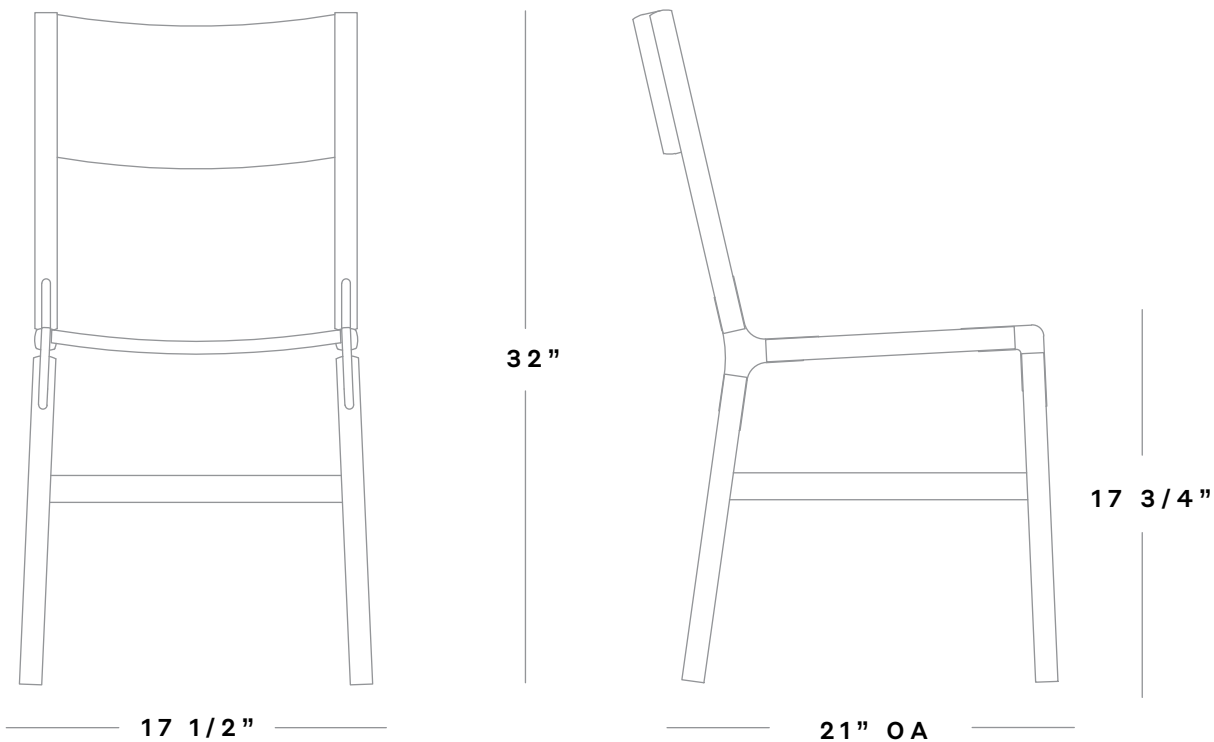

Product measurements and finish options subject to change, visit our website and contact us directly for the most current information.

BACKLESS STANDARD CHAIR SHORTY

Series: Stemm

Materials:

- North American hardwoods with a natural oil matte finish
- Patented anodized aluminum brackets
- Optional leather upholstery

Finishes: Visit the website or contact us directly for currently available finish selections.

Weight: 9 pounds

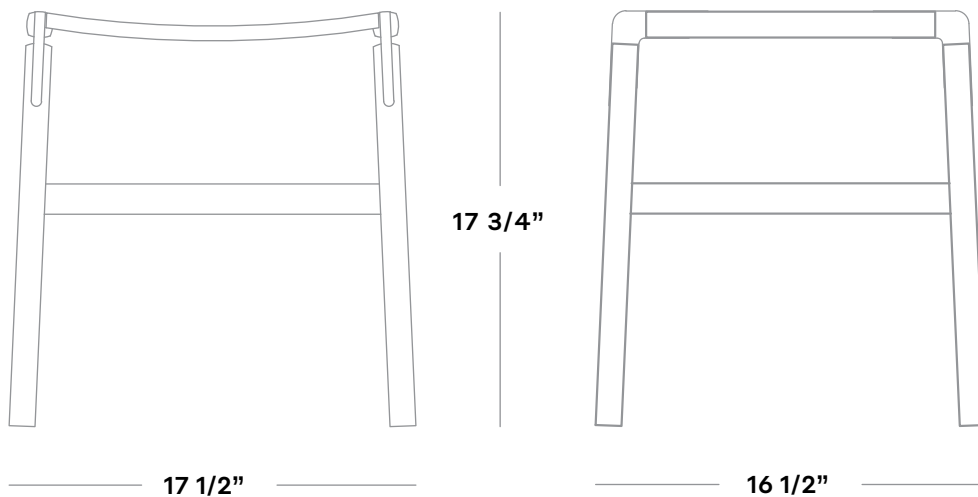

Product measurements and finish options subject to change, visit our website and contact us directly for the most current information.

BACKED ADA-HEIGHT STOOL

Series: Stemm

Materials:

- North American hardwoods with a natural oil matte finish
- Patented anodized aluminum brackets
- Optional leather upholstery

Finishes: Visit the website or contact us directly for currently available finish selections.

Weight: 13 pounds

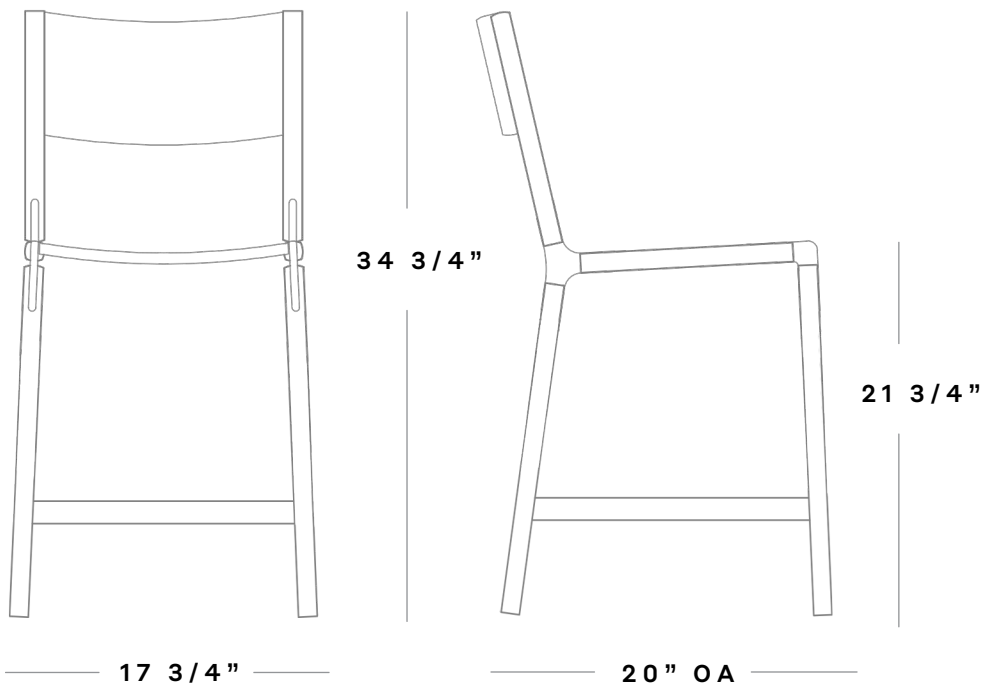

Product measurements and finish options subject to change, visit our website and contact us directly for the most current information.

BACKLESS ADA-HEIGHT STOOL

Series: Stemm

Materials:

- North American hardwoods with a natural oil matte finish
- Patented anodized aluminum brackets
- Optional leather upholstery

Finishes: Visit the website or contact us directly for currently available finish selections.

Weight: 10 pounds

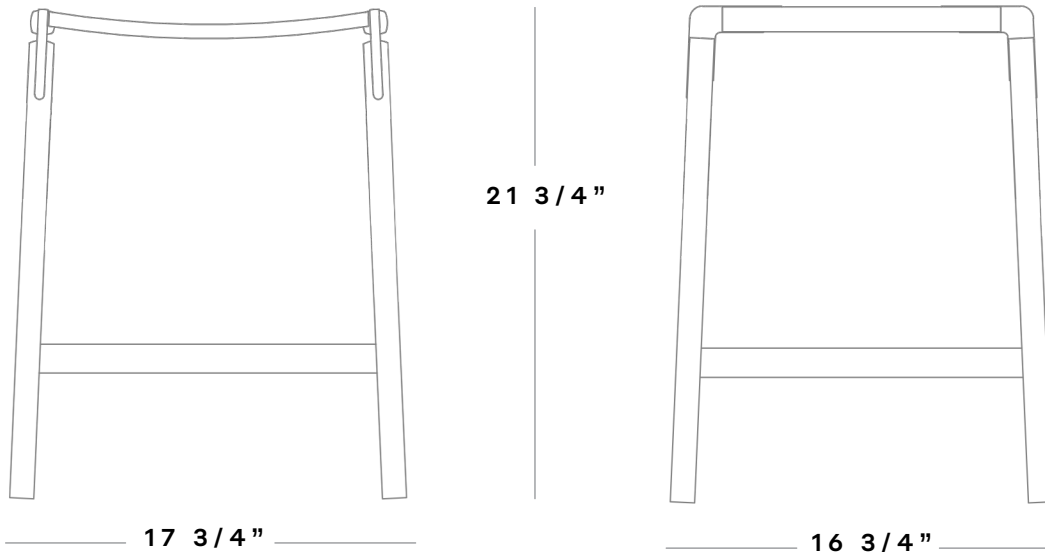

Product measurements and finish options subject to change, visit our website and contact us directly for the most current information.

COUNTER STOOL LINDEN

Series: Stemm

Materials:

- North American hardwoods with a natural oil matte finish
- Patented anodized aluminum brackets
- Optional leather upholstery

Finishes: Visit the website or contact us directly for currently available finish selections.

Weight: 13 pounds

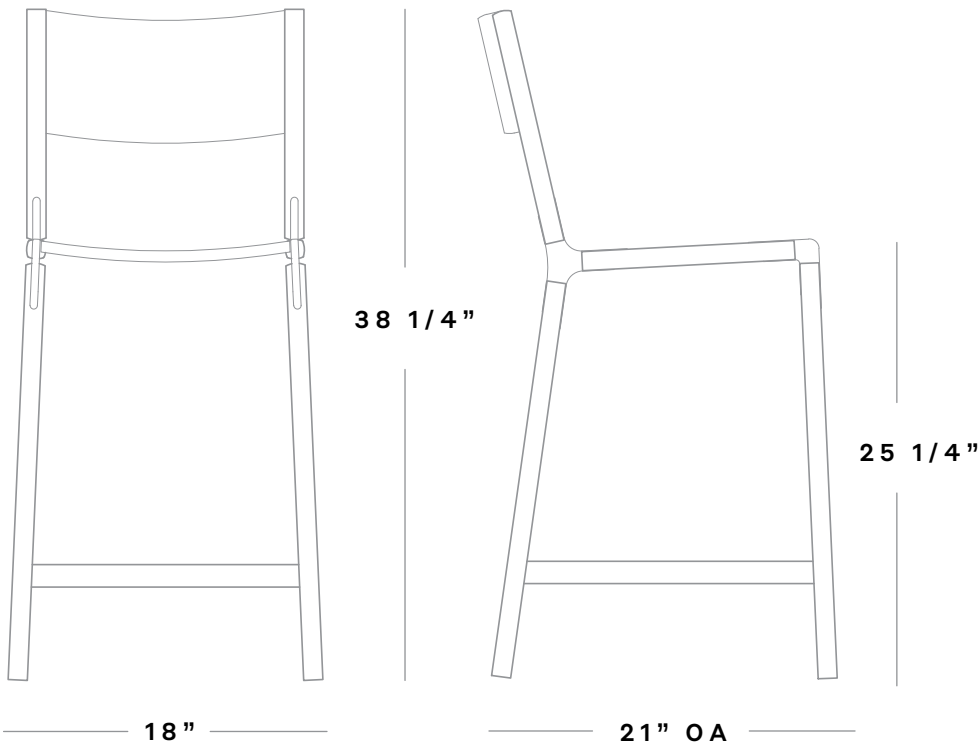

Product measurements and finish options subject to change, visit our website and contact us directly for the most current information.

BACKLESS COUNTER STOOL DE HARO

Series: Stemm

Materials:

- North American hardwoods with a natural oil matte finish
- Patented anodized aluminum brackets
- Optional leather upholstery

Finishes: Visit the website or contact us directly for currently available finish selections.

Weight: 10 pounds

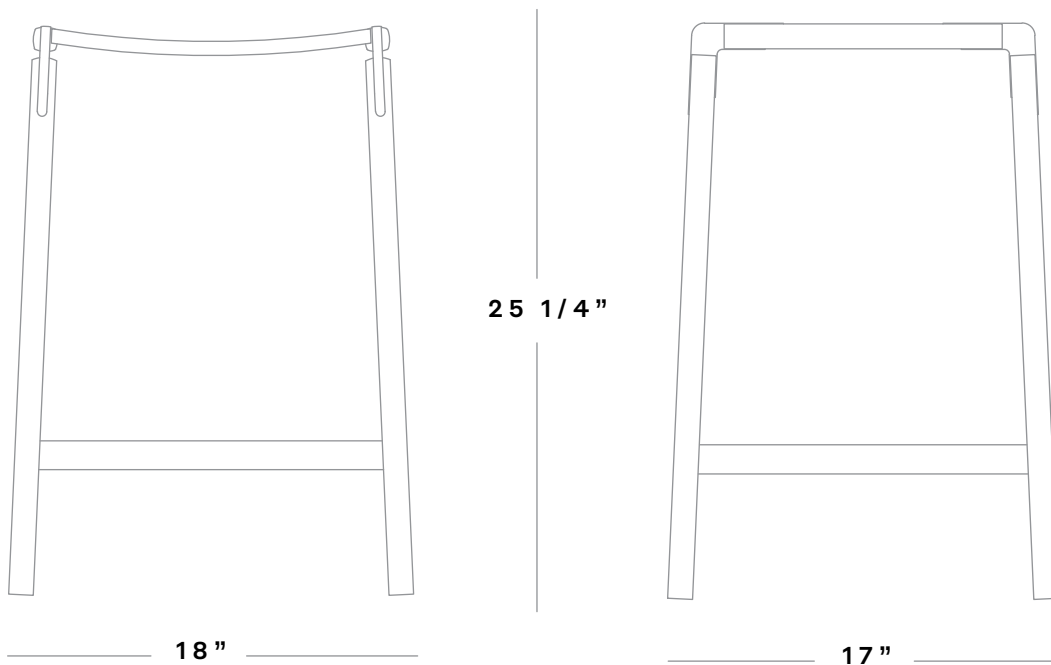

Product measurements and finish options subject to change, visit our website and contact us directly for the most current information.

BAR STOOL STANYAN

Series: Stemm

Materials:

- North American hardwoods with a natural oil matte finish
- Patented anodized aluminum brackets
- Optional leather upholstery

Finishes: Visit the website or contact us directly for currently available finish selections.

Weight: 14 pounds

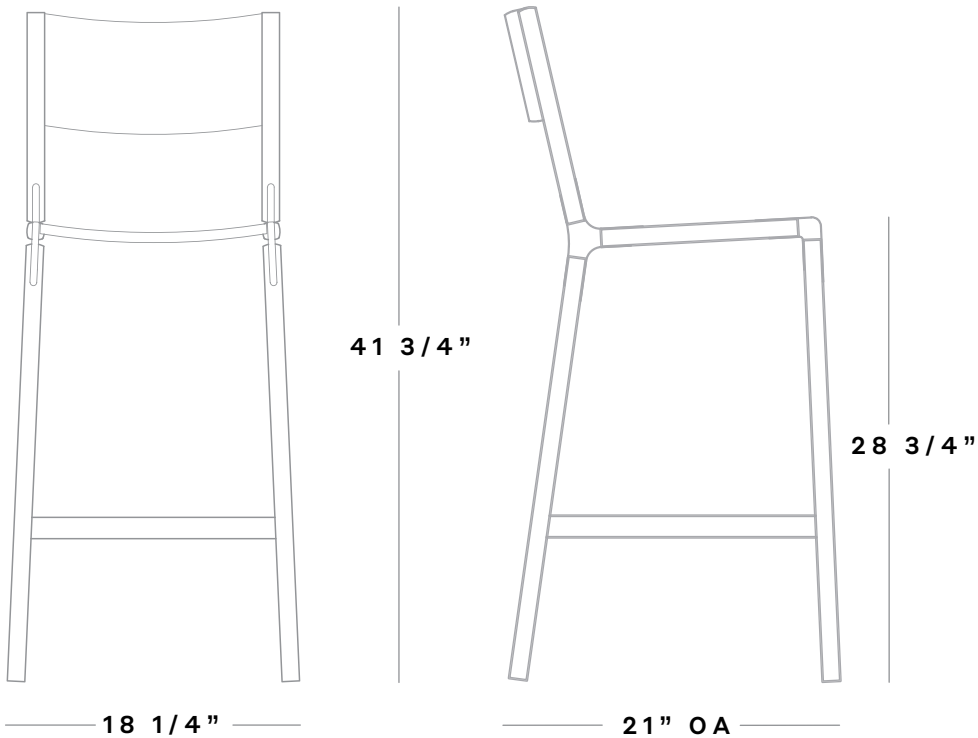

Product measurements and finish options subject to change, visit our website and contact us directly for the most current information.

FYRN



BACKLESS BAR STOOL BARTLETT

Series: Stemm

Materials:

- North American hardwoods with a natural oil matte finish
- Patented anodized aluminum brackets
- Optional leather upholstery

Finishes: Visit the website or contact us directly for currently available finish selections.

Weight: 11 pounds

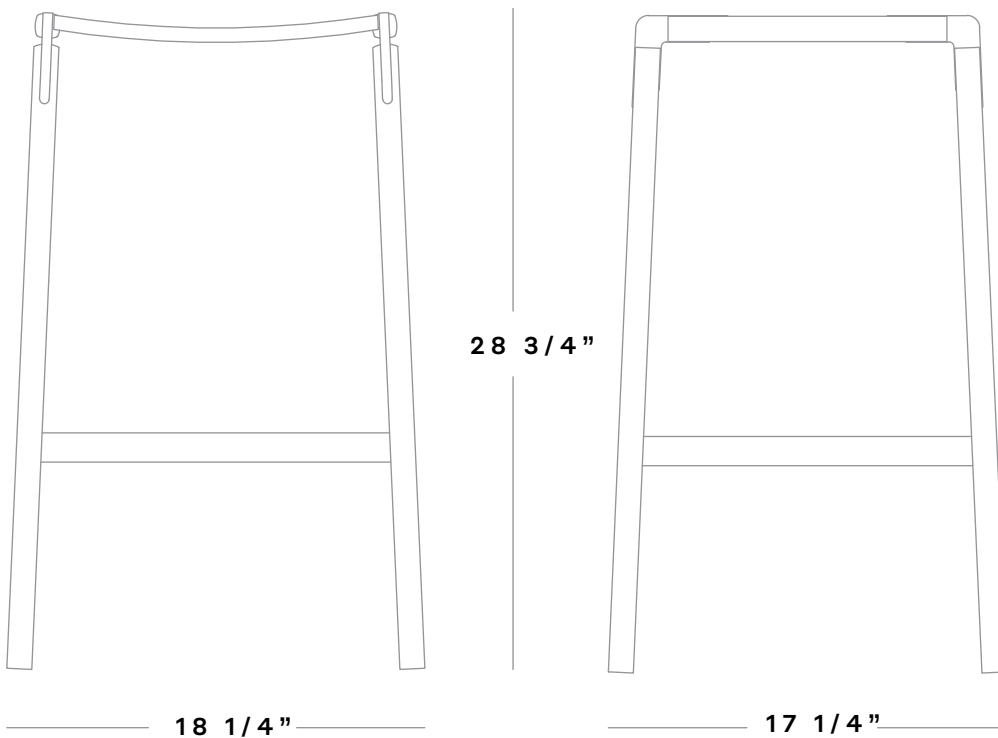

Product measurements and finish options subject to change, visit our website and contact us directly for the most current information.

FYRN F

KEYHOLE COLLECTION



KEYHOLE COLLECTION - COMMUNAL TABLES

Series: Stemm

Putting structural support on display, rather than hidden within, the collection's name derives from the proprietary brackets on view through 'keyholes' in the solid-wood tops of the communal table and bench.

A clean-lined interpretation of the classic trestle, the Keyhole Table exposes connections to elegantly float the tabletop above wooden legs.

Materials:

- North American hardwoods with a natural oil matte finish
- Patented anodized aluminum brackets

Wood Finishes: Natural Oak, Oxidized Oak or Black Walnut

Bracket Finishes: Copper Bronze or Graphite

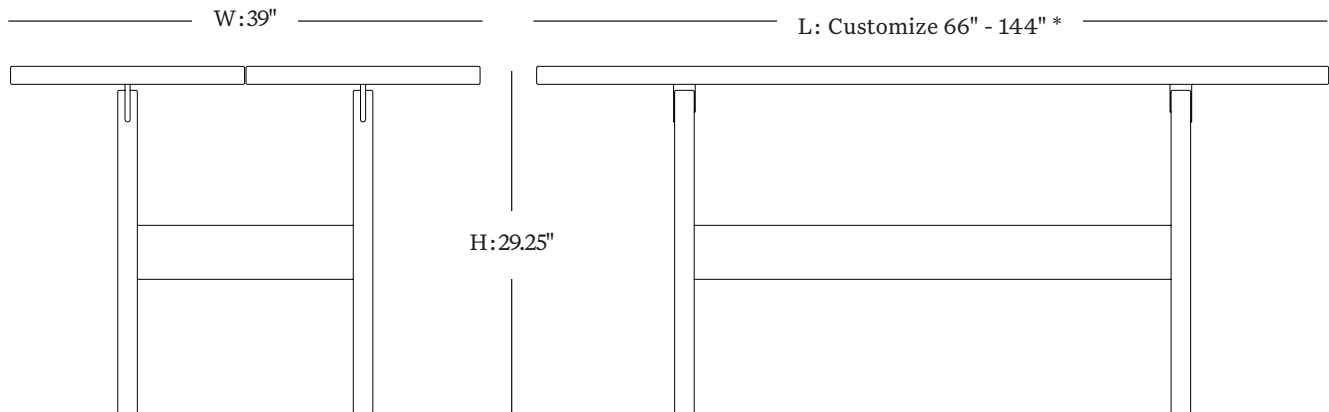

Recommended dining lengths are as follows

- 72" for 6-8 People
- 92" for 8-10 People

Recommended communal/work table lengths are as follows*

- 120" for 10-12 People
- 144" for 12-14 People

* tables of 120-144" may require engineering and aesthetic modifications to support custom lengths

KEYHOLE COLLECTION - BENCHES

Series: Stemn

Putting structural support on display, rather than hidden within, the collection's name derives from the proprietary brackets on view through 'keyholes' in the solid-wood tops of the communal table and bench.

The Keyhole Bench echoes the same trestle shape and exhibitiv engineering of the table. A perfect partner to flank either side of the table, or a piece to be integrated with the broader Fyrn seating series. Substantial in form and materiality, the bench also holds its own in an entryway, living room, hallway or bedroom.

Materials:

- North American hardwoods with a natural oil matte finish
- Patented anodized aluminum brackets

Wood Finishes: Natural Oak, Oxidized Oak or Black Walnut

Bracket Finishes: Copper Bronze or Graphite

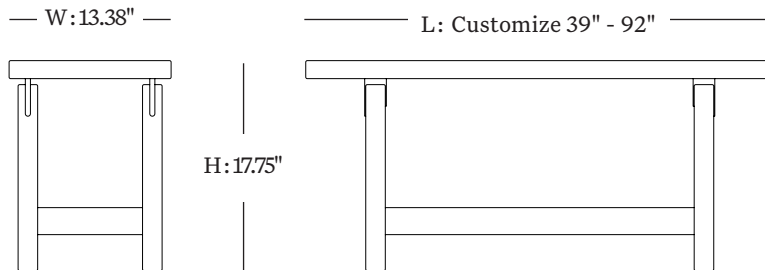

For benches paired with a table, Fyrn recommends matching the length of the table

- 39" for end of table bench
- 72" for 72" table
- 92" for 92" table

Entryway benches

- 42-48" recommended for 2 people

End of bed benches

- Fyrn recommends a bench just inside the width of the bed

FYRN



CAFE TABLE COLLECTION

FYRN.COM

INFO@FYRN.COM

(415) 805-6908

DINING-HEIGHT CAFE TABLE

AVAILABLE WITH CIRCLE, RECTANGLE, AND SQUARE TOP

Series: Cafe Table

Materials:

- North American hardwood with a natural oil matte finish
- Anodized aluminum base

Finishes: Visit the website or contact us directly for currently available finish selections.

Height & table top dimensions are customizable beyond standard sizes listed below.

Weight: Varies substantially with wood species and table top size. Inquire for specifics at time of quoting.

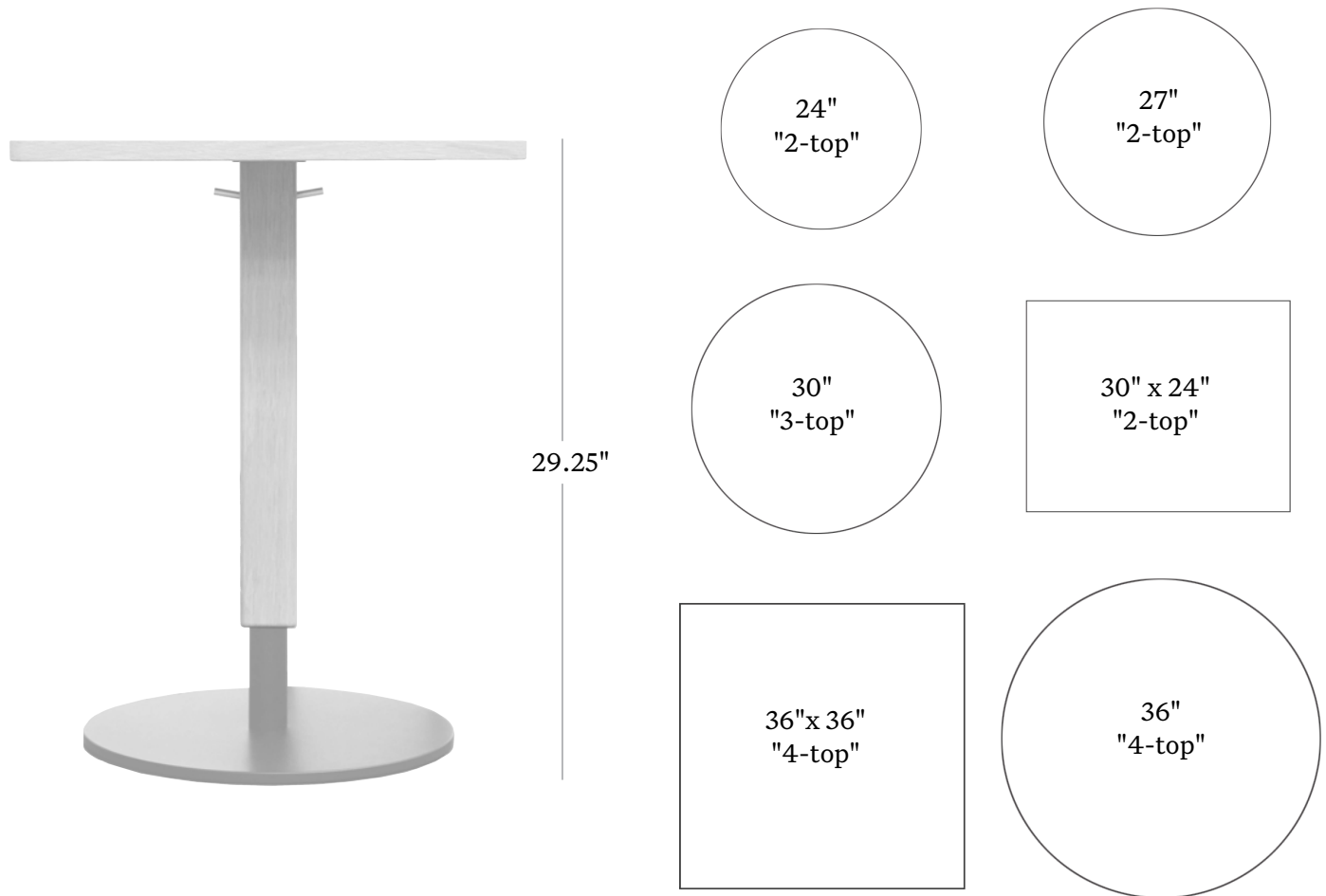

Product measurements and finish options subject to change, visit our website and contact us directly for the most current information.

BAR-HEIGHT CAFE TABLE**AVAILABLE WITH CIRCLE, RECTANGLE, AND SQUARE TOP**

Series: Cafe Table

Materials:

- North American hardwood with a natural oil matte finish
- Anodized aluminum base

Finishes: Visit the website or contact us directly for currently available finish selections.

Height & table top dimensions are customizable beyond standard sizes listed below.

Weight: Varies substantially with wood species and table top size. Inquire for specifics at time of quoting.

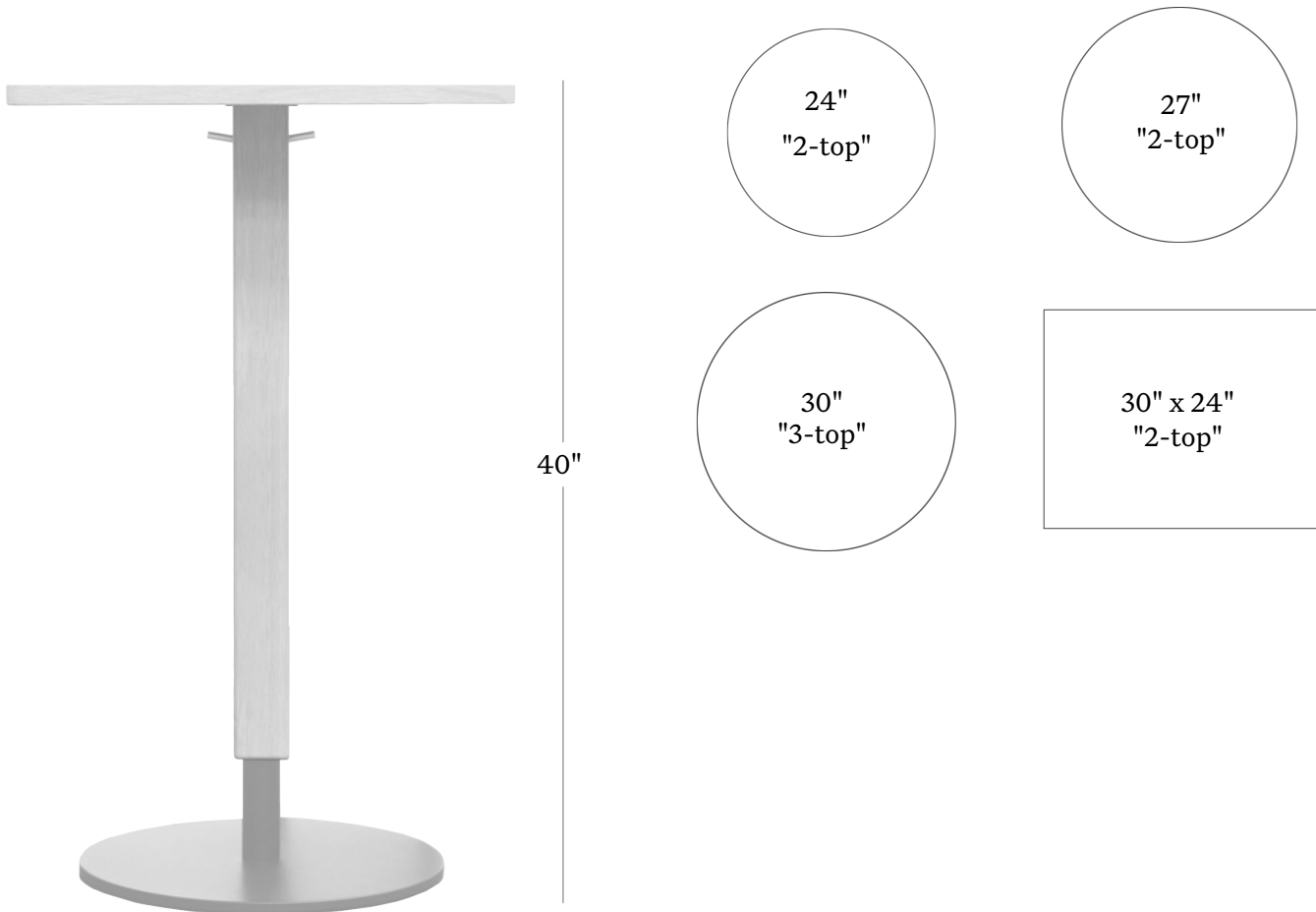

Product measurements and finish options subject to change, visit our website and contact us directly for the most current information.

A close-up photograph of a wooden chair's corner. A dark, curved metal bracket connects a thick, light-colored wooden seat to a vertical wooden leg. The background is a soft, out-of-focus gradient of light colors.

THANK YOU

Contact our customer team at info@fyrn.com for additional resources, guides and project support.