

GY-521 6-Achsen Gyroskop und Beschleunigungssensor Datenblatt

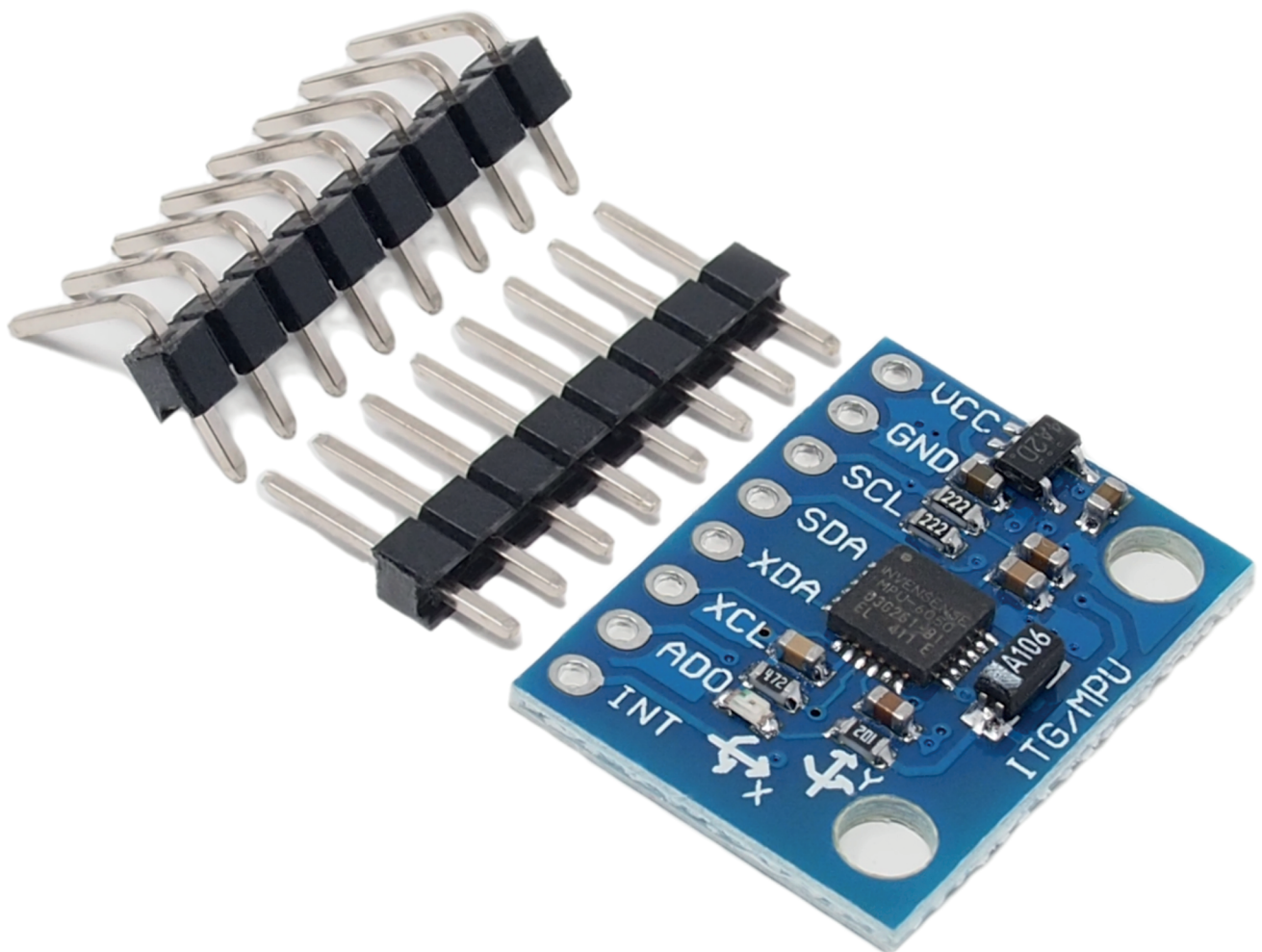

Contents:

- 1. Features**
- 2. Applications**
- 3. Electrical Characteristics**
- 4. Absolute Maximum Ratings**
- 5. Pin Assignment**
- 6. Connection Diagram**

1. Features

1.1 Gyroscope Features

The triple-axis MEMS gyroscope in the MPU-60X0 includes a wide range of features:

- Digital-output X-, Y-, and Z-Axis angular rate sensors (gyroscopes) with a user-programmable full-scale range of ± 250 , ± 500 , ± 1000 , and $\pm 2000^\circ/\text{sec}$
- External sync signal connected to the FSYNC pin supports image, video and GPS synchronization
- Integrated 16-bit ADCs enable simultaneous sampling of gyros
- Enhanced bias and sensitivity temperature stability reduces the need for user calibration
- Improved low-frequency noise performance
- Digitally-programmable low-pass filter
- Gyroscope operating current: 3.6mA
- Standby current: 5 μ A
- Factory calibrated sensitivity scale factor
- User self-test

1.2 Accelerometer Features

The triple-axis MEMS accelerometer in MPU-60X0 includes a wide range of features:

- Digital-output triple-axis accelerometer with a programmable full scale range of $\pm 2g$, $\pm 4g$, $\pm 8g$ and $\pm 16g$
- Integrated 16-bit ADCs enable simultaneous sampling of accelerometers while requiring no external multiplexer
- Accelerometer normal operating current: 500 μ A
- Low power accelerometer mode current: 10 μ A at 1.25Hz, 20 μ A at 5Hz, 60 μ A at 20Hz, 110 μ A at 40Hz
- Orientation detection and signaling
- Tap detection
- User-programmable interrupts
- High-G interrupt
- User self-test

2. Applications

- Motion-enabled game and application framework
- Location based services, points of interest
- Handset and portable gaming
- Motion-based game controllers
- Wearable sensors for health, fitness and sports
- Toys

3. Electrical Characteristics

3.1 Gyroscope Specifications

$V_{DD} = 2.375V - 3.46V$, V_{LOGIC} (MPU-6050 only) = $1.8V \pm 5\%$ or V_{DD} , $T_A = 25^\circ C$

PARAMETER	CONDITIONS	MIN	TYP	MAX	UNITS	NOTES
GYROSCOPE SENSITIVITY						
Full-Scale Range	FS_SEL=0 FS_SEL=1 FS_SEL=2 FS_SEL=3		± 250 ± 500 ± 1000 ± 2000		$^\circ/s$ $^\circ/s$ $^\circ/s$ $^\circ/s$	
Gyroscope ADC Word Length			16		bits	
Sensitivity Scale Factor	FS_SEL=0 FS_SEL=1 FS_SEL=2 FS_SEL=3		131 65.5 32.8 16.4		LSB/($^\circ/s$) LSB/($^\circ/s$) LSB/($^\circ/s$) LSB/($^\circ/s$)	
Sensitivity Scale Factor Tolerance	25 $^\circ C$	-3		+3	%	
Sensitivity Scale Factor Variation Over Temperature			± 2		%	
Nonlinearity	Best fit straight line; 25 $^\circ C$		0.2		%	
Cross-Axis Sensitivity			± 2		%	
GYROSCOPE ZERO-RATE OUTPUT (ZRO)						
Initial ZRO Tolerance	25 $^\circ C$		± 20		$^\circ/s$	
ZRO Variation Over Temperature	-40 $^\circ C$ to +85 $^\circ C$		± 20		$^\circ/s$	
Power-Supply Sensitivity (1-10Hz)	Sine wave, 100mVpp; VDD=2.5V		0.2		$^\circ/s$	
Power-Supply Sensitivity (10 - 250Hz)	Sine wave, 100mVpp; VDD=2.5V		0.2		$^\circ/s$	
Power-Supply Sensitivity (250Hz - 100kHz)	Sine wave, 100mVpp; VDD=2.5V		4		$^\circ/s$	
Linear Acceleration Sensitivity	Static		0.1		$^\circ/s/g$	
SELF-TEST RESPONSE						
Relative	Change from factory trim	-14		14	%	
GYROSCOPE NOISE PERFORMANCE	FS_SEL=0					
Total RMS Noise	DLPFCFG=2 (100Hz)		0.05		$^\circ/s$ -rms	
Low-frequency RMS noise	Bandwidth 1Hz to 10Hz		0.033		$^\circ/s$ -rms	
Rate Noise Spectral Density	At 10Hz		0.005		$^\circ/s/\sqrt{Hz}$	
GYROSCOPE MECHANICAL FREQUENCIES						
X-Axis		30	33	36	kHz	
Y-Axis		27	30	33	kHz	
Z-Axis		24	27	30	kHz	
LOW PASS FILTER RESPONSE						
	Programmable Range	5		256	Hz	
OUTPUT DATA RATE						
	Programmable	4		8,000	Hz	
GYROSCOPE START-UP TIME						
ZRO Settling (from power-on)	DLPFCFG=0 to $\pm 1\%$ of Final		30		ms	

3.2 Accelerometer Specifications

$V_{DD} = 2.375V-3.46V$, V_{LOGIC} (MPU-6050 only) = $1.8V \pm 5\%$ or V_{DD} , $T_A = 25^\circ C$

PARAMETER	CONDITIONS	MIN	TYP	MAX	UNITS	NOTES
ACCELEROMETER SENSITIVITY						
Full-Scale Range	AFS_SEL=0		±2		g	
	AFS_SEL=1		±4		g	
	AFS_SEL=2		±8		g	
	AFS_SEL=3		±16		g	
ADC Word Length	Output in two's complement format		16		bits	
Sensitivity Scale Factor	AFS_SEL=0		16,384		LSB/g	
	AFS_SEL=1		8,192		LSB/g	
	AFS_SEL=2		4,096		LSB/g	
	AFS_SEL=3		2,048		LSB/g	
Initial Calibration Tolerance			±3		%	
Sensitivity Change vs. Temperature	AFS_SEL=0, -40°C to +85°C		±0.02		%/°C	
Nonlinearity	Best Fit Straight Line		0.5		%	
Cross-Axis Sensitivity			±2		%	
ZERO-G OUTPUT						
Initial Calibration Tolerance	X and Y axes		±50		mg	1
	Z axis		±80		mg	
Zero-G Level Change vs. Temperature	X and Y axes, 0°C to +70°C		±35			
	Z axis, 0°C to +70°C		±60		mg	
SELF TEST RESPONSE						
Relative	Change from factory trim	-14		14	%	
NOISE PERFORMANCE						
Power Spectral Density	@10Hz, AFS_SEL=0 & ODR=1kHz		400		μg/√Hz	
LOW PASS FILTER RESPONSE						
	Programmable Range	5		260	Hz	
OUTPUT DATA RATE						
	Programmable Range	4		1,000	Hz	
INTELLIGENCE FUNCTION INCREMENT						
			32		mg/LSB	

1. Typical zero-g initial calibration tolerance value after MSL3 preconditioning

4. Absolute Maximum Ratings

Stress above those listed as “Absolute Maximum Ratings” may cause permanent damage to the device. These are stress ratings only and functional operation of the device at these conditions is not implied. Exposure to the absolute maximum ratings conditions for extended periods may affect device reliability.

Parameter	Rating
Supply Voltage, VDD	-0.5V to +6V
VLOGIC Input Voltage Level (MPU-6050)	-0.5V to VDD + 0.5V
REGOUT	-0.5V to 2V
Input Voltage Level (CLKIN, AUX_DA, AD0, FSYNC, INT, SCL, SDA)	-0.5V to VDD + 0.5V
CPOUT (2.5V ≤ VDD ≤ 3.6V)	-0.5V to 30V
Acceleration (Any Axis, unpowered)	10,000g for 0.2ms
Operating Temperature Range	-40°C to +105°C
Storage Temperature Range	-40°C to +125°C
Electrostatic Discharge (ESD) Protection	2kV (HBM); 200V (MM)
Latch-up	JEDEC Class II (2), 125°C ±100mA

5. Pin Assignment

Power Supply - VCC
GROUND - GND
I2C Serial Clock Line SCL
I2C Serial Data Line - SDA
Auxiliary Data pin - XDA
Auxiliary Clock pin - XCL
I2C Address select pin - ADO
Interrupt Digital Output - INT

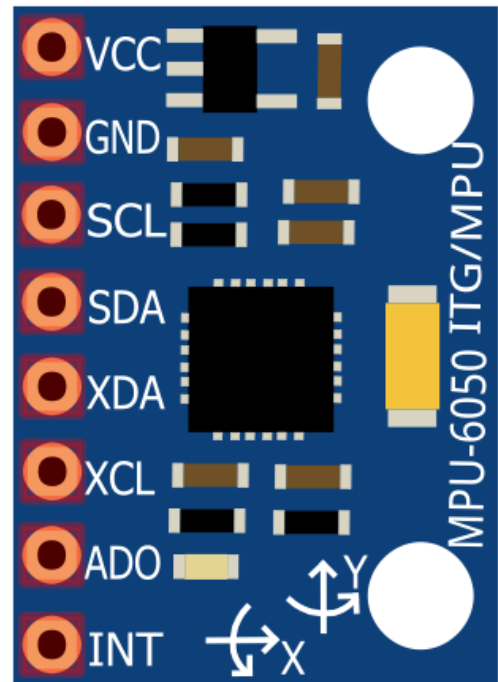

6. Connection Diagram

