

ESP-32 NodeMCU Developmentboard Datenblatt

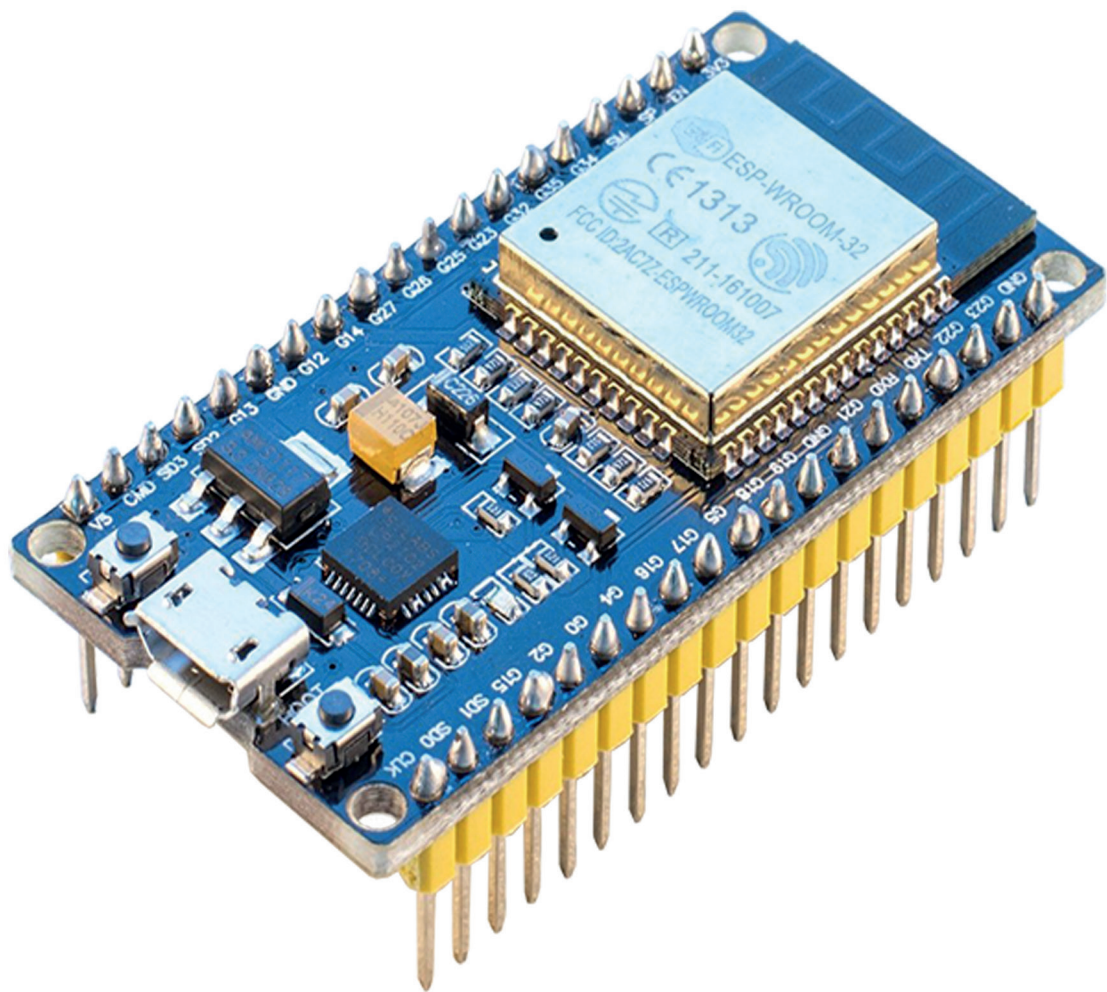

Contents:

- 1. Features**
- 2. Pinout**
- 3. Specifications**

1. Features

NodeMCU is an open source IoT platform. ESP32 is a series of low cost, low power system-on-chip (SoC) microcontrollers with integrated Wi-Fi & dual-mode Bluetooth. The ESP32 series employs a Tensilica Xtensa LX6 microprocessor in both dual-core and single-core variations, with a clock rate of up to 240 MHz. ESP32 is highly integrated with built-in antenna switches, RF balun, power amplifier, low-noise receive amplifier, filters, and power management modules.

Features:

- Able to achieve ultra-low power consumption.
- Built-in ESP-WROOM-32 chip.
- Breadboard Friendly module.
- Light Weight and small size.
- On-chip Hall and temperature sensor
- Uses wireless protocol 802.11b/g/n.
- Built-in wireless connectivity capabilities.
- Built-in PCB antenna on the ESP32-WROOM-32
- Capable of PWM, I2C, SPI, UART, 1-wire, 1 analog pin.
- Uses CP2102 USB Serial Communication interface module.
- Programmable with ESP-IDF Toolchain, LuaNode SDK supports Eclipse project (C language).

2. Pinout

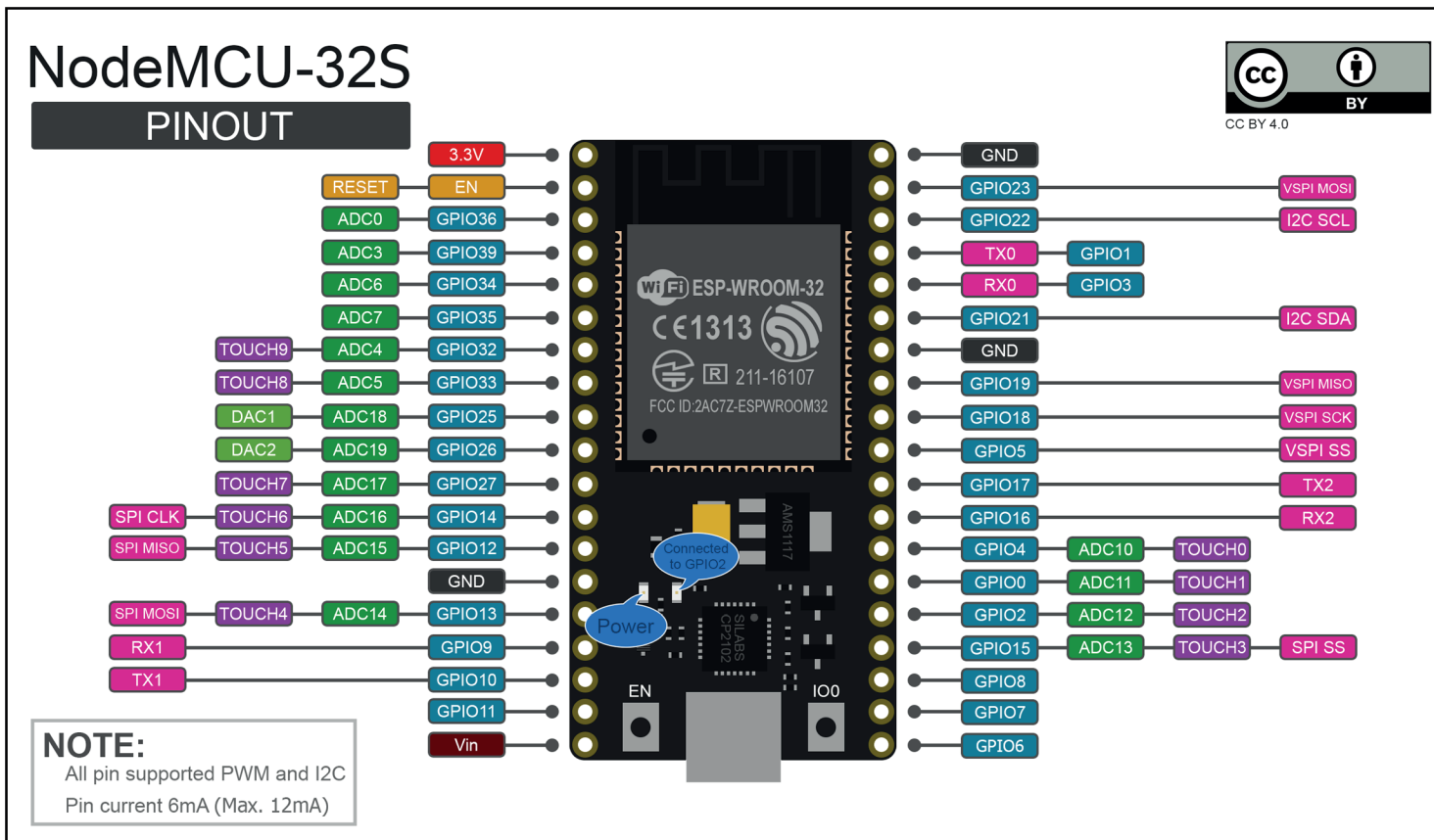

Safety Precaution:
All GPIO runs at 3.3V !!!

3. Specifications

Wireless Standard	FCC/CE/IC/TELEC/KCC/SRRC/NCC
Wireless Protocol	802.11 b/g/n/d/e/l/k/r
Frequency Range	2.4 - 2.5 GHz
Bluetooth Protocol	Bluetooth v4.2 BR/EDR and BLE specification
Bluetooth Specifications	NZIF Receiver with -98dBm sensitivity Class-1, Class-2 and Class-3 transmitter AFH, CVSD and SBC
Memory	16MB Flash, 520KB SRAM
Wireless Form	On-board PCB Antenna
IO Capability	UART, I2C, SPI, I2S, PWM, SDIO, GPIO, ADC, DAC
Electrical Characteristic	3.3 V Operated 15 mA output current per GPIO pin 80 mA average working current
Operating Temperature	-40 to +125 °C
Wireless Network Type	Station / SoftAP / SoftAP + Station / P2P
Security Type	WPA / WPA2 / WPA2-Enterprise / WPS
Encryption Type	AES / RSA / ECC / SHA
Firmware Upgrade	UART Download / OTA / Host
Network Protocol	IPv4, IPv6, SSL, TCP / UDP / FTP / HTTP / MQTT
User Configuration	AT + Order Set, Web Android / iOS, Cloud Server