

## Drehimpulsgeber Modul Datenblatt



**Contents:**

- 1. Rotary Encoder Basics**
- 2. Pin Outs**
- 3. Evaluation Circuit**

### 1. Rotary Encoder Basics

A rotary encoder has a fixed number of positions per revolution. These positions are easily felt as small "clicks" you turn the encoder.

The Keys module that I have has thirty of these positions.

**Rotary Encoder Pins** On one side of the switch there are three pins. They are normally referred to as A, B and C. In the case of the KY-040, they are oriented as shown.

Inside the encoder there are two switches. Once switch connects pin A to pin C and the other switch connects pin B to C.

In each encoder position, both switches are either opened or closed. Each click causes these switches to change states as follows:

- \* If both switches are closed, turning the encoder either clockwise or counterclockwise one position will cause both switches to open
- \* If both switches are open, turning the encoder either clockwise or counterclockwise one position will cause both switches to close.

The illustration below is representative of how the switch is constructed.

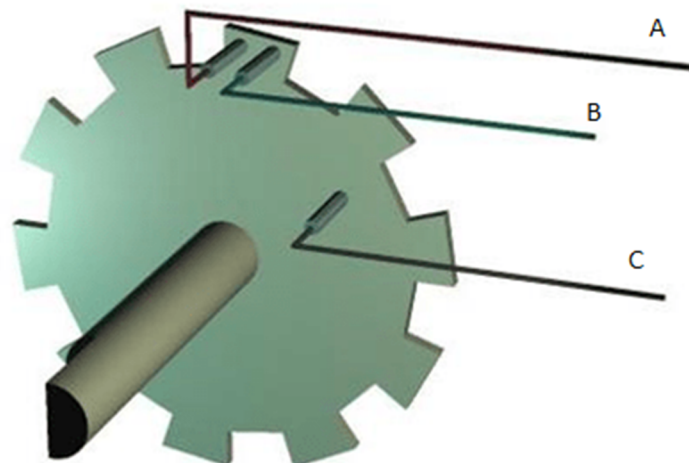

As you can see, the angular position of the A terminal and the B terminal is such that:

- \* Rotating the switch clockwise will cause the switch connecting A and C to change states first.
- \* Rotating the switch counterclockwise will cause the switch connecting B and C to change states first.

If we were to represent the opening and closing of the switches as wave forms, it would look something like this.

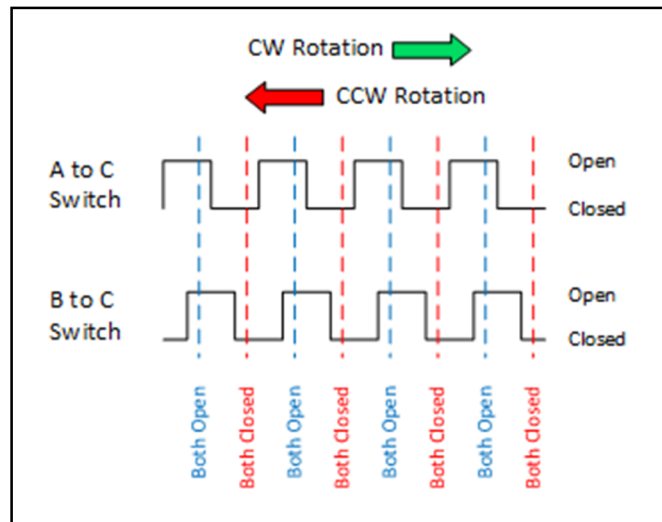

Essentially, determining which switch changed states first is how the direction of rotation is determined.

- \* If A changed states first, the switch is rotating in a clockwise direction.
- \* If B changed states first, the switch is rotating in a counter clockwise direction.

## 2. Pin Outs

The pin outs for this rotary encoder are identified in the illustration below.

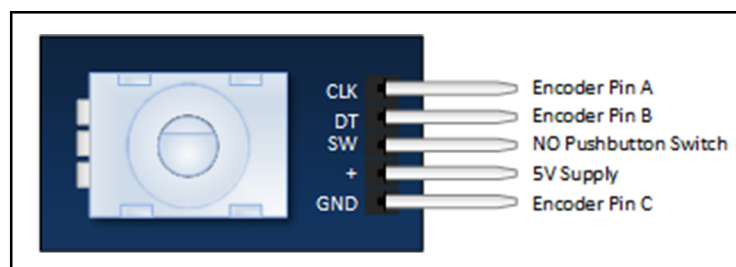

The module is designed so that a low is output when the switches are closed and a high when the switches are open.

The low is generated by placing a ground at Pin C and passing it to the CLK and DT pins when switches are closed.

The high is generated with a 5V supply input and pullup resistors, such that CLK and DT are both high when switches are open.

Not previously mentioned is the existence of a push button switch that is integral to the encoder. If you push on the shaft, a normally open switch will close. The feature is useful if you want to change switch function. For example, you may wish to have the ability to toggle between coarse and fine adjustments.

### 3. Evaluation Circuit

Successfully implementing the Rotary Encoder into any project requires a clear understanding of everything that has been discussed thus far. If you're still a little fuzzy, you may wish to throw together the evaluation circuit illustrated below:

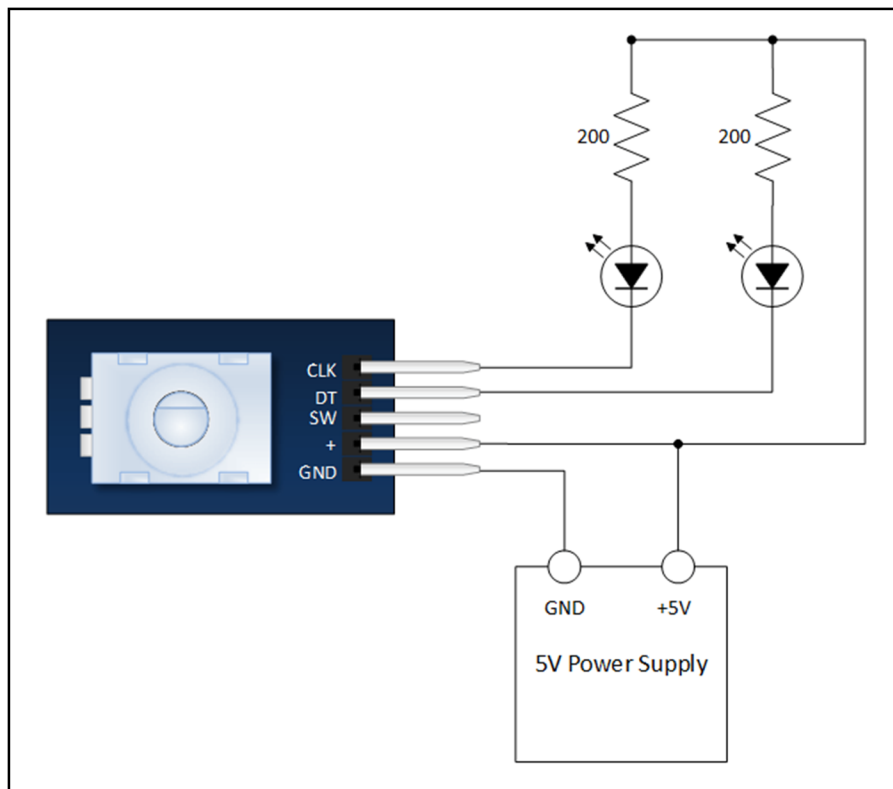

**VERY SLOWLY** rotate the encoder shaft both clockwise and counterclockwise. Notice which LEDs change state first with rotation.