

H/1048

H



**SISTEMAS DE
FECHO /**
LOCKING SYSTEMS /
SISTEMAS DE CIERRE.

ÍNDICE - SISTEMAS DE FECHO /

INDEX - LOCKING SYSTEMS /

ÍNDICE - SISTEMAS DE CIERRE.

PAG.	DESCRIÇÃO / DESCRIPTION / DESCRIPCIÓN	
1051	FECHADURAS / LOCKS / CERRADURAS	
1150	CILINDROS / CYLINDERS / CILINDROS.	
1190	DISPOSITIVOS ELECTROMECAÑICOS / ELECTRIFIED DOOR HARDWARE / DISPOSITIVOS ELECTROMECAÑICOS.	
1216	BARRAS ANTI-PÂNICO / PANIC EXIT DEVICES / DISPOSITIVOS ANTIPÁNICO.	
1238	MOLAS DE PORTA / DOOR CLOSERS / CIERRA PUERTAS.	

A silver door handle assembly is mounted on a dark wood-grain door. It includes a horizontal pull bar with a central grip and a rectangular backplate.

417

■ ■ ■
Sistemas de fecho /
Locking systems /
Sistemas de cierre.

■
Fechaduras de embutir e sobrepor /
Mortise and rim locks /
Cerraduras de embutir y sobreponer.

■
www.jnf.pt

FECHADURAS DE EMBUTIR E SOBREPOR / MORTISE AND RIM LOCKS / CERRADURAS DE EMBUTIR Y SOBREPONER /





ÍNDICE - FECHADURAS DE EMBUTIR E SOBREPOR /

MORTISE AND RIM LOCKS - INDEX/

INDICE - CERRADURAS DE EMBUTIR Y SOBREPONER /

1064	FECHADURAS DE ALTA SEGURANÇA / HIGH SECURITY LOCKS / CERRADURAS DE ALTA SEGURIDAD.	
1082	FECHADURAS DE EMBUTIR GRAU 3 / MORTISE LOCKS GRADE 3 / CERRADURAS DE EMBUTIR GRAU 3.	
1106	FECHADURAS ANTIPÂNICO / LOCK FOR ANTIPANIC DOOR / CERRADURAS PARA PUERTA Antipánico.	
1110	FECHADURAS MAGNÉTICAS MAGNETIC DOOR LOCKS / CERRADURAS MAGNETICAS.	
1118	FECHADURAS DE EMBUTIR GRAU 2 / LOCKS GRADE 2 / CERRADURAS DE GRAU 2.	
1124	FECHADURAS DE EMBUTIR GRAU 1 / LOCKS GRADE 1 / CERRADURAS DE GRAU 1.	
1129	FECHADURAS AUXILIARES E TRINCOS / AUXILIARY LOCKS AND LATCHES / CERRADURAS AUXILIARES Y PICAPORTES.	
1132	FECHADURAS PARA PERFIS ESTREITOS/ LOCKS FOR NARROW PROFILES / CERRADURAS PARA PERFILES ESTRECHOS	
1134	FECHADURAS PARA PORTAS DE CORRER / LOCKS FOR SLIDING DOORS / CERRADURAS PARA PUERTAS CORREDERAS.	
1143	ACESSÓRIOS PARA FECHADURAS / LOCKS ACCESSORIES / ACCESORIOS PARA CERRADURAS.	
1146	FECHADURAS DE ARMÁRIO / LOCKS FOR FURNITURES / CERRADURAS PARA MUEBLES.	

SERIE / REF.	RESIDENCE 	COMMERCIAL 	INSTITUTIONAL 	HOTEL 	ANTI-PANIC 	SECURITY 	FIREPROOF / ICE 	MAGNETIC 	LESS IS MORE 	NARROW PROFILES 	SLIDING DOORS 	ANTI CARD 	SILENT LATCH
SECURITY SERIES	<input type="checkbox"/>	<input type="checkbox"/>	<input type="checkbox"/>			<input type="checkbox"/>							
990 SERIES	<input type="checkbox"/>	<input type="checkbox"/>	<input type="checkbox"/>	<input type="checkbox"/>			<input type="checkbox"/>		<input type="checkbox"/>				<input type="checkbox"/>
600 SERIES	<input type="checkbox"/>	<input type="checkbox"/>	<input type="checkbox"/>	<input type="checkbox"/>	<input type="checkbox"/>		<input type="checkbox"/>		<input type="checkbox"/>			<input type="checkbox"/>	<input type="checkbox"/>
980 SERIES	<input type="checkbox"/>	<input type="checkbox"/>	<input type="checkbox"/>	<input type="checkbox"/>					<input type="checkbox"/>				<input type="checkbox"/>
970 SERIES	<input type="checkbox"/>	<input type="checkbox"/>	<input type="checkbox"/>	<input type="checkbox"/>		<input type="checkbox"/>			<input type="checkbox"/>				<input type="checkbox"/>
890 SERIES	<input type="checkbox"/>	<input type="checkbox"/>	<input type="checkbox"/>	<input type="checkbox"/>					<input type="checkbox"/>				<input type="checkbox"/>
780 SERIES	<input type="checkbox"/>	<input type="checkbox"/>	<input type="checkbox"/>		<input type="checkbox"/>								<input type="checkbox"/>
790 SERIES	<input type="checkbox"/>	<input type="checkbox"/>											<input type="checkbox"/>
800 SERIES	<input type="checkbox"/>							<input type="checkbox"/>					<input type="checkbox"/>
810 SERIES	<input type="checkbox"/>												<input type="checkbox"/>
820 SERIES	<input type="checkbox"/>												<input type="checkbox"/>
270 SERIES	<input type="checkbox"/>	<input type="checkbox"/>	<input type="checkbox"/>			<input type="checkbox"/>							
910 SERIES	<input type="checkbox"/>												<input type="checkbox"/>
700 SERIES	<input type="checkbox"/>												
IN.20.915 / 922 / 241/...	<input type="checkbox"/>										<input type="checkbox"/>		
LOCK SERVICE	<input type="checkbox"/>												
400 SERIES	<input type="checkbox"/>	<input type="checkbox"/>	<input type="checkbox"/>							<input type="checkbox"/>			

ICONOGRAFIA - CARACTERÍSTICAS TÉCNICAS / ICONOGRAPHY - TECHNICAL DATA / ICONOGRAFIA - CARACTERISTICAS TECNICAS



Fechadura para cilindro europeu /
Lock for european cylinder /
Cerradura para bombillo europeo.



Fechadura de chave normal /
Lock normal key /
Cerradura de llave normal.



Fechadura para casa de banho /
Lock for bathroom /
Cerradura para baño.



Fechadura de passagem /
Passage type lock /
Cerradura de paso.



Fechadura para uso ligeiro /
Lock for soft use /
Cerradura para uso ligero.



Fechadura para uso médio /
Lock for medium use
Cerradura para uso mediano.



Fechadura para uso intensivo /
Lock for intensive use
Cerradura para uso intensivo.



Fechadura com trinco reversível /
Lock with reversible latch /
Cerradura con picaporte reversible.



Preparada para Less is More /
Ready for Less is More /
preparado para Less is More.



Distância entre eixos /
Distance between holes
Distancia entre ejes.



Distância da testa à entrada /
Distance between strike plate and the holes /
Distancia entre frente y ejes.



Fechadura para parafusos passantes /
Lock with passing screw hole
Cerradura con agujeros para tornillos pasantes.



Quadra normal /
Normal spindle /
Nueca normal.



Quadra com mola compensadora para eliminar folga entre o puxador e a fechadura. /Spindle with internal spring to avoid any break between the handle and the lock / Nueca con muelle interior para eliminar la holgura entre la manilla e la cerradura.



Fechadura com trinco standard /
Lock with standard latch /
Cerradura con picaporte standard.



Fechadura com trinco silencioso /
Lock with silent latch /
Cerradura con picaporte silencioso.



Fechadura de rolete /
Lock with double action latch /
Cerradura vaivén.



Trinco magnético
Magnetic latch /
Picaporte magnético.



Número de chaves fornecidas /
Number of supplied keys /
Numero de llaves suministradas.



Número de ciclos testados /
Tested cycles number /
Número de ciclos Probado.



Marcação Corta fogo /
Certified Fire proof /
Certificada corta fuego.



Cantos rectos ou redondos /
Straight or rounded corners /
Cantos rectos o redondos.



Fechadura para porta anti-pânico /
Lock for antipanic door /
Cerradura para puerta antipánico.



Espessura da porta /
Thickness of the door /
Espesor de la puerta.



Fechadura para porta de correr /
Lock for sliding door /
Cerradura para puerta corredera.



Número de combinações de chave normal /
Number of combinations for normal key /
Numero de combinaciones de llave de borjas.



Fechadura de segurança /
Security lock /
Cerradura de seguridad.



Marcação CE /
CE Marking /
Marcado CE.



KIT Intumescente disponível /
Intumescent KIT available /
KIT Intumescente disponibles.



DECLARAÇÃO DE DESEMPENHO / MARCAÇÃO CE

DECLARATION OF PERFORMANCE (DOP) / CE MARKING/

DECLARACIÓN DE PRESTACIONES / MARCADO CE

Declaração de Desempenho / Marcação CE

O Regulamento (UE) n.º 305/2011 entrou em vigor em 1 de Julho de 2013, o qual estabelece condições harmonizadas para a comercialização dos produtos de construção e revoga a Directiva 89/106/CEE.

O presente regulamento obriga os fabricantes de produtos de construção a elaborar uma declaração de desempenho quando um produto de construção abrangido por uma norma harmonizada ou conforme com uma Avaliação Técnica Europeia emitida para esse produto.

Ao fazer a declaração de desempenho, o fabricante assume a responsabilidade legal pela conformidade do produto de construção com o desempenho declarado. Se a declaração de desempenho não tiver sido efectuada pelo fabricante, a marcação CE não pode ser aposta.

As fechaduras de embutir devem apresentar a marcação CE quando as mesmas têm utilização prevista em portas corta-fogo/fumo e em portas destinadas a saídas de emergência. Neste caso deve-se seguir o Sistema 1 de avaliação e verificação da regularidade do desempenho.

Norma harmonizada para fechaduras: EN12209 – Fechos e fechaduras mecânicas.

Declaration of Performance (DoP) / CE Marking

The Regulation (EU) No 305/2011 entered in to force on July 1, 2013, laying down harmonised conditions for the marketing of construction products and repealing Council Directive 89/106/EEC.

This regulation requires manufacturers of construction products to draw up a declaration of performance when a construction product covered by a harmonised standard, or complies with an European Technical Assessment issued for this product.

Making a declaration of performance, the manufacturer assumes legal responsibility for the conformity of the product with the declared performance. If the performance statement hasn't been made by the manufacturer, CE marking cannot be affixed. The locks must have the CE marking when they have and intended use in fire doors / smoke and emergency exit doors.

In this case should follow the System 1 of assessment and verification of constancy of performance.

Harmonised Standard for locks: EN12209 - Locks and latches – mechanically operated locks

Declaración de Prestaciones / Marcado CE

El Reglamento (UE) nº 305/2011 entró en vigor en 1 Julio 2013, que establece condiciones armonizadas para la comercialización de los productos de construcción y se deroga la Directiva 89/106 / CEE.

Esta regulación exige a los fabricantes de productos de construcción a elaborar una declaración de prestaciones cuando un producto de construcción cubierto por una norma armonizada, o cumple con una evaluación técnica europea emitida para este producto.

Hacer una declaración de prestaciones, el fabricante asume la responsabilidad legal de la conformidad del producto con las prestaciones declaradas. Si la declaración de prestaciones no hay sido hecha por el fabricante, el marcado CE no puede ser fijado.

Las cerraduras deben tener el marcado CE cuando tienen un uso destinado en las puertas corta-fuego/humo y puertas destinadas a salida de emergencia.

En este caso, debe seguir el Sistema 1 de evaluación y verificación de la constancia de las prestaciones.

Norma armonizada para cerraduras : EN12209 - Cerraduras, pestillos y cerraderos mecánicos

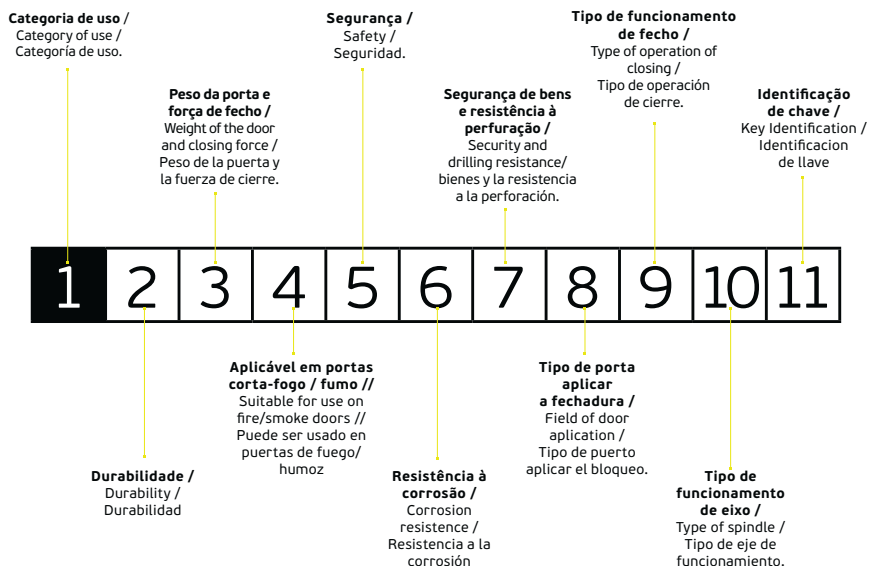

DESCRIÇÃO

1 CATEGORIA DE USO

GRAU 1: Utilização Ligeira
Fechaduras com utilização prevista por pessoas cuidadosas e com probabilidade baixa de uma utilização indevida. (Situações domésticas, escritórios e áreas onde não há acesso do público em geral)

GRAU 2: Utilização Média
Para uma utilização prevista em habitações e edifícios onde exista uma frequência média de utilização por utilizadores com algum cuidado e com os quais exista alguma probabilidade de ocorrência de acidentes ou de utilização indevida. (Situações domésticas, escritórios e áreas onde não há um acesso limitado do público em geral)

GRAU 3: Utilização Elevada
Para uma utilização prevista em edifícios onde existe uma frequência elevada de utilização por utilizadores com pouco cuidado e com uma elevada probabilidade de ocorrência de acidentes ou de má utilização. (Edifícios públicos e institucionais, como bibliotecas, hospitais e escolas)

2 DURABILIDADE

Encontram-se disponíveis doze níveis de classificação dentro deste requisito, onde as fechaduras JNF se enquadram nos cinco seguintes:

GRAU A: 50 000 ciclos de ensaio;
Sem carga no fecho;
GRAU B: 100 000 ciclos de ensaio;
Sem carga no fecho;
GRAU C: 200 000 ciclos de ensaio;
Sem carga no fecho;
GRAU H: 200 000 ciclos de ensaio;
10 N de carga no fecho;
GRAU M: 200 000 ciclos de ensaio;
25 N de carga no fecho;
GRAU X: 200 000 ciclos de ensaio;
120 N de carga no fecho.

3 PESO DA PORTA E FORÇA DE FECHO

Encontram-se identificados nove níveis de classificação, dos quais cinco são abrangidos pelas fechaduras JNF:

GRAU 1 – Portas até 100 kg,
Força máxima de 50 N para fechar.

GRAU 4 – Portas até 100 kg,
Força máxima de 25 N para fechar.
GRAU 5 – Portas até 200 kg,
Força máxima de 25 N para fechar.
GRAU 7 – Portas até 100 kg,
Força máxima de 15 N para fechar.
GRAU 8 – Portas até 200 kg,
Força máxima de 15 N para fechar.
GRAU 9 – Acima de 200 kg

4 – APLICÁVEL EM PORTAS CORTA-FOGO / FUMO

Grau 0 – Não aplicável
Grau 1 – Aplicável (De acordo com a norma EN 1634-1)

5 – SEGURANÇA

Grau : 0 – Nenhum requisito de segurança definido.
(Verificar se a fechadura é abrangida pelas normas EN179 e EN1125 – Dispositivos de emergência.)

6 – RESISTÊNCIA À CORROSÃO

Classificação de acordo com ensaio de nevoeiro salino neutro, segundo a norma EN 1670:2007
GRAU 0 – Não definido
GRAU A – 24 h – Resistência fraca à corrosão
GRAU B – 48 h – Resistência moderada à corrosão
GRAU C – 96 h – Resistência alta à corrosão
GRAU D – 240 h – Resistência elevada à corrosão
GRAU G – Resistência muito elevada à corrosão / -20° a +80°C.

7 – SEGURANÇA DE BENS E RESISTÊNCIA À PERFURAÇÃO

Grau 1 – Segurança mínima e sem resistência à perfuração
Grau 2 – Segurança baixa e sem resistência à perfuração
Grau 3 – Segurança média e sem resistência à perfuração
Grau 4 – Segurança alta e sem resistência à perfuração
Grau 5 – Segurança alta e com resistência à perfuração
Grau 6 – Segurança elevada e sem resistência à perfuração
Grau 7 – Segurança elevada e com resistência à perfuração.

8 – TIPO DE PORTA APLICAR A FECHADURA

Disponíveis 15 graus de classificação, dos quais três são aplicáveis às fechaduras JNF:
Fechadura destinada a ser aplicada:

GRAU A – Não restringida
GRAU B – Portas com dobradiças
GRAU C – Portas de correr

9 – TIPO DE FUNCIONAMENTO DE FECHO

Disponíveis nove níveis de classificação, dos quais três são aplicáveis às fechaduras JNF:
GRAU 0 – Não aplicável
GRAU A – Bloqueio de língua - Manualmente
GRAU C – Fechadura cilindro, bloqueio normal com intermédio.
GRAU D – Fechadura com chave

10 – TIPO DE FUNCIONAMENTO DE EIXO

Fechadura destinada a ser utilizada:
GRAU 0 – Sem Quadra
GRAU 1 – Puxador com mola.
GRAU 2 – Puxador sem mola.
GRAU 3 – Uso intensivo e puxador sem mola.

11 – IDENTIFICAÇÃO DE CHAVE

Número de elementos retentores / combinações.
Nota: Não aplicável a fechaduras com cilindro de perfil Europeu.

GRAU 0 – Não especificado.

Nota: Restantes graus não aplicáveis às fechaduras JNF.

DECLARAÇÃO DE DESEMPENHO / MARCAÇÃO CE

DECLARATION OF PERFORMANCE (DOP) / CE MARKING/

DECLARACIÓN DE PRESTACIONES / MARCADO CE

DESCRIPTION:

1 CATEGORY OF USE

GRADE 1: Light Use

Locks with the intended use by people with caring and a low likelihood of misuse. (Domestic situations, offices and areas where there is no general public access)

GRADE 2: Medium Use

For an intended use in homes and buildings where there is an average frequency of use by users with some care and with whom there is any likelihood of accidents or misuse. (Domestic situations, offices and areas where there is limited access to the general public)

GRADE 3 - High Use

For an intended use in buildings where there is a high frequency of use by users with little care and a high probability of occurrence of accidents or misuse. (Public and institutional buildings such as libraries, hospitals and schools)

2 DURABILITY

Are available twelve degrees of classification within this requirement, where the JNF locks fit into the following five:

Grade A: 50 000 test cycles without any load on closing;

Grade B: 100 000 test cycles without any load on closing;

Grade C: 200 000 test cycles without any load on closing;

Grade H: 200 000 test cycles, 10 N load at the close;

Grade M: 200 000 test cycles, 25 N load at the close;

Grade X: 200 000 test cycles, 120 N load at the close;

3 WEIGHT OF THE DOOR AND CLOSING FORCE

They are identified nine degrees of classification, of which five are covered by locks JNF:

GRADE 1 - doors up to 100 kg, maximum force of 50 N to close.

GRADE 4 - doors up to 100 kg, maximum force of 25 N to close.

GRADE 5 - doors up to 200 kg, maximum force of 25 N to close.

GRADE 7 - doors up to 100 kg, maximum force of 15 N to close.

GRADE 8 - Doors up to 200 kg,

maximum force of 15 N to close.

GRADE 9 - Doors above 200 kg.

4 CAN BE USED IN FIRE DOORS / SMOKE

Grade 0 - Not applicable

Grade 1 - Applicable (According to EN 1634-1)

5 SAFETY

Grade: 0 - No safety requirement set.

(Check if the lock is covered by the standards EN179 and

EN1125 - Emergency arrangements.)

6 CORROSION

Classification according to fog test neutral, according to EN 1670:2007

Grade 0 - Not defined

Grade A - 24 h - low resistance to corrosion

Grade B - 48 h - moderate resistance

to corrosion

Grade C - 96 h - high resistance to corrosion

Grade D - 240 h - High resistance

to corrosion

Grade G - Very high resistance to corrosion / -20° to +80°C

7 SAFETY OF GOODS AND PUNCTURE RESISTANCE

Grade 1 - Minimum levels of safety and without resistance to drilling

Grade 2 - Security-free and puncture resistance

Grade 3 - Medium security and without puncture resistance

Grade 4 - High security and no resistance to drilling

Grade 5 - High security and resistance to drilling

Grade 6 - Increased safety and without puncture resistance

Grade 7 - High security and resistance to drilling

8 FIELD OF DOOR APPLICATION

Available 15 degrees of classification, of which three are applicable to locks JNF:

Lock designed to be applied:

Grade A - Not restricted

Grade B - Hinged doors

Grade C - Sliding Doors

9 TYPE OF KEY OPERATION AND LOCKING

Available nine degrees of classification, of which three are applicable to locks JNF:

Grade 0 - Not applicable

Grade A - Cylinder lock - Manually

Grade C - Cylinder lock, intermediate normal latch

Grade D - Locking with key

10 - TYPE OF OPERATION SHAFT

Lock to be used:

Grade 0 - No Court

Grade 1 - Handle with spring.

Grade 2 - Handle without spring.

Grade 3 - Intensive use and handle without spring.

11 - KEY IDENTIFICATION

Number of retaining elements / combinations.

Note: Not applicable to cylinder locks with European profile.

Grade 0 - not specified.

Note: Remaining degrees do not apply to JNF locks.

DESCRIPCION:

1 CATEGORÍA DE USO

GRADO 1: Utilización ligera
Cerraduras con el uso previsto por las personas con el cuidado y una baja probabilidad de uso indebido.
(Situaciones internas, las oficinas y las zonas donde no hay acceso público en general)

GRADO 2: Utilización mediana
Para un uso determinado en los hogares y los edificios donde hay una frecuencia media de utilización por usuarios con alguna atención y con los que exista riesgo de accidentes o mal uso.
(Situaciones internas, las oficinas y las zonas donde hay un acceso limitado al público en general)

GRADO 3 - Utilización intensiva
Para un uso determinado en los edificios donde hay una alta frecuencia de utilización por usuarios con poco cuidado y una alta probabilidad de ocurrencia de accidentes o mal uso.
(Públicas y edificios institucionales, tales como bibliotecas, hospitales y escuelas)

2 DURABILIDAD

Se dispone de doce grados de clasificación dentro de esta exigencia, en el JNF cerraduras encajan en los cinco siguientes:

GRADO A: 50 000 ciclos de prueba sin ninguna carga sobre el cierre;
GRADO B: 100 000 ciclos de prueba sin ninguna carga sobre el cierre;
GRADO C: 200 000 ciclos de prueba sin ninguna carga sobre el cierre;
GRADO H: 200 000 ciclos de pruebas, carga de 10N en la clausura;
GRADO M: 200 000 ciclos de prueba, 25N de carga en la clausura;
GRADO X: 200 000 ciclos de prueba, 120N de carga en la clausura;

3 PESO DE LA PUERTA Y LA FUERZA DE CIERRE

Se identificaron nueve grados de clasificación, de los cuales cinco están cubiertos por las cerraduras JNF:

GRADO 1 - puertas de hasta 100 kg, la fuerza máxima de 50 N para cerrar.
GRADO 4 - puertas de hasta 100 kg, la fuerza máxima de 25 N para cerrar.
GRADO 5 - puertas de hasta 200 kg, la fuerza máxima de 25 N para cerrar.

GRADO 7 - puertas de hasta 100 kg, la fuerza máxima de 15 N para cerrar.
GRADO 8 - puertas de hasta 200 kg, la fuerza máxima de 15 N para cerrar.
GRADO 9 - puertas con más de 200 kg.

4 PUEDE SER USADO EN PUERTAS DE FUEGO / HUMO

GRADO 0 - No aplicable
GRADO 1 - Aplicable (según EN 1634-1)

5 SEGURIDAD

Votos: 0 - No hay requisito de seguridad establecidos. (Marque si el bloqueo está cubierto por las normas EN179 y EN1125 - Medidas de emergencia).

6 CORROSIÓN

Clasificación de acuerdo a la niebla de prueba neutral, según la norma EN 1670:2007

GRADO 0 - No definido
GRADO A - 24 h - de baja resistencia a la corrosión
GRADO B - 48 h - resistencia moderada a la corrosión
GRADO C - 96 h - elevada resistencia a la corrosión
GRADO D - 240 h - Alta resistencia a la corrosión
GRADO G - Muy alta resistencia a la corrosión / -20° hasta +80°C

7 SEGURIDAD DE LOS BIENES Y LA RESISTENCIA A LA PERFORACIÓN

GRADO 1 - Niveles mínimos de seguridad y sin resistencia a la perforación
GRADO 2 - Seguridad libres de resistencia a la punción
GRADO 3 - seguridad media y sin resistencia a la perforación
GRADO 4 - Alta seguridad y sin una resistencia a la perforación
GRADO 5 - de alta seguridad y resistencia a la perforación
GRADO 6 - Mayor seguridad y sin resistencia a la perforación
GRADO 7 - Alta seguridad y resistencia a la perforaciónpuncture resistance.

8 TIPO DE PUERTO APLICAR EL BLOQUEO

Disponible 15 grados de clasificación, de los cuales tres son aplicables a los bloqueos de KKL:
Bloquear diseñado para ser aplicado:
GRADO A - No restringido

GRADO B - puertas batientes
GRADO C - Puertas correderas

9 TIPO DE OPERACIÓN DE CIERRE

Disponible nueve grados de clasificación, de los cuales tres son aplicables a los bloqueos de JNF:

GRADO 0 - No aplicable
GRADO A - cerradura de cilindro - manualmente
GRADO C - Cerradura de cilindro, bloqueo normal con intermedio
GRADO D - Cerradura con llave

10 TIPO DE EJE DE FUNCIONAMIENTO

De bloqueo para ser utilizados:

GRADO 0 - No Corte
GRADO 1 - Actuar con muelle.
GRADO 2 - Actuar sin muelle.
GRADO 3 - Intensivo de manejar y utilizar sin muelle.

11 DETERMINACIÓN DE LOS PRINCIPALES

Número de elementos de retención combinaciones.

Nota: No se aplica a cerraduras de cilindro con perfil europeo.

GRADO 0 - No se ha especificado.

Nota: los grados restantes no se aplican a los bloqueos de JNF.

ICONOGRAFIA - CARACTERISTICAS TÉCNICAS / ICONOGRAPHY - TECHNICAL DATA / ICONOGRAFIA - CARACTERISTICAS TECNICAS

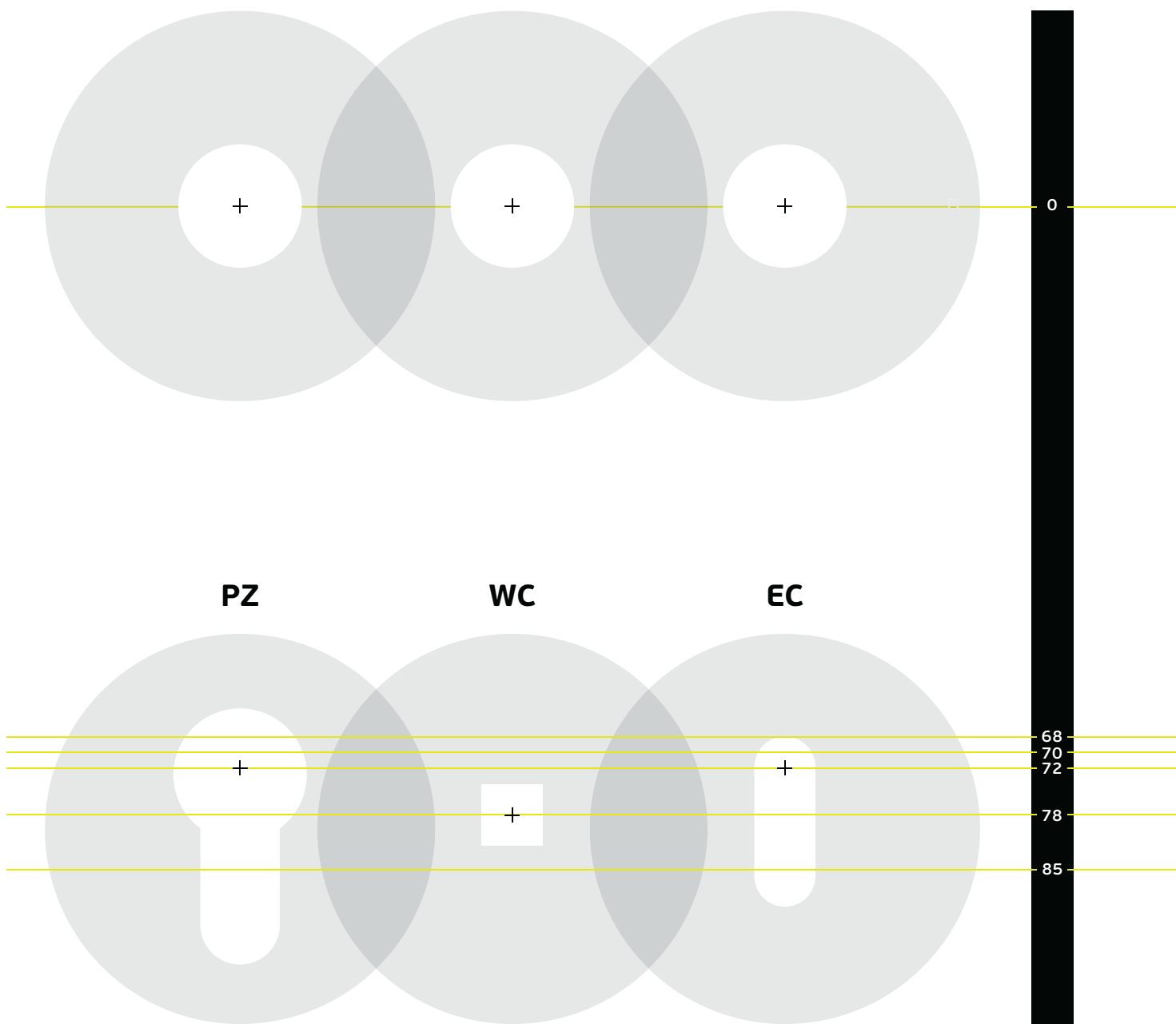

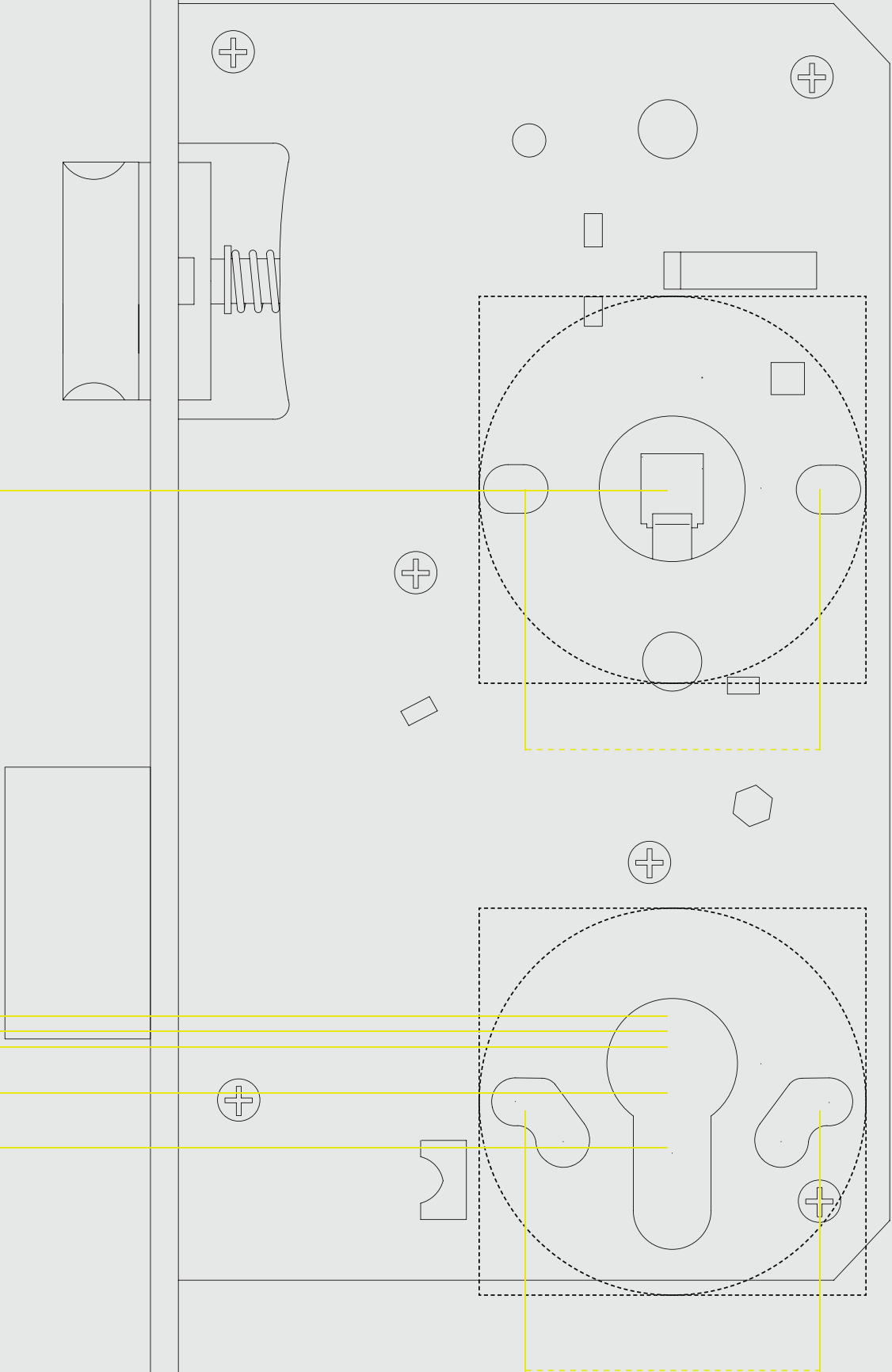

SÉRIE DE SEGURANÇA / SECURITY LOCKS SERIES / SERIE DE CERRADURAS DE SEGURIDAD

Fechadura de segurança que concilia a robustez com a suavidade do sistema de trinco magnético que permite um funcionamento silencioso e suave.

Security lock that combines robustness with the smoothness of the magnetic latch system that allows silent and smooth operation.

Cerradura de Seguridad que combina robustez con la suavidad del sistema de cierre magnético que permite un funcionamiento silencioso y suave.



Quadra em aço inox com mola interior para eliminação da folga entre o puxador e a quadra / Stainless steel handle square hole with a internal spring to avoid any gap between the Spindle and the lock / Nueca en acero inox con muelle interior para eliminar la holgura entre la manilla e la nueca

Trinco magnético metálico / Metallic magnetic latch / Picaporte magnetico metálico.

Trancas de segurança em aço inox EN 1.4301 / Security dead bolt made in stainless steel EN 1.4301 / Bullones de seguridad en acero inox EN 1.4301.

Furação para fixação do puxador / Handle fixing holes / Agujeros para tornillos pasantes.

Chapa testa 2,5mm de espessura / Strike plate with 2,5mm thickness / Cerradero con 2,5 mm. espesor.

Possível aplicação de diversos escudetes de segurança / Possible to instal different security cylinder key holes / Posible de aplicar distintos bocallaves de seguridad para bombillo.

Frente em Inox escovado apenas 20mm de largura e 10 mm de espessura / Front only in steel brushed 20mm wide and 10 mm thick / Frente en acero satin sólo con 20mm de ancho y 10 mm de espesor

Caixa fechada / Closed lock case / Caja cerrada.

Tranca superior e inferior magnética com fecho automático / Magnetic upper and down dead bolt with automatic operation / Bullones superior y inferior con cierre automatico.

IN.20.002

Fechadura de alta segurança magnética /
Magnetic high security lock /
Cerradura magnética de alta seguridad.

Material: EN 1.4301
Satinado / Satin / Satin

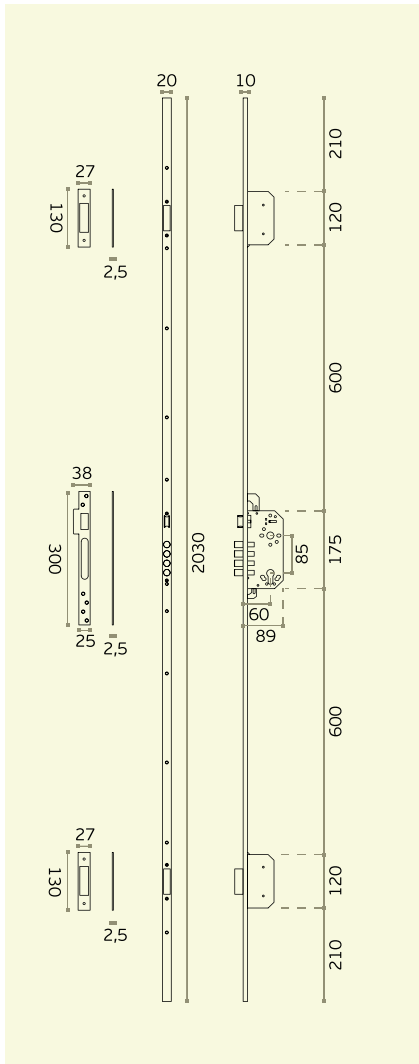

EN12209 3 H 5 0 0 C 7 B C 3 0



MAGNETIC
security lock

IN.20.003.A (80MM)

Extensão para frente de
fechadura / Extension for the
lock front / Extensión para
frente del cerradura.

IN.20.003.B (150MM)

Extensão para frente de
fechadura / Extension for the
lock front / Extensión para
frente del cerradura.



SÉRIE DE SEGURANÇA / SECURITY LOCKS SÉRIÉS / SERIE DE CERRADURAS DE SEGURIDAD

Trancas de segurança em aço inox EN 1.4301 /
 Security dead bolt made in stainless steel EN 1.4301 /
 Bullones de seguridad en acero inox EN 1.4301.

Quadra em aço inox com mola interior para eliminação da folga entre o puxador e a quadra / Stainless steel handle square hole with a internal spring to avoid any gap between the and the lock /
 Nueca en acero inox con muelle interior para eliminar la holgura entre la manilla e la nueca

Furação para fixação do puxador /
 Handle fixing holes /
 Agujeros para tornillos pasantes.

Possível aplicação de diversos escudetes de segurança /
 Possible to instal different security cylinder key holes /
 Posible de aplicar distintos bocallaves de seguridad para bombillo.

Caixa fechada /
 Closed lock case /
 Caja cerrada.

Trinco reversível em aço inox EN 1.4301 /
 Adjustable latch made in stainless steel EN 1.4301 /
 Picaporte reversible en acero inox EN 1.4301.

Trancas de segurança em aço inox EN 1.4301 /
 Security dead bolt made in stainless steel EN 1.4301 /
 Bullones de seguridad en acero inox EN 1.4301.

Chapa testa 2,5mm de espessura /
 Strike plate with 2,5mm thickness /
 Cerradero con 2,5 mm. espesor.

Frente em Inox escovado apenas 20mm de largura e 10 mm de espessura /
 Front only in steel brushed 20mm wide and 10 mm thick /
 Frente en acero satin sólo con 20mm de ancho y 10 mm de espesor

Línguas de segurança em aço inox EN 1.4301 /
 Security dead bolt made in stainless steel EN 1.4301 /
 Pestillos de seguridad en acero inox EN 1.4301.

IN.20.003

Fechadura de alta segurança /
High security lock / Cerradura de alta seguridad.

Material: EN 1.4301
Satinado / Satin / Satin

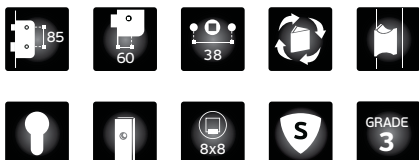
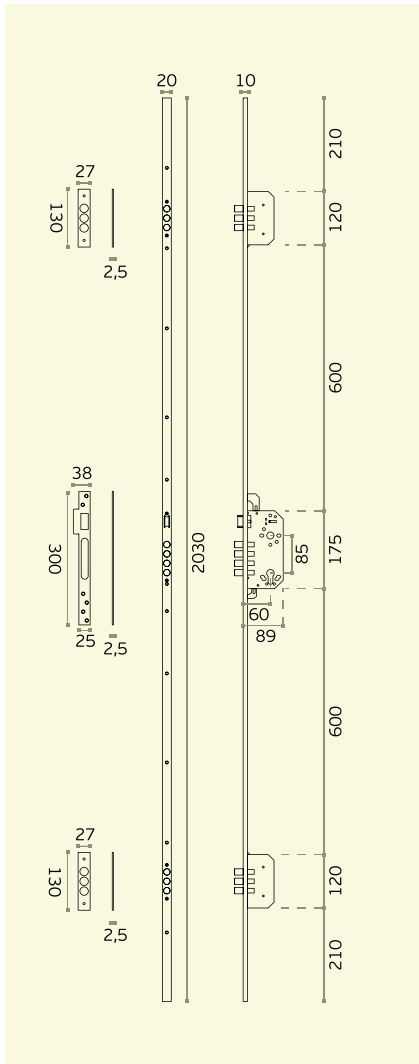

EN12209 **3 H 5 0 0 C 7 B C 3 0**



IN.20.003.A (80MM)

Extensão para frente de fechadura / Extension for the lock front / Extensión para frente del cerradura.

IN.20.003.B (150MM)

Extensão para frente de fechadura / Extension for the lock front / Extensión para frente del cerradura.



SÉRIE DE SEGURANÇA / SECURITY LOCKS SERIES / SERIE DE CERRADURAS DE SEGURIDAD

A Série de segurança da JNF foi criada para ser utilizada em portas que estão sujeitas a uma utilização elevada.

JNF's Security locks series was created to be applied in doors that have high use.

La serie de cerraduras de seguridad JNF fue creada para ser aplicada en puertas que se utilizan de un modo elevado.



GRADE
3

500 Mil
cycles

Quadra em aço inox com mola interior para eliminação da folga entre o puxador e a quadra / Stainless steel handle square hole with a internal spring to avoid any gap between the Spindle and the lock / Nueca en acero inox con muelle interior para eliminar la holgura entre la manilla e la nueca

Furação para fixação do puxador / Handle fixing holes /
Agujeros para tornillos pasantes.

Possível aplicação de diversos escudetes de segurança / Possible to instal different security cylinder key holes /
Posible de aplicar distintos bocallaves de seguridad para bombillo.

Caixa fechada / Closed lock case /
Caja cerrada.



Trinco reversível em aço inox EN 1.4301 / Adjustable latch made in stainless steel EN 1.4301 /
Picaporte reversible en acero inox EN 1.4301.

Trancas de segurança em aço inox EN 1.4301 / Security dead bolt made in stainless steel EN 1.4301 /
Bullones de seguridad en acero inox EN 1.4301.

Chapa testa 2,5mm de espessura / Strike plate with 2,5mm thickness /
Cerradero con 2,5 mm. espesor.

Frente em Inox escovado apenas 23mm de largura e 3 mm de espessura / Front only in steel brushed 23mm wide and 3 mm thick /
Frente en acero satin sólo con 23mm de ancho y 3 mm de espesor

IN.20.004

Fechadura de alta segurança /
High security lock /
Cerradura de alta seguridad

Material: EN 1.4301
Satinado / Satin / Satin

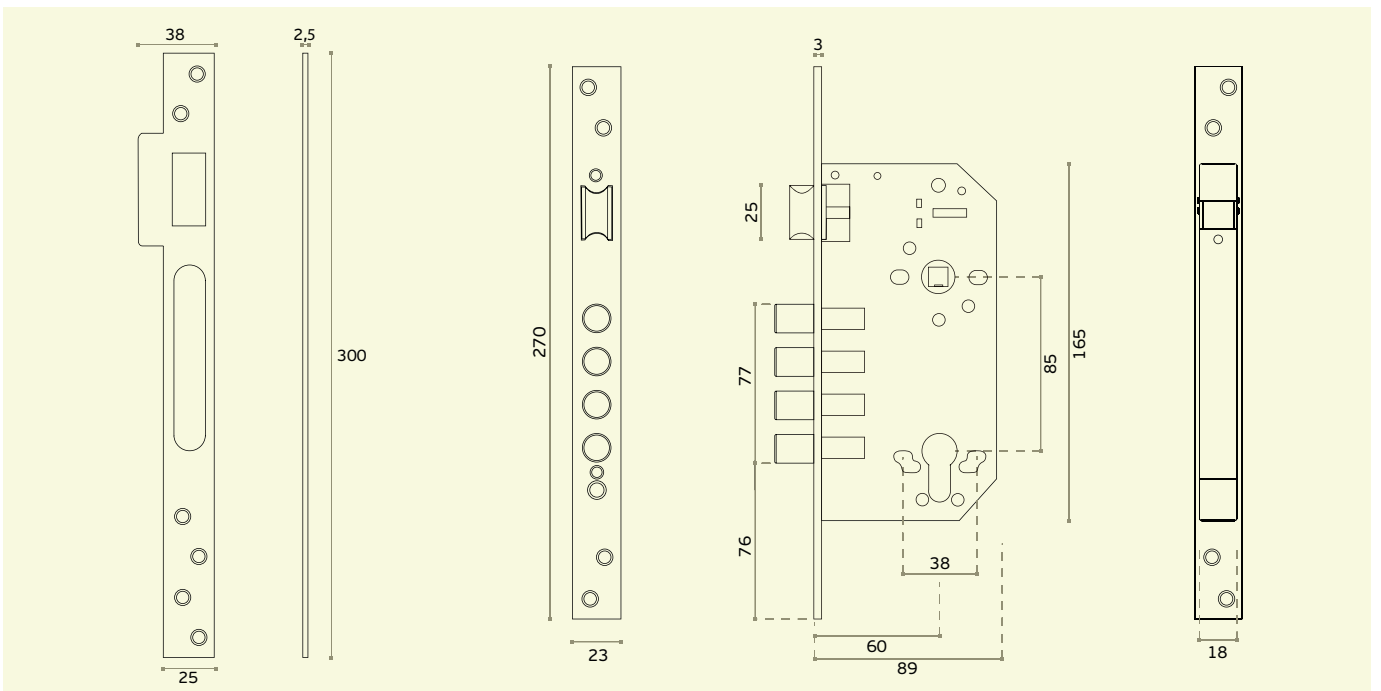
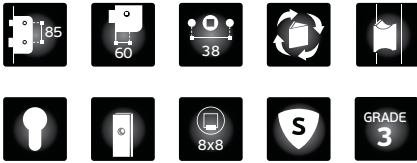
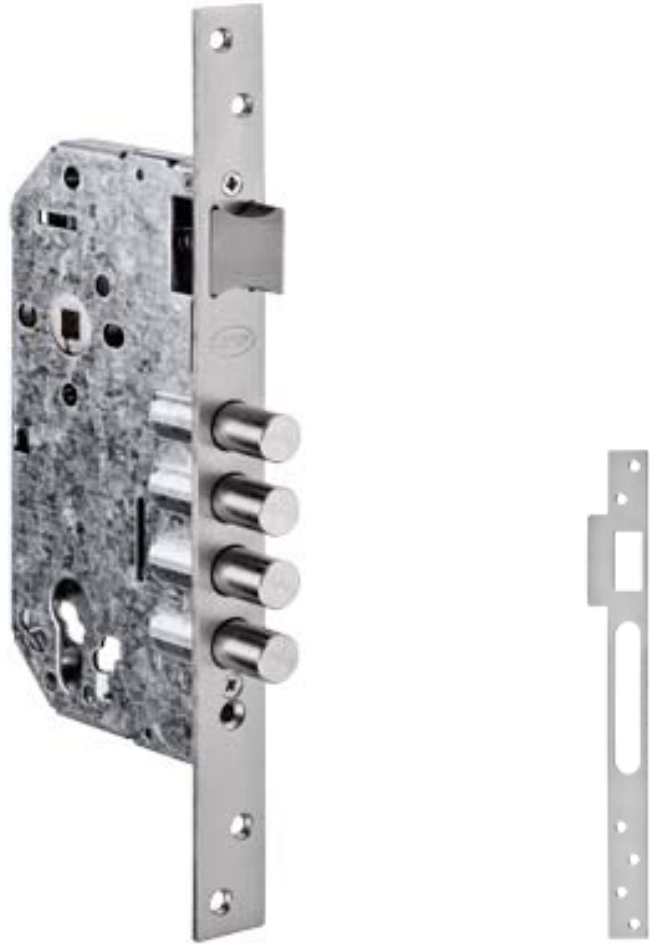

SÉRIE DE SEGURANÇA DE SOBREPOR / RIM SECURITY LOCKS SERIES / SERIE DE CERRADURAS DE SEGURIDAD DE SOBREPONER

Trancas de segurança em aço inox EN 1.4301 /
 Security dead bolt made in stainless steel EN 1.4301 /
 Bullones de seguridad en acero inox EN 1.4301.

Função Anti-pânico /
 Anti panic function /
 Función Antipánico

Quadra em aço inox com mola interior para eliminação da folga entre o puxador e a quadra / Stainless steel handle square hole with a internal spring to avoid any gap between the Spindle and the lock /
 Nueca en acero inox con muelle interior para eliminar la holgura entre la manilla e la nueca

Furação para fixação do puxador /
 Handle fixing holes /
 Agujeros para tornillos pasantes.

Furação para fixação do escudete de segurança /
 Security rose fixing holes /
 Agujeros para fijación de escudo de seguridad.

Trinco silencioso em aço inox EN 1.4301 /
 Silent latch made in stainless steel EN 1.4301 /
 Picaporte silencioso en acero inox EN 1.4301.

Trancas de segurança com rotação anti-serra em aço temperado e revestidas em aço inox EN 1.4301 /
 Security dead bolt with anti-saw rotation, made in tempered steel and covered with stainless steel EN 1.4301 /
 Bullones de seguridad con rotación anti-sierra, en acero templado e cubiertas en acero inox EN 1.4301.

Bloqueio suplementar - anula a função anti-pânico /
 Additional lock - cancels the anti-panic function /
 Cierre adicional - anula la función antipánico.

Caixa em Inox escovado /
 Box in brushed steel /
 Caja en acero Inox satin.

Línguas de segurança em aço inox EN 1.4301 /
 Security dead bolt made in stainless steel EN 1.4301 /
 Pestillos de seguridad en acero inox EN 1.4301.



NEW

IN.20.021.D - Direita / Right / Derecha
IN.20.021.E - Esquerda / Left / Izquierda

Fechadura de alta segurança de sobrepor /
Rim High security lock /
Cerradura de alta seguridad de sobreponer.

Material: EN 1.4301
Satinado / Satin / Satin

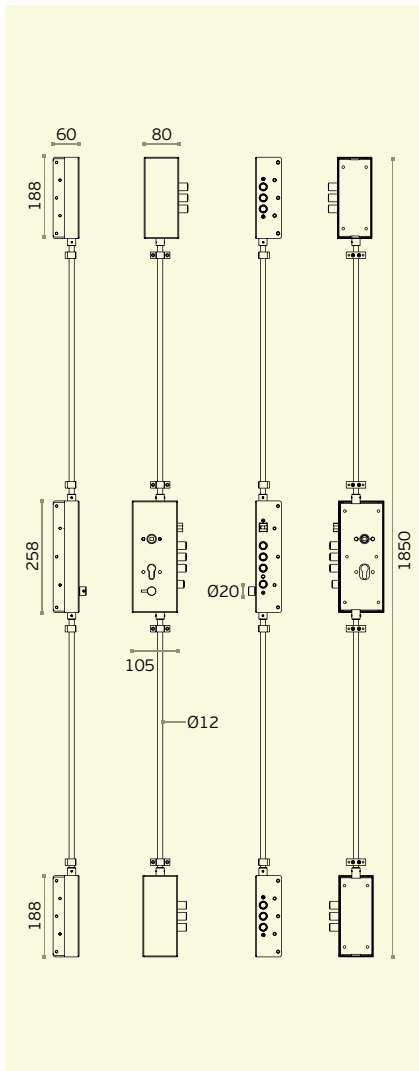

Aconselhamos cilindro com 90mm (60+30) para portas de 30mm de espessura ou 100mm (70+30) para portas de 40mm, juntamente com o escudo de segurança Ref. IN.04.29S para um bom funcionamento /

Recommended to use a cylinder size 90mm (60+30) for 30mm doors or 100mm (70+30) for 40mm doors, combined with the security rose Ref. IN.04.29S for a perfect performance /

Recomendamos la utilización de un bombillo con 90mm (60+30) para puertas de 30mm de espesor o 100mm (70+30) para puertas de 40mm, combinado con el escudo protector Ref. IN.04.29S para un funcionamiento correcto.

Fechadura que se encontra no interior /
Lock that can be found inside /
Cerradura que se encontra en el interior.



Na imagem fechadura direita /
On the image right handed lock /
En la imagen cerradura derecha

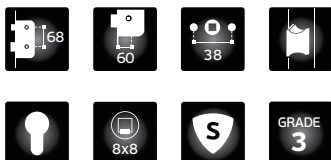

SÉRIE DE SEGURANÇA DE SOBREPOR /

RIM SECURITY LOCKS SERIES /

SERIE DE CERRADURAS DE SEGURIDAD DE SOBREPONER

A Série de segurança da JNF foi criada para ser utilizada em portas que estão sujeitas a uma utilização elevada.

JNF's Security Series was created to be applied in doors that have high use.

La serie de seguridad JNF fue creada para ser aplicada en puertas que se utilizan de un modo elevado.



GRADE
3

500 Mil
cycles

Trinco silencioso em aço inox EN 1.4301 /
Silent latch made in stainless steel EN 1.4301 /
Picaporte silencioso en acero inox EN 1.4301.

Trancas de segurança com rotação anti-serra em aço temperado e revestidas em aço inox EN 1.4301 /
Security dead bolt with anti-saw rotation, made in tempered steel and covered with stainless steel EN 1.4301 /
Bullones de seguridad con rotación anti-sierra, en acero templado e cubiertas en acero inox EN 1.4301.

Bloqueio suplementar - anula a função anti-pânico /
Additional lock - cancels the anti-panic function /
Cierre adicional - anula la función antipánico.

Caixa fechada aço inox EN.1.4301 /
Closed lock case made in stainless steel EN.1.4301 /
Caja cerrada en acero inoxidable EN.1.4301

Possível trancar a fechadura com o puxador / It's possible to lock the door with the lever handle /
Posibilidad de cerrar la cerradura con la manilla.

Possível aplicar qualquer modelo de puxador JNF / Applicable with any JNF lever handle model /
Posibilidad de aplicar cualquier tipo de manilla JNF.

Cilindro Europeu /
European cylinder / Bombillo Europeo.



NEW

IN.20.012.D - Direita / Right / Derecha
IN.20.012.E - Esquerda / Left / Izquierda

Fechadura de alta segurança de sobrepor /
Rim High security lock /
Cerradura de alta seguridad de sobreponer.

Material: EN 1.4301
Satinado / Satin / Satin

Aconselhamos cilindro com 90mm (60+30)
para portas de 30mm de espessura ou 100mm
(70+30) para portas de 40mm, juntamente com o
escudo de segurança Ref. IN.04.29S para um bom
funcionamento /

Recommended to use a cylinder size 90mm (60+30)
for 30mm doors or 100mm (70+30) for 40mm doors,
combined with the security rose Ref. IN.04.29S for a
perfect performance /

Recomendamos la utilización de un bombillo con 90mm
(60+30) para puertas de 30mm de espesor o 100mm
(70+30) para puertas de 40mm, combinado con el escudo
protector Ref. IN.04.29S para un funcionamiento correcto.

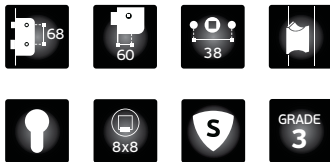

Na imagem fechadura direita /
In the image right handed lock /
En la imagen cerradura derecha

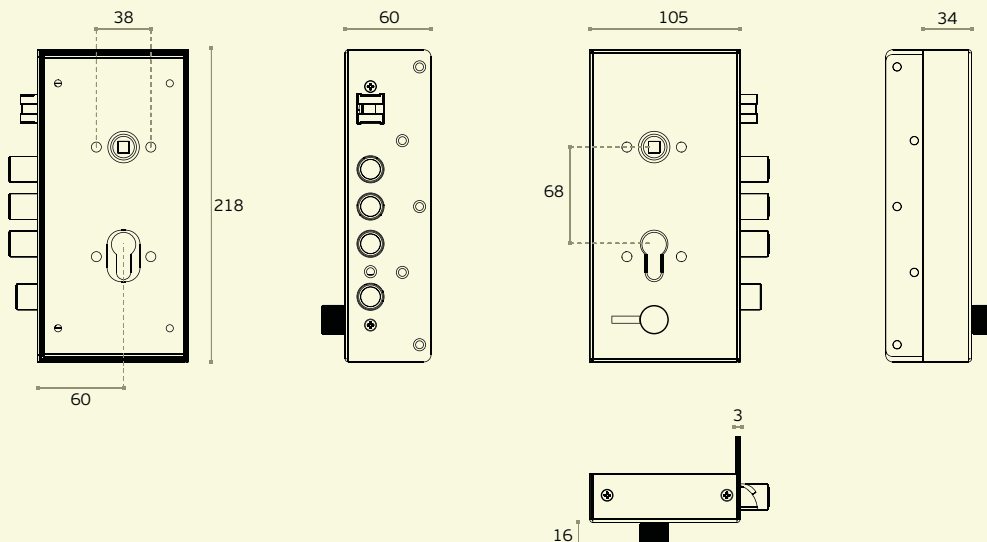

SÉRIE DE SEGURANÇA / SECURITY LOCKS SERIES / SERIE DE CERRADURAS DE SEGURIDAD

NEW

IN.20.015.D - Direita / Right / Derecha
IN.20.015.E - Esquerda / Left / Izquierda
Chapa testa para aplicar com IN.20.012 /
 Strike plate to instal with IN.20.012 /
 Cerradero para instalar con IN.20.012.
Material: EN 1.4301
 Satinado / Satin / Satin



Na imagem testa direita /
 In the image right hand strike /
 En la imagen cerradero derecho

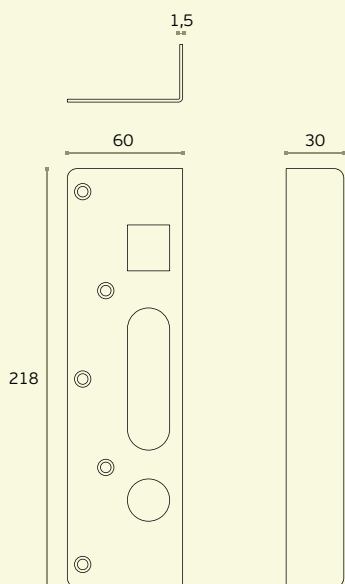

NEW

IN.20.016.D - Direita / Right / Derecha
IN.20.016.E - Esquerda / Left / Izquierda
Chapa testa reforçada para aplicar com IN.20.012 /
 Reinforced Strike plate to instal with IN.20.012 /
 Cerradero reforzado para instalar con IN.20.012.
Material: EN 1.4301
 Satinado / Satin / Satin



Na imagem testa direita /
 In the image right hand strike /
 En la imagen cerradero derecho

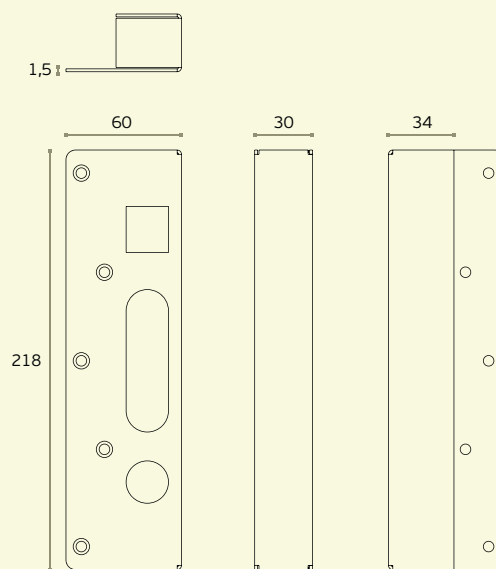

NEW

IN.20.022.D - Direita / Right / Derecha
IN.20.022.E - Esquerda / Left / Izquierda
Chapa testa para aplicar com IN.20.021 /
 Strike plate to instal with IN.20.021 /
 Cerradero para instalar con IN.20.021.
Material: EN 1.4301
 Satinado / Satin / Satin

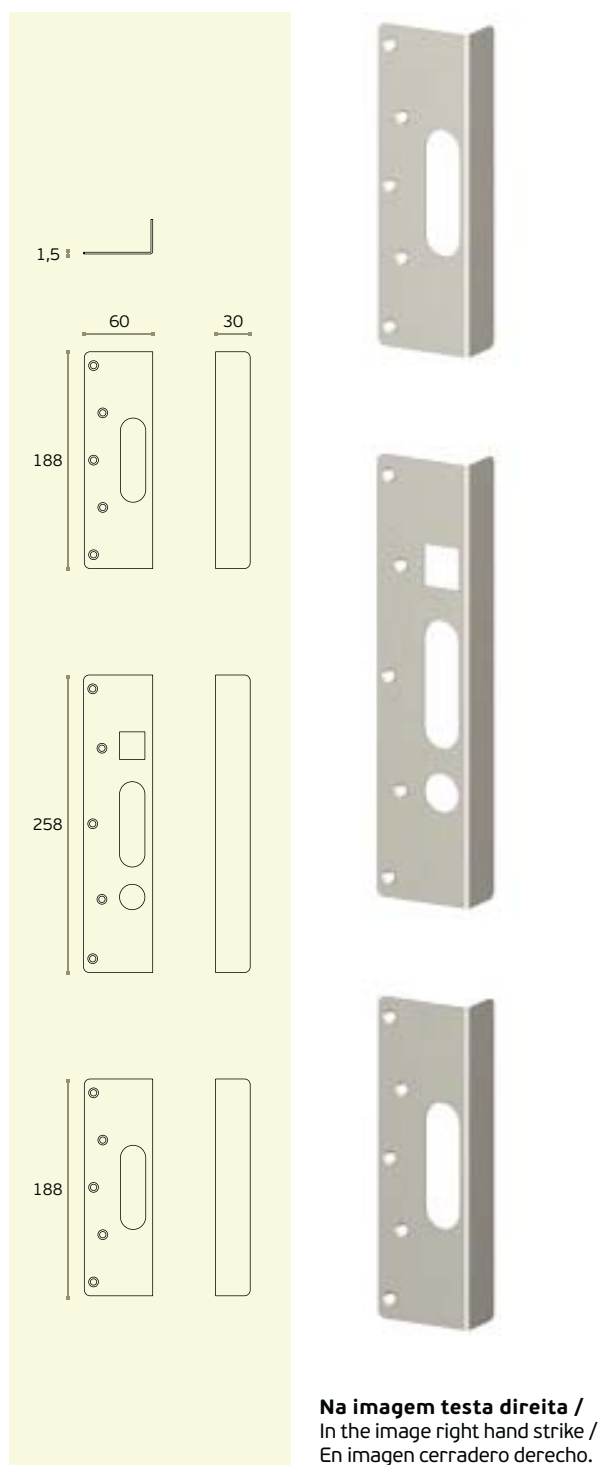

NEW

IN.20.023.D - Direita / Right / Derecha
IN.20.023.E - Esquerda / Left / Izquierda
Chapa testa reforçada para aplicar com IN.20.021 /
 Reinforced Strike plate to instal with IN.20.021 /
 Cerradero reforzado para instalar con IN.20.021.
Material: EN 1.4301
 Satinado / Satin / Satin

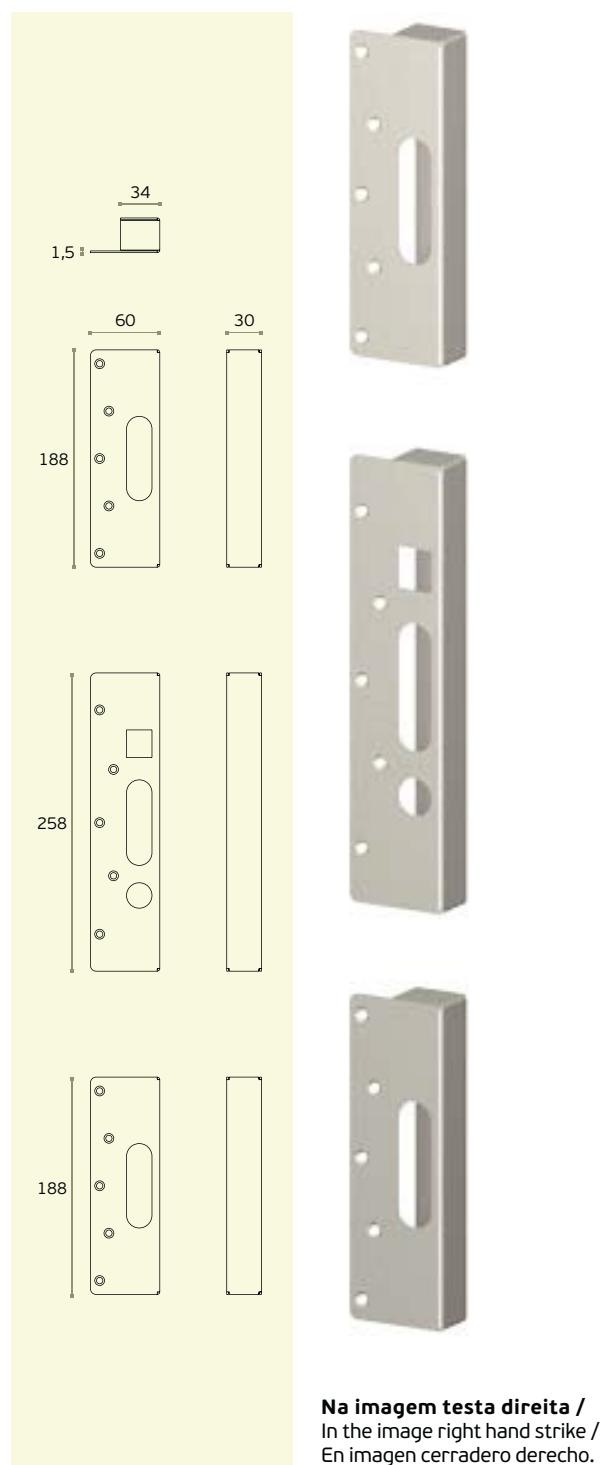

SÉRIE DE SEGURANÇA DE SOBREPOR / RIM SECURITY LOCKS SERIES / SERIE DE CERRADURAS DE SEGURIDAD DE SOBREPONER

A Série de segurança da JNF foi criada para ser utilizada em portas que estão sujeitas a uma utilização elevada.

JNF's Security Series was created to be applied in doors that have high use.

La serie de seguridad JNF fue creada para ser aplicada en puertas que se utilizan de un modo elevado.



GRADE
3

500 Mil
cycles

Caixa fechada aço inox EN.1.4301 /
Closed lock case made in stainless steel EN.1.4301 /
Caja cerrada en acero inoxidable EN.1.4301

Trinco reversível em aço inox EN 1.4301 /
Adjustable latch made in stainless steel EN 1.4301 /
Picaporte reversible en acero inox EN 1.4301.

Trancas de segurança em aço inox EN 1.4301 /
Security dead bolt made in stainless steel EN 1.4301 /
Bullones de seguridad en acero inox EN 1.4301.

Possível aplicar qualquer modelo de puxador JNF / Applicable with any JNF lever handle model /
Posibilidad de aplicar cualquier tipo de manilla JNF.

Cilindro Europeu /
European cylinder / Bombillo Europeo.

Caixa fechada aço inox EN.1.4301 /
Closed lock case made in stainless steel EN.1.4301 /
Caja cerrada en acero inoxidable EN.1.4301

Possível aplicação de diversos escudetes de segurança /
Possible to instal different security cylinder key holes /
Posible de aplicar distintos bocallaves de seguridad para bombillo.



Quadra em aço inox com mola interior para eliminação da folga entre o puxador e a quadra /
Stainless steel handle square hole with a internal spring to avoid any gap between the Spindle and the lock /
Nueca en acero inox con muelle interior para eliminar la holgura entre la manilla e la nueca

Furação para fixação do puxador /
Handle fixing holes /
Agujeros para tornillos pasantes.

IN.20.005.D - Direita / Right / Derecha
IN.20.005.E - Esquerda / Left / Izquierda

Fechadura de alta segurança de sobrepor /
Rim High security lock /
Cerradura de alta seguridad de sobreponer.

Material: EN 1.4301
Satinado / Satin / Satin

Aconselhamos cilindro com 90mm (60+30) +
Escudo de segurança Ref. IN.04.29S para
funcionamento correcto em portas de
30 a 40mm de espessura /
Recommended to use cylinder size 90mm (60+30) +
Security rose Ref. IN.04.29S for perfect function in doors
with thickness from 30 to 40mm /
Recomendamos utilización de cilindro con 90mm (60+30)
+ Escudo protector Ref. IN.04.29S para funcionamento
correcto en puertas de espesor entre 30 y 40mm.

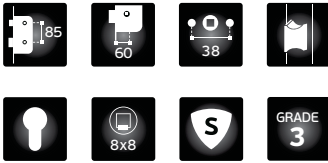

Na imagem fechadura esquerda /
In the image left hand lock /
En la imagen cerradura izquierda

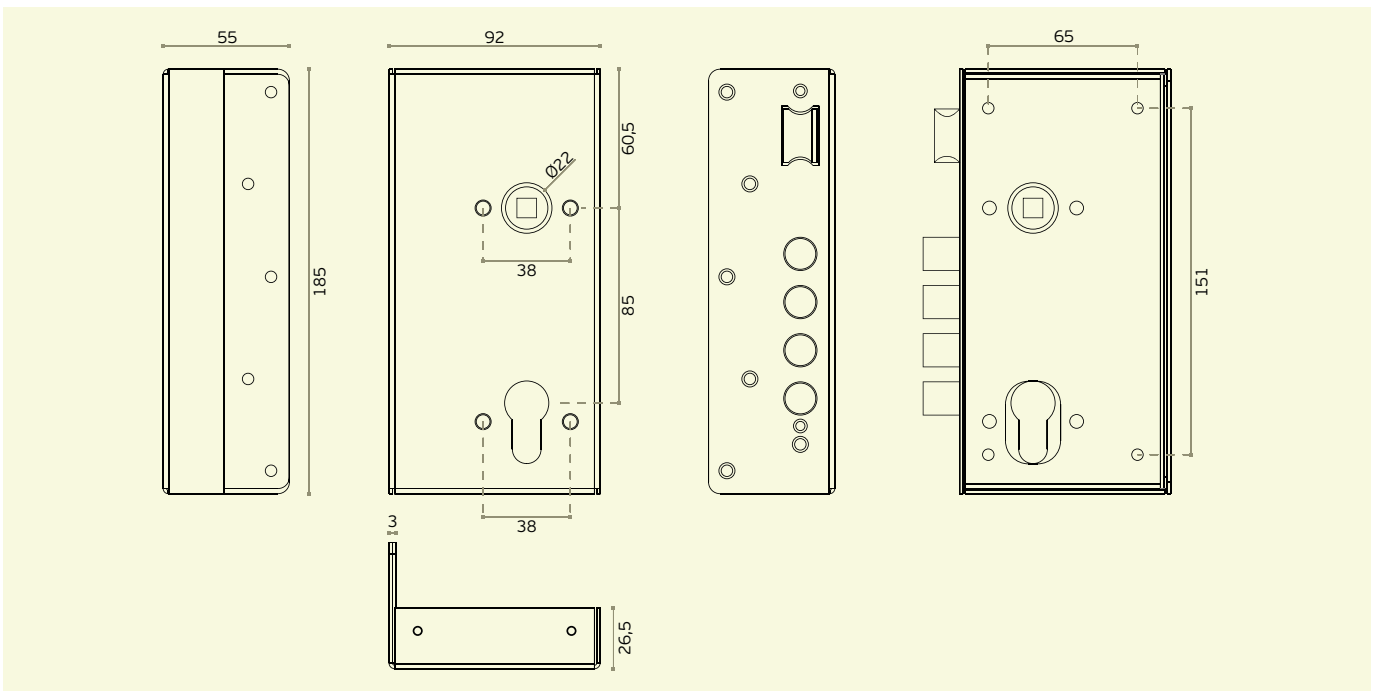

SÉRIE DE SEGURANÇA / SECURITY LOCKS SERIES / SERIE DE CERRADURAS DE SEGURIDAD

IN.20.006.D - Direita / Right / Derecha
IN.20.006.E - Esquerda / Left / Izquierda
 Chapa de testa para aplicar com IN.20.005 /
 Strike plate to install with IN.20.005 /
 Cerradero para instalar con IN.20.005.
Material: EN 1.4301
 Satinado / Satin / Satin



Na imagem testa direita /
 In the image right hand strike /
 En la imagen cerradero derecho

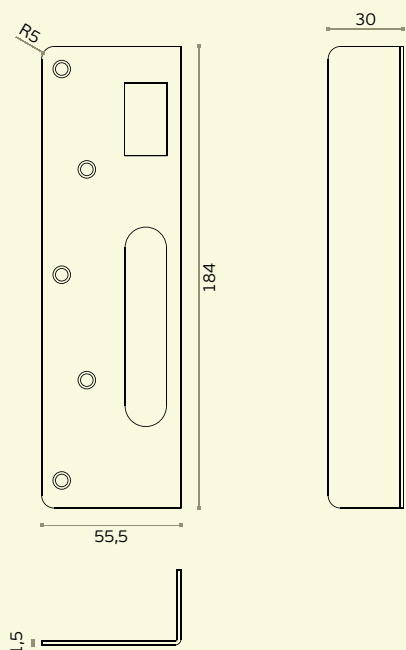

IN.20.007.D - Direita / Right / Derecha
IN.20.007.E - Esquerda / Left / Izquierda
 Chapa de testa reforçada para aplicar com IN.20.005 /
 Reinforced Strike plate to instal with IN.20.005 /
 Cerradero reforzado para instalar con IN.20.005.
Material: EN 1.4301
 Satinado / Satin / Satin



Na imagem testa direita /
 In the image right hand strike /
 En la imagen cerradero derecho

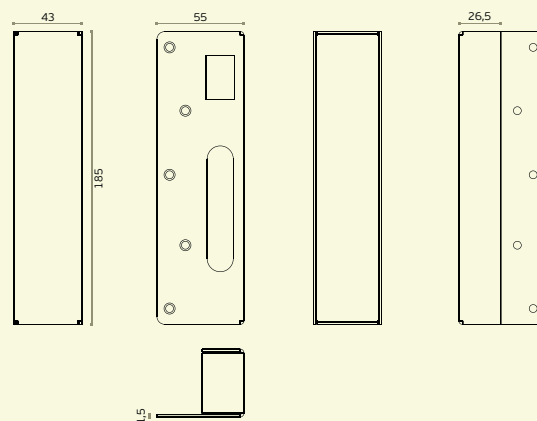



Escudetes de segurança / Security protection rose / Escudos de seguridad



IN.04.29S

Escudete de alta segurança ajustável para cilindro europeu. Sistema automático de ajuste à espessura da porta / High security protection rose for european cylinder. Automatic adjust to the thickness of the door / Escudo de alta seguridad ajustable para bombillo. Con ajuste automatico al espesor de la puerta.

Material: EN 1.4401 - Satinado/ Satin/ Satin

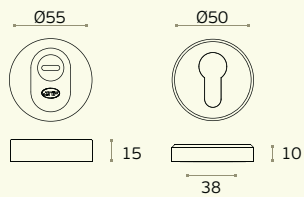

IN.04.31S

Escudete ajustável para cilindro europeu. Interior em aço temperado / Adjustable protection rose for european cylinder. Inner part made in hardened tempered steel / Escudo de seguridad ajustable para bombillo. Interior en acero templado.

Material: EN 1.4301 - Satinado/ Satin/ Satin

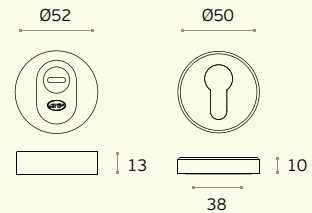

IN.04.32S

Escudete de segurança maciço ajustável para cilindro europeu com forma biselada / Adjustable protection rose for european cylinder. Solid stainless steel with chanfer edge / Escudo de seguridad ajustable para bombillo. En acero macizo en forma biselada.

Material: EN 1.4301 - Satinado / Satin / Satin

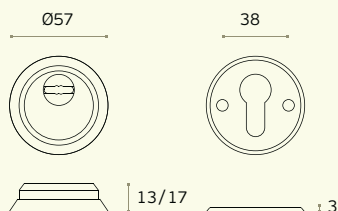

IN.04.40S

Escudete ajustável para cilindro europeu / Adjustable protection rose for european cylinder / Escudo de seguridad ajustable para bombillo europeu.

Material: EN 1.4401 - Satinado / Satin / Satin

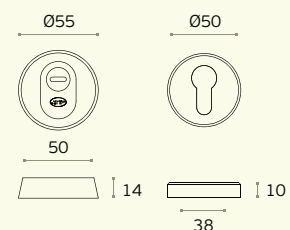



Escudetes de segurança /
Security protection rose / Escudos de seguridad



IN.04.36S
Escudete de segurança para cilindro europeu /
Security protection rose for european cylinder /
Escudo de seguridad para bombillo.
SÓLIDO / SOLID / MACIZO
Material: EN 1.4301 - Satinado / Satin / Satin

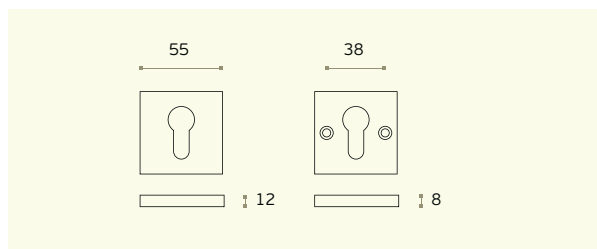

IN.04.37S / IN.04.37S.15
Escudete de segurança ajustável para cilindro europeu /
Adjustable security protection rose for european cylinder /
Escudo de seguridad ajustable para bombillo.
SÓLIDO / SOLID / MACIZO
Material: EN 1.4301 - Satinado / Satin / Satin

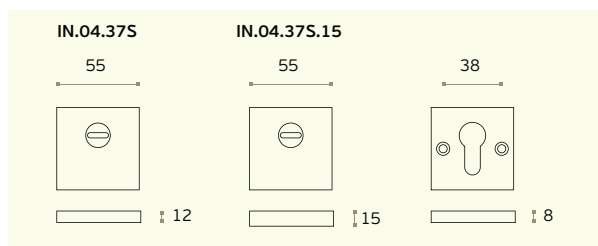

IN.04.38S
Escudete de segurança para cilindro europeu /
Security protection rose for european cylinder /
Escudo de seguridad para bombillo.
SÓLIDO / SOLID / MACIZO
Material: EN 1.4301 - Satinado / Satin / Satin

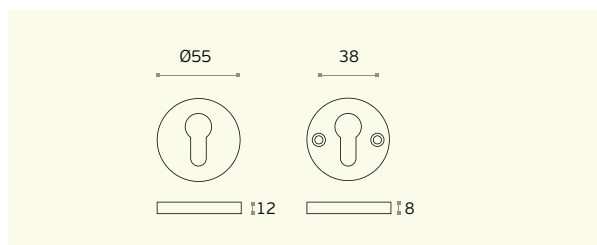

IN.04.39S / IN.04.39S.15
Escudete de segurança ajustável para cilindro europeu /
Adjustable security protection rose for european cylinder /
Escudo de seguridad ajustable para bombillo.
SÓLIDO / SOLID / MACIZO
Material: EN 1.4301 - Satinado / Satin / Satin

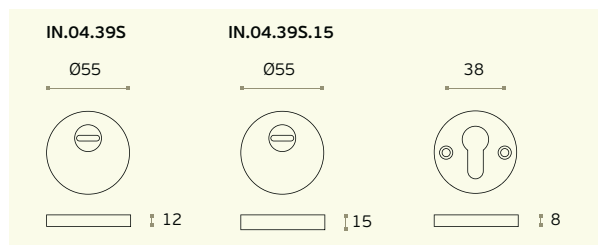



IN.04.30S

Escudete de alta segurança ajustável para cilindro europeu.
Sistema automático de ajuste à espessura da porta/ High security protection rose for european cylinder. Automatic adjust to the thickness of the door/ Escudo de alta seguridad ajustable para bombillo. Con ajuste automatico al espesor de la puerta.

Material: EN 1.4401 - Satinado/ Satin/ Satin

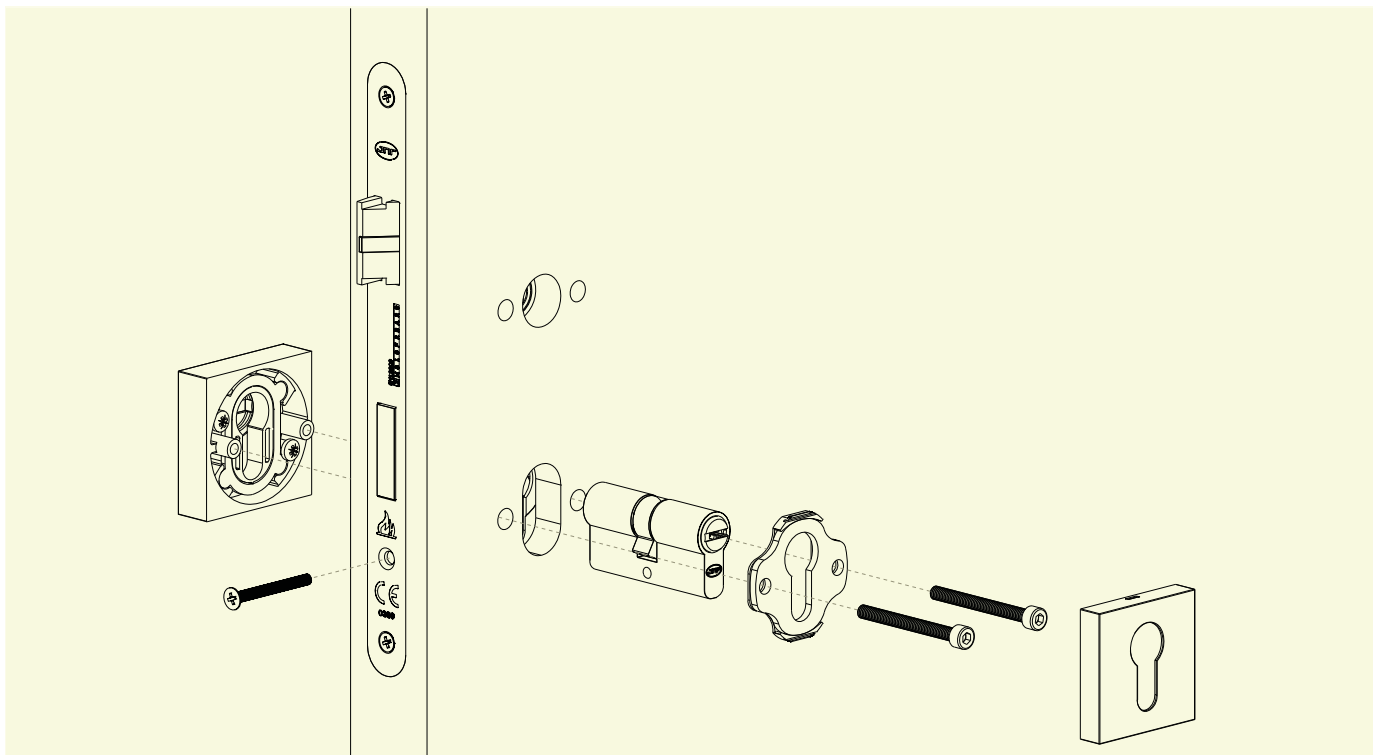
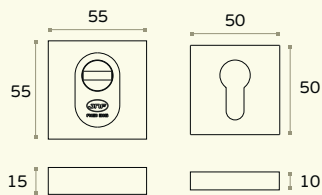

SÉRIE 990 / 990 SERIES / SERIE 990.

A Série 990 da JNF foi criada para ser utilizada em portas sujeitas a uma utilização elevada.

JNF's 990 Series was created to be applied in doors that have high use.

La serie 990 de JNF fue creada para puertas que se utilizan de un modo elevado.



500.000
cycles

Quadra com mola interior para eliminação da folga entre o puxador e a fechadura.

Em aço inox EN 1.4301/

Handle square hole with a internal spring to avoid any break between the Spindle and the lock.

Made in stainless steel EN 1.4301 /
Nueca en acero inox con muelle interior para eliminar la holgura entre la manilla y la cerradura. En acero inox EN 1.4301.

Furação para fixação do puxador /

Handle fixing holes /

Agujeros para tornillos pasantes.

Reforço no eixo de rotação/

Rotation axis reinforcement/

fortalecimiento del eje de rotación.

Caixa fechada/

Closed lock case /

Caja cerrada.



Trinco silencioso reversível em Nylon + Fibra de vidro e EN 1.4301.

Fecho suave/

Silent adjustable latch in Nylon + Fiber glass and EN 1.4301.

Smooth close/

Picaporte silencioso reversible en Nylon + Fibra de vidrio y EN 1.4301.

Cierre suave.

Disponível para rosetas Less is More /

Available for Less is More roses /

Disponibile para rosetas Less is More.

Língua em aço inox EN 1.4301/

Dead bolt made in stainless steel EN 1.4301/

Pestillo en acero inox EN 1.4301.

Frente em Aço Inox EN 1.4301/

Front plate made in Stainless steel EN 1.4301/

Frente en Acero inox EN 1.4301.



KI.20.995

Disponível KIT ignífugo para Serie 990/

Available fireproof KIT for 990 Series /

Available KIT prueba de fuego para Serie 990.

IN.20.995.R

Fechadura de embutir para cilindro europeu.
Indicada para portas com uso elevado /

Mortise door lock for european cylinder.
Recommended for doors with heavy use /

Cerradura de embutir para bombillo europeo.
Indicada para puertas con uso elevado.

Material: EN 1.4301
Satinado / Satin / Satin

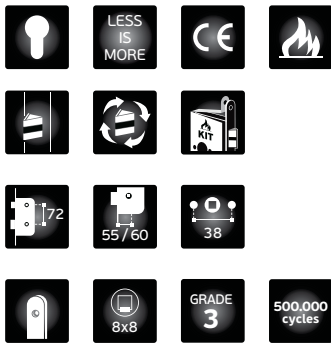

OPCIONAL/OPTIONAL

IN.20.AKN

Adaptador para chave normal.

Adapter for normal key.
Adaptador para llave normal.



OPCIONAL/OPTIONAL

IN.20.AWC

Converter para fechadura de casa de banho.

Converter for toilet lock.
Converter para cerradura de de condeña .

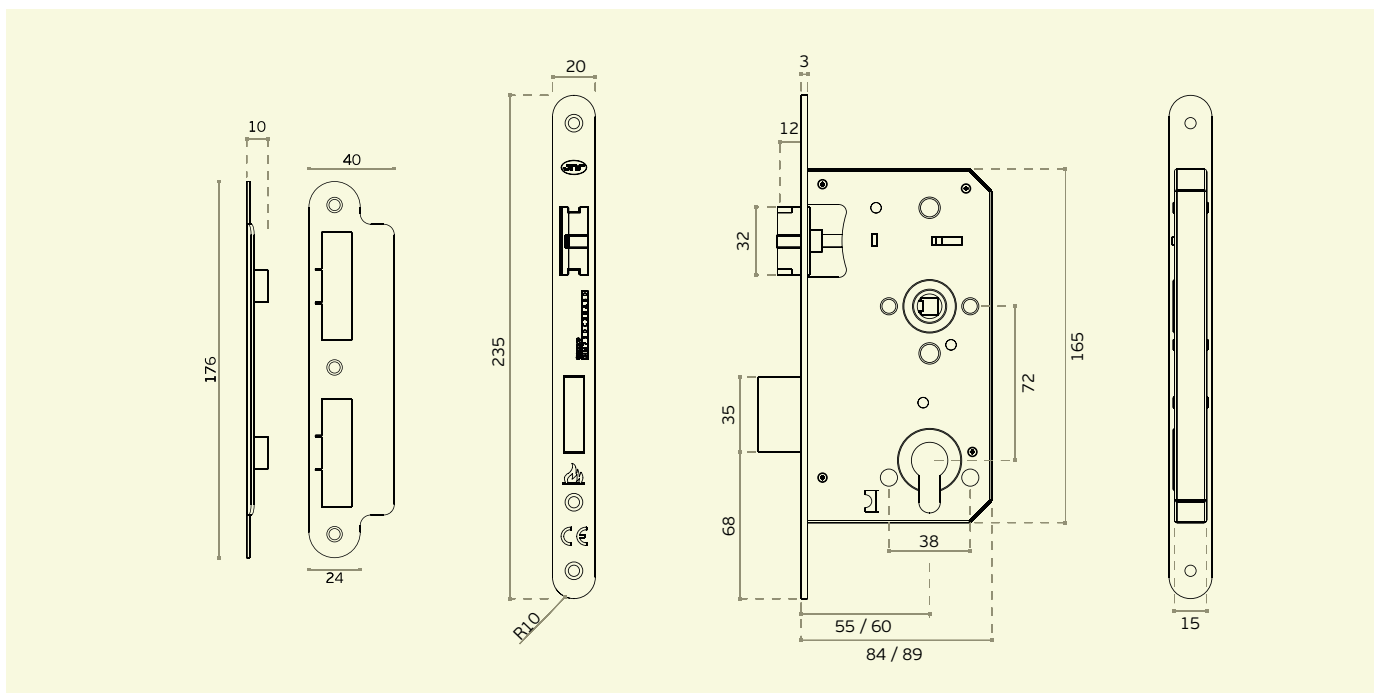

SÉRIE 990 / 990 SERIES / SERIE 990.

IN.20.996.R

Fechadura de embutir para casa de banho.
Indicada para portas com uso elevado /

Mortise door lock for bathroom use.
Recommended for doors with heavy use /

Cerradura de embutir para baño.
Indicada para puertas con uso elevado.

Material: EN 1.4301
Satinado / Satin / Satin

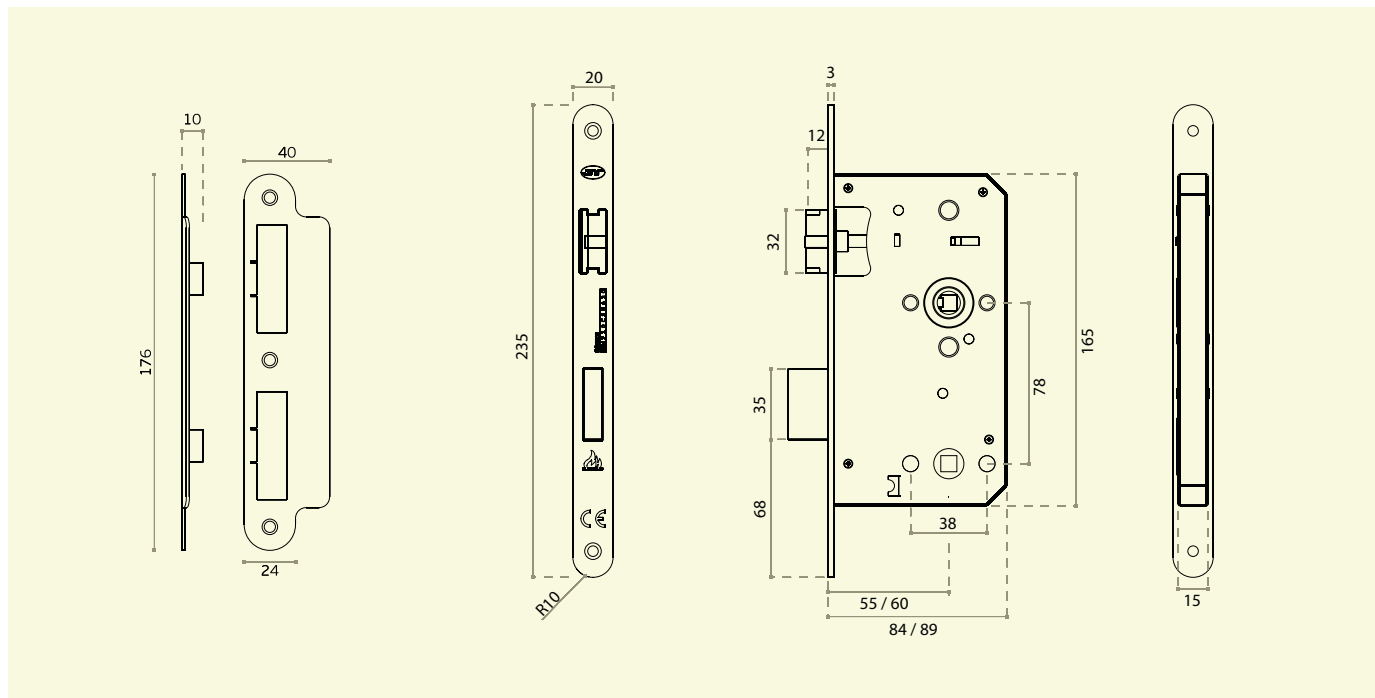
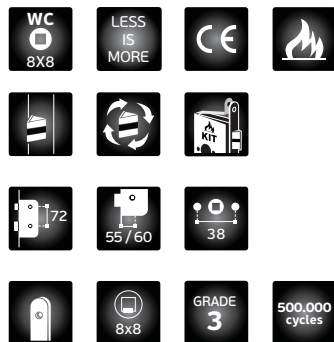

IN.20.997.R

Fechadura de embutir de passagem.
Indicada para portas com uso elevado /

Mortise door lock passage type.
Recommended for doors with high use /

Cerradura de embutir de paso.
Indicada para puertas con uso elevado.

Material: EN 1.4301
Satinado / Satin / Satin

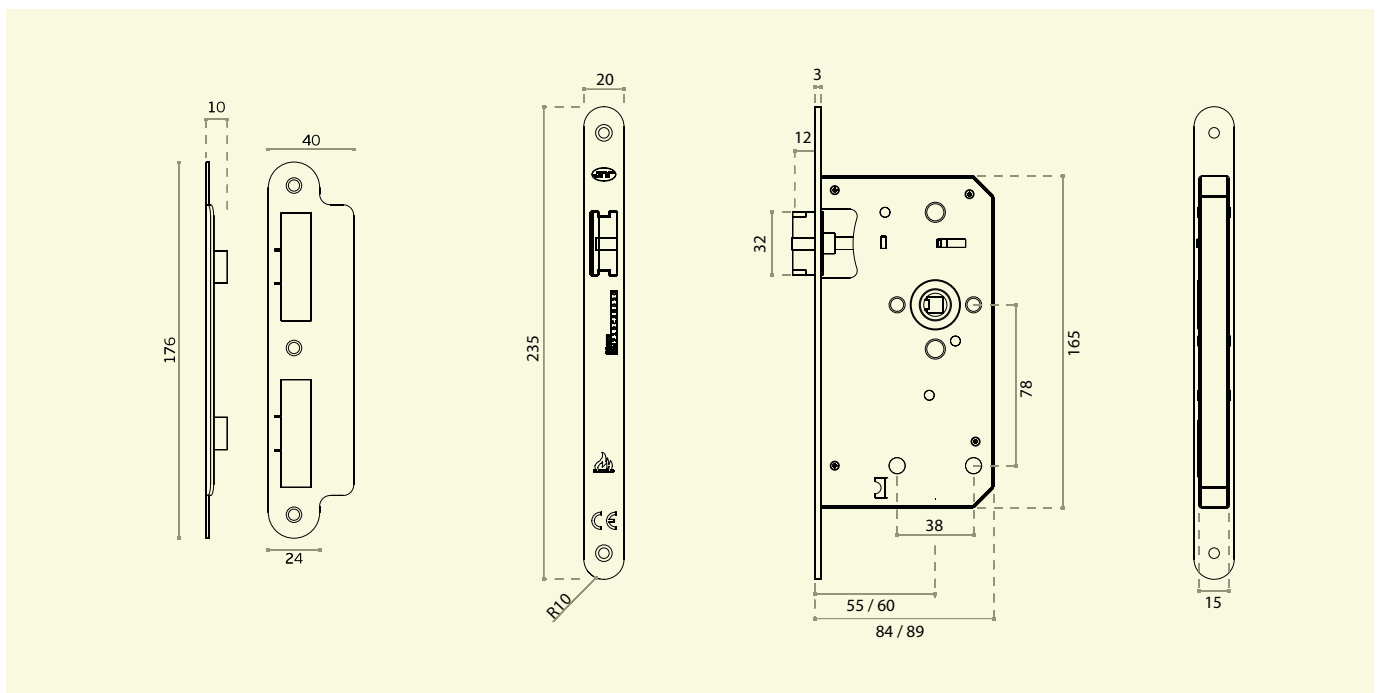
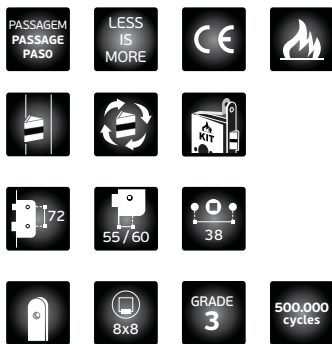

SÉRIE 600 / 600 SERIES / SERIE 600.

A fechadura IN.20.601 da JNF foi desenvolvida para ser utilizada em combinação com sistemas de controlo de acessos JNF. Trata-se de uma fechadura de grau 3 com certificação CE e corta fogo. Com garantia de 500.000 ciclos, esta fechadura é a escolha mais adequada para um hotel, um espaço comercial ou institucional onde a frequência de uso é elevada.

The JNF lock IN.20.601 was designed to be used in combination with JNF access control systems. This is a lock grade 3 with CE and fireproof certification. With guarantee of 500.000 cycles, this lock is the most suitable choice for an hotel, a commercial or institutional space where frequency of use is high.

La cerradura IN.20.601 fue desarrollada para ser utilizada en combinación con sistemas de control de acceso JNF. Se trata de una cerradura de grado 3 con certificación CE y prueba de fuego. Con garantía de 500.000 ciclos, esta cerradura es la opción más adecuada para un hotel, espacio comercial o institucional donde la frecuencia de uso es alta.

Quadra com com função anti-pânico.
Em aço inox EN 1.4301. /
Handle square hole with Antipanic function.
Made in stainless steel EN 1.4301. /
Nueca en acero inox con función antipánico.
En acero inox EN 1.4301.

Furação para fixação do puxador /
Handle fixing holes /
Agujeros para tornillos pasantes.

Contacto para ligação a controlo de acessos. Permite monitorizar a posição da língua da fechadura, passando essa informação para o sistema de controlo de acessos /
Switch for connection to access control. Allows monitoring the position of the dead bolt of the lock, passing this information to the access control system /
Contacto para la conexión con el control de acceso. Permite la monitorización de la posición de lo pestillo de la cerradura, pasando esta información al sistema de control de acceso

Caixa fechada /
Closed lock case /
Caja cerrada.

Trinco silencioso reversível com alavanca intermédia em aço inox EN 1.4301 /
Silent adjustable latch with inner lever made in stainless steel EN 1.4301 /
Picaporte silencioso reversible con palanca intermedia en acero inox EN 1.4301.

Pino de bloqueio anti-cartão em aço inox EN 1.4301 /
Locking pin anti-card stainless steel EN 1.4301 /
pasador de bloqueo anti-tarjeta en acero inoxidable EN 1.4301.

Língua em aço inox EN 1.4301 /
Dead bolt made in stainless steel EN 1.4301 /
Pestillo en acero inox EN 1.4301.

Frente em Aço Inox EN 1.4301 /
Front plate made in Stainless steel EN 1.4301 /
Frente en Acero inox EN 1.4301.



KI.20.601

Disponível KIT ignífugo para Serie 600 /
Available fireproof KIT for 600 Series /
Available KIT prueba de fuego para Serie 600.



IN.20.601
IN.20.601.R

Fechadura de embutir com switch para cilindro europeu certificada corta-fogo / fumo, função anti-pânico e indicada para portas com uso elevado. Marcação CE, Normas EN12209 / EN179 ///
Mortise door lock with switch for european cylinder with fire proof / smoke doors, with anti-panic function and recommended for doors with heavy use. CE marking, Norms EN12209 / EN179 ///

Cerradura de embutir con switch para bombillo europeo certificado corta fuego / humo, función antipánico y válido para puertas de alto uso. Marcado CE, EN12209 Norma y EN179.

Material: EN 1.4301
Satinado / Satin / Satin

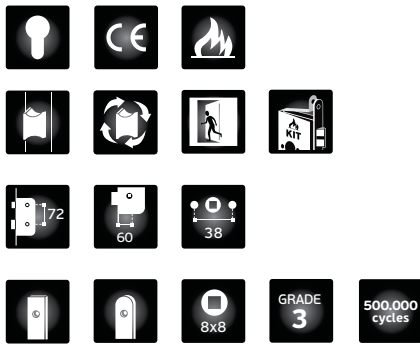

IN.20.601
Cantos rectos /
Straight corners / Cantos rectos.

IN.20.601.R
Cantos redondos /
Rounded corners / Cantos redondos.

OPCIONAL/OPTIONAL
IN.20.AKN
Adaptador para chave normal.

Adapter for normal key. Adaptador para llave normal.



OPCIONAL/OPTIONAL
IN.20.AWC
Conversor para fechadura de casa de banho.

Converter for toilet lock. Conversor para cerradura de de condeña .

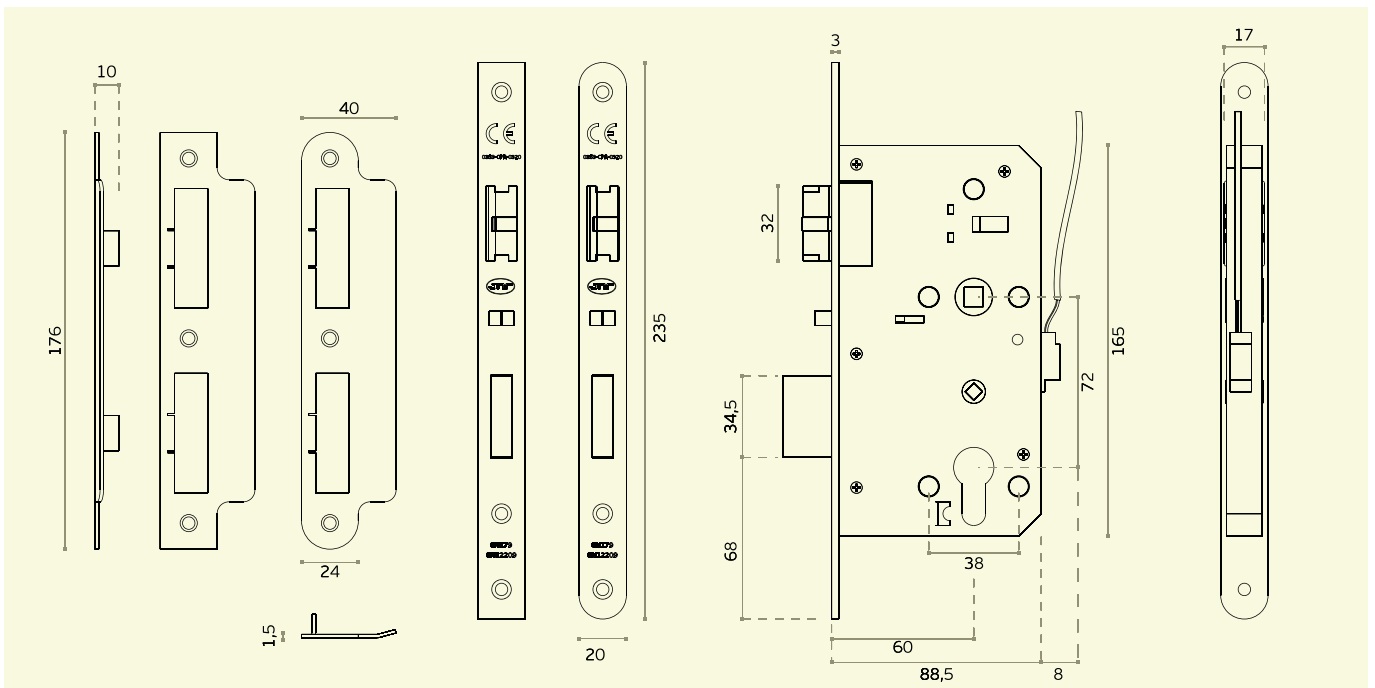

EN179 **3 7 6 B 1 4 4 2 A B**
EN12209 **3 M 8 1 0 F 2 B A 2 0**

SÉRIE 980 / 980 SERIES / SERIE 980.

A Série 980 da JNF foi criada para ser utilizada em portas que estão sujeitas a uma utilização elevada.

JNF's 980 Series was created to be applied in doors that have high use.

La serie 980 de JNF fue creada para ser aplicada en puertas que se utilizan de un modo elevado.



500.000
cycles



Quadra com mola interior para eliminação da folga entre o puxador e a fechadura.
Em aço inox EN 1.4301/
Handle square hole with a internal spring to avoid any break between the Spindle and the lock.
Made in stainless steel EN 1.4301 /
Nueca en acero inox con muelle interior para eliminar la holgura entre la manilla y la cerradura. En acero inox EN 1.4301.

Furação para fixação do puxador /
Handle fixing holes /
Agujeros para tornillos pasantes.

Disponível para rosetas Less is More /
Available for Less is More roses /
Disponible para rosetas Less is More.

Caixa fechada /
Closed lock case /
Caja cerrada.



Placa frontal de 20mm em aço inox EN 1.4301 / Front plate of 20 mm in stainless steel EN 1.4301 / Placa frontal de 20 mm de acero inoxidable EN 1.4301.

Trinco silencioso reversível com alavanca intermédia em aço inox EN 1.4301/
Silent adjustable latch with inner lever made in stainless steel EN 1.4301/
Picaporte silencioso reversible con palanca intermedia en acero inox EN 1.4301.

Chapa testa reversível /
Reversible strike plate /
Cerradero reversible.

Língua em aço inox EN 1.4301/
Dead bolt made in stainless steel EN 1.4301 /
Pestillo en acero inox EN 1.4301.

IN.20.985
IN.20.985.R

Fechadura de embutir para cilindro europeu.
Indicada para portas com uso elevado /

Mortise door lock for european cylinder.
Recommended for doors with heavy use /

Cerradura de embutir para bombillo europeu.
Indicada para puertas con uso elevado.

Material: EN 1.4301
Satinado / Satin / Satin

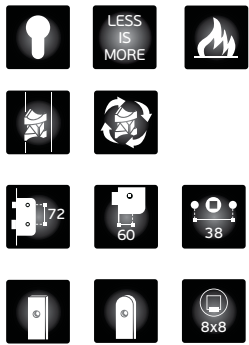

FIRE TEST EVIDENCE



IN.20.985
Cantos rectos /
Straight corners /
Cantos rectos.

IN.20.985.R
Cantos redondos /
Rounded corners /
Cantos redondos.

OPCIONAL/OPTIONAL
IN.20.AKN
Adaptador para chave normal.

Adapter for normal key.
Adaptador para llave normal.



OPCIONAL/OPTIONAL
IN.20.AWC
Converter para fechadura de casa de banho.

Converter for toilet lock.
Converter para cerradura de de condeña .

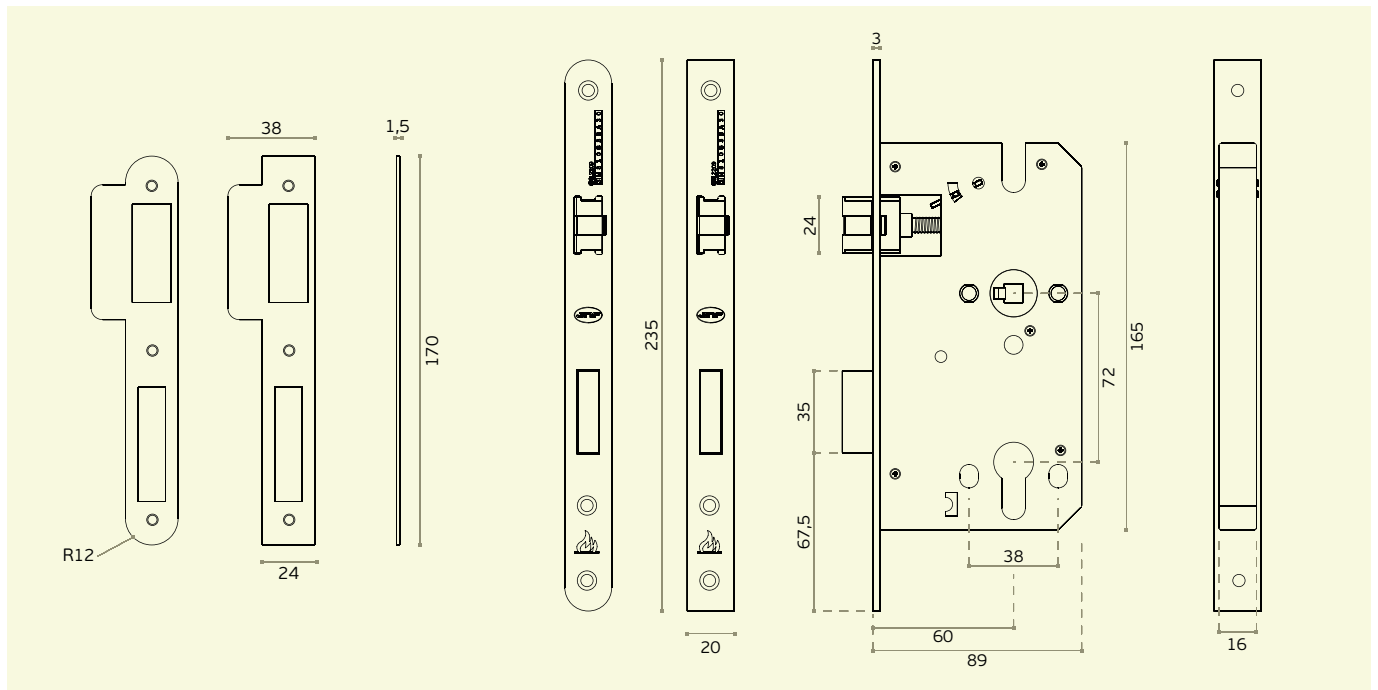

SÉRIE 980 / 980 SERIES / SERIE 980.

IN.20.986

IN.20.986.R

Fechadura de embutir para casa de banho.
Indicada para portas com uso elevado /

Mortise door lock for bathroom use.
Recommended for doors with heavy use /

Cerradura de embutir con condena para baño.
Indicada para puertas con uso elevado.

Material: EN 1.4301

Satinado / Satin / Satin

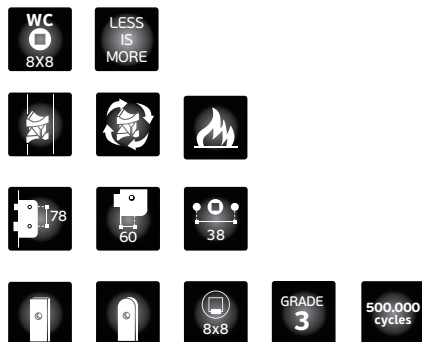

FIRE TEST EVIDENCE



IN.20.986
Cantos rectos /
Straight corners /
Cantos rectos.

IN.20.986.R
Cantos redondos /
Rounded corners /
Cantos redondos.

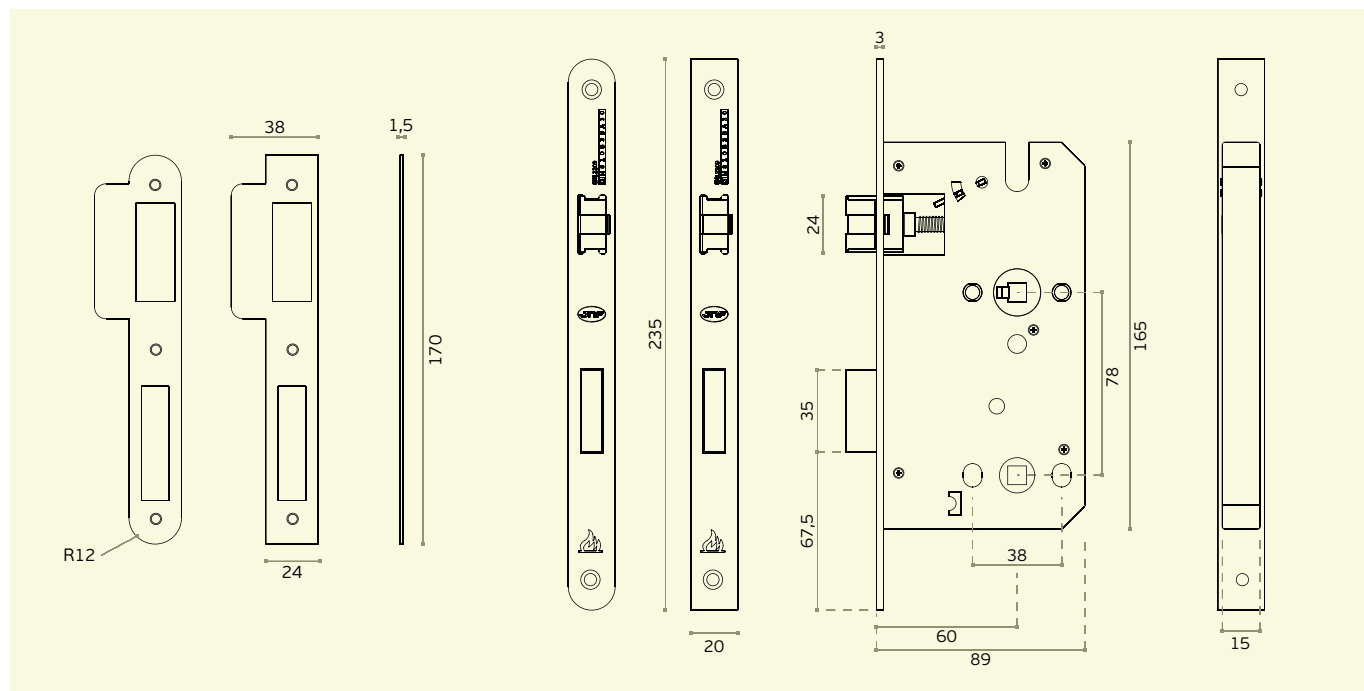

IN.20.987
IN.20.987.R

Fechadura de embutir de passagem.
Indicada para portas com uso elevado /

Mortise door lock passage type.
Recommended for doors with heavy use /

Cerradura de embutir de paso.
Indicada para puertas con uso elevado.

Material: EN 1.4301
Satinado / Satin / Satin



IN.20.987
Cantos rectos /
Straight corners /
Cantos rectos.

IN.20.987.R
Cantos redondos /
Rounded corners /
Cantos redondos.



FIRE TEST EVIDENCE

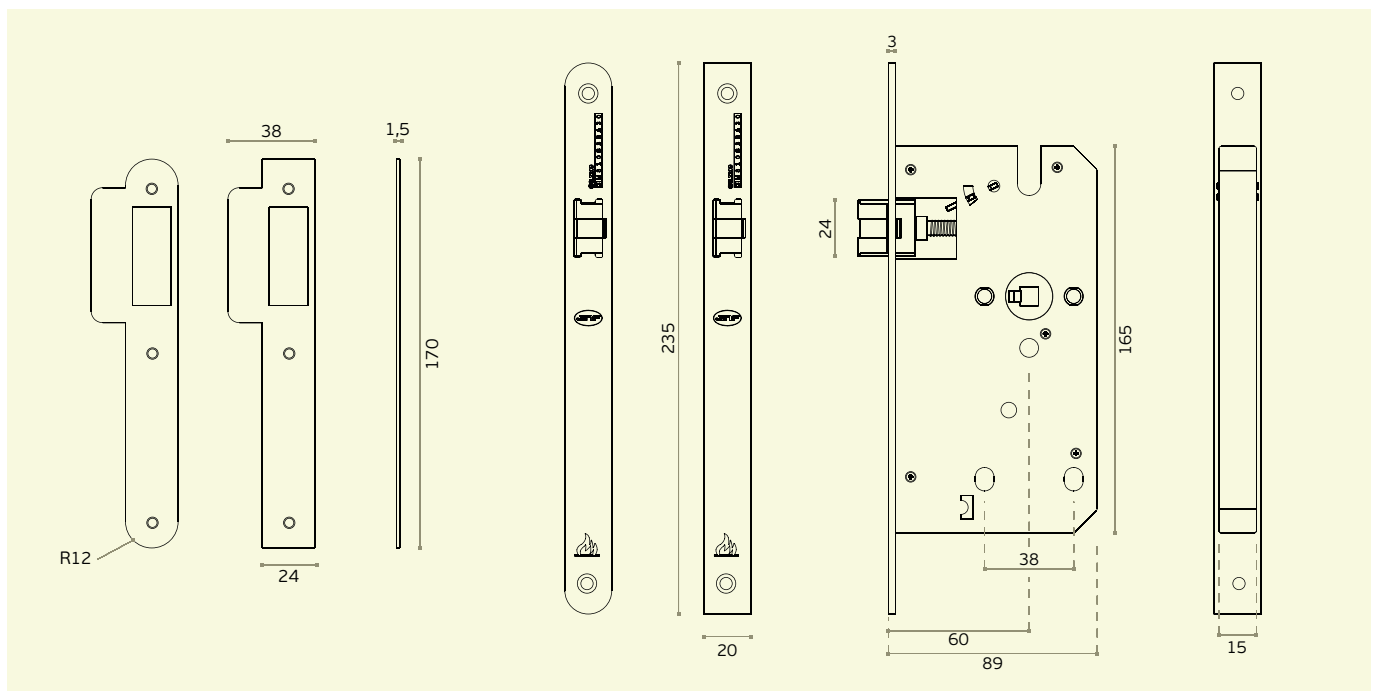

SÉRIE 970 / 970 SERIES / SERIE 970.

A Série 970 da JNF foi criada para ser utilizada em portas que estão sujeitas a uma utilização elevada.

JNF's 970 Series was created to be applied in doors that have high use.

La serie 970 de JNF fue creada para ser aplicada en puertas que se utilizan de un modo elevado.



500.000
cycles

Quadra com mola interior para eliminação da folga entre o puxador e a fechadura.
Em aço inox EN 1.4301/
Handle square hole with a internal spring to avoid any break between the Spindle and the lock.
Made in stainless steel EN 1.4301 /
Nueca en acero inox con muelle interior para eliminar la holgura entre la manilla y la cerradura. En acero inox EN 1.4301.

Furação para fixação do puxador /
Handle fixing holes /
Agujeros para tornillos pasantes.

Disponível para rosetas Less is More /
Available for Less is More roses /
Disponible para rosetas Less is More.

Caixa fechada/
Closed lock case /
Caja cerrada.

Trinco reversível em aço inox EN 1.4301/
Adjustable latch made in stainless steel EN 1.4301/
Picaporte reversible en acero inox EN 1.4301.

Chapa testa reversível /
Reversible strike plate /
Cerradero reversible.

Língua em aço inox EN 1.4301/
Dead bolt made in stainless steel EN 1.4301 /
Pestillo en acero inox EN 1.4301.

Frente em Aço Inox EN 1.4301/
Front plate made in Stainless steel EN 1.4301 /
Frente en Acero inox EN 1.4301.

IN.20.975

Fechadura de embutir para cilindro europeu.
Indicada para portas com uso elevado /

Mortise door lock for european cylinder.
Recommended for doors with heavy use /

Cerradura de embutir para bombillo europeo.
Indicada para puertas con uso elevado.

Material: EN 1.4301
Satinado / Satin / Satin

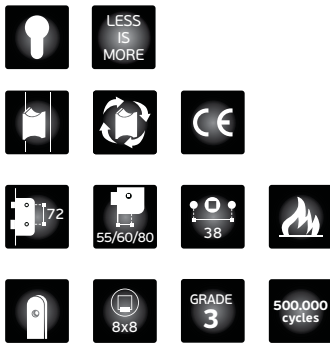

OPCIONAL/OPTIONAL

IN.20.AKN

Adaptador para chave normal.

Adapter for normal key.
Adaptador para llave normal.



OPCIONAL/OPTIONAL

IN.20.AWC

Converter para fechadura de casa de banho.

Converter for toilet lock.
Converter para cerradura de de condeña .

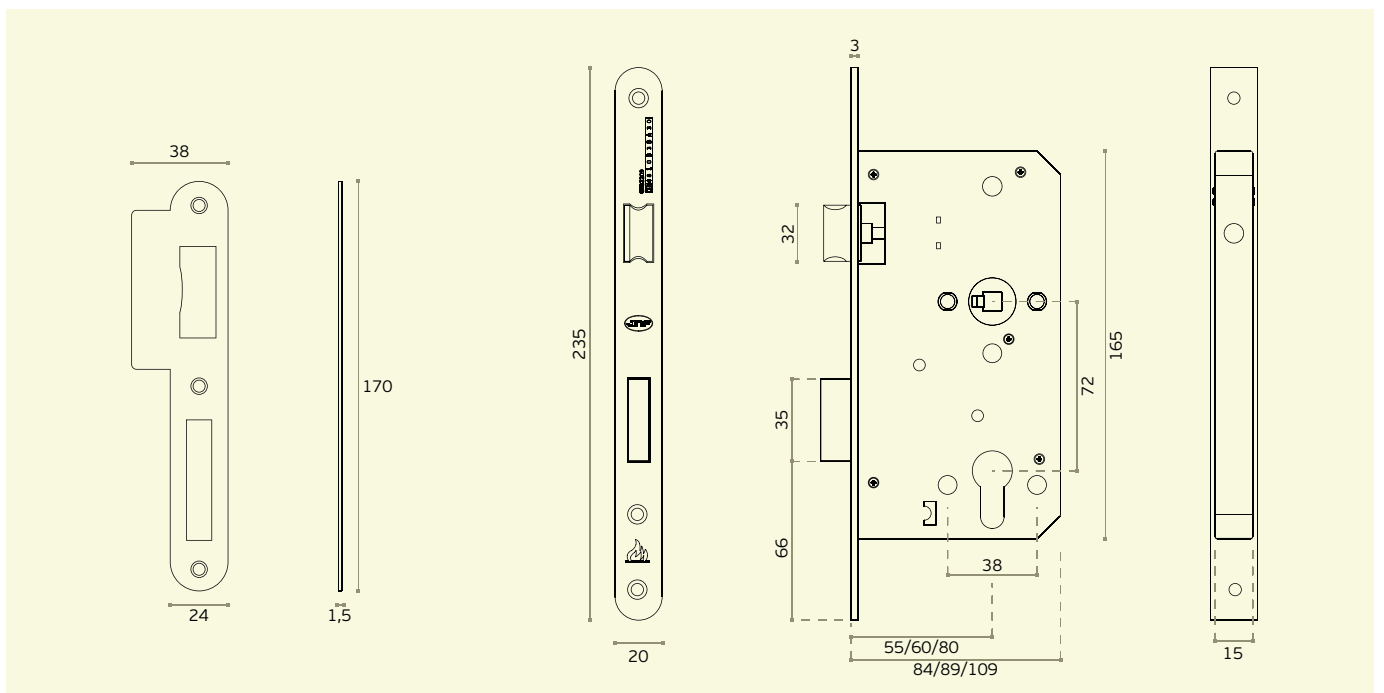

SÉRIE 970 / 970 SERIES / SERIE 970.

IN.20.976

Fechadura de embutir para casa de banho.
Indicada para portas com uso elevado /

Mortise door lock for bathroom use.
Recommended for doors with heavy use /

Cerradura de embutir para condena de baño.
Indicada para puertas con uso elevado.

Material: EN 1.4301
Satinado / Satin / Satin

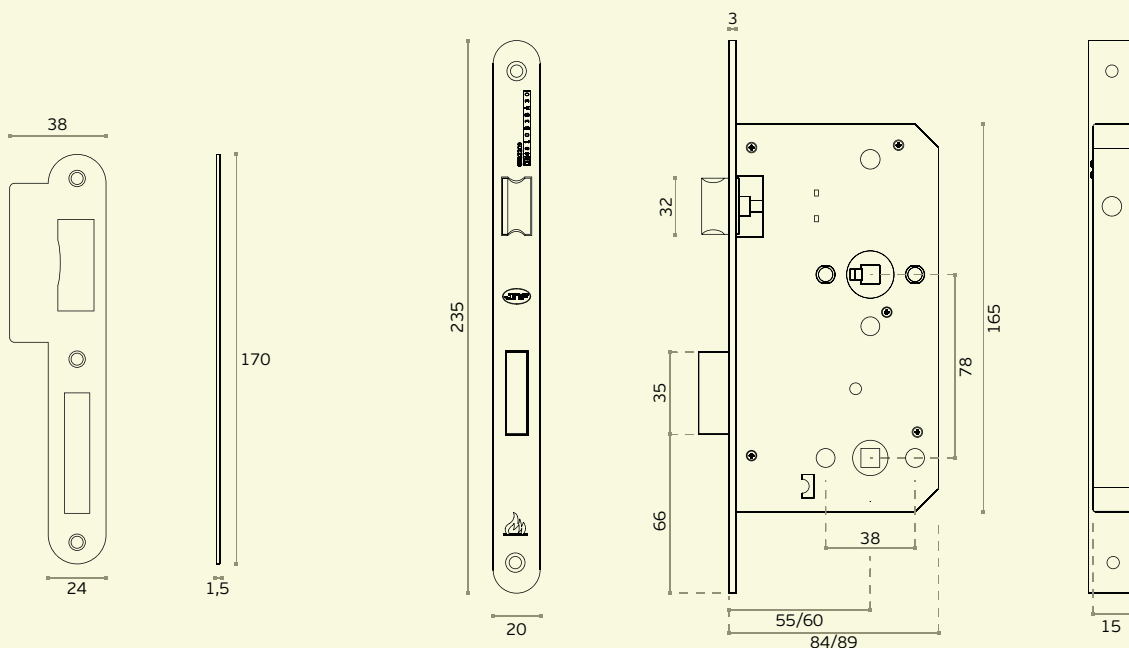
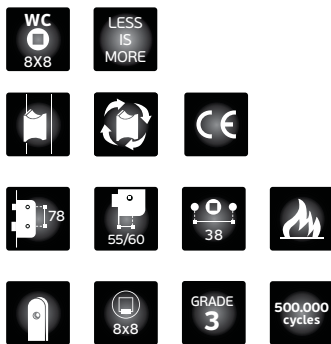

IN.20.977

Fechadura de embutir de passagem.
Indicada para portas com uso elevado /

Mortise door lock passage type.
Recommended for doors with heavy use /

Cerradura de embutir de paso.
Indicada para puertas con uso elevado.

Material: EN 1.4301
Satinado / Satin / Satin

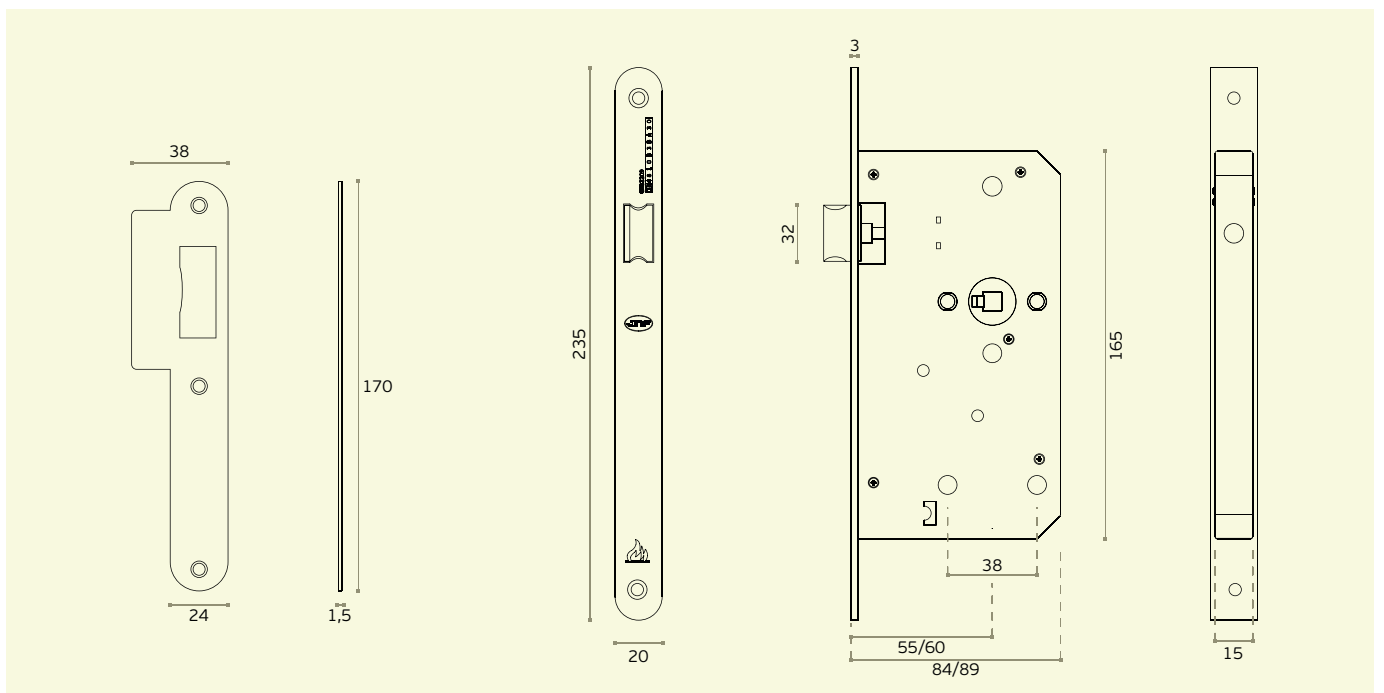
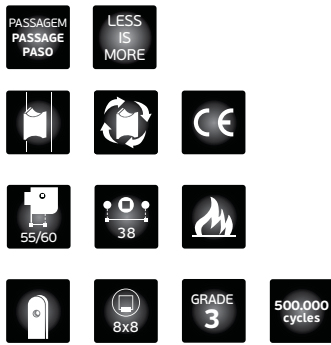

SÉRIE 970 / 970 SERIES / SERIE 970.

IN.20.978

Fechadura de embutir para cilindro europeu e sem trinco.

Indicada para portas com uso elevado /

Mortise door lock for european cylinder and without latch.

Recommended for doors with heavy use /

Cerradura de embutir para bombillo europeo y sin picaporte.

Indicada para puertas con uso elevado.

Material: EN 1.4301

Satinado / Satin / Satin

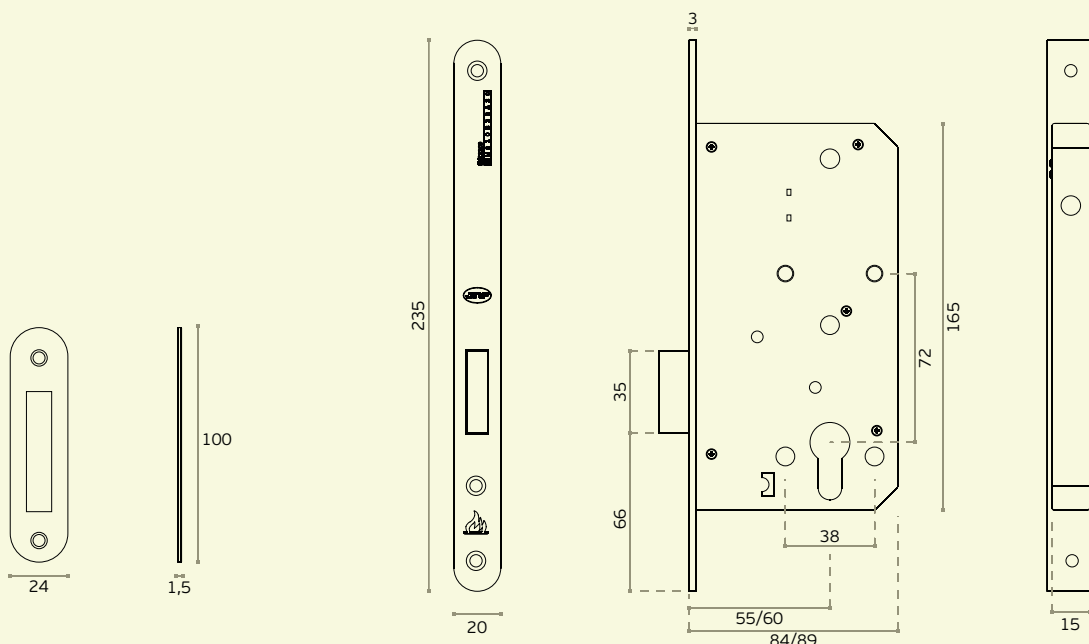

IN.20.973

Fechadura de serviço /
Lock Service /
Cerradura de servicio /

Material: EN 1.4301
Satinado / Satin / Satin

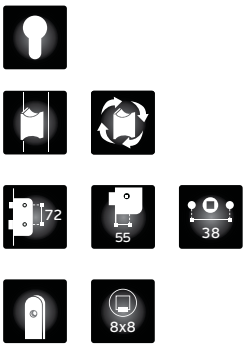

OPCIONAL/OPTIONAL

IN.20.AKN

Adaptador para chave normal.

Adapter for normal key.
Adaptador para llave normal.



OPCIONAL/OPTIONAL

IN.20.AWC

Converter para fechadura de casa de banho.

Converter for toilet lock.
Converter para cerradura de de condeña .

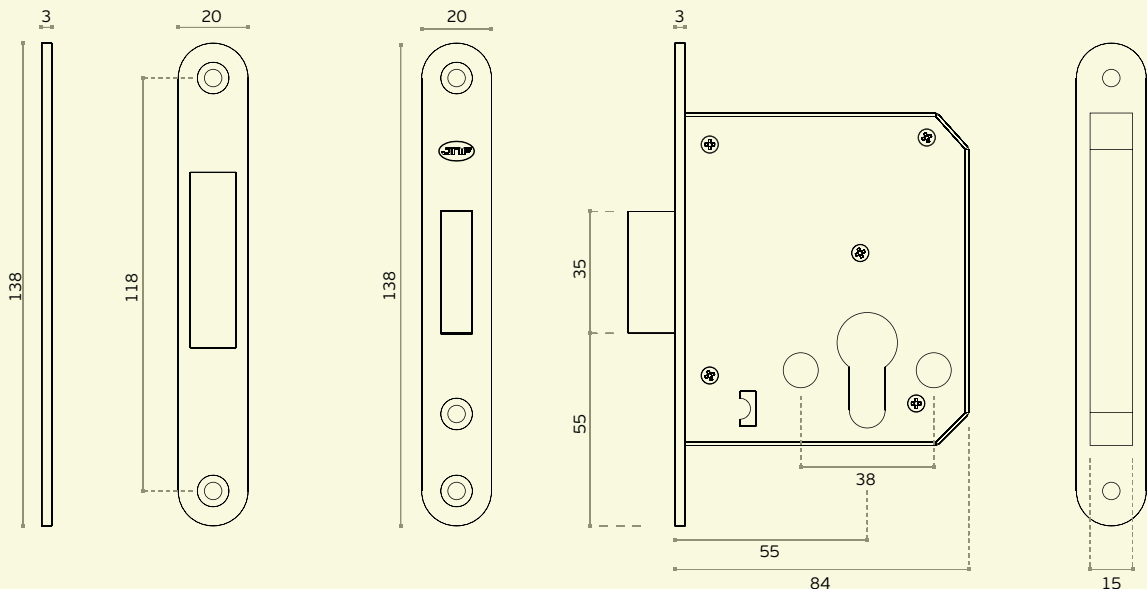

SÉRIE 270 / 270 SERIES / SERIE 270.

A Série 270 da JNF foi desenvolvida com o objetivo de criar uma fechadura com distancia entre eixos de 72mm, mas com uma caixa de dimensões reduzidas, mantendo a classe 3 que caracteriza este tipo de fechadura.

The 270 JNF Series was developed with the aim of creating a lock with distance between centers of 72mm but with a small size box, while keeping the class 3 which characterizes this type of lock.

La serie 270 JNF fue desarrollado con el objetivo de crear una cerradura con distancia entre ejes de 72 mm, pero con una caja de pequeño tamaño mientras se mantiene la clase 3, que caracteriza a este tipo de cerradura.

Quadra com mola interior para eliminação da folga entre o puxador e a fechadura /
Handle square hole with a internal spring to avoid any break between the Spindle and the lock. /
Nueca en acero inox con muelle interior para eliminar la holgura entre la manilla y la cerradura.

Furação para fixação do puxador /
Handle fixing holes /
Agujeros para tornillos pasantes.

Caixa fechada /
Closed lock case /
Caja cerrada.



Trinco reversível em aço inox EN 1.4301 /
Adjustable latch made in stainless steel EN 1.4301 /
Picaporte reversible en acero inox EN 1.4301.

Língua em aço inox EN 1.4301 /
Dead bolt made in stainless steel EN 1.4301 /
Pestillo en acero inox EN 1.4301.

Fronte em Aço Inox EN 1.4301 /
Front plate made in Stainless steel EN 1.4301 /
Frente en Acero inox EN 1.4301.

IN.20.275

Fechadura de embutir para cilindro europeu.
Indicada para portas com uso elevado /

Mortise door lock for european cylinder.
Recommended for doors with heavy use /

Cerradura de embutir para bombillo europeo.
Indicada para puertas con uso elevado.

Material: EN 1.4301
Satinado / Satin / Satin



FIRE TEST EVIDENCE



OPCIONAL/OPTIONAL

IN.20.AKN

Adaptador para chave normal.

Adapter for normal key.
Adaptador para llave normal.



IN.20.AWC

Adaptador para fecho WC /
Adapter for snib indicator /
Adaptador para condena de baño.

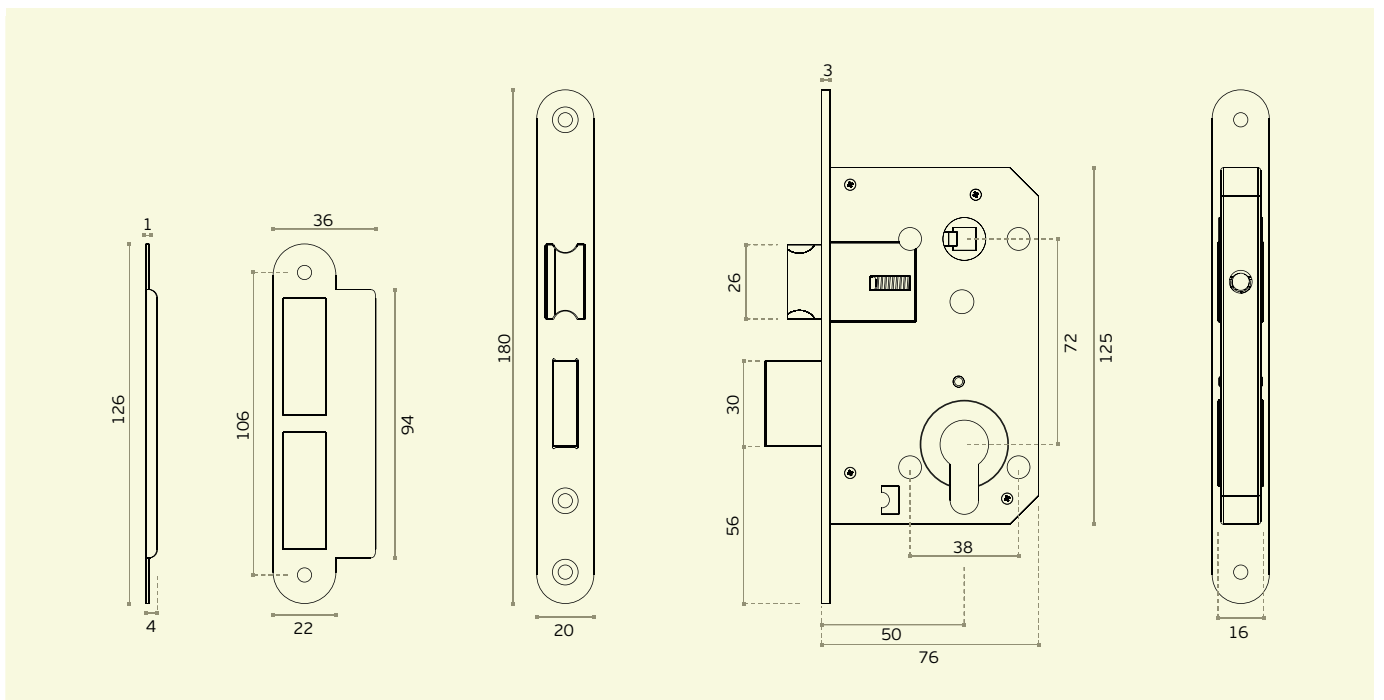

SÉRIE 890 / 890 SERIES / SERIE 890.

A Série 890 foi desenvolvida com o objectivo de se criar uma linha de fechaduras extremamente robustas, mas simultaneamente versátil de modo que fosse possível ter frentes intercambiáveis por outros acabamentos e formas.

890 Series was developed with the objective of if creating a line of locks extremely reliable, but simultaneously versatile in way that was possible to replace fronts with distinct materials and patterns.

La serie 890 fue desarrollada con el objetivo de obtener una línea de cerraduras extremadamente versátiles, manera que sea posible substituir las frentes por otros acabados o formas.

Quadra com mola interior para eliminação da folga entre o puxador e quadra / Handle square hole with a internal spring to avoid any break between the Spindle and the lock / Nueca en acero inox con muelle interior para eliminar la holgura entre la manilla y nueca.

Furação para fixação do puxador / Handle fixing holes / Agujeros para tornillos pasantes.

Língua em aço inox EN 1.4301 / Dead bolt made in stainless steel EN 1.4301 / Pestillo en acero inox EN 1.4301.

Cantos rectos ou redondos / Straight or rounded corners / Cantos rectos o redondos.

Placa frontal de 24 mm em aço inox EN 1.4301 / Front plate of 24 mm in stainless steel EN 1.4301 / Placa frontal de 24 mm de acero inoxidable EN 1.4301.

Trinco silencioso reversível com alavanca intermédia em aço inox EN 1.4301 / Silent adjustable latch with inner lever made in stainless steel EN 1.4301 / Picaporte silencioso reversible con palanca intermedia en acero inox EN 1.4301.

Chapa testa reversível / Reversible strike plate / Cerradero reversible.

Frente em Inox escovado, pode ser substituída por outros materiais como Latão, Bronze, Inox polido e acabamentos em Titânio / Front plate made in Stainless steel that can be replaced for other materials such as Solid Brass, Antique Bronze, Polished stainless steel and finished in Titanium / Frente en acero inox que puede ser sustituido por otros materiales como Latón, Bronce, Inox Pulido y acabado en titanio.

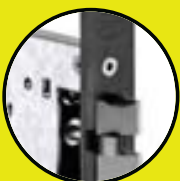

IN.20.89_TB
IN.20.89_R.TB
TITANIUM BLACK



IN.20.89_TG
IN.20.89_R.TG
TITANIUM GOLD



IN.20.89_TCO
IN.20.89_R.TCO
TITANIUM COPPER



IN.20.89_P
IN.20.89_R.P
POLISHED / POLIDO

IN.20.895
IN.20.895.R

Fechadura de embutir para cilindro europeu.
Indicada para portas com uso elevado /

Mortise door lock for european cylinder.
Recommended for doors with heavy use /

Cerradura de embutir para bombillo europeo.
Indicada para puertas con uso elevado.

Material: EN 1.4301
Satinado / Satin / Satin

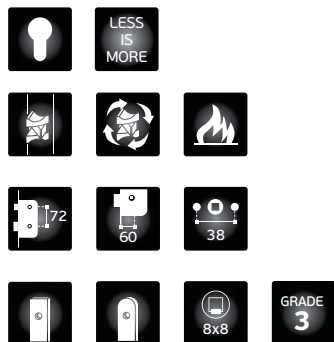

FIRE TEST EVIDENCE



IN.20.895
Cantos rectos /
Straight corners /
Cantos rectos.

IN.20.895.R
Cantos redondos /
Rounded corners /
Cantos redondos.

OPCIONAL/OPTIONAL
IN.20.AKN
Adaptador para chave normal.

Adapter for normal key.
Adaptador para llave normal.



OPCIONAL/OPTIONAL
IN.20.AWC
Convertor para fechadura de casa de banho.

Converter for toilet lock.
Convertor para cerradura de de condeña .

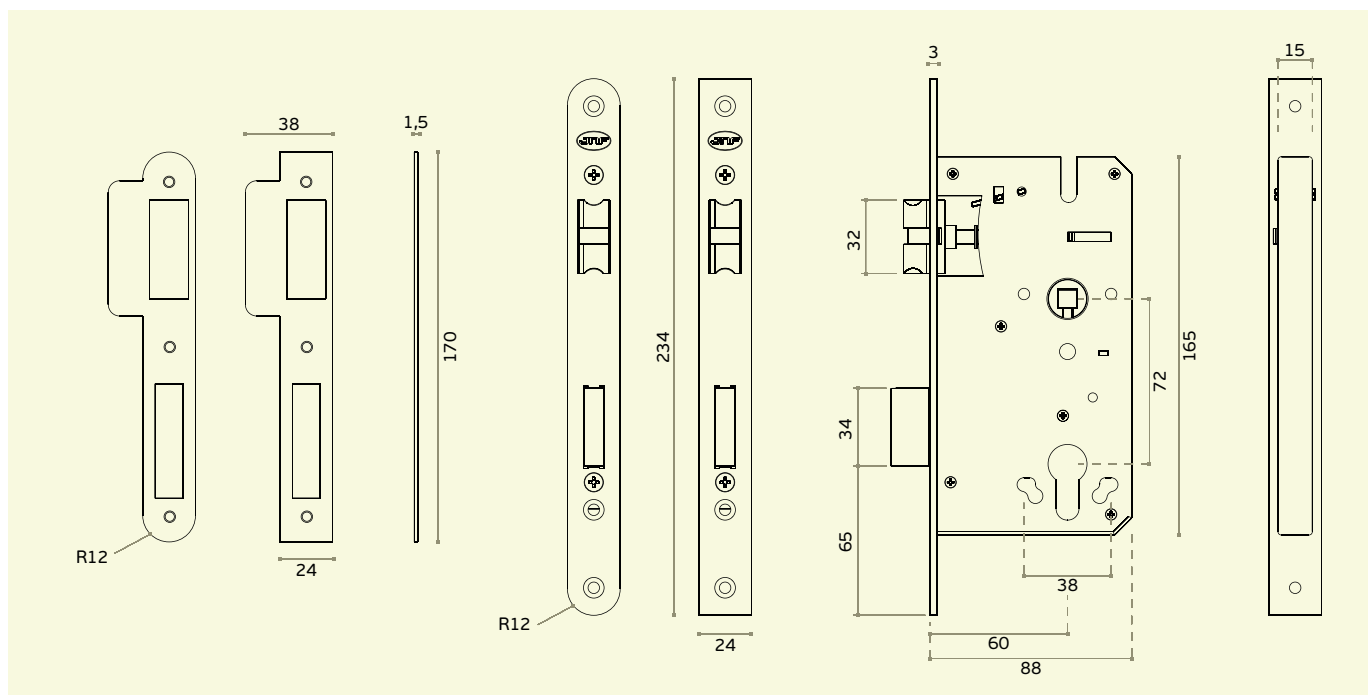

SÉRIE 890 / 890 SERIES / SERIE 890.

IN.20.896

IN.20.896.R

Fechadura de embutir para casa de banho.
Indicada para portas com uso elevado /

Mortise door lock for bathroom use.
Recommended for doors with heavy use /

Cerradura de embutir para baño.
Indicada para puertas con uso elevado.

Material: EN 1.4301

Satinado / Satin / Satin



FIRE TEST EVIDENCE



IN.20.896
Cantos rectos /
Straight corners /
Cantos rectos.

IN.20.896.R
Cantos redondos /
Rounded corners /
Cantos redondos.

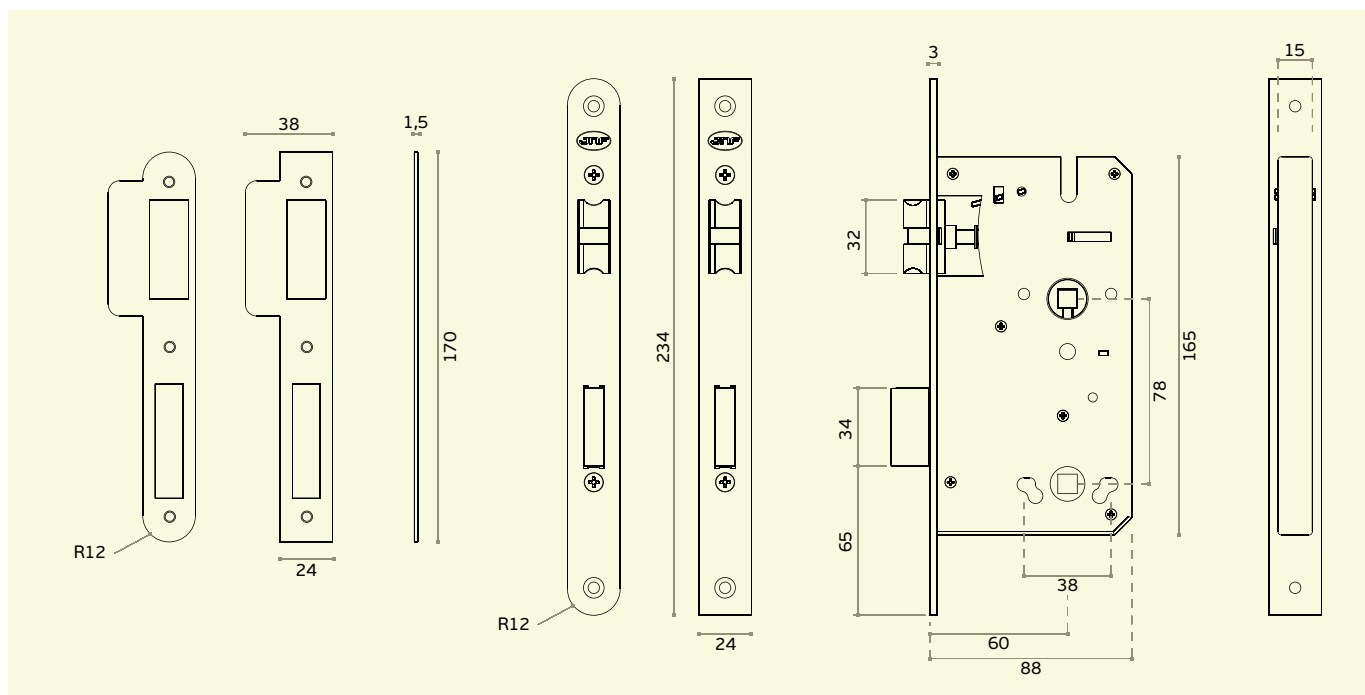

IN.20.897
IN.20.897.R

Fechadura de embutir de passagem.
Indicada para portas com uso elevado /

Mortise door lock passage type.
Recommended for doors with high use /

Cerradura de embutir de paso.
Indicada para puertas con uso elevado.

Material: EN 1.4301
Satinado / Satin / Satin



FIRE TEST EVIDENCE



IN.20.897
Cantos
rectos /
Straight
corners /
Cantos
rectos.

IN.20.897.R
Cantos
redondos /
Rounded
corners /
Cantos
redondos.

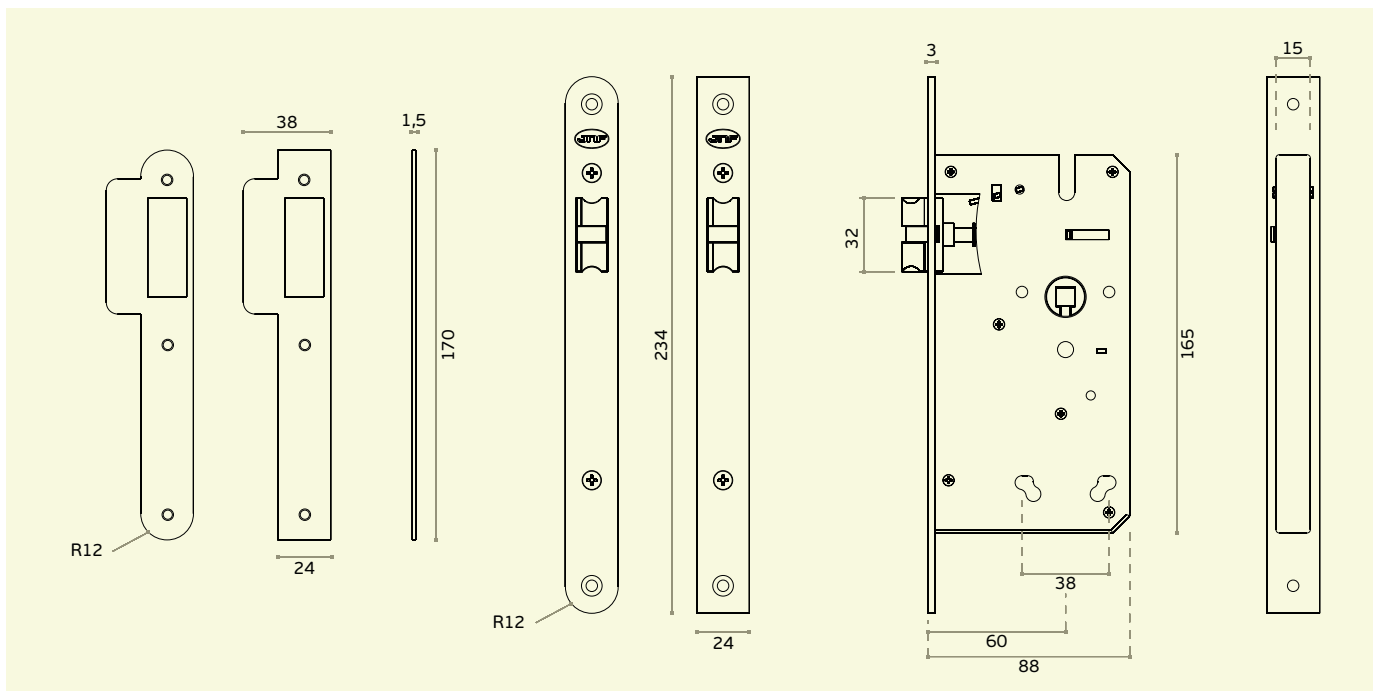

SÉRIE 890 / 890 SERIES / SERIE 890.

IN.20.898

IN.20.898.R

Fechadura de embutir com chave normal.
Chave com 12 combinações.
Indicada para portas com uso elevado /

Mortise door lock with normal key.
Key with 12 combinations.
Recommended for doors with heavy use /

Cerradura de embutir con llave normal.
Llave con 12 combinaciones.
Indicada para puertas con uso elevado.

Material: EN 1.4301

Satinado / Satin / Satin



 **FIRE TEST EVIDENCE**



IN.20.898
Cantos rectos /
Straight corners /
Cantos rectos.

IN.20.898.R
Cantos redondos /
Rounded corners /
Cantos redondos.

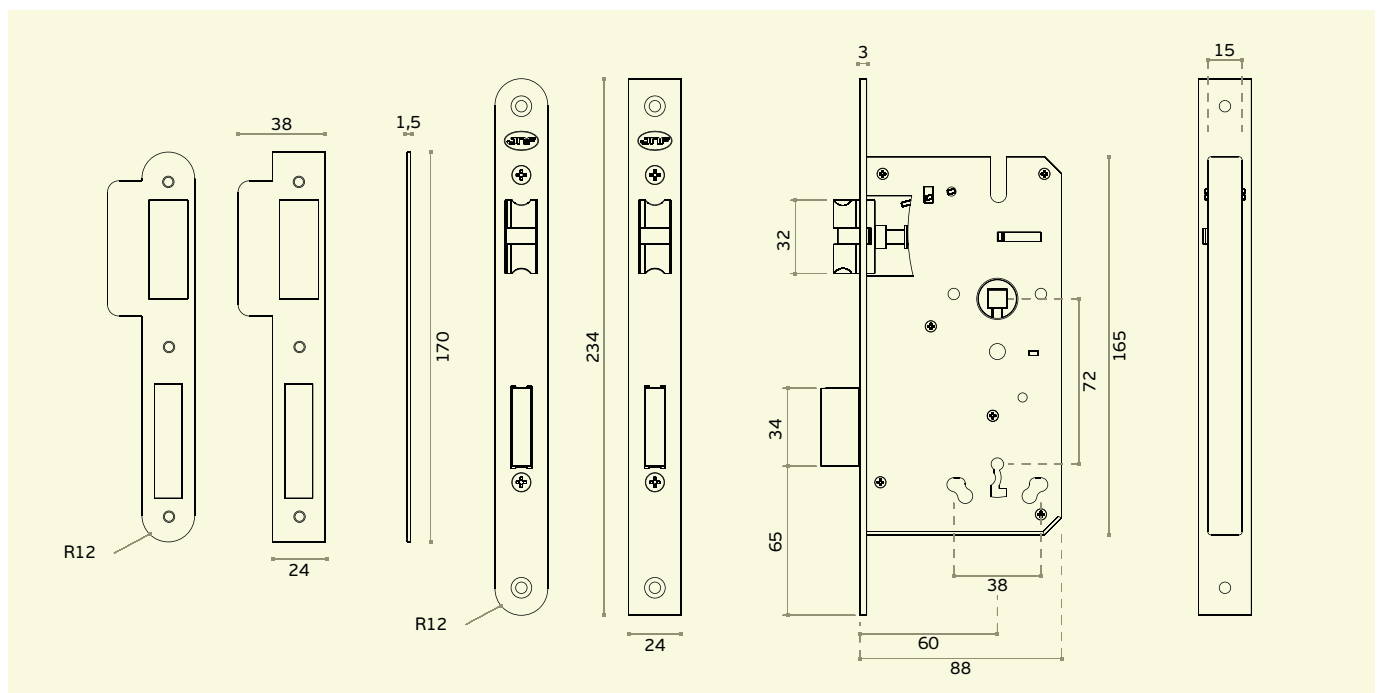

IN.20.894

Fechadura de embutir de rolete para cilindro europeu.
Indicada para portas com uso elevado /

Mortise door lock double action type for european cylinder.
Recommended for doors with high use /

Cerradura de embutir de vaivén para bombillo europeo.
Indicada para puertas con uso elevado.

Material: EN 1.4301
Satinado / Satin / Satin



Chapa testa standard/
Standard strike plate /
Cerradero estandar



IN.20.894.C5
Chapa testa opcional/
Strike plate opcional/
Cerradero opcional.



OPCIONAL/OPTIONAL

IN.20.AKN
Adaptador para chave normal.

Adapter for normal key.
Adaptador para llave normal.



OPCIONAL/OPTIONAL

IN.20.AWC
Converter para fechadura de casa de banho.

Converter for toilet lock.
Convertor para cerradura de de condeña .

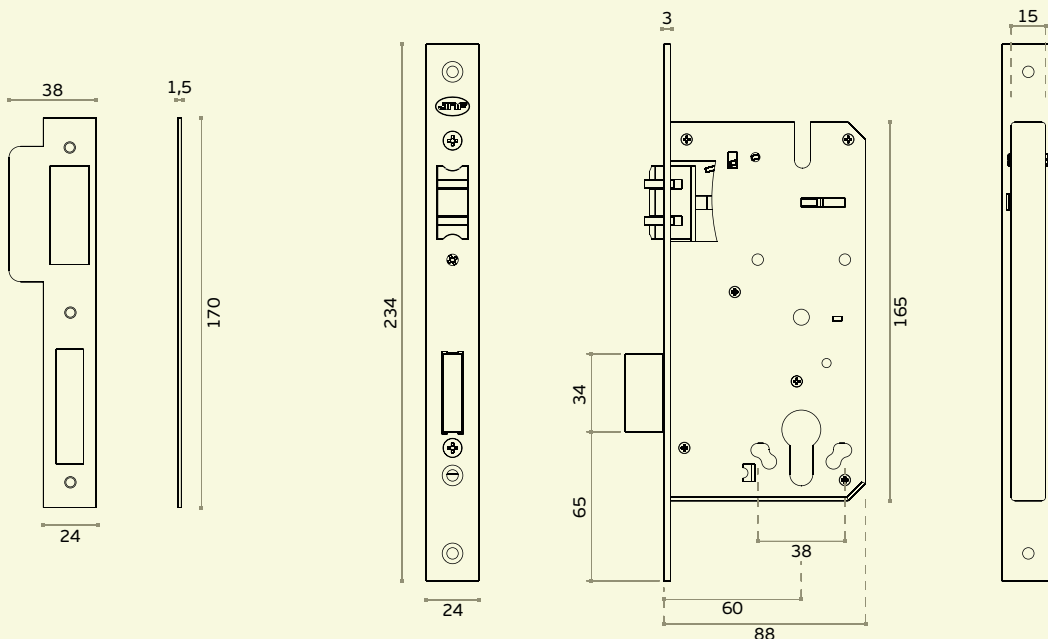

SÉRIE 780 - FECHADURAS ANTI-PÂNICO /

780 SERIES - ANTIPANIC LOCKS /

SERIE 780 - CERRADURAS ANTIPÁNICO

A fechadura IN.20.789 da JNF foi criada para ser utilizada em portas que estão sujeitas a uma utilização elevada. Fechadura anti-pânico e automática. Quando a porta é fechada, o trinco e língua fecham automaticamente.

JNF's IN.20.789 lock was created to be applied in doors that have high use. Automatic and antipanic lock. When the door is closed, the strike and the bolt close automatically.

La cerradura IN.20.789 de JNF fue creada para ser aplicada en puertas que se utilizan de un modo elevado. Cerradura antipánico y automática. Cuando las puertas se cierra, el picaporte y pestillo, se cierran automáticamente.

500 Mil
cycles

Quadra em aço temperado/
Handle square hole made in hardened steel/
Nueca en acero templado.

Furação para fixação do puxador /
Handle fixing holes /
Agujeros para tornillos pasantes.

**Fechadura de fecho automático, sem
necessidade de rodar a chave /**
The lock closes automaticly, without
having to turn the key/
Cierre automatico, la cerradura se bloquea
automaticamente sin la llave.

Caixa fechada/
Closed lock case /
Caja cerrada.

**Trinco reversível em aço inox
EN 1.4301/**
Adjustable latch made in stainless steel
EN 1.4301/
Picaporte reversible en acero inox EN
1.4301.

**Chapa testa reversível
e ajustável /**
Adjustable and
reversible strike plate /
Cerradero ajustable y
reversible.

Língua em aço temperado/
Dead bolt made in hardened steel /
Pestillo en acero templado.

Frente em Aço Inox EN 1.4301/
Front plate made in Stainless steel EN 1.4301 /
Frente en Acero inox EN 1.4301.



Fechadura anti-pânico e automática.
Quando a porta é fechada, o trinco e a língua fecham automaticamente.

Automatic and antipanic lock.
When the door is closed, the strike and the bolt close automatically.

Cerradura antipánico y automática.
Cuando las puertas se cierra, el picaporte y pestillo, se cierran automáticamente.

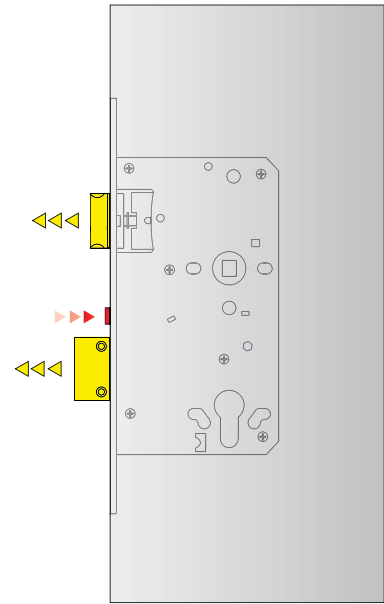
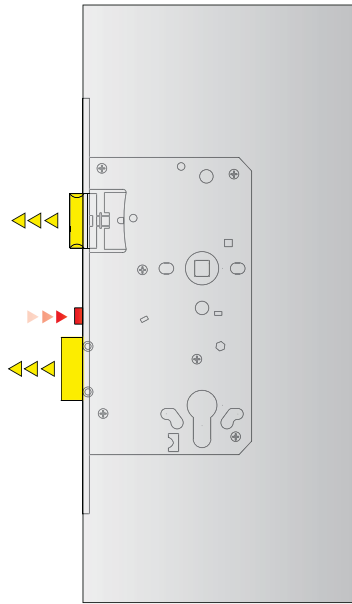
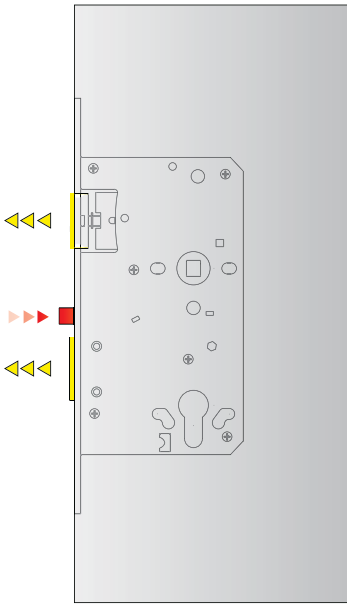

Ao abrir a porta pelo interior com o puxador, ou pelo exterior com o cilindro, recolhe o trinco e a língua em simultâneo.

When the door is open from the inside by the handle, or from the outside by the cylinder, both strike and bolt collect.

Quando la puerta es abierta por el interior con la manilla, o por el exterior con el bombillo, recoge el pestillo y picaporte al mismo tiempo.

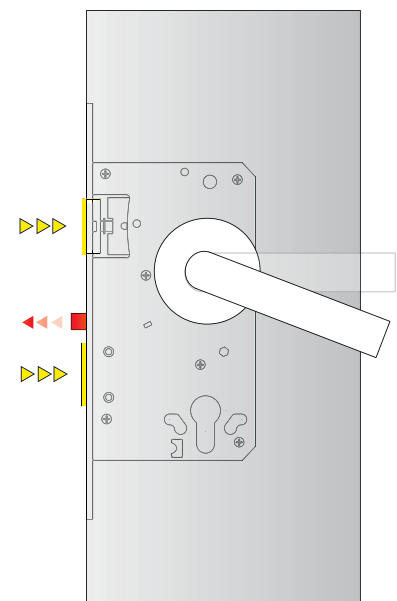
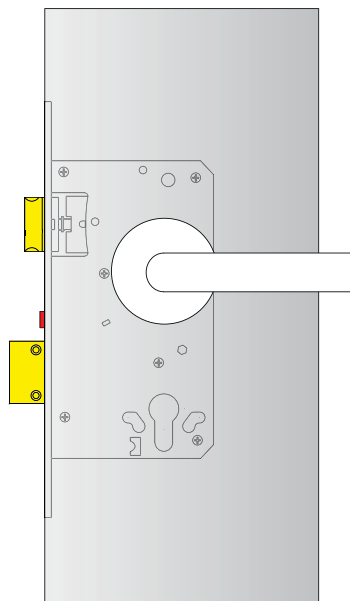
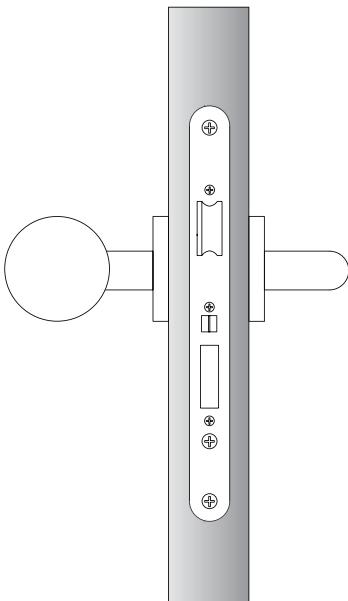

SÉRIE 780 - FECHADURAS ANTI-PÂNICO /

780 SERIES - ANTIPANIC LOCKS /

SERIE 780 - CERRADURAS ANTIPÁNICO

IN.20.789

Fechadura de embutir para cilindro europeu.
Abertura através do puxador pelo interior,
com sistema anti-pânico, ou através da chave
pelo exterior. Indicada para portas com uso
elevado /

Mortise door lock for european cylinder.
 Anti-panic mechanism, the lock can be opened
 through the lever handle from the inside, or with
 key from the outside.
 Recommended for doors with heavy use /

Cerradura de embutir para bombillo europeo.
 Función anti-panico por el interior o por bombillo
 por el exterior, la cerradura se abre mediante
 accionamiento de la manilla.
 Indicada para puertas con uso elevado.

Material: EN 1.4301

Satinado / Satin / Satin

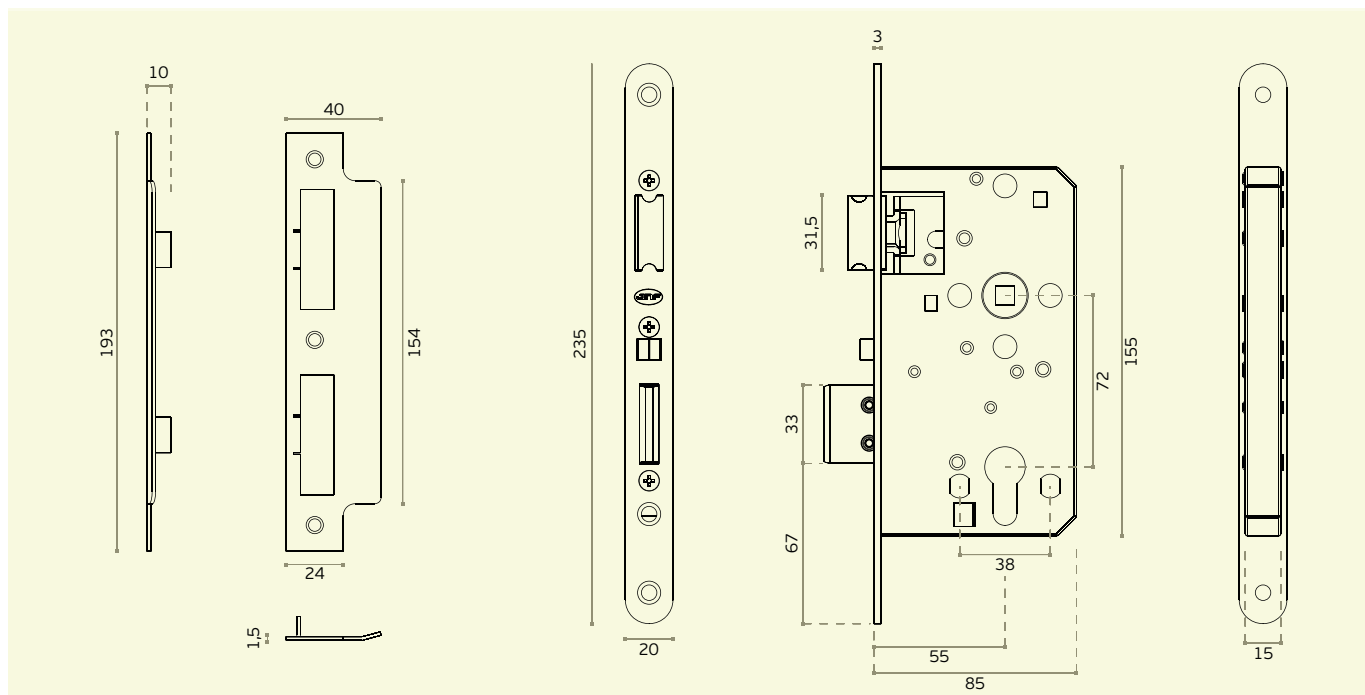
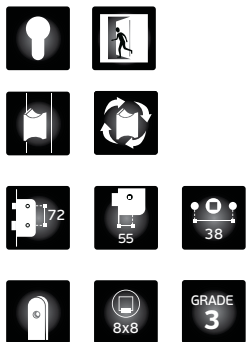

SÉRIE 790 / 790 SERIES / SERIE 790.

IN.20.792 IN.20.792.R

Fechadura de embutir para cilindro europeu.
Indicada para portas com uso médio /

Mortise door lock for european cylinder.
Recommended for doors with medium use /

Cerradura de embutir para bombillo europeo.
Indicada para puertas con uso mediano.

Material: EN 1.4301
Satinado / Satin / Satin

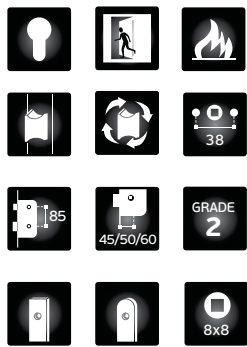

FIRE TEST EVIDENCE



IN.20.792
Cantos rectos /
Straight corners /
Cantos rectos.

IN.20.792.R
Cantos redondos /
Rounded corners /
Cantos redondos.

OPCIONAL/OPTIONAL

IN.20.AKN
Adaptador para chave normal.

Adapter for normal key.
Adaptador para llave normal.



OPCIONAL/OPTIONAL

IN.20.AWC
Converter para fechadura de casa de banho.

Converter for toilet lock.
Converter para cerradura de de condeña .

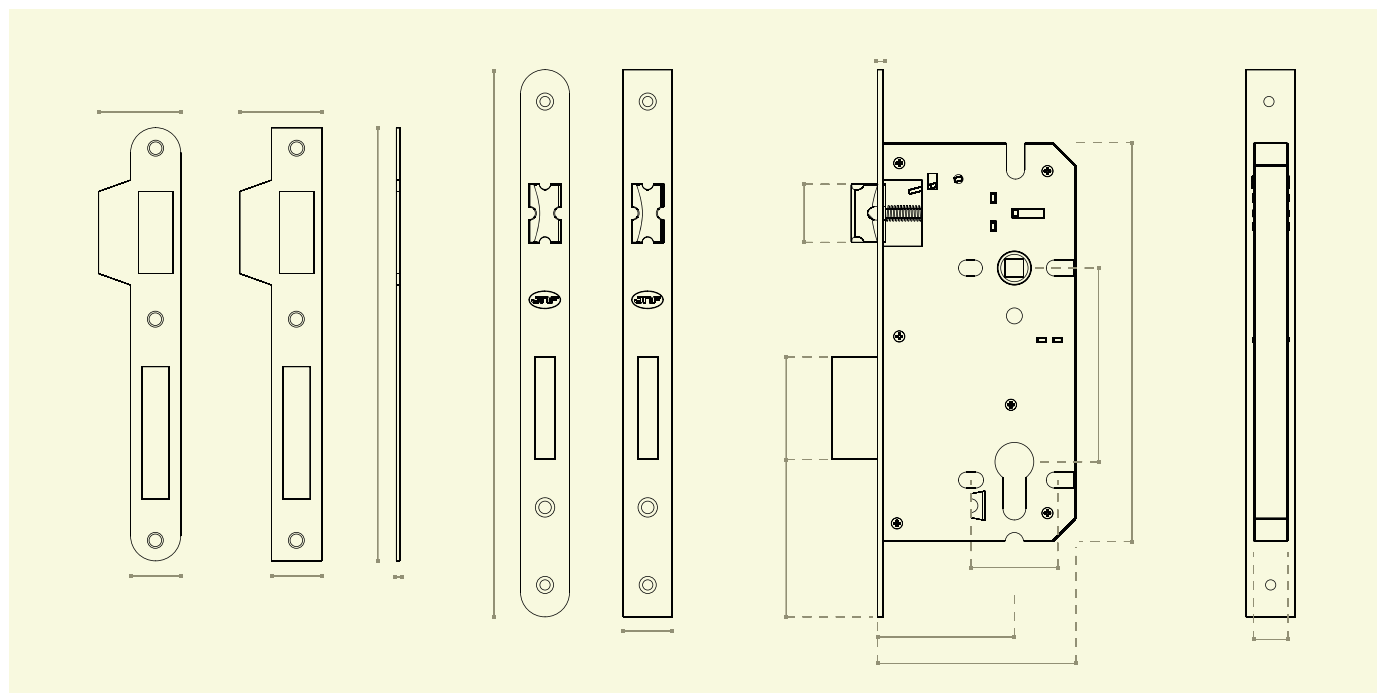

SÉRIE 800 - MAGNÉTICA / 800 SERIE - MAGNETIC / SERIE 800 - MAGNETICA

Fechaduras desenvolvidas para a indústria de portas, permitindo mecanizar todas as folhas com a mesma medida, a escolha da fechadura pode ser efectuada na obra. O sistema de trinco magnético permite um funcionamento silencioso e suave garantindo uma resistência e aspecto semelhante a uma fechadura tradicional.

This locks was developed to the door industry. All the doors can be drilled with the same hole box. The lock can be chose at the building. The magnetic latch system allows a silent and smooth operation and at the same time ensures a similar look to a traditional lock.

Série desarrollada para la industria de puertas. El cajeado es identico en todas las referencias. La cerradura puede ser elejida en obra. El sistema de cierre magnético permite un funcionamiento silencioso y suave garantizando un bueno funcionamiento y un aspecto similar a una cerradura tradicional.

Quadra com mola interior para eliminação da folga entre o puxador e quadra / Handle square hole with an internal spring to avoid any break between the Spindle and the lock / Nueca en acero inox con muelle interior para eliminar la holgura entre la manilla y la nueca.

Furação para fixação do puxador / Handle fixing holes / Agujeros para tornillos pasantes.

Caixa fechada / Closed lock case / Caja cerrada.



Trinco magnético metálico / Metallic magnetic latch / Picaporte magnético metálico.



Chapa testa ajustável e reversível / Adjustable and reversible strike plate / Cerradero regulable e reversible.

Fecho em aço inoxidável / Stainless steel dead bolt / Pestillo de acero inox.

Frente amovível / Replaceble front plate Frontal sustituible

1 - Quando a porta se encontra aberta o trinco magnético mantém-se no interior da fechadura, ficando apenas visível a frente da fechadura sem qualquer saliência.

2 - Quando se fecha a porta e se alinham a fechadura e a respectiva testas, uma força magnética atrai o fecho, bloqueando a porta de forma silenciosa e precisa, evitando o habitual ruído provocado pelo trinco mecânico a bater e deslizar na testas da fechadura.

1 - When the door is open the magnetic latch remains inside the lock, leaving only visible the front of the lock without any salience.

2 - When we close the door and align the lock and its strike plate, a magnetic force attracts the latch, blocking the door quietly and precisely, avoiding the usual noise caused by mechanical latch hitting and sliding on the head of the strike plate.

1 - Cuando la puerta se encuentra abierta el cierre magnético permanece dentro de la cerradura, dejando visible el frontal de la cerradura sin ningún tipo de saliente.

2 - Al cerrar la puerta se alinea la cerradura y su cerradero, una fuerza magnética atrae el picaporte, bloqueando la puerta de una forma silenciosa y precisa, evitando el ruido habitual causada por picaporte mecánico al golpear en el cerradero.

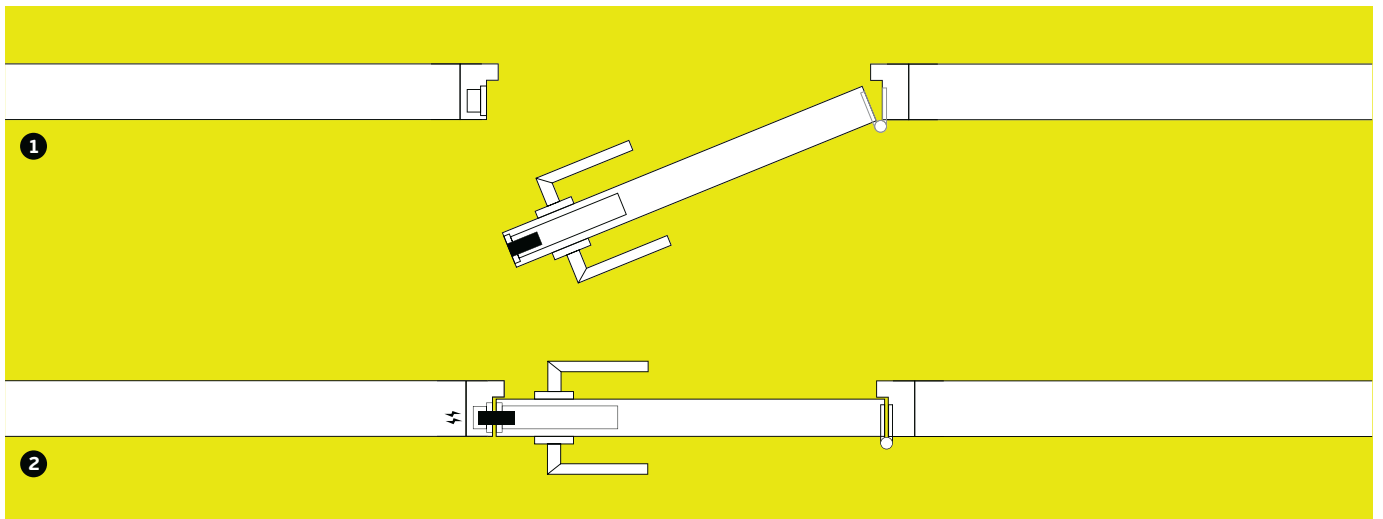

MAGNETIC
security lock

SÉRIE MAGNÉTICA / MAGNETIC SERIE / SERIE MAGNETICA



IN.20.805

Fechadura de embutir magnética para cilindro Europeu. Indicada para portas com uso médio /

Magnetic mortise door lock for European cylinder. Recommended for doors with medium use /

Cerradura de embutir magnetica para bombillo Europeu. Indicada para puertas con uso mediano.

Material: EN 1.4301
Satinado / Satin / Satin

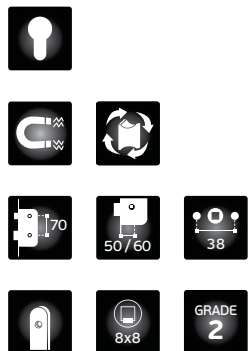

OPCIONAL/OPTIONAL

IN.20.AKN Adaptador para chave normal.

Adapter for normal key.
Adaptador para llave normal.



IN.20.AWC Adaptador para fecho WC / Adaptador para condena de baño.

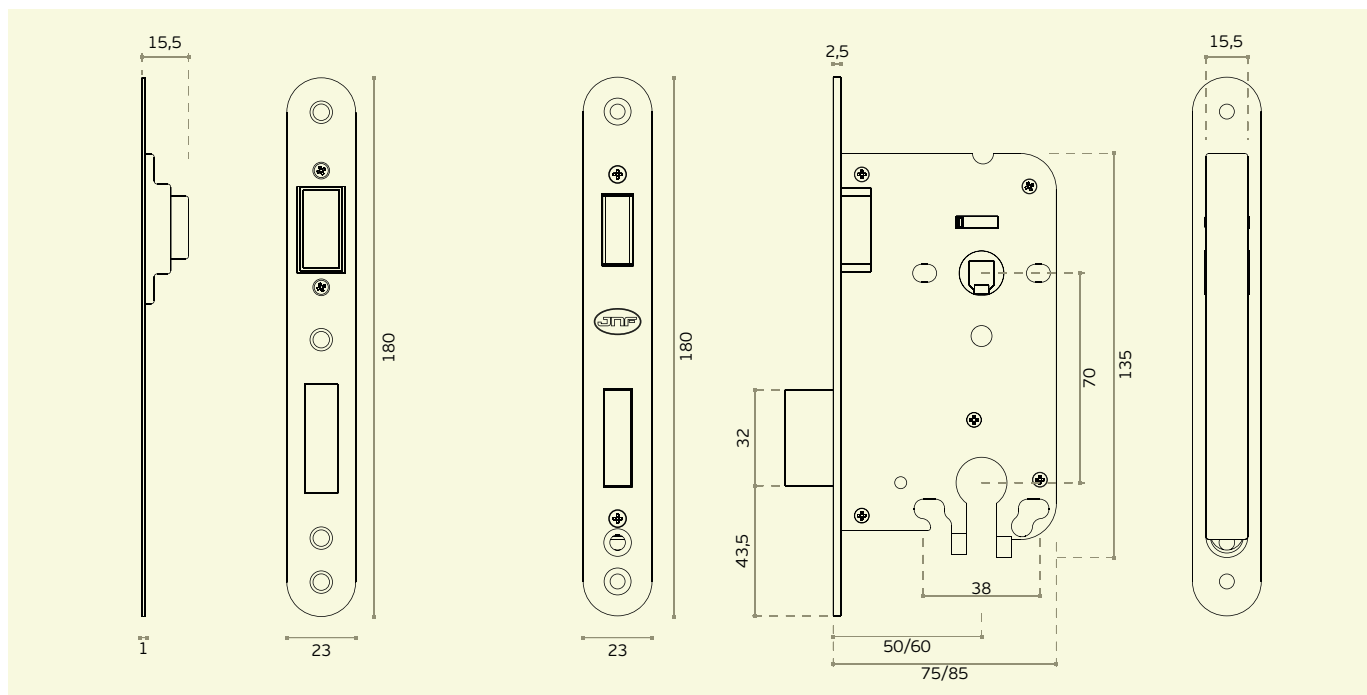



IN.20.808

**Fechadura de embutir magnética de passagem.
Indicada para portas de entrada ou interior
com uso médio /**

Magnetic mortise door lock passage type.
Recommended for entrance doors
with medium use /

Cerradura de embutir magnetica de passo.
Indicada para puertas de entrada con uso mediano. /

Material: EN 1.4301
Satinado / Satin / Satin



PASSAGEM
PASSAGE
PASO



15,5

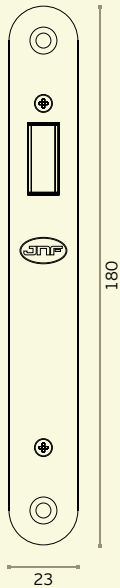
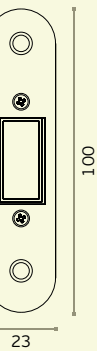

2,5

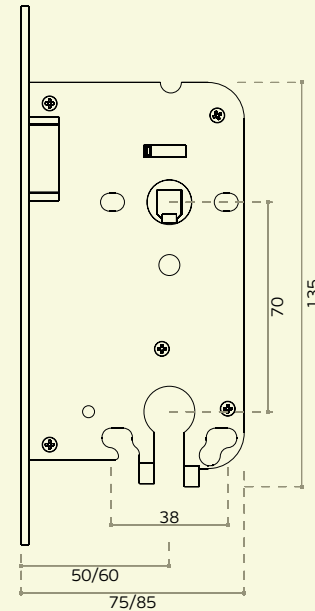

15,5

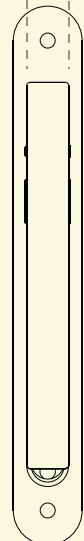

SÉRIE FREELINE - MAGNÉTICA / FREELINE SERIE - MAGNETIC / SERIE FREELINE - MAGNETICA

FREELINE

Fechaduras desenvolvidas para a indústria de portas, permitindo mecanizar todas as folhas com a mesma medida, a escolha da fechadura pode ser efectuada na obra. O sistema de trinco magnético permite um funcionamento silencioso e suave garantindo uma resistência e aspecto semelhante a uma fechadura tradicional.

This locks was developed to the door industry. All the doors can be drilled with the same hole box. The lock can be chose at the building. The magnetic latch system allows a silent and smooth operation and at the same time ensures a similar look to a traditional lock.

Série desarrollada para la industria de puertas. El cajeado es identico en todas las referencias. La cerradura puede ser elejida en obra. El sistema de cierre magnético permite un funcionamiento silencioso y suave garantizando un bueno funcionamiento y un aspecto similar a una cerradura tradicional.

Trinco magnético /
Magnetic latch /
Picaporte magnético.



Quadra 8x8 com limitação de curso /
8x8 follower with path limitation /
Nueca 8x8 con limitación de curso.

Furação para fixação do puxador /
Handle fixing holes /
Agujeros para tornillos pasantes.

Frente com 18mm /
18mm front plate
Frontal con 18mm

Chapa testa reversível /
Reversible strike plate /
Cerradero reversible.

Caixa fechada /
Closed lock case /
Caja cerrada.

FREELINE RANGE



NEW

IN.20.835

Fechadura de embutir magnética para cilindro Europeu.
Indicada para portas com uso médio /

Magnetic mortise door lock for European cylinder.
Recommended for doors with medium use /

Cerradura de embutir magnetica para bombillo Europeu.
Indicada para puertas con uso mediano.

FREELINE



OPCIONAL/OPTIONAL

IN.20.AKN

Adaptador para chave normal.

Adapter for normal key.
Adaptador para llave normal.



IN.20.AWC

Adaptador para fecho WC /
Adapter for snib indicator /
Adaptador para condena de baño.

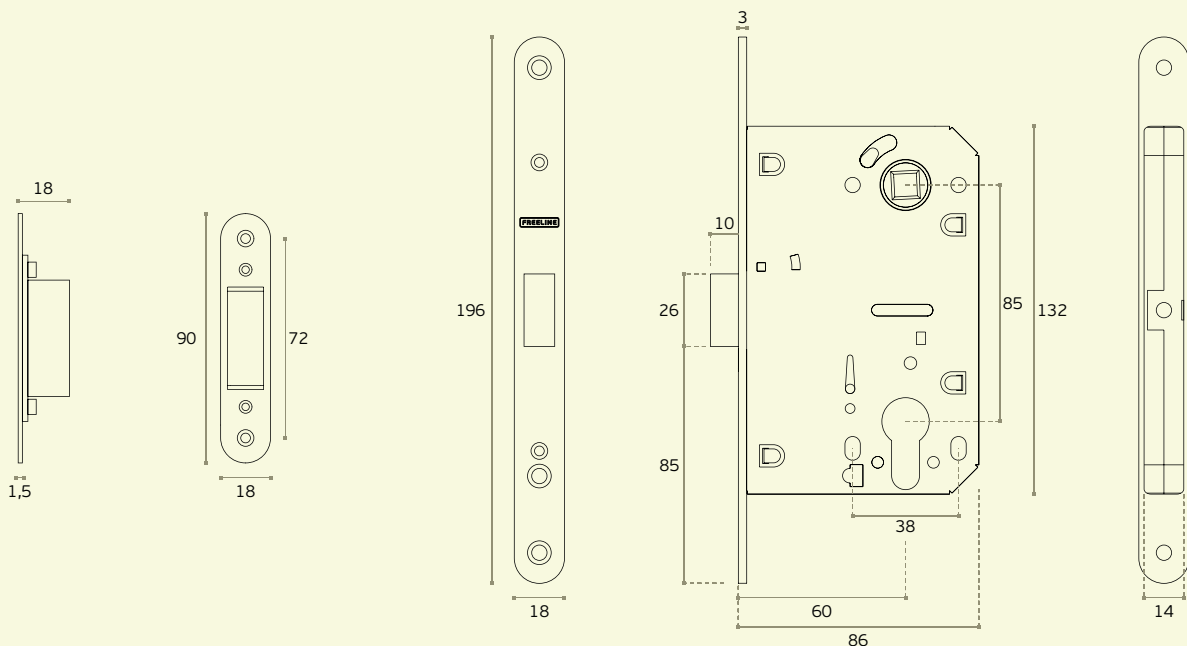

FREELINE RANGE



NEW

IN.20.836

Fechadura de embutir para casa de banho.
Indicada para portas com uso médio /

Mortise door lock for bathroom use.
Recommended for doors with medium use /

Cerradura de embutir para baño.
Indicada para puertas con uso mediano.



FREELINE

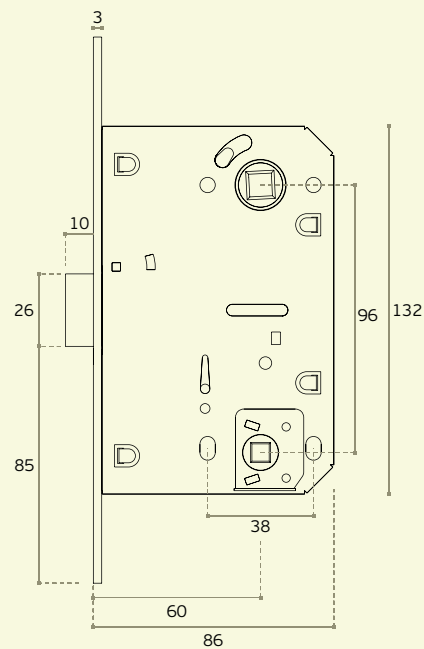
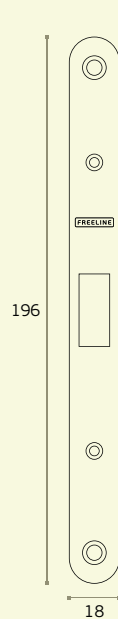
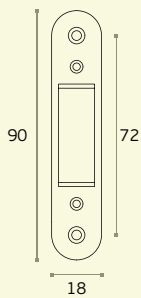
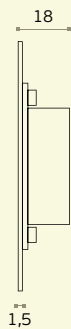



IN.20.153

Trinco magnético silencioso /
Adjustable magnetic silent latch. /
Picaporte magnetico reversible silencioso.

Material: EN 1.4301
Satinado / Satin / Satin

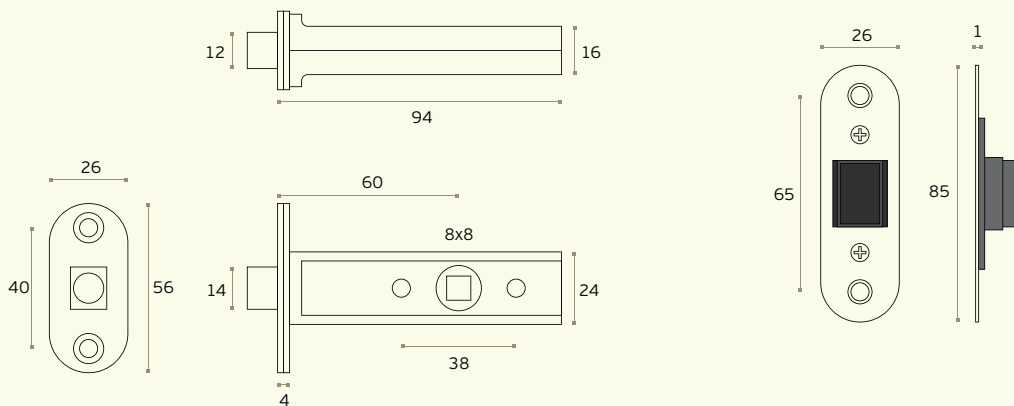
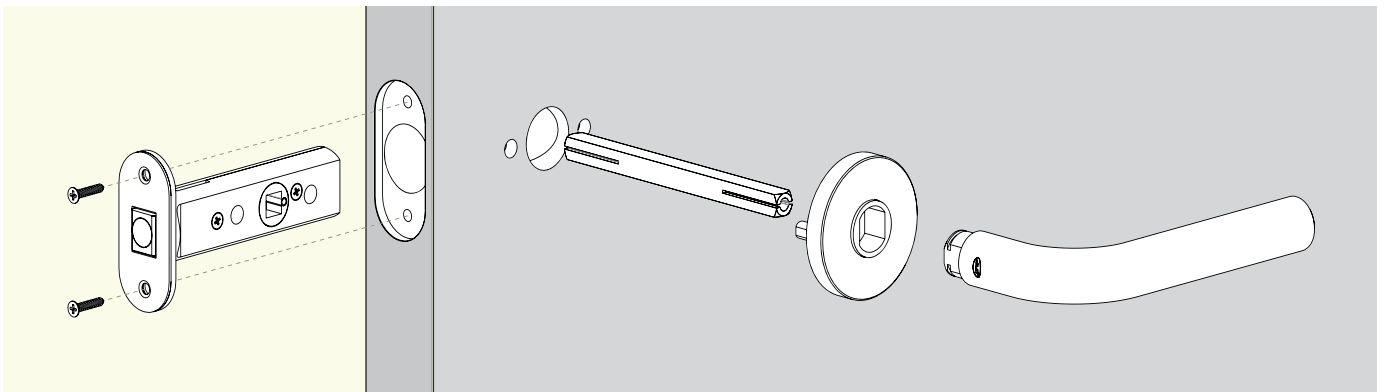
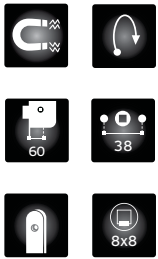

SÉRIE 820 COM CAIXA UNIFICADA / 820 SERIES WITH UNIFIED CASE / SERIE 820 CON CAJA UNIFICADA.

Fechaduras desenvolvidas para a indústria de portas, permitindo mecanizar todas as folhas com a mesma medida, a escolha da fechadura pode ser efectuada na obra.

This locks was developed to the door industry. All the doors can be drilled with the same hole box. The lock can be chose at the building.

Série desarrollada para la industria de puertas. El cajeado es identico en todas las referencias. La cerradura puede ser elejida en obra.

Quadra com mola interior para eliminação da folga entre o puxador e quadra / Handle square hole with a internal spring to avoid any break between the Spindle and the lock / Nueca en acero inox con muelle interior para eliminar la holgura entre la manilla y nueca.

Furação para fixação do puxador / Handle fixing holes /
Agujeros para tornillos pasantes.

Caixa fechada /
Closed lock case /
Caja cerrada.



Placa frontal de 23 mm em aço inox EN 1.4301 / Front plate of 23 mm in stainless steel EN 1.4301 / Placa frontal de 23 mm de acero inoxidable EN 1.4301.

Trinco silencioso reversível com silenciador intermédio em Nylon / Reversible silent latch with noise free nylon insert / Picaporte silencioso reversible con silenciador en nylon.

Chapa testa ajustável e reversível / Adjustable and reversible strike plate / Cerradero regulable y reversible.

Frente amovível /
Replaceble front plate /
Frontal sustituible.



IN.20.825
IN.20.825.R

Fechadura de embutir para cilindro europeu. Indicada para portas com uso médio /

Mortise door lock for european cylinder. Recommended for doors with medium use /

Cerradura de embutir para bombillo europeo. Indicada para puertas con uso mediano.

Material: EN 1.4301
Satinado / Satin / Satin

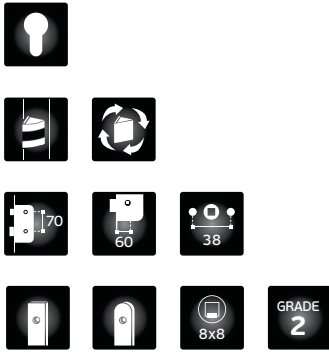

IN.20.825
Cantos rectos /
Straight corners /
Cantos rectos.

IN.20.825.R
Cantos redondos /
Rounded corners /
Cantos redondos.

OPCIONAL/OPTIONAL

IN.20.AKN
Adaptador para chave normal.

Adapter for normal key. Adaptador para llave normal.



IN.20.AWC
Adaptador para fecho WC /
Adapter for snib indicator /
Adaptador para condena de baño.

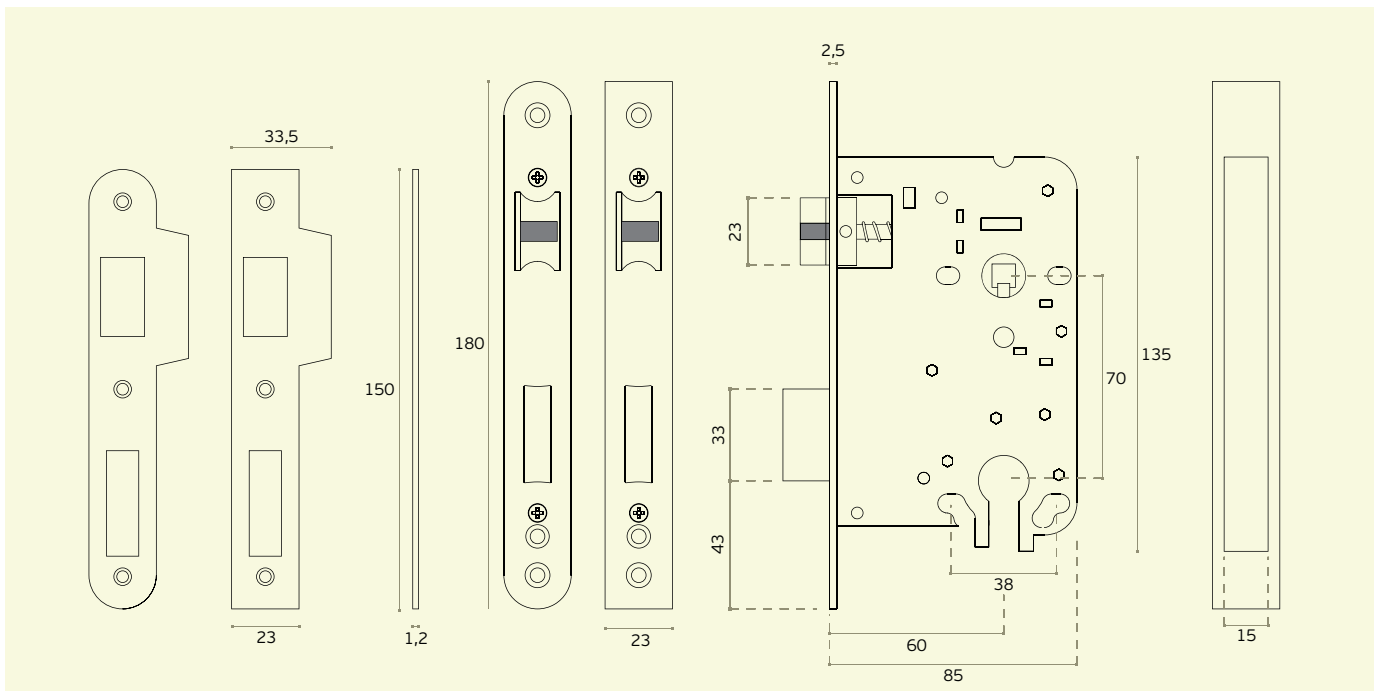

SÉRIE 820 COM CAIXA UNIFICADA /

820 SERIES WITH UNIFIED CASE /

SERIE 820 CON CAJA UNIFICADA.

IN.20.827**IN.20.827.R**

Fechadura de embutir para casa de banho.
Indicada para portas com uso médio /

Mortise door lock for bathroom use.
Recommended for doors with medium use /

Cerradura de embutir para baño.
Indicada para puertas con uso mediano.

Material: EN 1.4301
Satinado / Satin / Satin



IN.20.827
Cantos rectos /
Straight corners /
Cantos rectos.

IN.20.827.R
Cantos redondos /
Rounded corners /
Cantos redondos.

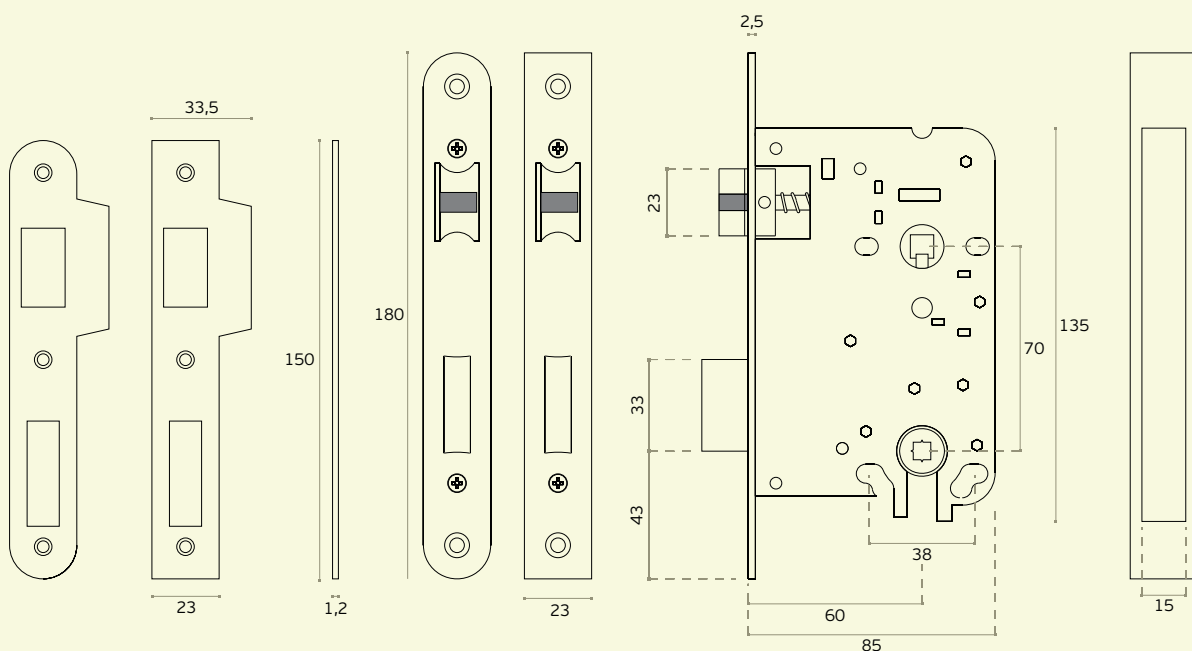

IN.20.936
IN.20.936.R

Fechadura de embutir com chave normal.
Indicada para portas com uso médio /

Mortise door lock with normal key.
Recommended for doors with medium use /

Cerradura de embutir llave normal.
Indicada para puertas con uso mediano.

Material: EN 1.4301
Satinado / Satin / Satin

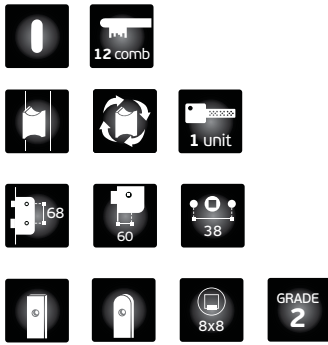

IN.20.936
Cantos rectos /
Straight corners /
Cantos rectos.

IN.20.936.R
Cantos redondos /
Rounded corners /
Cantos redondos.

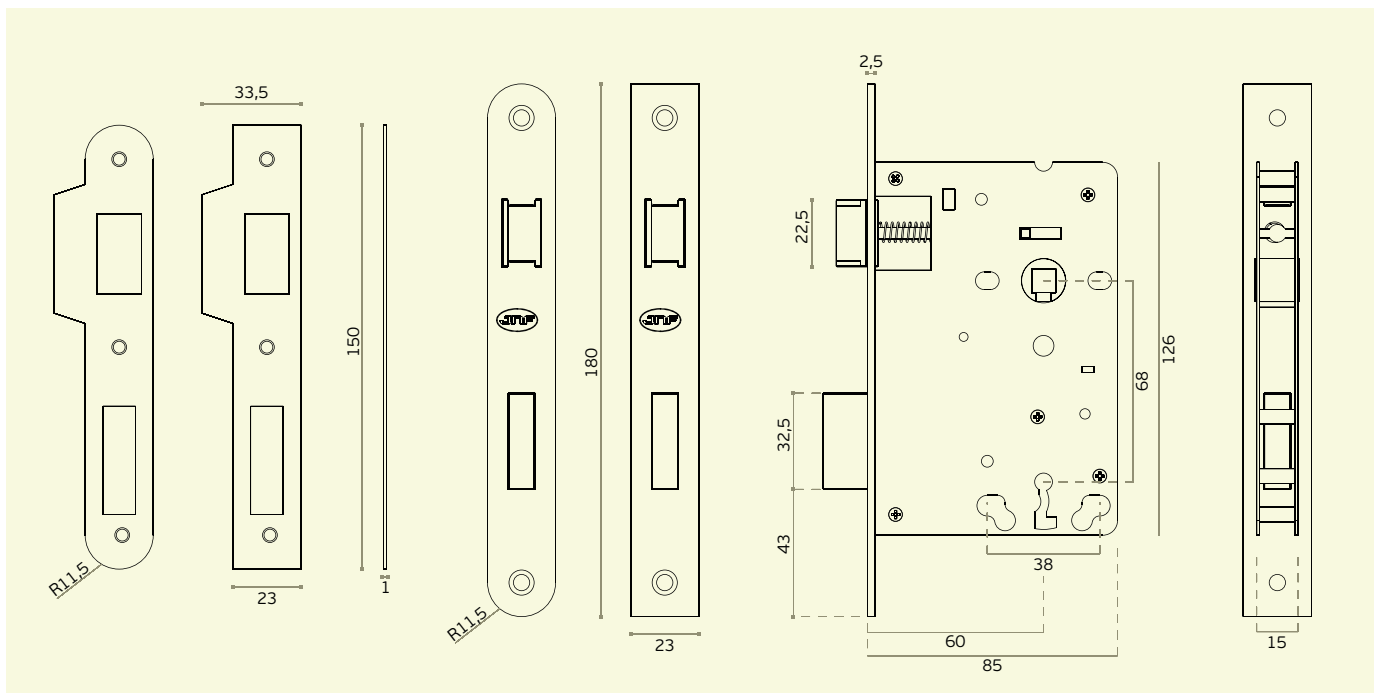

SÉRIE 910 / 910 SERIES / SERIE 910.

IN.20.916

Fechadura de embutir com chave normal .
Indicada para portas com uso médio /

Mortise door lock with normal key.
Recommended for doors with medium use /

Cerradura de embutir con llave normal.
Indicada para puertas con uso mediano.

Material: EN 1.4301
Satinado / Satin / Satin

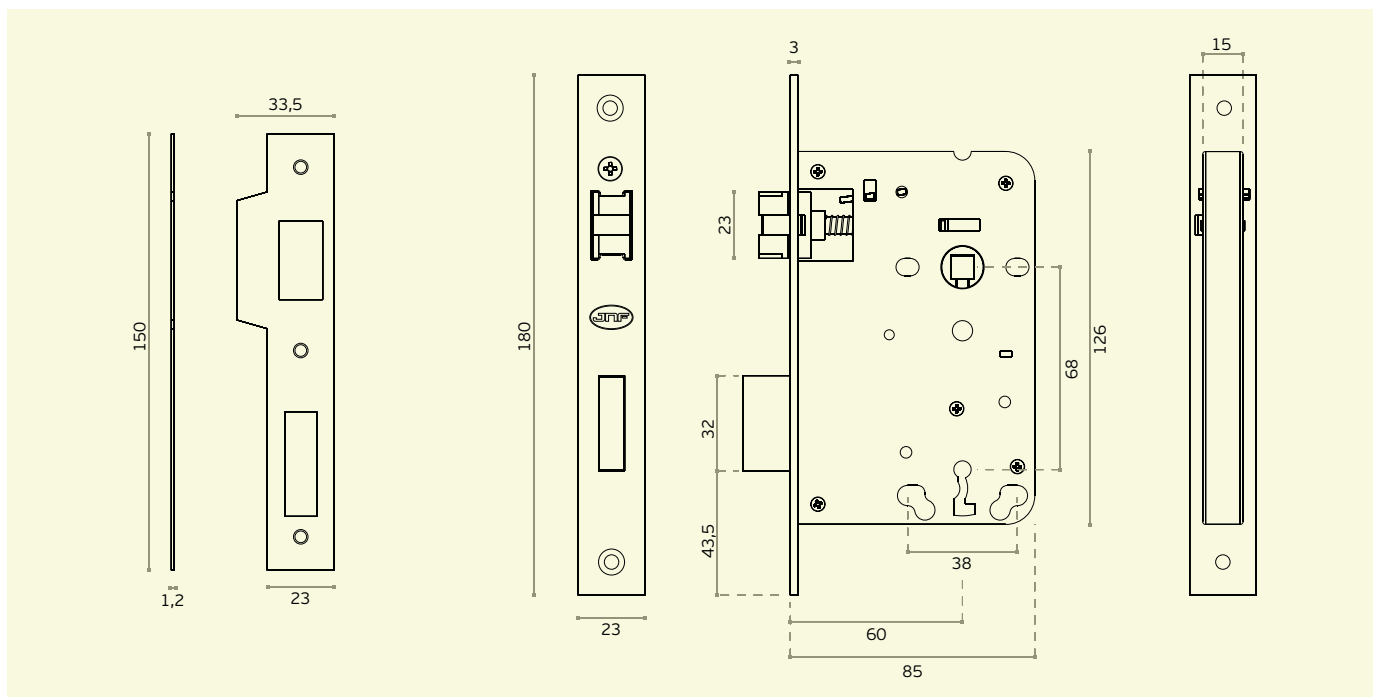

IN.20.917

Fechadura de embutir para casa de banho.
Indicada para portas com uso médio /

Mortise door lock for bathroom use.
Recommended for doors with medium use /

Cerradura de embutir para baño.
Indicada para puertas con uso mediano.

Material: EN 1.4301
Satinado / Satin / Satin

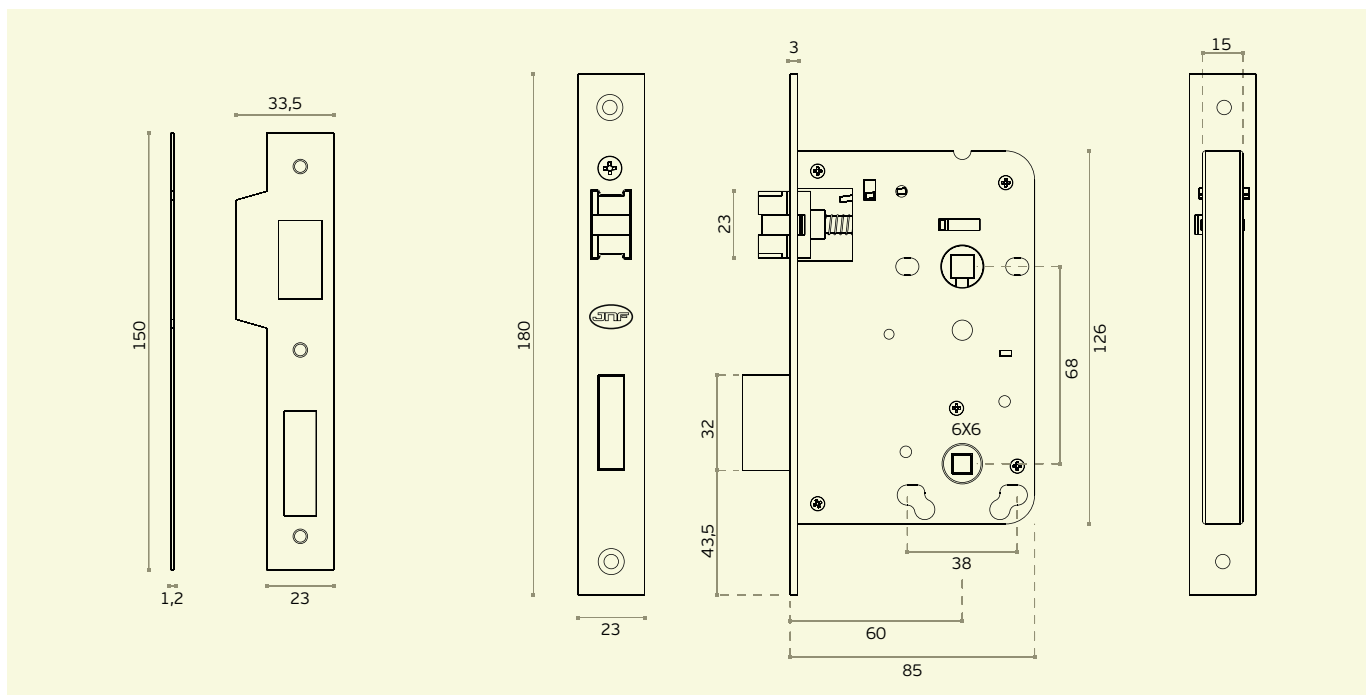
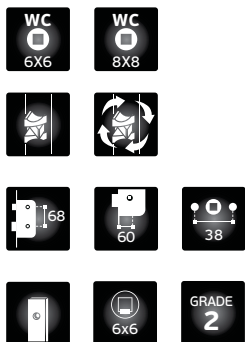

SÉRIE 700 / 700 SERIES / SERIE 700.

A Série 700 da JNF foi criada para ser utilizada em portas interiores que estão sujeitas a uma utilização ligeira.

JNF's 700 Series was created to be applied in interior doors that have a light use.

La serie 700 de JNF fue creada para ser aplicada en puertas interiores que se utilizan de un modo ligero.

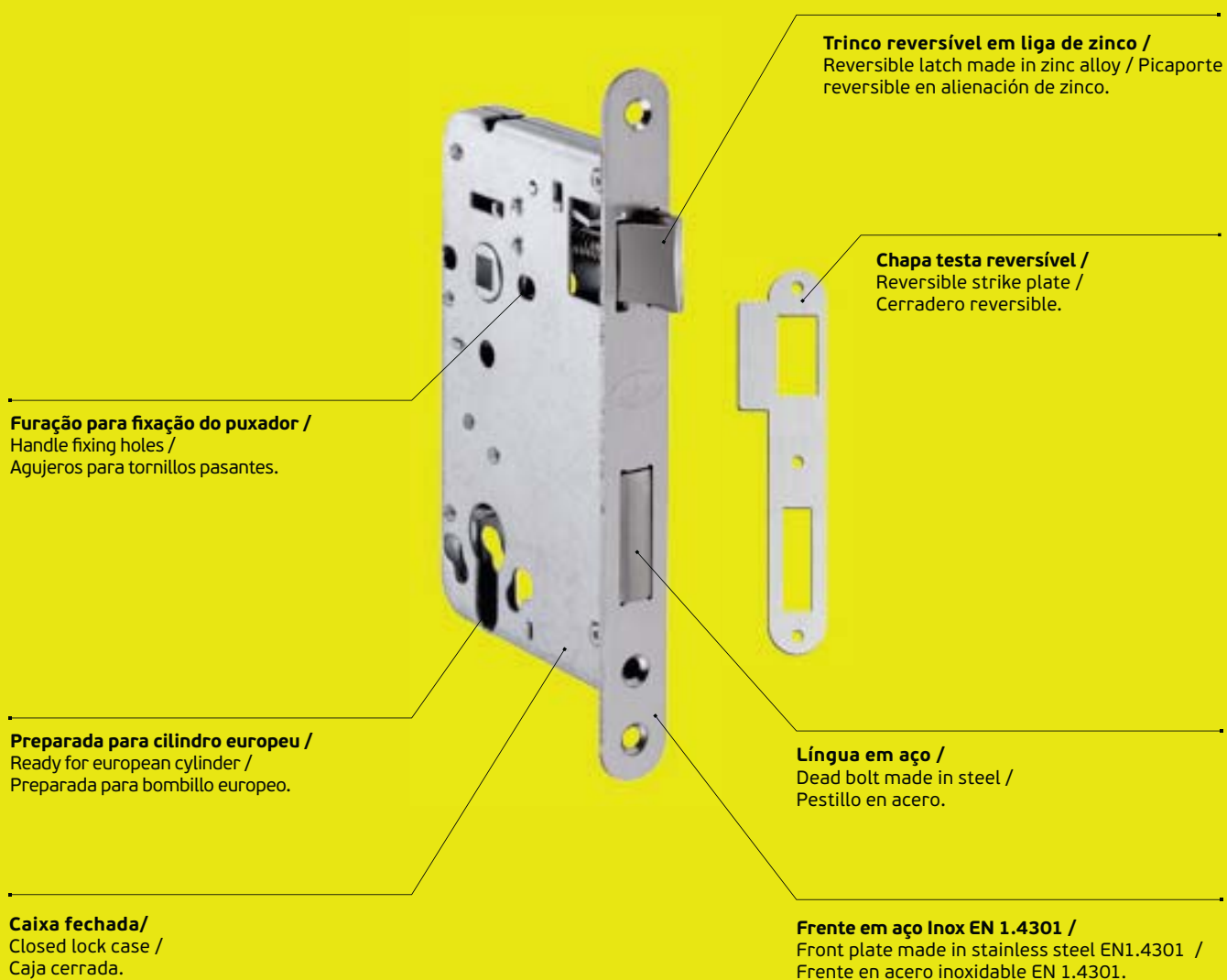

IN.20.703

**Fechadura de embutir para cilindro europeu.
Indicada para portas com uso ligeiro /**

Mortise door lock for european cylinder.
Recommended for doors with light use /

Cerradura de embutir para bombillo europeo.
Indicada para puertas con uso ligero.

**Material: Aço Inox/
Stainless steel/ Acero inoxidable
Satinado / Satin / Satin**

NEW

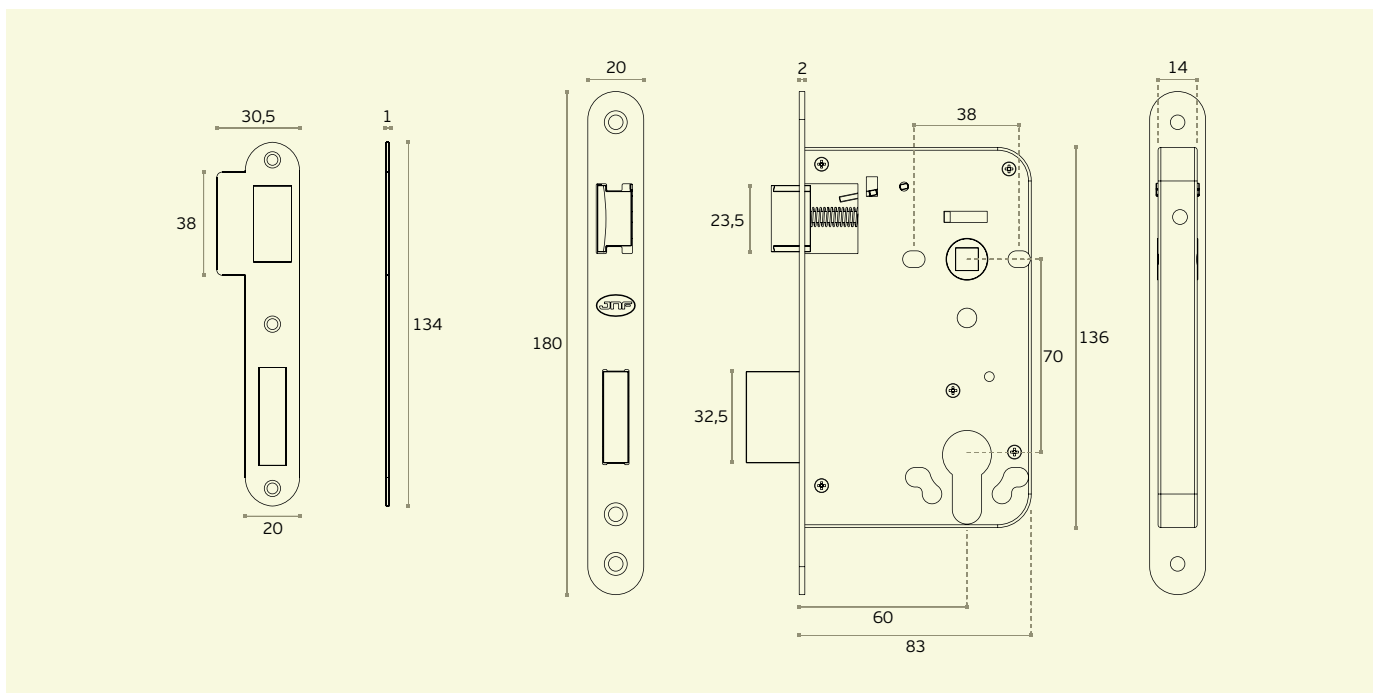
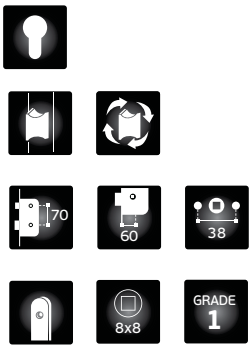

SÉRIE 700 / 700 SERIES / SERIE 700.

IN.20.705

**Fechadura de embutir com chave normal.
Indicada para portas com uso ligeiro /**

Mortise door lock with normal key.
Recommended for doors with light use /

Cerradura de embutir llave normal.
Indicada para puertas con uso ligero.

Material: Aço Inox /
Stainless steel / Acero inoxidable
Satinado / Satin / Satin

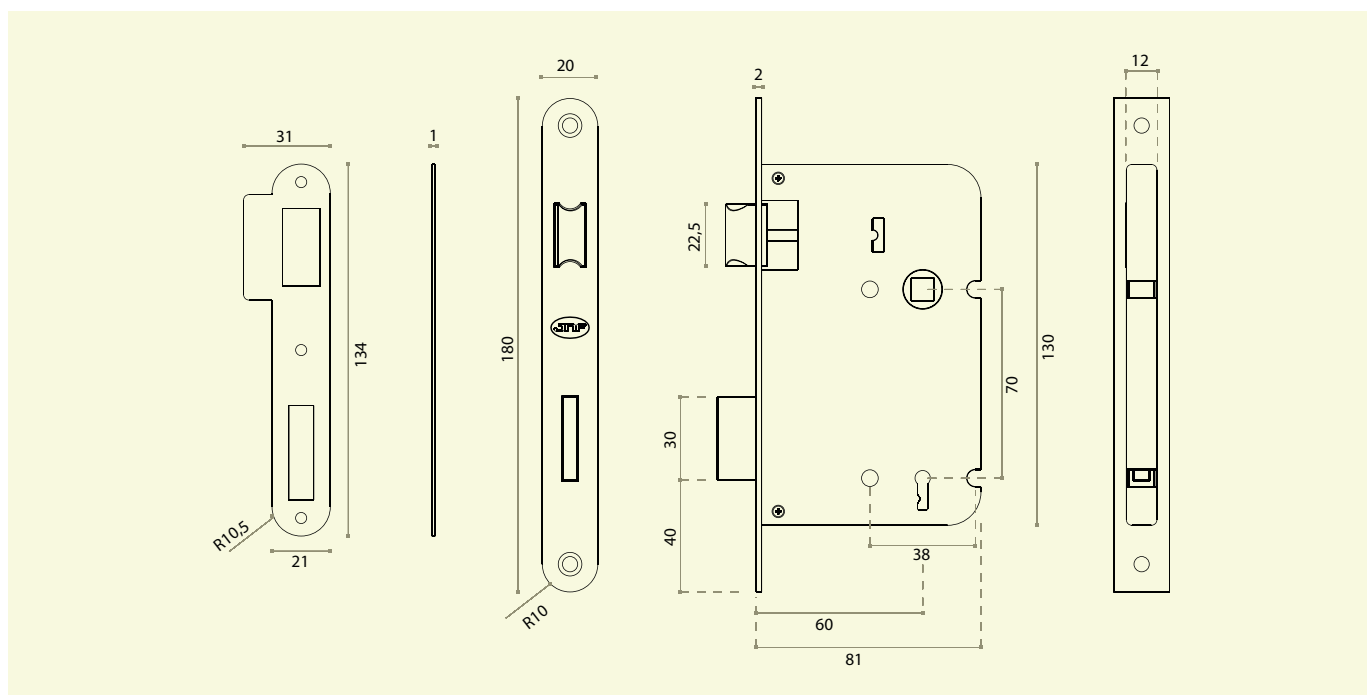
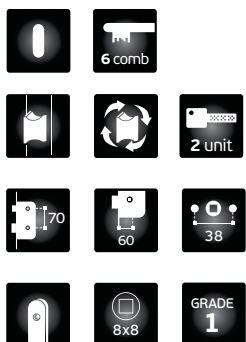

IN.20.706

Fechadura de embutir para casa de banho.
Indicada para portas com uso ligeiro /

Mortise door lock for bathroom use.
Recommended for doors with light use /

Cerradura de embutir para baño.
Indicada para puertas con uso ligero.

Material: Aço Inox/
Stainless steel/ Acero inoxidable
Satinado / Satin / Satin

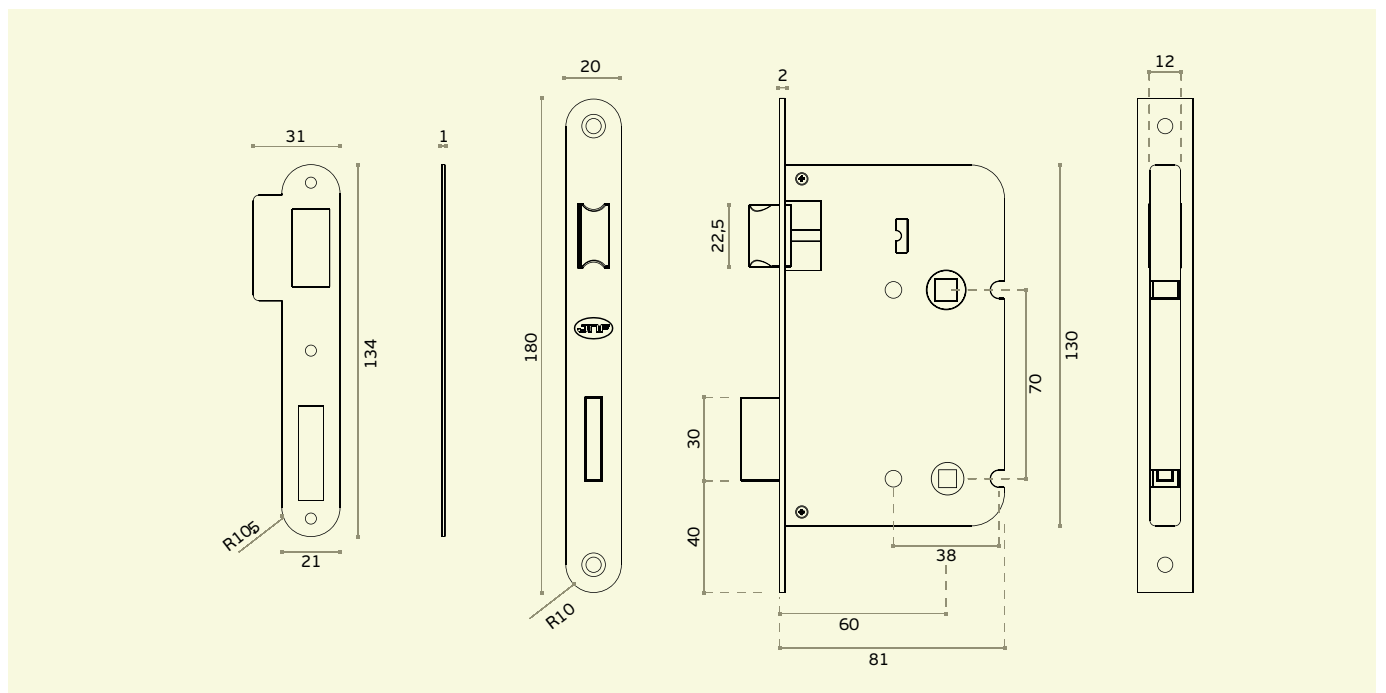

SÉRIE 700 / 700 SERIES / SERIE 700.

IN.20.716

IN.20.716.R

Fechadura de embutir com chave normal.
Indicada para portas com uso ligeiro /

Mortise door lock with normal key.
Recommended for doors with light use /

Cerradura de embutir llave normal.
Indicada para puertas con uso ligero.

Material: Aço Inox /
Stainless steel / Acero inoxidable
Satinado / Satin / Satin



IN.20.716
Cantos rectos /
Straight corners /
Cantos rectos.

IN.20.716.R
Cantos redondos /
Rounded corners /
Cantos redondos.

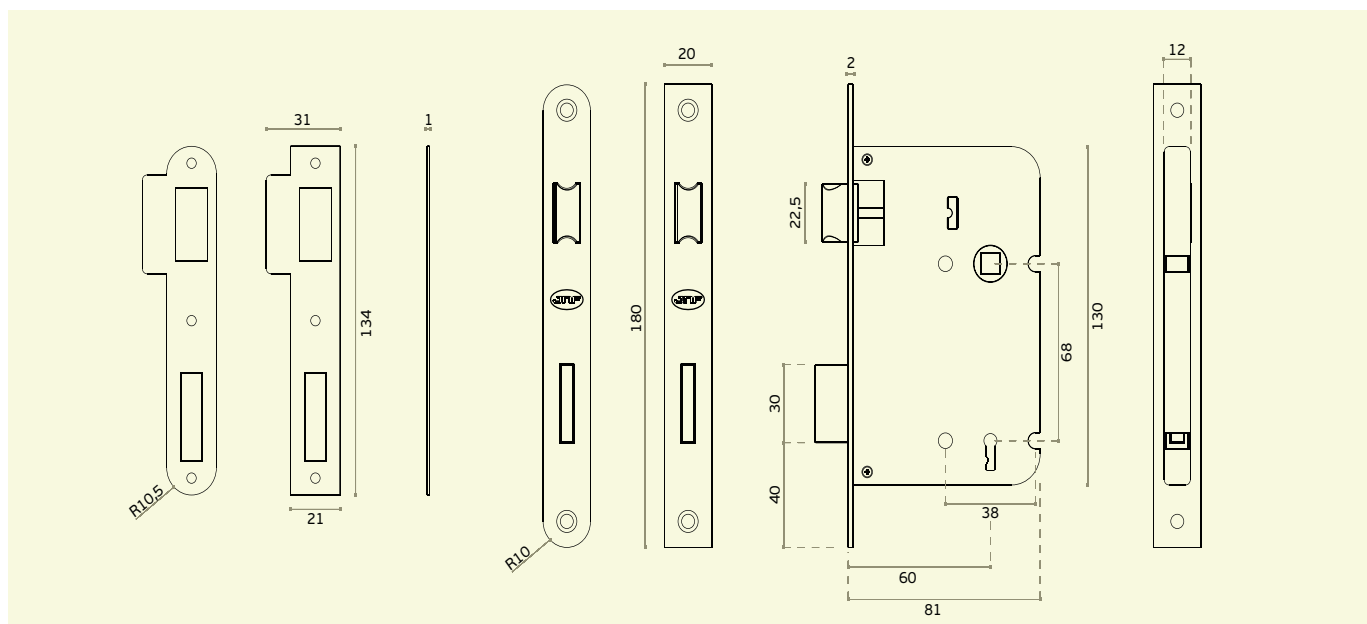
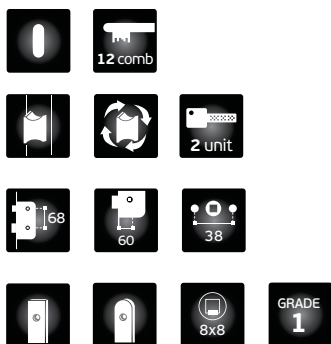

FECHADURAS AUXILIARES E TRINCOS / AUXILIARY LOCKS AND LATCHES / CERRADURAS Y CERROJOS AUXILIARES.

IN.20.630

Fechadura de serviço com chave de cruz /
Lock service with cross key /
Cerradura de servicio con llave de cruz

Material: EN 1.4301
Satinado / Satin / Satin

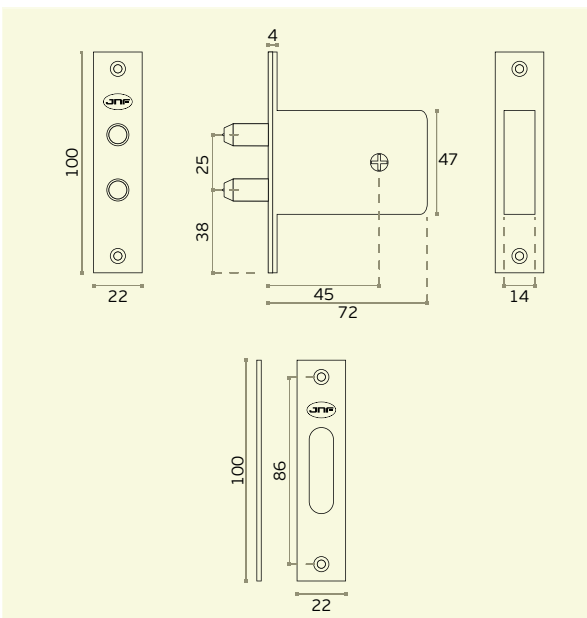

IN.20.200

Fechadura de serviço para portas técnicas /
Lock service for technical doors /
Cerradura de servicio para puertas técnicas /

Material: EN 1.4301
Satinado / Satin / Satin

IN.20.200.C

Chave /
Key / Llave

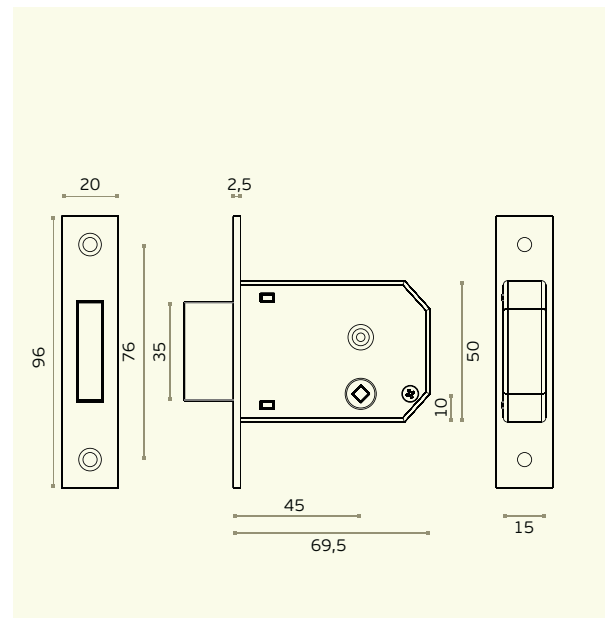

FECHADURAS AUXILIARES E TRINCOS / AUXILIARY LOCKS AND LATCHES / CERRADURAS Y CERROJOS AUXILIARES.

IN.20.152

Trinco reversível para casa de banho.
Para aplicar com fecho livre-ocupado /

Adjustable latch for bathroom.
To use with snib indicators. /

Picaporte reversible para baño.
Para aplicar con condenas de baño.

Material: EN 1.4301
Satinado / Satin / Satin

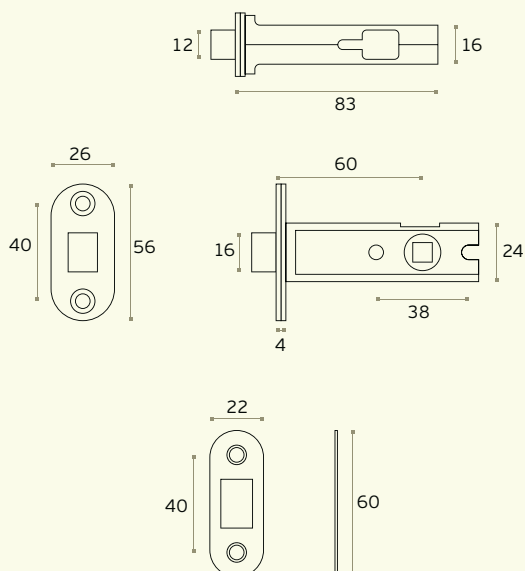

IN.20.153

Trinco magnético reversível para puxador /
Adjustable magnetic latch for lever handle. /
Picaporte magnetico reversible para manilla.

Material: EN 1.4301
Satinado / Satin / Satin

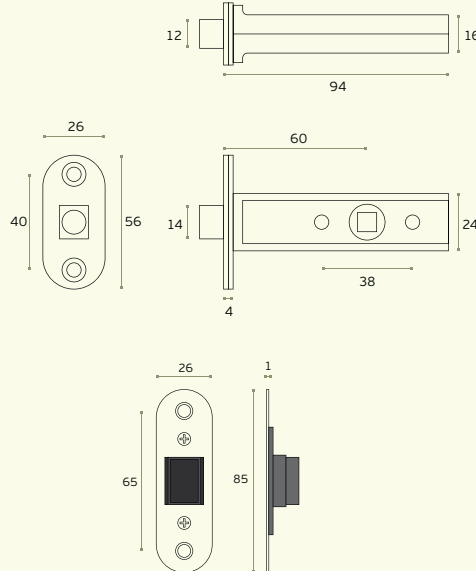

IN.20.799.6

IN.20.799.8

Trinco reversível para casa de banho.
Para aplicar com fecho livre-ocupado /

Adjustable latch for bathroom.
To use with snib indicators. /

Picaporte reversível para banho.
Para aplicar com condensas de banho.

Material: EN 1.4301
Satinado / Satin / Satin

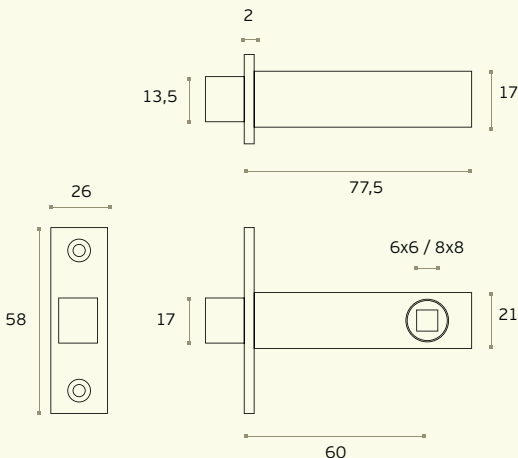

20.7706

Fechadura de armário para cilindro
Europeu, aplicável sobreposta no interior
de gavetas ou armários. Aconselhável a
aplicação com meio cilindro. Reversível. /

European cylinder lock for cabinet to
applicable overlapped inside drawers or
cabinets. Suitable the application with half
cylinder. Reversible. /

Cerradura de mueble para bombillo Europeo
aplicable sobrepuesto en el interior de
cajones o armarios. Aconsejó la aplicación
con medio bombillo. Reversible.

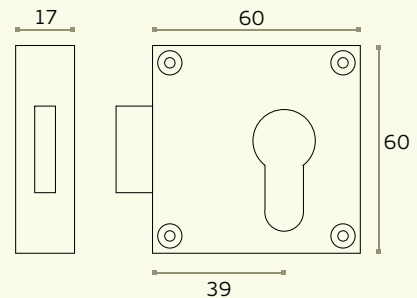

SÉRIE 400 - FECHADURAS PARA PERFIS ESTREITOS / 400 SERIES - LOCKS FOR NARROW PROFILES / SERIE 400 - CERRADURAS PARA PERFILES ESTRECHOS.

Fechaduras JNF para portas metálicas ou pvc. Desenvolvidas para perfis de alumínio, pvc e metálicos com diferentes distâncias, 25, 30 e 35 mm.

Para obter um fecho suave e silencioso foi incorporado um trinco silencioso.

JNF locks for hollow and narrow profile section doors. Developed for aluminium, pvc and metallic frames with 3 different backsets, 25, 30 and 35 mm.

For a smooth and silent operation it was added a silent latch.

Cerraduras JNF para puertas de perfil hueco y estrecho. Desarrollado para perfiles de aluminio, pvc y metal con diferentes distancias, 25, 30 y 35 mm. Para un cierre suave y silencioso se incorporó un cierre silencioso.

Quadra com mola interior para eliminação da folga entre o puxador e quadra / Handle square hole with a internal spring to avoid any break between the Spindle and the lock / Nueca en acero inox con muelle interior para eliminar la holgura entre la manilla y nueca.

Furação para fixação do puxador / Handle fixing holes /
Agujeros para tornillos pasantes.

Preparada para cilindro europeu / Ready for european cylinder /
Preparada para bombillo europeo.

Backset 25 - 30 - 35 mm /



Trinco silencioso reversível em aço inox EN 1.4301 com silenciador intermédia em Nylon/ Reversible silent latch made in stainless steel EN 1.4301 with noise free nylon insert / Picaporte silencioso reversible en acero inox EN 1.4301 con silenciador en nylon.

Língua em aço inox EN 1.4301/ Dead bolt made in stainless steel EN 1.4301 /
Pestillo en acero inox EN 1.4301.

Aço Inox / Stainless steel /
Acero inoxidable.

IN.20.400.25

IN.20.400.30

IN.20.400.35

Fechadura de embutir para portas de perfil estreito - Para cilindro europeu /

Mortise door lock for hollow and narrow profile section doors - For european cylinder /

Cerradura de embutir para puertas de perfil hueco y estrecho - Para bombillo europeo.

Material: EN 1.4301
Satinado / Satin / Satin



IN.20.400.25

IN.20.400.30

IN.20.400.35

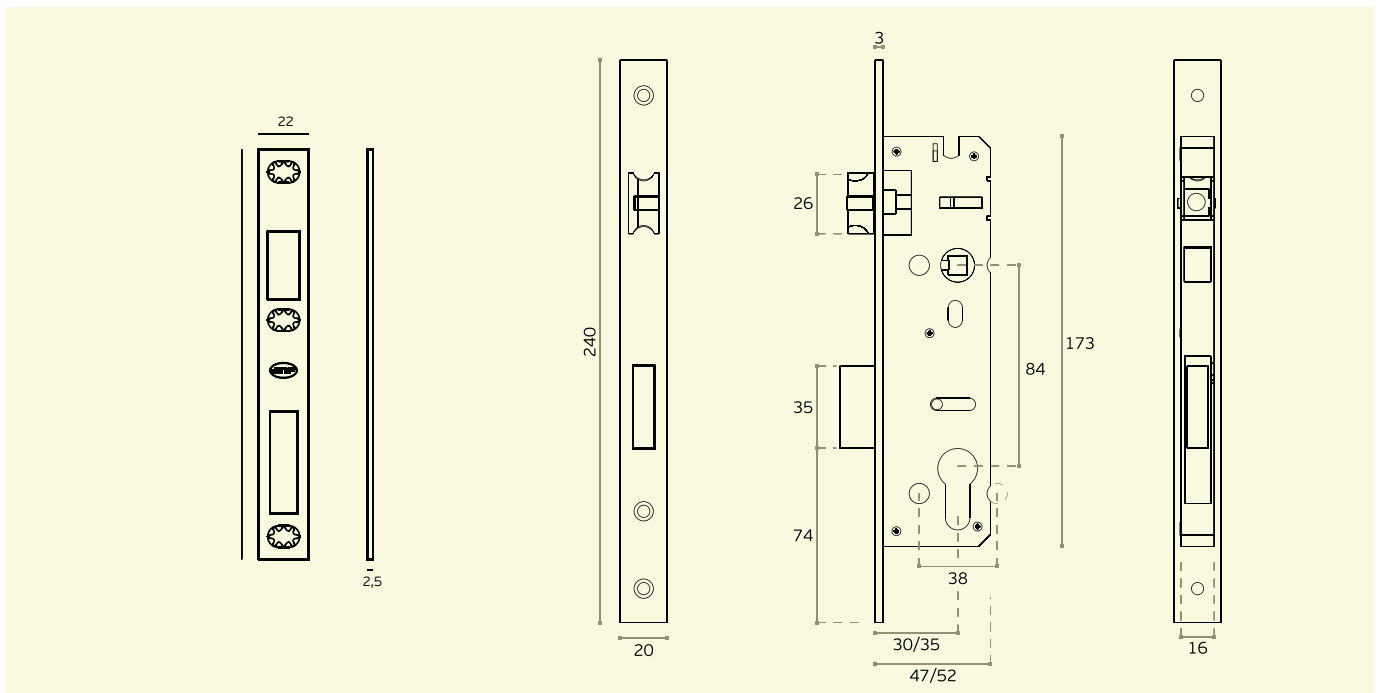

FECHADURAS PARA PORTAS DE CORRER / MORTISE LOCKS FOR SLIDING DOORS / CERRADURAS PARA PUERTAS CORREDERAS

Caixa fechada em aço inox EN 1.4301 /
Closed lock case made in stainless steel EN 1.4301 /
Caja cerrada en acero inox EN 1.4301.

Preparada para cilindro europeu /
Ready for european cylinder /
Preparada para bombillo europeo.

Frente em aço Inox EN 1.4301 /
Front plate made in stainless steel EN1.4301 /
Frente en acero inoxidable EN 1.4301.

Puxador retráctil em aço inox EN 1.4301 /
Retractable handle made in Stainless steel EN 1.4301 /
Manilla retractil en acero inox EN 1.4301.



Botão para activar o puxador retráctil /
Button to activate the retractable handle /
Botón para activar la manilla retractil.

Língua em aço inox EN 1.4301 /
Dead bolt made in stainless steel EN 1.4301 /
Pestillo en acero inox EN 1.4301.

NEW

IN.20.501

Fechadura de embutir com puxador retráctil para portas de correr/
Mortise door lock with retractable handle
for sliding doors/
Cerradura de embutir con manilla retráctil para
correderas.

Material: EN 1.4301
Satinado / Satin / Satin



OPCIONAL/OPTIONAL

IN.20.AKN

Adaptador para chave normal.

Adapter for normal key.
Adaptador para llave normal.



IN.20.AWC

Adaptador para fecho WC /
Adapter for snib indicator /
Adaptador para condena de
baño.

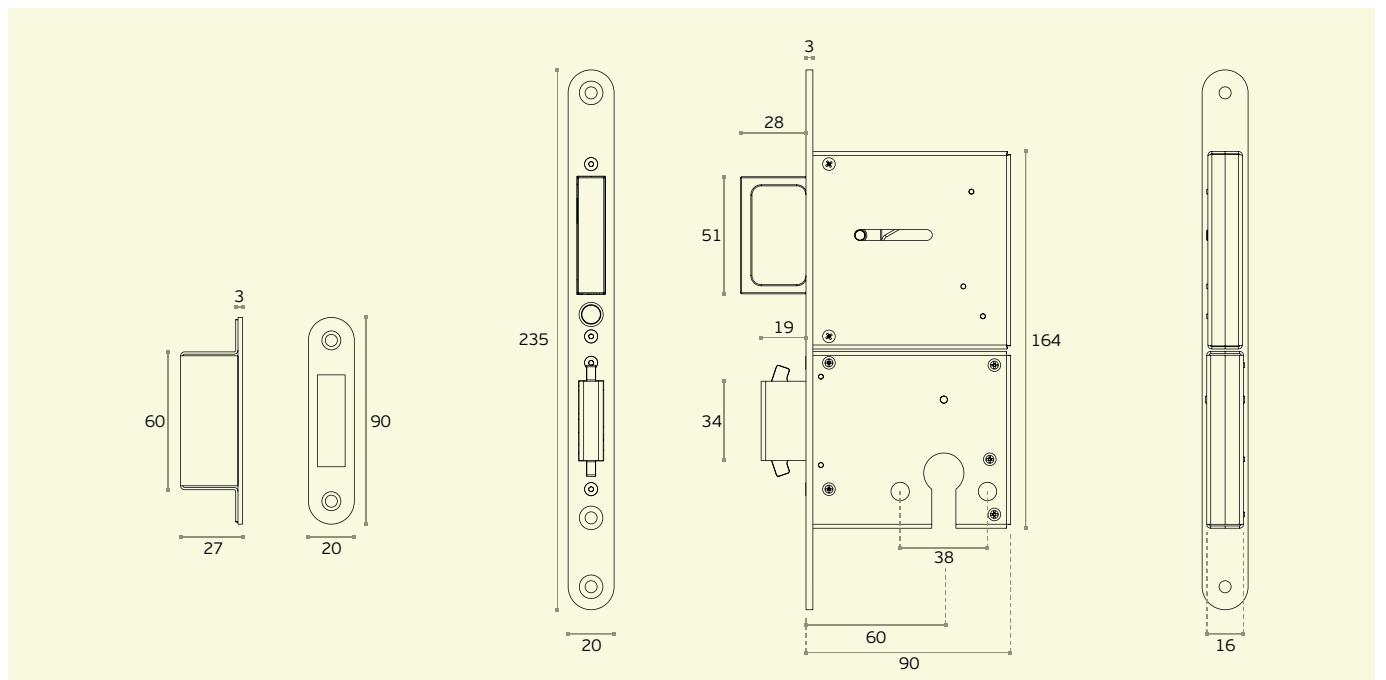

FECHADURAS PARA PORTAS DE CORRER / MORTISE LOCKS FOR SLIDING DOORS / CERRADURAS PARA PUERTAS CORREDERAS

NEW

IN.20.500

Fechadura de embutir para portas de correr /
Mortise door lock for sliding doors /
Cerradura de embutir para puertas correderas

Material: EN 1.4301

Satinado / Satin / Satin



OPCIONAL/OPTIONAL

IN.20.AKN

Adaptador para chave normal.

Adapter for normal key.
Adaptador para llave normal.

**IN.20.AWC**

Adaptador para fecho WC /
Adapter for snib indicator /
Adaptador para condena de baño.

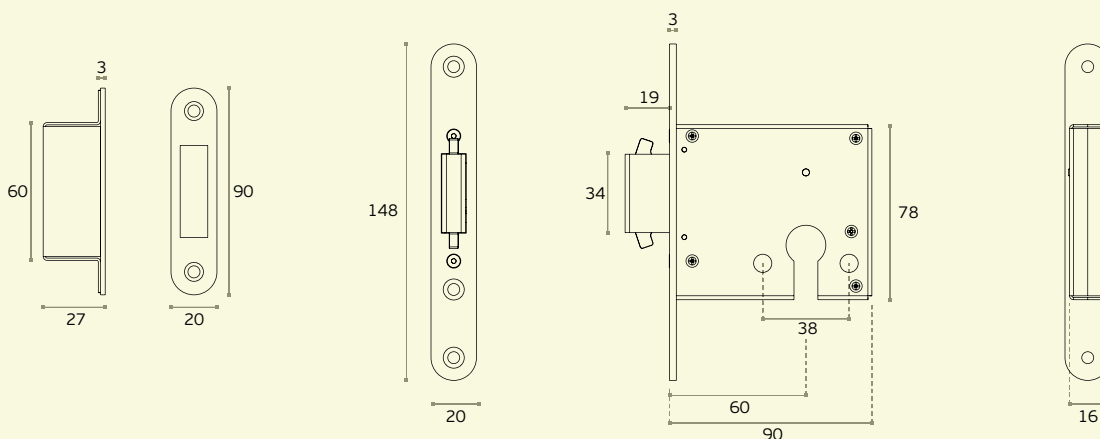

IN.20.915.S

Fechadura de embutir para portas de correr
Gancho, frente e chapa testa em Aço inox EN 1.4301 /

Mortise door lock for sliding doors.
Hook, front and strike plate made in stainless steel
EN 1.4301 /

Cerradura de embutir para puertas correderas .
Gancho, frente y cerradero en acero inox EN 1.301.

Material: EN 1.4301
Satinado / Satin / Satin

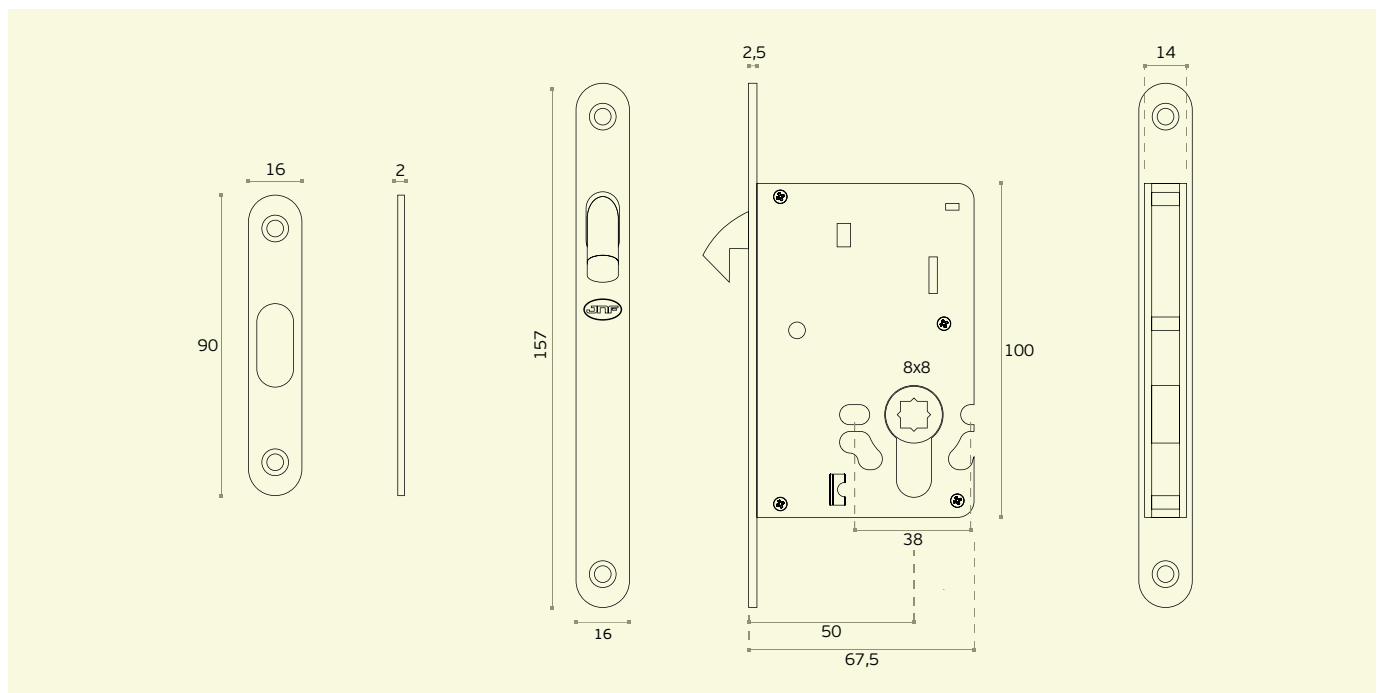

FECHADURAS PARA PORTAS DE CORRER / MORTISE LOCKS FOR SLIDING DOORS / CERRADURAS PARA PUERTAS CORREDERAS

IN.20.241.F

Fechadura de embutir para portas de correr.

Gancho, frente e chapa testa em Aço inox EN 1.4301.

Fornecida com conjunto de puxadores para embutir /

Mortise door lock for sliding doors.

Hook, front and strike plate made in stainless steel EN 1.4301.

Supplied with complete set of flush handles /

Cerradura de embutir para puertas correderas.

Gancho, frente y cerradero en acero inox EN 1.301.

Suministrada con conjunto de tiradores de embutir.

Material: EN 1.4301

Satinado / Satin / Satin

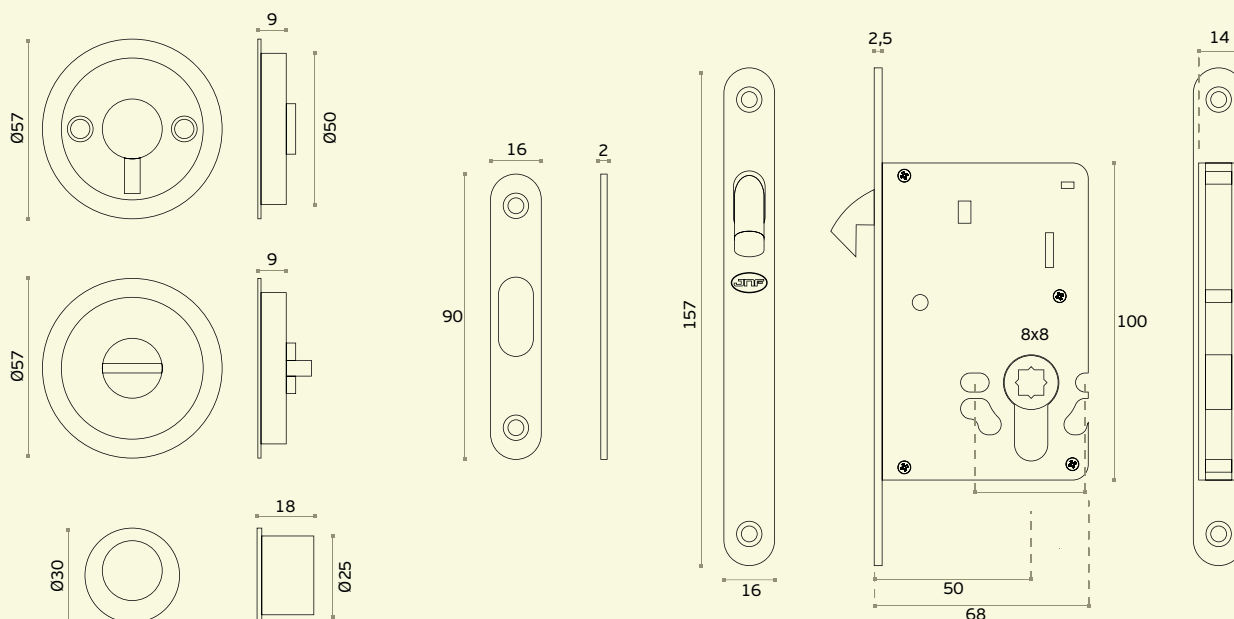

IN.20.922

**Fechadura de embutir para portas de correr.
Entrada para cilindro europeu.
Gancho, frente e chapa testa em aço inox EN
1.4301 /**

Mortise door lock for sliding doors.
Prepared for european cylinder.
Hook, front and strike plate made in stainless
steel EN 1.4301 /

Cerradura de embutir para puertas correderas.
Con entrada para bombillo europeo.
Gancho, frente y cerradero en acero inox
EN 1.4301.

Material: EN 1.4301
Satinado / Satin / Satin



OPCIONAL/OPTIONAL

IN.20.AKN Adaptador para chave normal.

Adapter for normal key.
Adaptador para llave
normal.



IN.20.AWC Adaptador para fecho WC / Adapter for snib indicator / Adaptador para condena de baño.

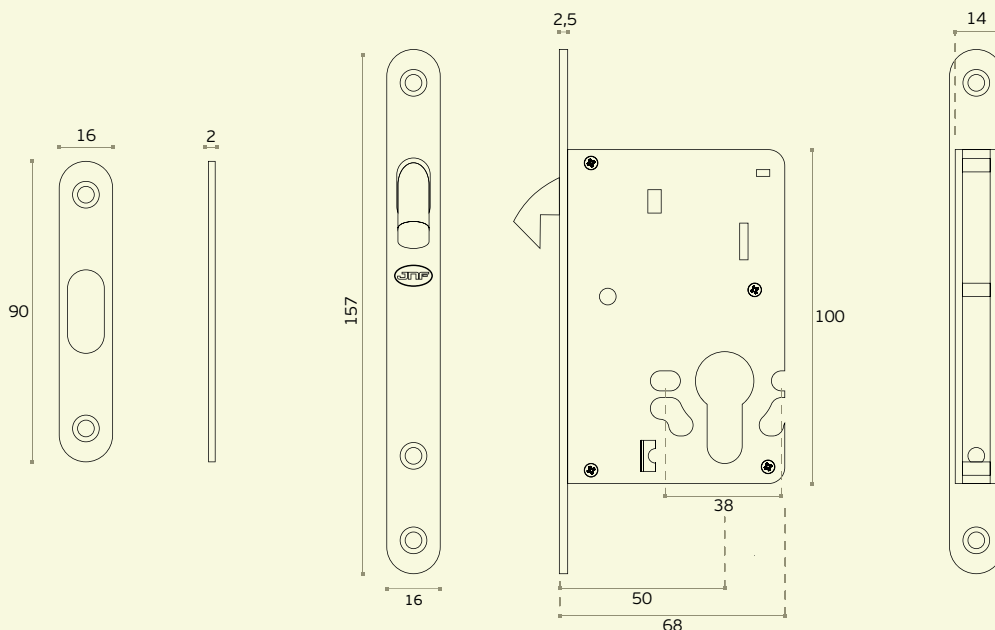

FECHADURAS PARA PORTAS DE CORRER / MORTISE LOCKS FOR SLIDING DOORS / CERRADURAS PARA PUERTAS CORREDERAS

20.937.NS

Fechadura de embutir para portas de correr.

Gancho, frente e chapa testa em aço inox

EN 1.4301.

Fornecida com conjunto de puxadores de embutir em liga de zinco com acabamento em níquel satinado /

Mortise door lock for sliding doors.

Hook, front and strike plate made in stainless steel

EN 1.4301. Supplied with complete set of flush handles

made in zinc alloy with satin nickel finish /

Cerradura de embutir para puertas correderas.

Gancho, frente y cerradero en acero inox

EN 1.4301. Suministrada con conjunto de cazoletas de embutir en zamak y acabado en niquelado satin.

Material: EN 1.4301

Satinado / Satin / Satin



Também disponível /

Also available /

Tambien disponible.

20.937.CM

Cromado mate /

Matte Chrome plated /

Cromado Satin.



20.937.LB

Bronzeado / Bronze /

Bronce.

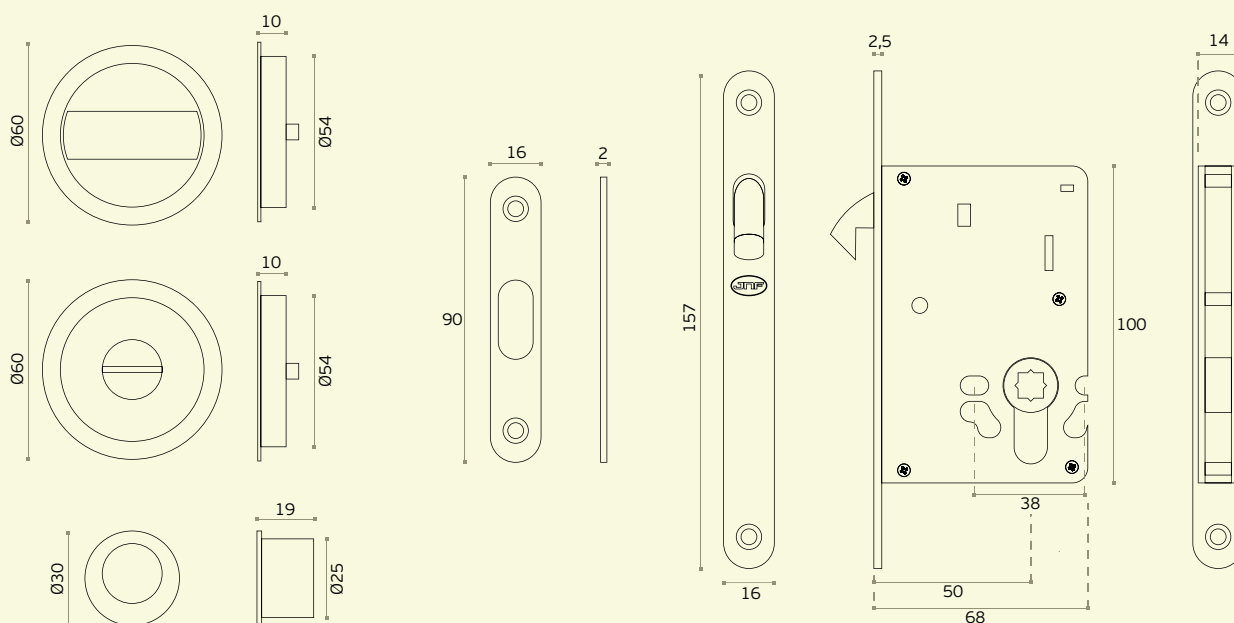

20.938.NS

Fechadura de embutir para portas de correr.
Frente e chapa testa em aço inox EN 1.4301.
Fornecida com conjunto de puxadores de embutir em liga de zinco com acabamento em níquel satinado /

Mortise door lock for sliding doors.
Front and strike plate made in stainless steel EN 1.4301.
Supplied with complete set of flush handles made in zinc alloy with satin nickel finish /
Cerradura de embutir para puertas correderas.
Frente y cerradero en acero inox EN 1.301.
Suministrada con conjunto de cazoletas de embutir en zamak y acabado en niquelado satin.

Material: EN 1.4301
Satinado / Satin / Satin



Também disponível /
Also available/
Tambien disponible.

20.938.CR

Cromado/
Chrome plated /
Cromado Brillo.



20.938.CM

Cromado mate/
Matte Chrome plated /
Cromado Satin.



20.938.D

Dourado/ Gold Plated/
Latón Pulido.



20.938.LB

Bronzeado/ Bronze /
Bronze.

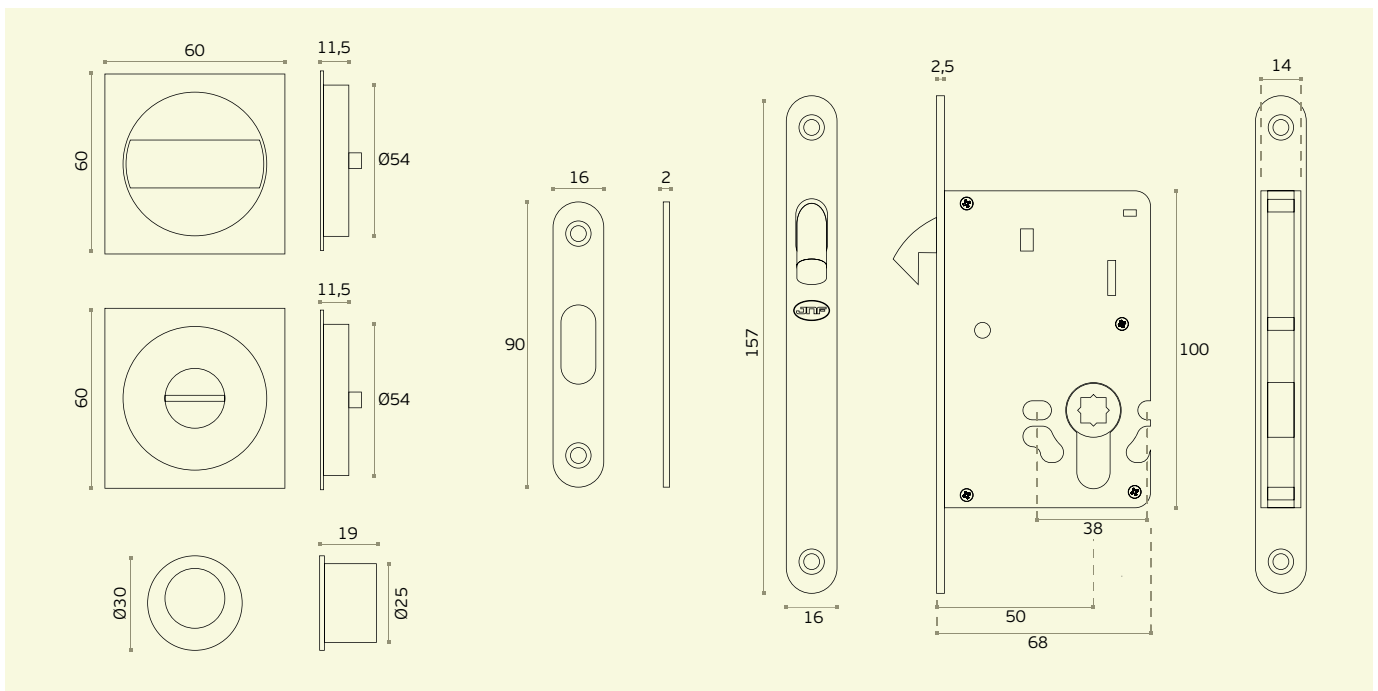

FECHADURAS PARA PORTAS DE CORRER / MORTISE LOCKS FOR SLIDING DOORS / CERRADURAS PARA PUERTAS CORREDERAS

20.237

Fechadura de embutir para portas de correr.
Frente e chapa testa em Aço inox EN 1.4301.
Fornecida com conjunto de puxadores para embutir em níquel satinado /

Mortise door lock for sliding doors.
 Front and strike plate made in stainless steel EN 1.4301.
 Supplied with complete set of flush handles made in satin nickel /

Cerradura de embutir para puertas correderas.
 Frente y cerradero en acero inox EN 1.4301.
 Suministrada con conjunto de tiradores de embutir en niquelado satin.

Material: EN 1.4301
 Satinado / Satin / Satin

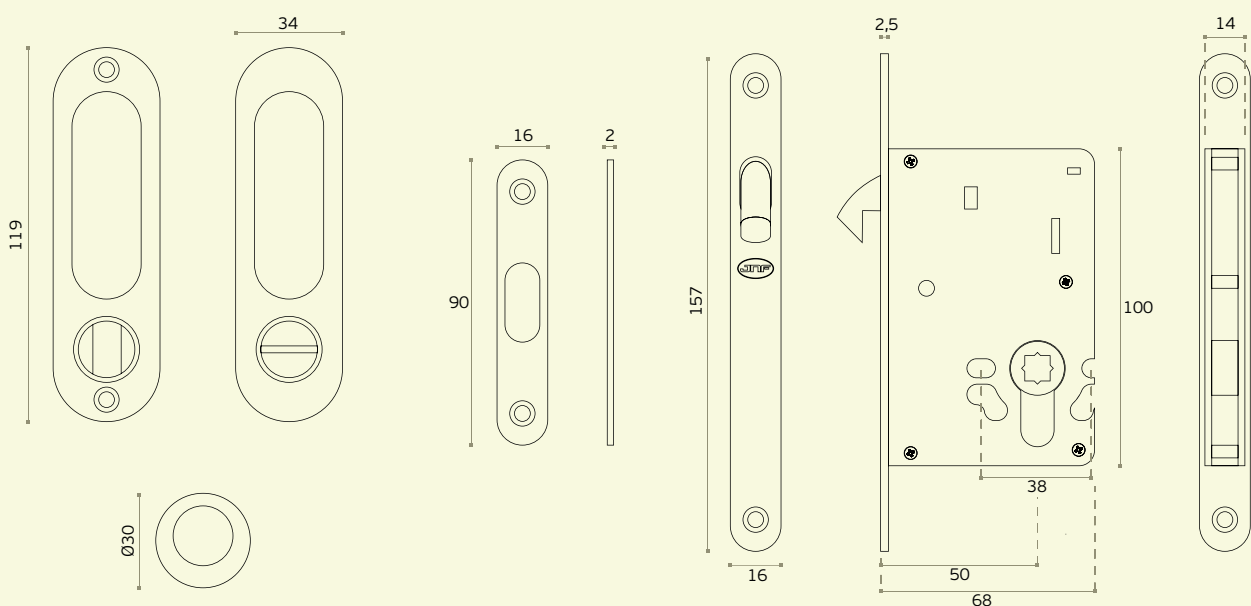

Acessórios para Fechaduras / Locks Accessories / Accesorios para Cerraduras.

IN.20.AKN

Acessório para converter uma fechadura de cilindro em chave normal. 12 combinações possíveis.

Possibilidade de grupos de chaves iguais. /

Accessory to convert a cylinder lock into normal key.
12 possible combinations. Possible groups of equal keys /
Accesorio para convertir una cerradura de bombillo en llave normal. 12 combinaciones posibles.
Posibilidad de grupos de llaves iguales.

Material: Plástico / Plastic / Plástico

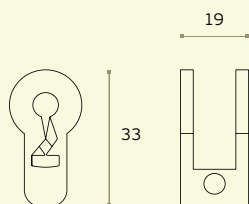

NEW

IN.20.AWC

Acessório para converter uma fechadura de cilindro em fechadura para casa de banho.

Pode ser aplicado com quadras de 6x6 ou 8x8mm./

Accessory to convert a cylinder lock into a bathroom lock.
Allows the use of 6x6 or 8x8mm square spindles./
Accesorio para convertir una cerradura de bombillo en cerradura de condena.
Puede aplicarse quadradillos de 6x6 o 8x8mm.

Material: Plástico / Plastic / Plástico

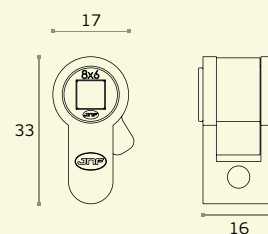



Acessórios para Fechaduras / Locks Accessories / Accesorios para Cerraduras.

IN.20.900

Chapa testa com ajuste de trinco e protecção de aro.

Reversível. Aplicável com Série 890/985/970. /

Strike plate with adjustment of latch and door frame protection. Reversible. Apliable with Série 890/985/970. / Cerradero con ajuste de picaporte y protección de marco de puerta. Regulable. Aplicable con Série 890/985/970.

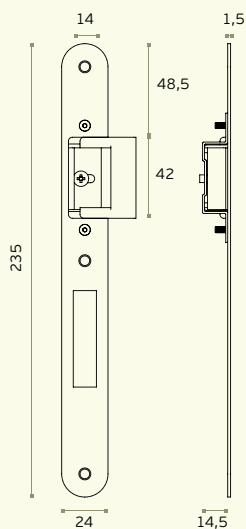

IN.20.903

Chapa testa ajustável e reversível.

Aplicável com Série 890/985/970. /

Adjustable and reversible strike plate. Apliable with Série 890/985/970. / Cerradero regulable y reversible. Aplicable con Série 890/985/970.

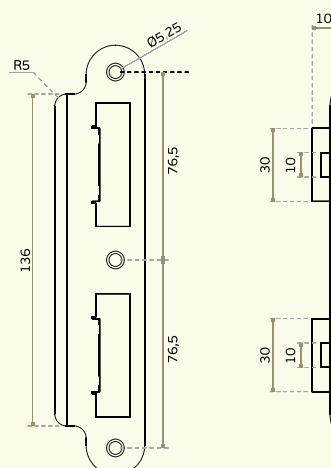

Acessórios para Fechaduras / Locks Accessories / Accesorios para Cerraduras.

IN.20.901.____

Chapa testa ajustável e reversível.
Aplicável com Série 890/985/970./
Adjustable and reversible strike plate.
Aplicable with Série 890/985/970./
Cerradero regulable y reversible.
Aplicable con Série 890/985/970.

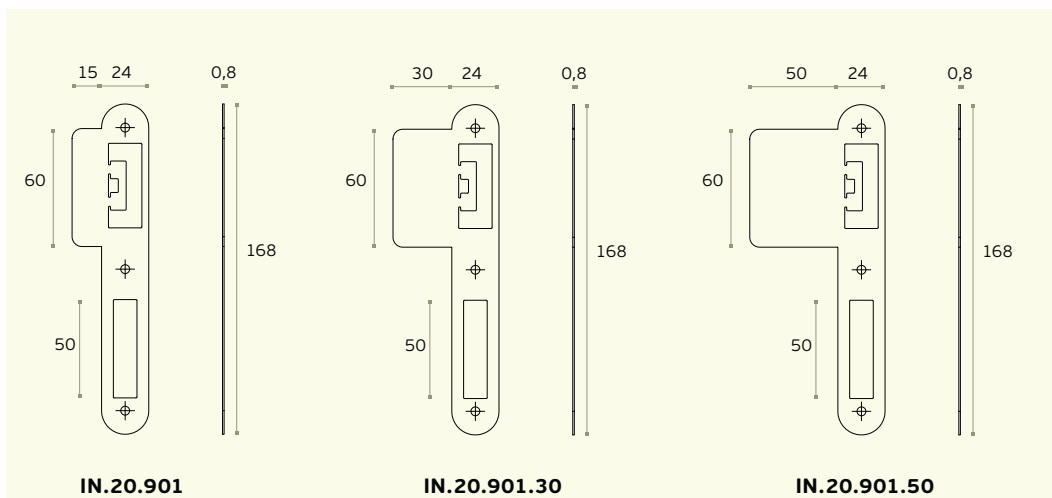

IN.20.902.____

Chapa testa ajustável e reversível.
Aplicável com Série 716/916/815./
Adjustable and reversible strike plate.
Aplicable with Série 716/916/815./
Cerradero regulable y reversible.
Aplicable con Série 716/916/815.

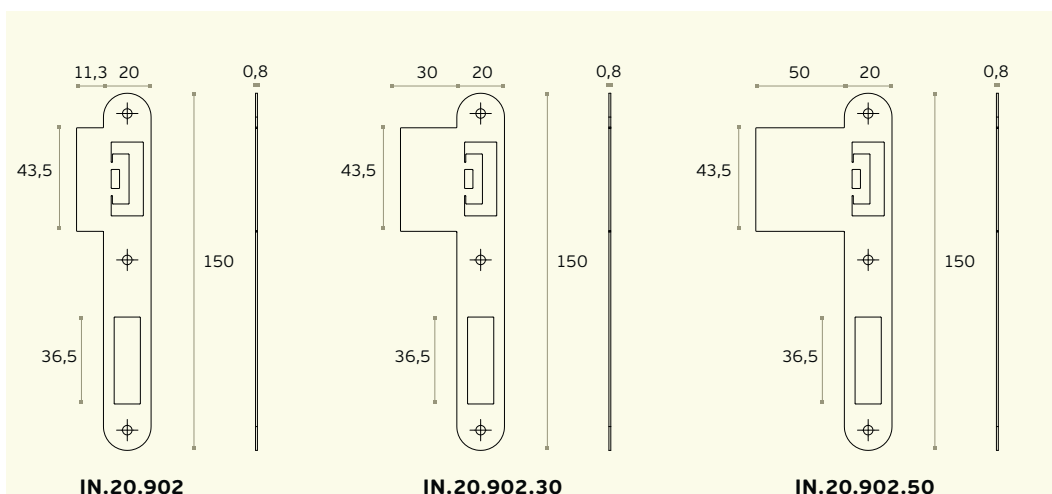

H/1146

■ ■ ■
Sistemas de fecho /
Locking systems /
Sistemas de cierre.

■
Fechaduras /
Locks /
Cerraduras.

FECHADURAS DE ARMÁRIO /

LOCK FOR FURNITURE /

CERRADURA PARA MUEBLES.

20.4000

Fechadura para armário - cacifo/

Lock for furniture - lockers/
Cerradura para muebles - taquillas.

Zamak - Níquel satinado / Satin nickel / Niquel Satin.

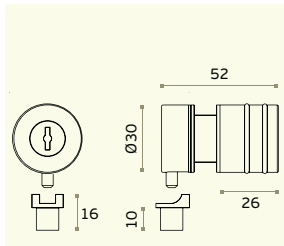

20.4002.CI

Grupo de cilindros amovíveis com chaves iguais para fechadura 20.4000/

Removable cylinder group with key alike for lock 20.4000 /
Grupo de Cilindros amovibles con llaves iguales para cerradura 20.4000.

Níquel satinado / Satin nickel / Niquel Satin.

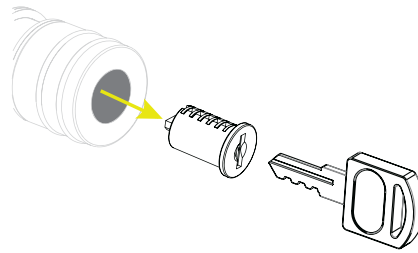

20.4000.CM

Chave mestra.

Master key.
Llave mestra.

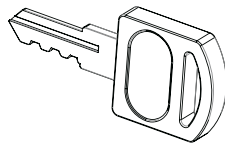

20.4002.CD

Cilindros amovíveis com chaves diferentes para fechadura 20.4000/

Removable cylinder with key different for lock 20.4000/
Cilindros amovibles con llaves distintas para cerradura 20.4000.

Níquel satinado / Satin nickel / Niquel Satin.

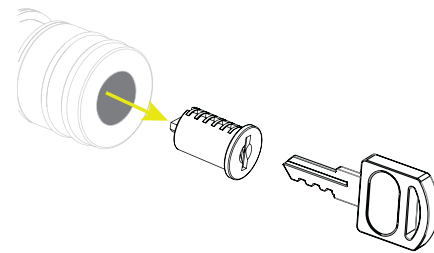

20.4000.CR

Chave para remoção do cilindro.

Cylinder changing key.
Llave para quitar el bombillo.

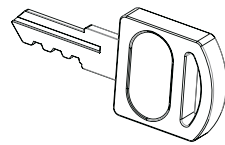

20.4001

Identificador para fechadura 20.4000 /

Identifier for lock 20.4000 /

Identificador para cerradura 20.4000.

Números - 1 a 200 /
Numerals - 1 to 200 /
Numeros - 1 a 200.

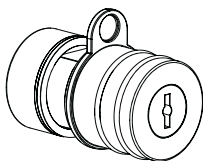

20.4003

Chapa testa para fechadura 20.4000 /

Strike plate for lock 20.4000 /

Cerradero para cerradura 20.4000.

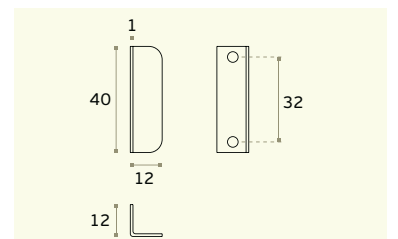

FECHADURAS DE ARMÁRIO / LOCK FOR FURNITURE / CERRADURA PARA MUEBLES.

07715.20**07715.25****07715.30****Fechadura com cilindro amovível /**

Lock with removable cylinder /
Cerradura con bombillo amovible.

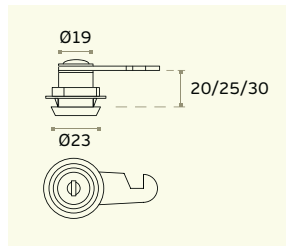
**07715.R.20****07715.R.25****07715.R.30****Fechadura com cilindro amovível /**

Lock with removable cylinder /
Cerradura con bombillo amovible.

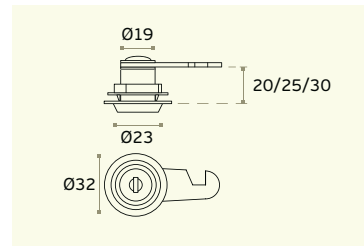
**07715.Q.20****07715.Q.25****07715.Q.30****Fechadura com cilindro amovível /**

Lock with removable cylinder /
Cerradura con bombillo amovible.

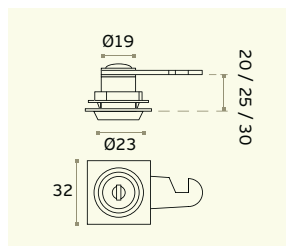
**07715.C****Cilindro amovível para fechadura 07715/**

Removable cylinder for lock 07715/
Bombillo amovible para cerradura 07715.

**07715.CM****Chave mestra /**

Master key /
Llave mestra.

**07715.CR****Chave para remoção do cilindro.**

Cylinder changing key.
Llave para quitar el bombillo.





Fechaduras /
Locks /
Cerraduras.

H/1149



■ ■ ■
Sistemas de fecho /
Locking systems /
Sistemas de cierre

■
Cilindros /
Cylinders /
Cilindros.

■
www.jnf.pt

CILINDROS/ CYLINDERS/ CILINDROS.



CILINDROS DE ALTA SEGURANÇA

JNF e EVVA desenvolveram um perfil de chave exclusivo garantindo dessa forma que apenas a JNF possa realizar cópias de chave para os respectivos cilindros, sendo impossível a cópia por outros meios.

EVVA é um dos fabricantes de cilindros mais conceituados da Europa, produzindo os mais sofisticados e seguros sistemas de cilindros do mercado.

JNF dispõe duma avançada tecnologia que lhe permite realizar cópias de chaves, sistemas de cilindros com chaves iguais e planos de mestragem.

HIGH SECURITY CYLINDERS

JNF and EVVA developed an exclusive profile of key ensuring that only JNF can carry through copies of key by the respective cylinders, being impossible the copy for other ways.

EVVA is one of the best manufacturers of cylinders in Europe, producing the most sophisticated and safe systems of cylinders in the market.

JNF makes use of an advanced technology that allows it to carry through copies of keys, systems of cylinders with key alike and master key systems.

CILINDROS DE ALTA SEGURIDAD

JNF y EVVA han desarrollado un perfil de llave exclusivo de forma a garantizar que solamente JNF puede realizar copias de la llave para los cilindros respectivos, siendo imposible la copia por otros medios.

EVVA es uno de los mejores fabricantes de cilindros en Europa, produciendo los sistemas más sofisticados y más seguros del mercado.

JNF hace uso de una tecnología avanzada que permite realizar copias de llaves, sistemas de cilindros con llaves iguales y maestramientos.





3KS



ICS



DPS



S30





Cilindros /
Cylinders /
Cilindros.

WALSA



S22

S20

S10

S05



ICONOGRAFIA - CARACTERÍSTICAS TÉCNICAS / ICONOGRAPHY - TECHNICAL DATA / ICONOGRAFÍA - CARACTERÍSTICAS TÉCNICAS



Certificado segundo a Norma Europeia /
 Certifying Accordingly to the European Norm /
 Certificadas segundo la Norma Europea.



Certificado segundo a Norma Europeia /
 Certifying Accordingly to the European Norm /
 Certificadas segundo la Norma Europea.



Utilização para sistemas Corta Fogo/
 Use for fire proof systems /
 Uso para sistemas corta fuego.



Sistemas anti-brocagem /
 Anti drilling system /
 Sistema anti-taladro.



Cilindro com chave de ambos os lados /
 Cylinder with key on both sides /
 Cilindro con llave en ambos lados.



Cilindro com ranhura de um lado e botão do outro /
 Cylinder with groove on one side and button of the other /
 Cilindro con surco en un lado y botón del otro.



Cilindro com chave de um lado e botão do outro /
 Cylinder with key on one side and button on the other side /
 Cilindro con llave de un lado e botón del otro.



Meio Cilindro com chave de um lado/
 Half Cylinder with key on one side only /
 Medio Cilindro con llave solo de un lado.



Número de chaves por cilindro/
 Number of keys by cylinder /
 Numero de llaves.



Permite planos de mestragem/
 Allows plans of master key system /
 Capacidad de crear planos de amaestramiento.



Número de combinações diferentes possíveis/
 Number of Different combinations /
 Numero de combinaciones distintos.



Grupos de cilindros com chaves iguais. /
 Key alike cylinder groups. /
 Grupos de cilindros con llaves iguales.



Sistema de dupla acção (abre mesmo com uma chave introduzida no interior) /
 Dual action system (opens even with key introduced in the interior) /
 Sistema de doble embrague (abre incluso con la llave introducida en el interior).





COMO ENCOMENDAR ?

Referência +
Tamanho + (botão) +
(dupla acção) +
(Mestragem)

HOW TO ORDER ?

Reference +
Size + (button) +
(double action) +
(Master Key)

CÓMO ORDENAR ?

Referencia +
tamaño + (botón) +
(doble embrague) +
(Amaestramiento)

NORMA EUROPEIA - EN1303/ EN1303 - EUROPEAN STANDARD / NORMA EUROPEA - EN1303

CILINDROS PARA FECHADURAS - REQUISITOS E MÉTODOS DE ENSAIO

Categoria de uso:
JNF efectua ensaios de resistência de acordo com a referida norma, garantindo um nível máximo de segurança e funcionamento respeitando os requisitos definidos. Os cilindros encontram-se classificados conforme o seguinte quadro:



No entanto, determinados cilindros ultrapassam o nível máximo definido pela norma, a JNF criou uma iconografia com objectivo de identificar e classificar os cilindros de qualidade superior de uma forma intuitiva:

However, certain cylinders exceed the maximum level set by the standard, JNF has created an iconography with the aim of identifying and classify top quality cylinders in an intuitive way:

Sin embargo, ciertos cilindros superan el nivel máximo establecido por la norma, JNF ha creado una iconografía con el objetivo de identificar y clasificar los cilindros de alta calidad de una forma intuitiva:

1 – Segurança mínima
Minimum Security

2 – Segurança média /
Medium Security / Seguridad media

3 – Segurança Alta - Nível máximo definido pela norma /
High security / Max grade defined in standard / Seguridad máxima - Nivel máximo fijado por la norma

4 – High security plus Nível superior aos requisitos da norma /
Higher level than standard requirements / Nivel superior de los requisitos de la norma

CYLINDERS FOR LOCKS - REQUIREMENTS AND TEST METHODS

Category of use:
JNF makes resistance tests in accordance with this standard, ensuring maximum safety and operating in compliance with the defined requirements. The cylinders are classified according to the following table:

Só um nível definido /
Only a defined grade /
Sólo un nivel definido

Grade 1:
Utilização por pessoas onde existe baixa probabilidade de uma utilização indevida ou de acidentes. /

For use by people with a high incentive to exercise care and with a small chance of misuse. /
Utilización por personas donde hay una baja probabilidad de mal uso o accidentes.

CILINDROS PARA CERRADURAS - REQUISITOS Y MÉTODOS DE ENSAYO

Categoría de uso
JNF hace test de resistencia, de acuerdo con esta norma, lo que garantiza la máxima seguridad y funciona de conformidad con los requisitos definidos. Los cilindros se clasifican de acuerdo a la siguiente tabla:

Segurança de pessoas /
Safety / Seguridad
Grade 0: Sem requisitos /
No safety requirement /
Sin requisitos

Massa da porta /
Door mass /



Grade 4: 25 000 Cycles
Grade 5: 50 000 Cycles
Grade 6: 100 000 Cycles

Resistência ao fogo /
Fire resistance /
resistencia al fuego
Grade 0: Não aplicável /
Not approved for use on fire
Grade 1: Adequado para utilização portas resistentes ao fogo /
Suitable for use on fire /
Adequado para puertas resistentes al fuego

**Segurança Chave /
Identificados 6 níveis dos
quais se aplicam: /**

Grau 5 :
**Numero de combinações:
30 000 / Numero de pinos:**

Grau 6 :
**Numero de combinações:
100 000 /
Numero de pinos: 6**

**Key related security /
Identified six levels
which apply: /**

Grade 5 :
6 Number of effective differs:
30 000 / number of
moveable detainers: 6

Grade 6 :
Number of effective differs:
100 000 / Number of
moveable detainers: 6

**Seguridad Clave
Identificado seis niveles
que se aplican:**

Grado 5 :
Número de combinaciones: 30
000 /
Número de pinos: 6

Grado 6 :
Número de combinaciones: 100
000 / Número de pinos: 6

Resistência ao ataque /

Grau 0:
**Sem resistência contra
perfuração; Sem resistência
contra ataque mecânico /**

Grau 1:
**3 / 5 minutos contra
perfuração; Resistência contra
ataque mecânico /**

Grau 2:
**5 / 10 minutos contra
perfuração; Resistência
contra ataque mecânico /**

Attack resistance /

Grade 0:
No resistance against drilling;
No resistance against mechanical
attack /

Grade 1:
3 / 5 minutes resistance against
drilling; Resistance against
mechanical attack /

Grade 2:
5/10 minutes resistance against
drilling; Resistance against
mechanical attack /

Resistencia a los ataques

Grado 0:
Sin resistencia contra la
perforación;
Sin resistencia contra las
agresiones mecánicas

Grado 1:
3 / 5 minutos contra la
perforación; Resistencia contra
las agresiones mecánicas

Grado 2:
5 / 10 minutos contra la
perforación; Resistencia contra
las agresiones mecánicas

**Resistência à corrosão e
temperatura/
Grau 0: Sem requisito à
corrosão e temperatura /
Grau A: Alta resistência à
corrosão; Sem requisito à
temperatura /
Grau B: Sem requisito
à corrosão. Requisito
temperatura – 20 °C a 80 °C /
Grau C: Alta resistência
à corrosão; Requisito
temperatura – 20 °C a 80 °C /**

**Corrosion resistance and
temperature /
Grade 0:** No corrosion
requirement; no temperature
requirement /
Grade A: High corrosion
resistance; no temperature
requirement /
Grade B: No corrosion
requirement; temperature
requirement: from – 20 °C to
+ 80 °C /
Grade C: High corrosion
resistance; temperature
requirement: from – 20 °C to
+ 80 °C /

**Resistencia a la corrosión y de la
temperatura /
Grado 0:** Sin requisito de la
corrosión; sin requerimiento
de temperatura /
Grado A: Alta resistencia a la
corrosión; sin requerimiento
de temperatura /
Grado B: Sin requisito a la
corrosión; requerimiento de
temperatura – 20 °C a 80 °C /
Grado C: Alta resistencia a la
corrosión; requerimiento de
temperatura – 20 °C a 80 °C

3KS - CILINDROS DE ALTA SEGURANÇA / 3KS - HIGH SECURITY CYLINDERS / 3KS - CILINDROS DE ALTA SEGURIDAD.

3KS

UMA CHAVE VERDADEIRAMENTE ÚNICA

O cilindro 3KS é um sistema mecânico de alta complexidade .
A chave é reversível, podendo ser introduzida no cilindro em ambas as faces.
Como este mecanismo não utiliza molas para recuperação dos leitores de combinação, a chave é introduzida sem qualquer esforço e o desgaste da chave é desprezável ao longo de décadas de uso.
O numero de combinações é de tal forma elevado, 30.000.000.000, que seria possível equipar uma cidade como Tóquio, sem repetir uma única porta com a mesma combinação. Mas a característica mais fascinante deste sistema é que permitiria em simultâneo fornecer uma chave mestra com capacidade de abertura de todas as portas da cidade . Uma chave 3KS é verdadeiramente única, é incopiável e o cilindro só a ela permite acesso.
Não há limitação quanto ao numero e complexidade de realização dum plano de mestragem.
O proprietário dum chave tem a segurança absoluta de que a mesma não é copiável sem que para isso dê autorização.
As cópias de chave são fabricadas e controladas exclusivamente pela JNF Portugal.

3KS

A TRULY UNIQUE KEY

The 3KS cylinder is a mechanical system of high complexity.
The key is reversible and can be introduced into the cylinder on both sides.
This mechanism does not use springs for recovery of the combination of readers, the key is inserted without any effort and the key wear is negligible over decades of use.
The number of combinations is so large, 30 billion, it would be possible to provide a city like Tokyo, without repeating a single door with the same key combination.
But the most fascinating feature of this system is that would simultaneously provide a master key with opening capacity of all the city doors.
A 3KS key is truly unique and every cylinder only will be accessed by this key.
There is no limit to the number and complexity of realization of a master key plan.
The owner of a key has the absolute assurance that it is not copyable without this given permission.
The copy keys are exclusively made and controlled by JNF Portugal.

3KS

UNA LLAVE ÚNICA DE VERDAD

El cilindro 3KS es un sistema mecánico de alta complejidad. La clave es reversible y se puede introducir en el cilindro en ambas caras. Debido a que este mecanismo no utiliza muelles para la recuperación de los lectores de llave , se introduce la llave sin ningún esfuerzo y el desgaste es insignificante durante décadas de uso.
El número de combinaciones es tan grande, mas de 30 mil millones que sería posible equipar una ciudad como Tokio, sin repetir una única puerta con la misma combinación . Pero la característica más fascinante de este sistema es que sería posible proporcionar simultáneamente una llave maestra con la capacidad de apertura de todas las puertas de la ciudad . Una clave 3KS es realmente única, es incopiável y el cilindro sólo se permite el acceso por esa llave.
No hay límite para el número y la complejidad de realización de un plan de maestramiento.
El propietario de una clave tiene la seguridad absoluta de que no es copiable sin su permiso. La cópia de llaves es exclusivo y controlada por JNF Portugal.

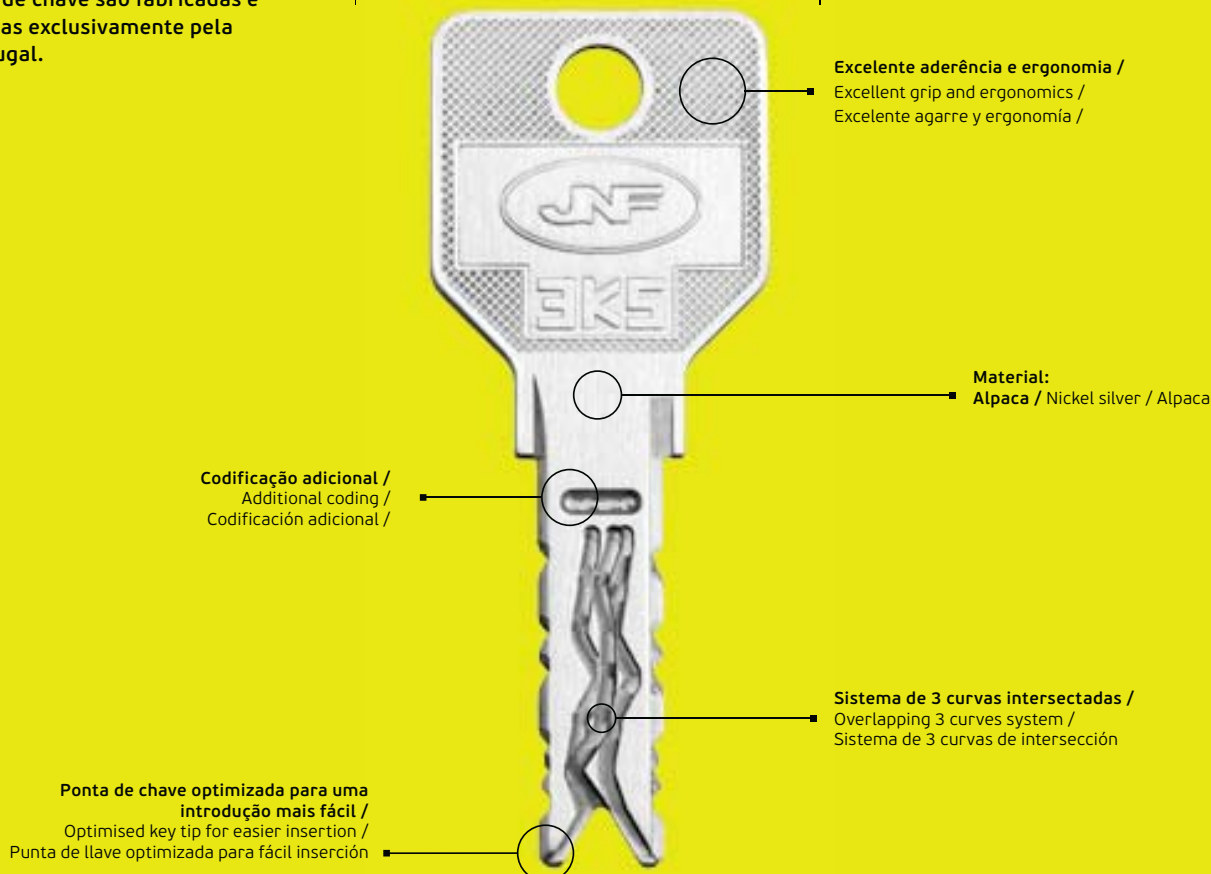

**3KS
CILINDROS PARA OS MAIS EXIGENTES
REQUISITOS DE SEGURANÇA.**

Esta família de cilindros satisfaz os mais elevados requisitos de segurança e durabilidade da norma EN 1303

- Durabilidade ultrapassa largamente o grau 6 da norma EN1303
- Resistência ao Fogo , pode equipar portas corta fogo
- Resistência à corrosão , ultrapassa o Grau C da norma EN1303
- Segurança da chave , ultrapassa infinitamente o grau 6 da norma EN 1303 (norma exige 100.000 combinações diferentes) 30.000.000.000 combinações.
- Resistência ao ataque , ultrapassa largamente o grau 2 da norma EN 1303

Cilindro com características para instalação em edifícios de elevados padrões de segurança: Banca, defesa, aeroportos, instalações de segurança, indústria, ensino, saúde, hotelaria, etc.

**3KS
CYLINDERS FOR THE MOST EXIGENT
SECURITY REQUIREMENTS**

This cylinder family meets the highest safety and durability requirements of EN 1303

- Durability Far exceeds the level 6 of standard EN1303
- Resistance Fire, can equip fire proof doors
- Resistance Corrosion exceeds the Grade C of the standard EN1303
- Security Key, infinitely surpasses the level 6 of EN 1303 (standard requires 100,000 different combinations) 30 billion combinations is reached.
- Resistance The attack, far exceeds the level 2 of EN 1303

Cylinder with features for installation in buildings of high security standards: Banking, defense, airports, security facilities, industry, education, healthcare, hotels, etc

**3KS
CILINDROS PARA LOS REQUISITOS DE
SEGURIDAD MÁS EXIGENTES**

Esta familia de cilindro cumple con los más altos requisitos de seguridad y durabilidad de la norma EN 1303

- Durabilidad Supera el nivel 6 de la norma EN1303
- Resistencia Fuego, puede equipar puertas cortafuegos
- Resistencia a la corrosión excede el grado C de la norma EN1303
- Seguridad de la llave , supera infinitamente el nivel 6 de la norma EN 1303 (norma exige 100.000 combinaciones diferentes) 30 mil millones son garantizados.
- Resistencia El ataque, supera largamente el nivel 2 de la norma EN 1303

Cilindro con características para su instalación en los edificios de altos estándares de seguridad: Banca, defensa, aeropuertos, instalaciones de seguridad, industria, educación, sanidad, hostelería, etc.

**CILINDRO FABRICADO NA ÁUSTRIA. CÓPIAS DE CHAVE FABRICADAS EM PORTUGAL /
CYLINDER MADE IN AUSTRIA. KEY COPIES MADE IN PORTUGAL /
CILINDRO FABRICADO EN AUSTRIA. COPIAS DE LLAVE HECHAS EN PORTUGAL.**

- A - Codificação adicional / additional coding / Pines de cierre**
- B - Corpo do Cilindro / Cylinder body / Cuerpo del cilindro.**
- C - Rolo de engate / Locking roller / Bloqueo de rodillo.**
- D - Codificação adicional / additional coding / Pines de cierre**
- E - Pino de bloqueio / Locking sliders/ pasador de bloqueo.**
- F - Rotor / Cam / Rotor.**
- G - Protecção anti brocagem / Anti-drill / Protección anti taladro.**
- H - Chave / Key / Llave**

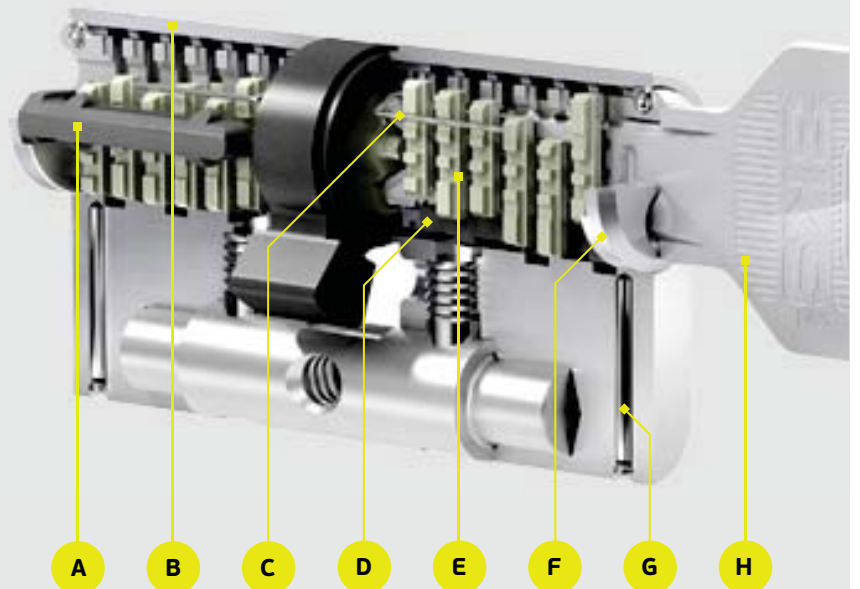

3KS - CILINDROS DE ALTA SEGURANÇA /

3KS - HIGH SECURITY CYLINDERS /

3KS - CILINDROS DE ALTA SEGURIDAD.

IN.19.3KS

CARACTERÍSTICAS:

Cilindro de perfil europeu, com 12 leitores de chave, 12 controladores de leitura de chave, 2 barras de leitura de perfil, Sistema antibrocagem multifacetado, cilindro modular, permite enorme variedade de tamanhos. Sistema de embraiagem que permite abertura pelo exterior mesmo com chave no interior.

Sistema anti-poeiras opcional para a indústria mineira.

Chave de obra opcional.

A maior gama disponível de botões para completa adequabilidade aos restantes elementos de fecho.

Chaves iguais e planos de mestragem sem limitações em número e complexidade.

Perfis disponíveis: Europerfil, cilindro suíço, cilindro nórdico.

FEATURES:

European profile cylinder, with 12 key readers, 12 read key controllers, 2 contour reading bar, Multifaceted anti-drill system, modular cylinder, allows huge variety of sizes. System clutch that allows opening the outside even with key inside.

Anti-dust system optional for the mining industry.

Optional construction key.

The greater range of available buttons

.Suitability to reach the design of other closure elements.

Keys alike and master key plans without limitation in number and complexity.

Profiles available: Europerfil, Swiss cylinder, Nordic cylinder.

CARACTERÍSTICAS:

Cilindro de perfil europeu, com 12 leitores de chave, 12 controladores de leitura de chave, 2 barras de leitura de contorno,

Sistema antitaladro multifacetado, cilindro modular, permite gran variedad de tamaños.

Sistema de embraque que permite la apertura al exterior, incluso con llave en el interior.

Sistema anti-polvo opcional para la industria minera.

Clave de trabajo opcional.

La mayor gama de botones disponibles para adecuación completar los elementos de cierre restantes.

Llaves iguales y planes de maestramiento sin limitación en número y complejidad.

Perfiles disponibles: Europerfil, cilindro suizo, cilindro nórdico.

IN.19.3KS.....B1

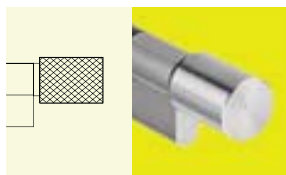

IN.19.3KS.....B2

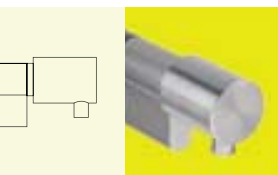

IN.19.3KS.....B3

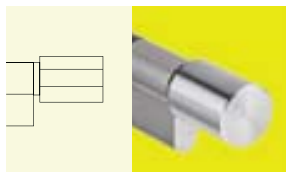

IN.19.3KS.....B4



IN.19.3KS.....B5

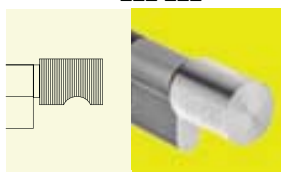

IN.19.3KS.....B6



Mestragem de cilindros (Anexar plano) /
 Master key system
 (Attach master key plan)/
 Cilindros amaestrados
 (Añadir plano de
 amaestramiento)

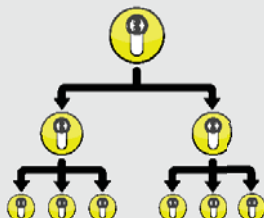

Grupos de chaves iguais (Anexar plano) /
 Key alike group
 (Attach plan) /
 Grupos de llaves iguales
 (Añadir plano).

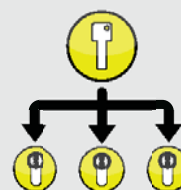



Chaves diferentes /
Different key / Llaves distintas

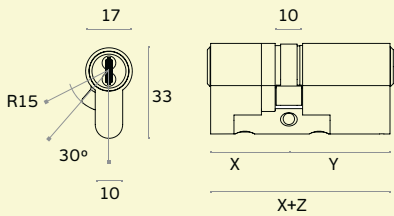

X	Y	X + Z
31	41	72
31	51	82
31	71	102
41	61	102
51	61	112

Chaves diferentes /
Different key / Llaves distintas

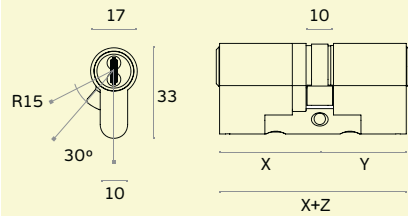

X	Y	X + Z
31	31	62
36	36	72
41	41	82
46	46	92
51	51	102
56	56	112
61	61	122

Chaves diferentes /
Different key / Llaves distintas

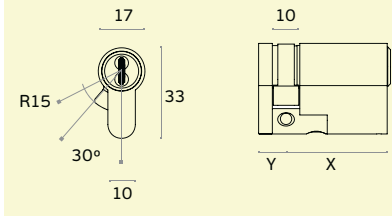

X	Y
41	11



ICS - CILINDROS DE ALTA SEGURANÇA /

ICS - HIGH SECURITY CYLINDERS /

ICS - CILINDROS DE ALTA SEGURIDAD.

ICS

UMA CHAVE | MUITOS ATRIBUTOS

O cilindro ICS é um sistema mecânico de alta segurança com uma das chaves mais sofisticadas do mercado.

A chave é reversível, podendo ser introduzida no cilindro em ambas as faces. O mecanismo utiliza 13 leitores de chave e 2 controladores de perfil.

O número de combinações é semelhante ao sistema 3KS, cerca de 30.000.000.000 o que permite realizar sistemas de segurança de elevada complexidade.

Trata-se do cilindro mais versátil para a realização de planos de mestragem. Não há limitação quanto ao número e complexidade dum plano de mestragem no sistema ICS.

Uma chave ICS é incopiável e o cilindro tem todas as proteções contra abertura fraudulenta.

As cópias de chave são fabricadas e controladas exclusivamente pela JNF Portugal.

ICS

ONE KEY | MANY FEATURES

The ICS cylinder It's a mechanical system of high security with one of the most sophisticated key in the market.

A reversible key allows the user to introduce the same in the cylinder

in both of the faces. The mechanism use 13 key readers and 2 profile controllers.

The number of reached different key combinations is similar to the 3KS cylinder, about 30 billion, the feature allows to perform highly complex security locking systems.

It's the most versatile cylinder to develop master key projects. No limitation about complexity of master key systems at ICS cylinders.

The ICS key is not duplicable and the cylinder is protected against all the fraud opening ways.

The copy keys are exclusively managed and produced by JNF Portugal.

ICS

UNA LLAVE | MUCHOS ATRIBUTOS

El cilindro ICS es un sistema mecánico de alta seguridad con una de las llaves mas sofisticadas del mercado.

La clave es reversible y se puede introducir en el cilindro en ambas caras.

El mecanismo utiliza 13 lectores de clave y 2 controladores de perfil.

El número de combinaciones es semejante al sistema 3KS, mas de 30 mil millones lo que permite realizar sistemas de seguridad de alta complejidad.

Se trata del cilindro más versátil para la producción de pales de maestramiento.

No hay limitaciones al número y complejidad del plan de cierre en el sistema ICS.

Una clave ICS es incopiable y el cilindro esta equipado con todas las protecciones contra apertura fraudulenta.

La copia de llaves es gestionada y producida en exclusivo por JNF Portugal.

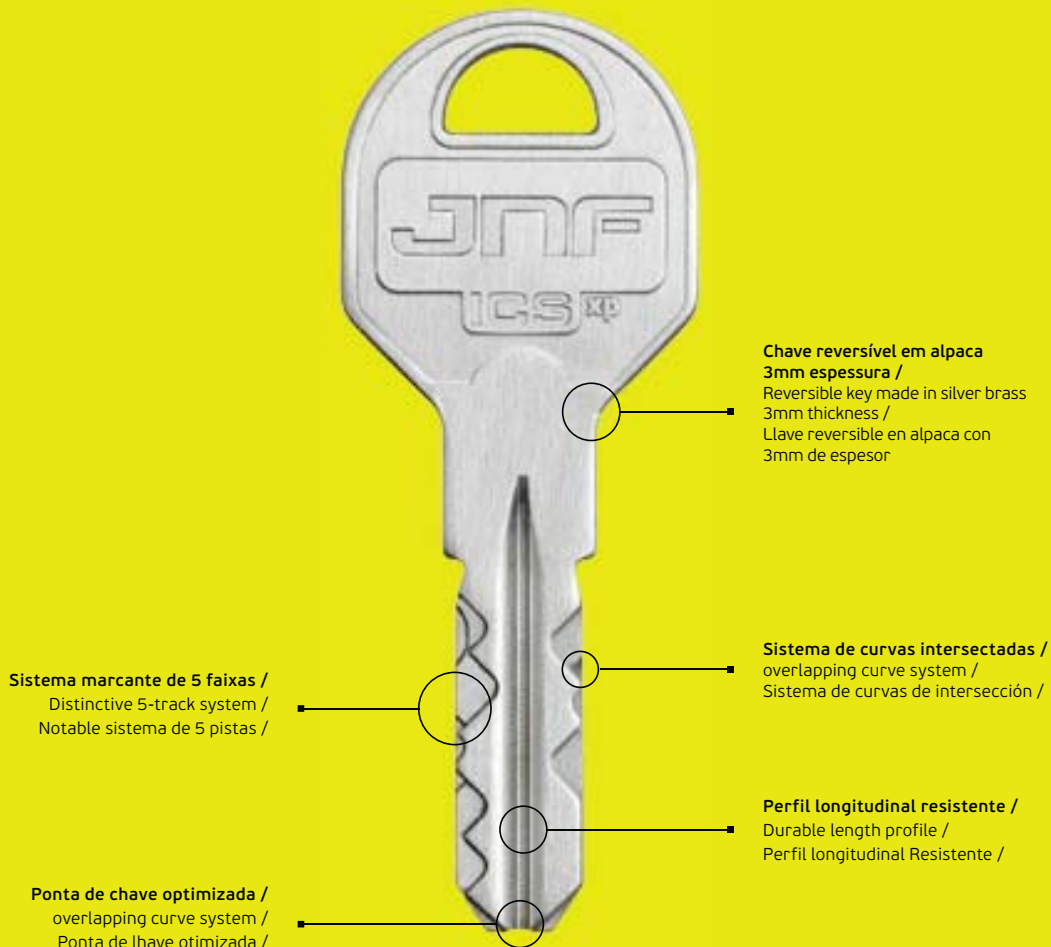

CILINDROS PARA OS MAIS EXIGENTES REQUISITOS DE SEGURANÇA

ICS

Esta família de cilindros satisfaz os mais elevados requisitos de segurança e durabilidade da norma EN 1303

- Durabilidade ultrapassa largamente o grau 6 da norma EN1303
- Resistência ao Fogo , pode equipar portas corta fogo
- Resistência à corrosão , ultrapassa o Grau C da norma EN1303
- Segurança da chave , ultrapassa infinitamente o grau 6 da norma EN 1303 (norma exige 100.000 combinações diferentes) 30.000.000.000 combinações.
- Resistência ao ataque , ultrapassa largamente o grau 2 da norma EN 1303

Cilindro com características para instalação em edifícios de elevados padrões de segurança: Aeroportos, instalações de segurança, centros comerciais, industria, ensino, saúde, hotelaria, uso privado etc.

CYLINDERS FOR THE MOST DEMANDING SECURITY REQUIREMENTS

ICS

This cylinder family meets the highest safety and durability requirements of EN 1303

- Durability Far exceeds the level 6 of standard EN1303
- Resistance Fire, can equip fire proof doors
- Resistance Corrosion exceeds the Grade C of the standard EN1303
- Security Key, infinitely surpasses the level 6 of EN 1303 (standard requires 100,000 different combinations) 30 billion combinations is reached.
- Resistance The attack, far exceeds the level 2 of EN 1303

Cylinder with features for installation in buildings of high security standards: Airports, security facilities, shopping malls , industry, education, healthcare, hotels, private security etc

CILINDROS PARA LOS REQUISITOS DE SEGURIDAD MÁS EXIGENTES

ICS

Esta familia de cilindro cumple con los más altos requisitos de seguridad y durabilidad de la norma EN 1303

- Durabilidad Supera el nivel 6 de la norma EN1303
- Resistencia Fuego, puede equipar puertas cortafuegos
- Resistencia a la corrosión excede el grado C de la norma EN1303
- Seguridad de la llave , supera infinitamente el nivel 6 de la norma EN 1303 (norma exige 100.000 combinaciones diferentes) 30 mil millones son garantizados.
- Resistencia El ataque, supera largamente el nivel 2 de la norma EN 1303

Cilindro con características para su instalación en los edificios de altos estándares de seguridad: Aeroportos, instalaciones de seguridad, centros comerciales, industria, educación, hospitales, hostelería, seguridad privada etc.

CILINDRO FABRICADO NA ÁUSTRIA. CÓPIAS DE CHAVE FABRICADAS EM PORTUGAL / CYLINDER MADE IN AUSTRIA. KEY COPIES MADE IN PORTUGAL / CILINDRO FABRICADO EN AUSTRIA. COPIAS DE LLAVE HECHAS EN PORTUGAL.

- A - Barra de controlo /**
Control bar / barra de control.
- B - Pino do corpo do cilindro /**
Body pin spring / Cuerpo del pin cilindro.
- C - Mola de compressão Pino do corpo do cilindro /**
Body pin spring / Muelle de compresión pin del cuerpo del cilindro.
- D - Mola de compressão para pino de bloqueio /**
Spring for locking slider / Muelle de compresión del pasador de bloqueo.
- E - Pino de bloqueio /**
Locking sliders / pasador de bloqueio.
- F - Pino da faixa /**
Tracking pin / Seguimiento de pin.
- G - Protecção anti brocagem /**
Anti-drill / Protección anti taladro.
- H - Protecção anti brocagem Núcleo /**
Anti-drill / Protección anti taladro.

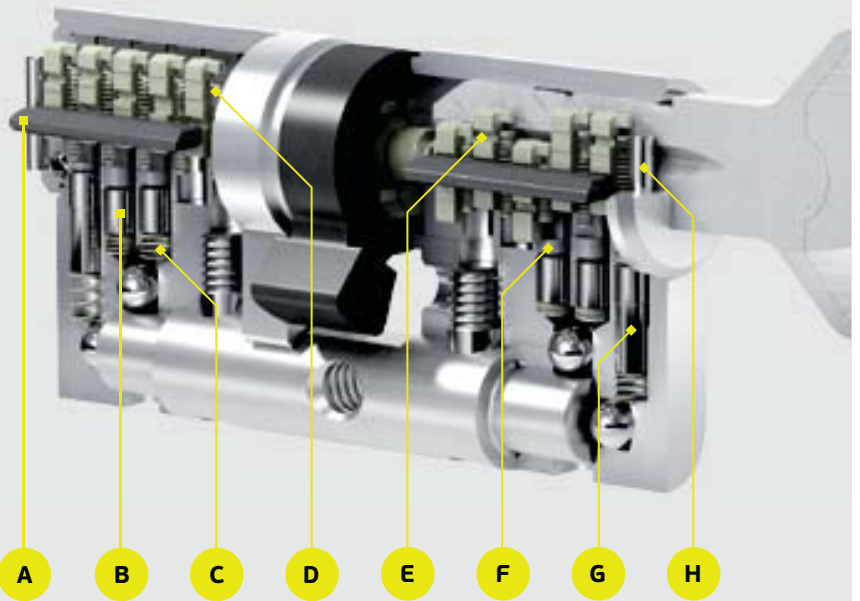

Opções de cilindro ICS

No âmbito de um sistema de fecho, é frequente exigir diferentes opções e requisitos. As opções do ICS tornam isto possível: função do cilindro bloqueável de ambos os lados; função de puxador e antibloqueio; função Vario; proteção contra poeiras e clima; função livre e muito mais. Os certificados internacionais do sistema ICS e os modelos específicos do país possibilitam a sua aplicação em toda a Europa:

ICS cylinder options

Different options and requirements are often called for within a locking system.

The ICS options make it possible: External key override function; SOS function; vario function; dust protection; free-wheel function and much more.

ICS cylinder options

Different options and requirements are often called for within a locking system.

The ICS options make it possible: External key override function; SOS function; vario function; dust protection; free-wheel function and much more.

ICS - CILINDROS DE ALTA SEGURANÇA /

ICS - HIGH SECURITY CYLINDERS /

ICS - CILINDROS DE ALTA SEGURIDAD.

IN.19.ICS

Características:

Cilindro de perfil europeu, com 13 leitores de chave, 2 barras de leitura de perfil, Sistema antibrocagem multifacetado, cilindro modular, permite enorme variedade de tamanhos. Sistema de embraiagem que permite abertura pelo exterior mesmo com chave no interior.

Chave de obra opcional.

A maior gama disponível de botões para completa adequabilidade aos restantes elementos de fecho.

Chaves iguais e planos de mestragem sem limitações em numero e complexidade. Perfis disponíveis: Europerfil, cilindro suízo, cilindro nórdico.

FEATURES:

European profile cylinder, with 13 key readers, 2 contour reading bar, Multifaceted anti-drill system, modular cylinder, allows huge variety of sizes. System clutch that allows opening the outside even with key inside.

Optional construction key.

The greater range of available buttons. Suitability to reach the design of other closure elements.

Keys alike and master key plans without limitation in number and complexity. Profiles available: Europerfil, Swiss cylinder, Nordic cylinder.

CARACTERÍSTICAS:

Cilindro de perfil europeu, con 13 lectores de llave, 2 barras de lectura de contorno, Sistema antitaladro multifacetado, cilindro modular, permite gran variedad de tamaños. Sistema de embrague que permite la apertura al exterior, incluso con llave en el interior.

Clave de obra opcional.

La mayor gama de botones disponibles para adecuación complementar a los elementos de cierre restantes.

Llaves iguales y planes de maestramiento sin limitación en número y complejidad. Perfiles disponibles: Europerfil, cilindro suizo, cilindro nórdico.

IN.19.ICS.....B1

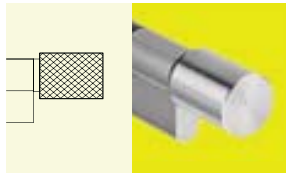

IN.19.ICS.....B2

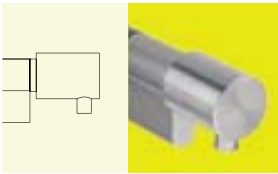

IN.19.ICS.....B3



IN.19.ICS.....B4

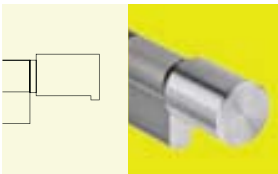

IN.19.ICS.....B5

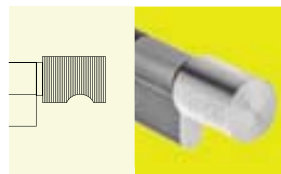

IN.19.ICS.....B6



Mestragem de cilindros (Anexar plano) /
 Master key system
 (Attach master key plan)/
 Cilindros amaestrados
 (Añadir plano de
 amaestramiento)

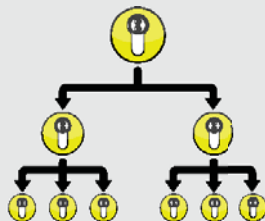

Grupos de chaves iguais (Anexar plano) /
 Key alike group
 (Attach plan) /
 Grupos de llaves iguales
 (Añadir plano).

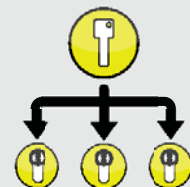



IN.19.ICS.____.

Chaves diferentes /
Different key / Llaves distintas

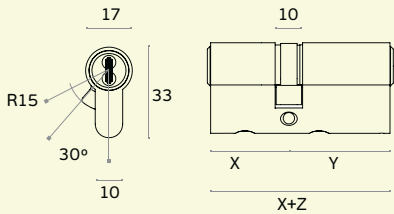

X	Y	X + Z
31	41	72
31	51	82
31	71	102
41	61	102
51	61	112

IN.19.ICS.____.

Chaves diferentes /
Different key / Llaves distintas

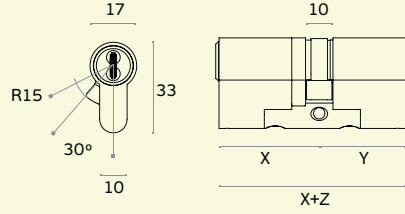

X	Y	X + Z
31	31	62
36	36	72
41	41	82
46	46	92
51	51	102
56	56	112
61	61	122

IN.19.ICS.____.11

Chaves diferentes /
Different key / Llaves distintas

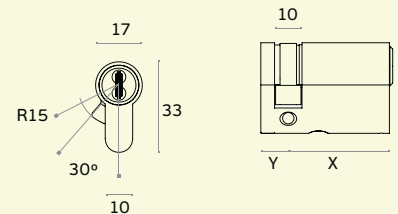

X	Y
31	11
41	11
51	11



DPS - CILINDROS DE ALTA SEGURANÇA /

DPS - HIGH SECURITY CYLINDERS /

DPS - CILINDROS DE ALTA SEGURIDAD.

DPS UMA CHAVE COM PERFIL EXCLUSIVO

O cilindro DPS é um sistema mecânico de alta segurança.

A chave tem um perfil exclusivo, com 5 ranhuras laterais.

O numero de combinações ultrapassa 1.000.000 o que o coloca muito acima do grau 6 da EN1303.

Uma chave DPS é incopiável e o cilindro está provido de todos os sistemas anti-abertura fraudulenta.

Não há limitação quanto ao numero e complexidade de realização dum plano de mestragem.

As cópias de chave são fabricadas e controladas exclusivamente pela JNF Portugal.

DPS A KEY WITH EXCLUSIVE PROFILE

The DPS cylinder is a mechanical system of high security. A DPS key have a exclusive profile with 5 additional grooves.

The number of key combinations is higher than 1.000.000 for that reason this cylinder reach a mush higher level than the 6 Grade of the EN1303

The key cannot be duplicated and the cylinder is provided with all the anti-fraud systems

There is no limit to the number and complexity of realization of a master key plan.

The copy keys are exclusively made and controlled by JNF Portugal.

DPS A KEY WITH EXCLUSIVE PROFILE

El cilindro DPS es un sistema mecánico de alta seguridad.

La llave es de perfil exclusivo, con 5 ranuras laterales.

El numero de combinaciones de llave sobrepasa 1.000.000 característica que coloca este bombillo muy por encima del grado 6 de la norma EN1303.

La llave es imcopianle y el bombillo esta provido de todos los sistemas anti apertura fraudulenta.

No hay límite para el número y la complejidad de realización de un plan de maestramiento.

La cópia de llaves es exclusivo y controlada por JNF Portugal.

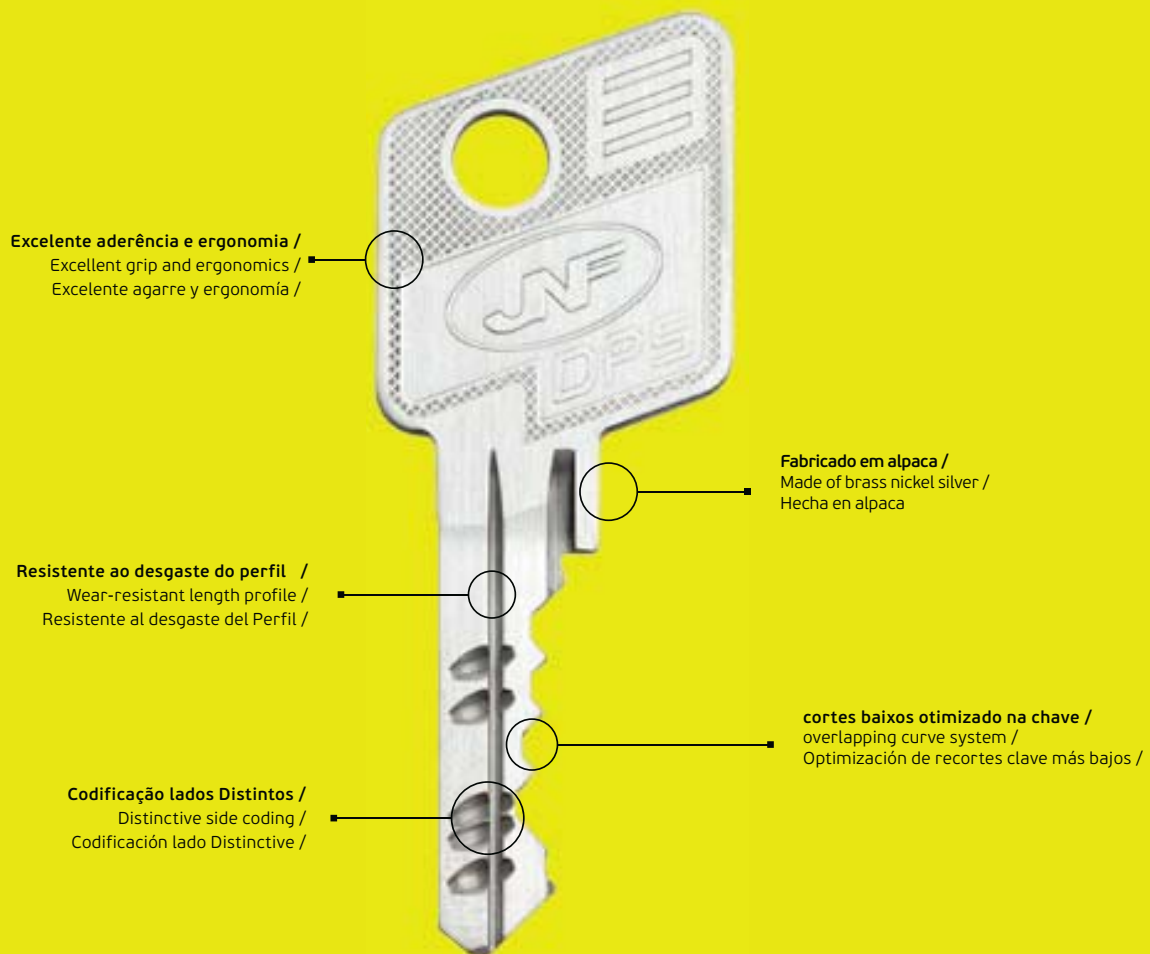

**DPS
CILINDROS PARA ELEVADOS
PADRÕES DE SEGURANÇA**

Esta família de cilindros satisfaz os mais elevados requisitos de segurança e durabilidade da norma EN 1303

- Durabilidade ultrapassa largamente o grau 6 da norma EN1303
- Resistência ao Fogo , pode equipar portas corta fogo
- Resistência à corrosão , ultrapassa o Grau C da norma EN1303
- Segurança da chave , ultrapassa infinitamente o grau 6 da norma EN 1303 (norma exige 100.000 combinações diferentes) 1.000.000 combinações.
- Resistência ao ataque , ultrapassa largamente o grau 2 da norma EN 1303

Cilindro com características para instalação em edifícios com elevados padrões de segurança: Instalações de segurança, indústria, ensino, saúde, hotelaria, segurança privada etc.

**DPS
CYLINDERS FOR THE HIGH
SECURITY REQUIREMENTS**

This cylinder family meets the highest safety and durability requirements of EN 1303

- Durability Far exceeds the level 6 of standard EN1303
- Resistance Fire, can equip fire proof doors
- Resistance Corrosion exceeds the Grade C of the standard EN1303
- Security Key, infinitely surpasses the level 6 of EN 1303 (standard requires 100,000 different combinations) 1.000.000 combinations is reached.
- Resistance The attack, far exceeds the level 2 of EN 1303

Cylinder with features for security doors: Security facilities, industry, education, healthcare, hotels, private security, etc

**DPS
CILINDROS PARA ELEVADOS
REQUISITOS DE SEGURIDAD**

Esta familia de cilindro cumple con los más altos requisitos de seguridad y durabilidad de la norma EN 1303

- Durabilidad Supera el nivel 6 de la norma EN1303
- Resistencia Fuego, puede equipar puertas cortafuegos
- Resistencia a la corrosión excede el grado C de la norma EN1303
- Seguridad de la llave , supera infinitamente el nivel 6 de la norma EN 1303 (norma exige 100.000 combinaciones diferentes) 1.000.000 son garantizados.
- Resistencia El ataque, supera largamente el nivel 2 de la norma EN 1303

Cilindro con características para su instalación en los edificios de elevados standards de seguridad : Instalaciones de seguridad, industria, educación, sanidad, hostelería, seguridad privada etc.

**CILINDRO FABRICADO NA ÁUSTRIA. CÓPIAS DE CHAVE FABRICADAS EM PORTUGAL /
CYLINDER MADE IN AUSTRIA. KEY COPIES MADE IN PORTUGAL /
CILINDRO FABRICADO EN AUSTRIA. COPIAS DE LLAVE HECHAS EN PORTUGAL.**

- A - Mola de compressão para pino de bloqueio / Spring for locking slider / Muelle de compresión del pasador de bloqueo.**
- B - Pino de bloqueio / Locking sliders / pasador de bloqueo.**
- C - Barra de controlo / Control bar / barra de control.**
- D - Side bar / Barra lateral / barra lateral.**
- E - controle Manipulação / Manipulation control / control de Manipulación .**
- F - Pino da faixa / Tracking pin / Seguimiento de pin.**
- G - Proteção de perfuração do corpo / Body drilling protection / Protección de la perforación del cuerpo.**
- H - Protecção anti brocagem Núcleo / Plug drilling protection / Protección anti taladro.**

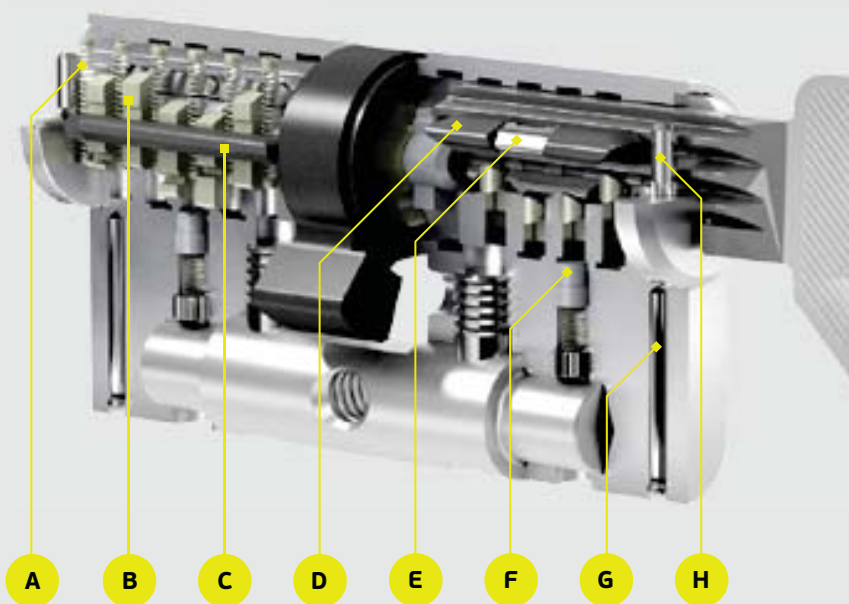

DPS - CILINDROS DE ALTA SEGURANÇA / DPS - HIGH SECURITY CYLINDERS / DPS - CILINDROS DE ALTA SEGURIDAD.

IN.19.DPS

CARACTERÍSTICAS:

Cilindro de perfil europeu, com 5 leitores de chave, 2 barras de leitura de perfil, Sistema antibrocagem multifacetado, cilindro modular, permite enorme variedade de tamanhos. Sistema de embraiagem que permite abertura pelo exterior mesmo com chave no interior.

Chave de obra opcional .

A maior gama disponível de botões para completa adequabilidade aos restantes elementos de fecho.

Chaves iguais e planos de mestragem sem limitações em numero e complexidade.

Perfis disponíveis : Europerfil, cilindro suíço, cilindro nórdico.

FEATURES:

European profile cylinder, with 5 key readers, 2 contour reading bar, Multifaceted anti-drill system, modular cylinder, allows huge variety of sizes. System clutch that allows opening the outside even with key inside.

Optional construction key.

The greater range of available buttons .Suitability to reach the design of other closure elements.

Keys alike and master key plans without limitation in number and complexity. Profiles available: Europerfil, Swiss cylinder, Nordic cylinder.

CARACTERÍSTICAS:

Cilindro de perfil europeu, con 5 lectores de llave, 2 barras de lectura de contorno, Sistema antitaladro multifacetado, cilindro modular, permite gran variedad de tamaños. Sistema de embrague que permite la apertura al exterior, incluso con llave en el interior.

Clave de obra opcional.

La mayor gama de botones disponibles para adecuación completar los elementos de cierre restantes.

Llaves iguales y planes de maestramiento sin limitación en número y complejidad. Perfiles disponibles: Europerfil, cilindro suizo, cilindro nórdico.

IN.19.DPS.....B1



IN.19.DPS.....B2

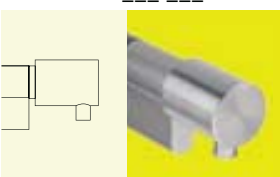

IN.19.DPS.....B3



IN.19.DPS.....B4

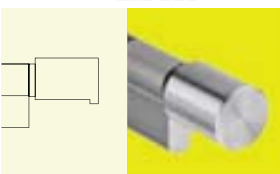

IN.19.DPS.....B5

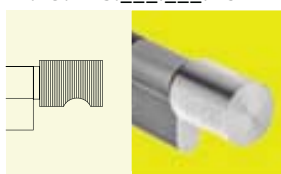

IN.19.DPS.....B6



Mestragem de cilindros (Anexar plano) /
Master key system
(Attach master key plan)/
Cilindros amaestrados
(Añadir plano de
amaestramiento)

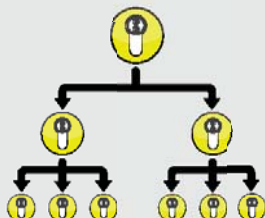

Grupos de chaves iguais (Anexar plano) /
Key alike group
(Attach plan) /
Grupos de llaves iguales
(Añadir plano).

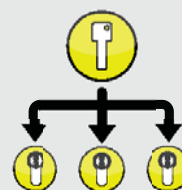



IN.19.DPS.____

Chaves diferentes /
Different key / Llaves distintas

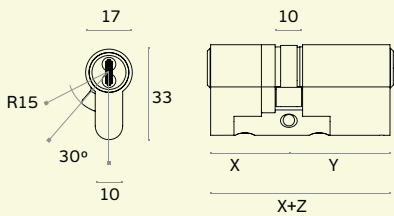

X	Y	X + Z
31	41	72
31	51	82
31	71	102
41	61	102
51	61	112

IN.19.DPS.____

Chaves diferentes /
Different key / Llaves distintas

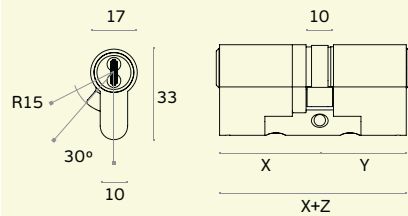

X	Y	X + Z
31	31	62
36	36	72
41	41	82
46	46	92
51	51	102
56	56	112
61	61	122

IN.19.DPS.____.11

Chaves diferentes /
Different key / Llaves distintas

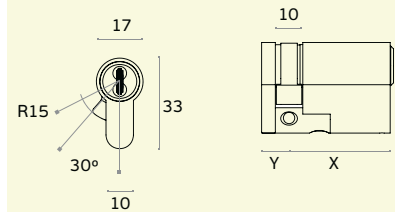

X	Y
41	11



S30 - CILINDROS DE ALTA SEGURANÇA /

S30 - HIGH SECURITY CYLINDERS /

S30 - CILINDROS DE ALTA SEGURIDAD.

S30 UMA CHAVE INOVADORA

Cilindro de segurança com perfil exclusivo JNF.
Perfil de chave patenteado.
Cilindro com 18 pinos, sendo 6 de leitura de perfil. Numero de combinaciones superior a 400.000.
Proteção anti-brocagem.
Sistema de dupla acção, funciona por ambos os lados mesmo com chave introduzida num deles.
Planos de mestragem simples até um máximo de 1000 cilindros. Extensão de plano não é possível.
Chave incopiável.

As cópias de chave são fabricadas e controladas exclusivamente pela JNF Portugal.

S30 A INOVATIVE KEY

Security cylinder with JNF exclusif profile.
Patented key profile.
Cylinder with 18 pins, 6 profile of readers .
Number of different key combinations up to 400.000
Anti-drill protection.
System double-acting work with key for both sides even with one inserted key.
Single master key plans up to 1000 cylinders.
Master key extension not possible.
Not possible to duplicate the key.

The copy keys are exclusively made and controlled by JNF Portugal.

S30 UNA LLAVE INOVADORA

Cilindro de seguridad con perfil JNF exclusivo.
Perfil de llave patenteado.
Cilindro con 18 pitones, 6 de lectura de perfil . Numero de combinaciones superior a 400.000.
Protección Anti-taladro
Sistema de doble embrague funciona por ambos os lados mesmo com uma llave introduzida en uno de ellos.
Maestramiento simple hasta 1000 cilindros.
Ampliacion de plan de cierre no es possible.
Llave Incopiáble

Copias de llave son fabricados y controlados exclusivamente por JNF Portugal

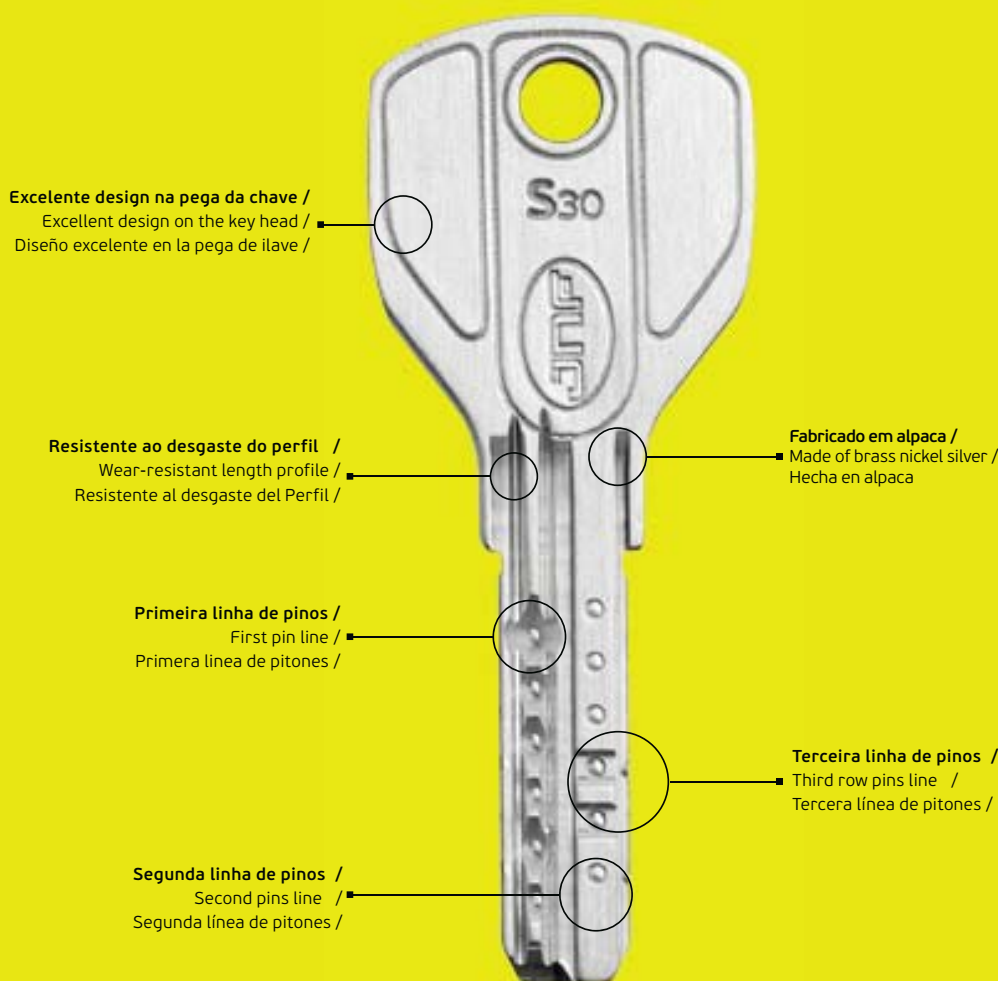

S30 CILINDROS DE SEGURANÇA

Esta família de cilindros satisfaz níveis médios de segurança e durabilidade da norma EN 1303

- Durabilidade ultrapassa largamente o grau 6 da norma EN1303
 - Resistência ao Fogo , pode equipar portas corta fogo
 - Resistência à corrosão , ultrapassa o Grau C da norma EN1303
 - Segurança da chave , ultrapassa infinitamente o grau 6 da norma EN 1303 (norma exige 100.000 combinações diferentes)400.000 combinações.
 - Resistência ao ataque , ultrapassa largamente o grau 2 da norma EN 1303
- Cilindro com características para padrões médios de segurança: industria, ensino, saúde, hotelaria, segurança privada etc.

S30 SECURITY CYLINDERS

This cylinder family meets medium safety and durability requirements of EN 1303

- Durability Far exceeds the level 6 of standard EN1303
 - Resistance Fire, can equip fire proof doors
 - Resistance Corrosion exceeds the Grade C of the standard EN1303
 - Security Key, infinitely surpasses the level 6 of EN 1303 (standard requires 100,000 different combinations) 400.000 combinations is reached.
 - Resistance The attack, far exceeds the level 2 of EN 1303
- Cylinder with features for installation in buildings of medium security standards: industry, education, healthcare, hotels, private security ,etc

S30 CILINDROS PARA LOS REQUISITOS DE SEGURIDAD MEDIOS

Esta familia de cilindro cumple con los requisitos medios de seguridad y durabilidad de la norma EN 1303

- Durabilidad Supera el nivel 6 de la norma EN1303
 - Resistencia Fuego, puede equipar puertas cortafuegos
 - Resistencia a la corrosión excede el grado C de la norma EN1303
 - Seguridad de la llave , supera infinitamente el nivel 6 de la norma EN 1303 (norma exige 100.000 combinaciones diferentes) 400.000 son garantizados.
 - Resistencia El ataque, supera largamente el nivel 2 de la norma EN 1303
- Cilindro con características para su instalación en los edificios con estándares medios de seguridad: industria, educación, sanidad, hosteleria, seguridad privada,etc.

A - Rotor / Cam / Rotor.

B - Protecção anti brocagem do rotor /
Anti-drill / Protección anti taladro.

C - 12 Pinos de leitura de perfil. /
12 profile pins. / 12 pines de leitura.

D - 6 Pinos / 6 Pins / 6 Pines de cierre.

E - Protecção anti brocagem /
Anti-drill / Protección anti taladro.

F - Mola / Spring / Muelle.

G - Pinos anti gazua /
No-picking pins / protección antigazua.

H - Corpo do Cilindro /
Cylinder body / Cuerpo del cilindro.

I - Palhetão com embreagem/
Cam with gear / Lleva con embrague.

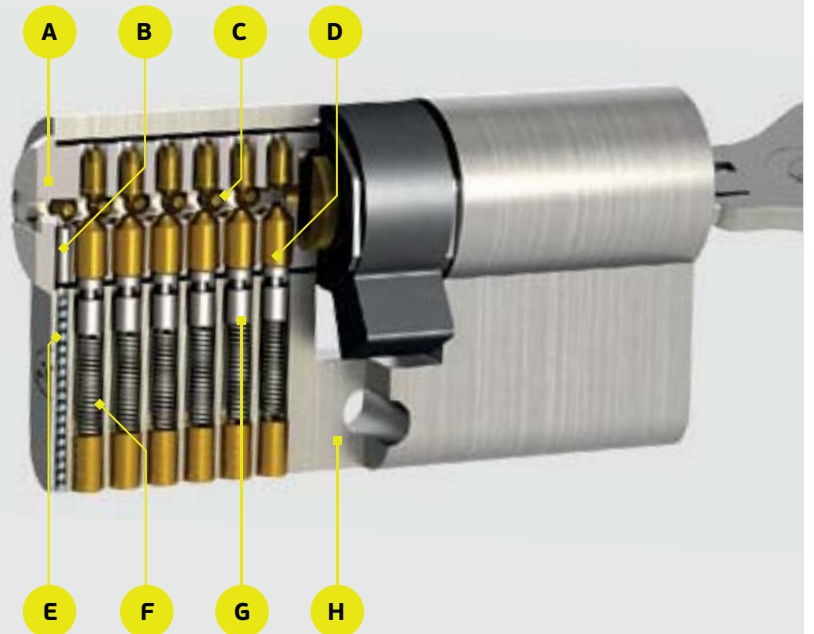

Cartão de proprietário /
Card Owner / Tarjeta de propietario.

S30 - CILINDROS DE ALTA SEGURANÇA / S30 - HIGH SECURITY CYLINDERS / S30 - CILINDROS DE ALTA SEGURIDAD.

S30

Características:

Cilindro de perfil europeu, com 18 leitores de chave, 6 controladores de leitura de perfil.

Sistema antibrocagem. Sistema de embraiagem que permite abertura pelo exterior mesmo com chave no interior.

A maior gama disponível de botões para completa adequabilidade aos restantes elementos de fecho.

Chaves iguais e planos de mestragem limitado a 1000 cilindros.

Extensões não possíveis.

Perfis disponíveis: Europerfil.

Features:

European profile cylinder, with 18 key readers, 6 profile readers.

Anti-drill system, System clutch that allows opening the outside even with key inside.

The greater range of available buttons

.Suitability to reach the design of other closure elements.

Keys alike and master key plans with maximum number of 1000 cylinders.

Extensions not possible.

Profiles available: Europerfil.

Características:

Cilindro de perfil europeu, com 18 leitores de chave, 6 pitones de leitura de contorno, Sistema antitaladro. Sistema de embraiagem que permite la abertura al exterior, incluso con llave en el interior.

La mayor gama de botones disponibles para adecuación completar los elementos de cierre restantes.

Llaves iguales y planes de maestramiento limitados a 1000 cilindros.

Ampliaciones no posibles.

Perfiles disponibles: Europerfil.

IN.19.S30.____.____

Chaves diferentes /

Different key / Llaves distintas

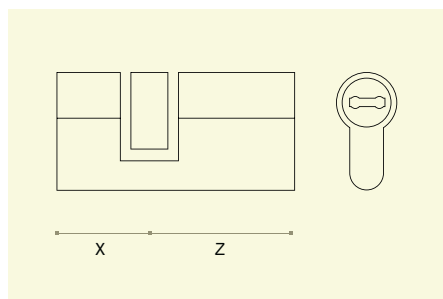

X	Z	X + Z
31,5	40	71,5
31,5	50	81,5
40	50	90
31,5	60	91,5

IN.19.S30.____.____

Chaves diferentes /

Different key / Llaves distintas

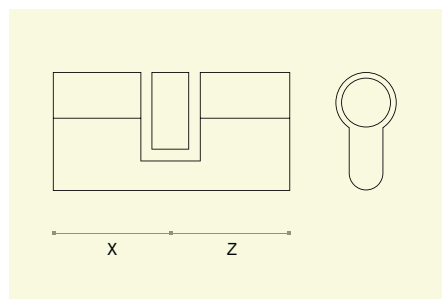

X	Z	X + Z
31,5	31,5	63
32,5	32,5	65
35	35	70
40	40	80

Ampliação de planos de mestragem não é possível /
Extension of existing master key not possible /
Ampliacion de plan de cierre no és possible.

Mestragem de cilindros (Anexar plano) /
Master key system
(Attach master key plan)/
Cilindros amaestrados
(Añadir plano de amaestramiento)

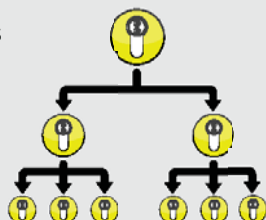

Grupos de chaves iguais (Anexar plano) /
Key alike group
(Attach plan) /
Grupos de llaves iguales
(Añadir plano).

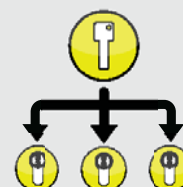



IN.19.S30.____

Mestragens simples / Single master key system / Amaestramiento sencillo.

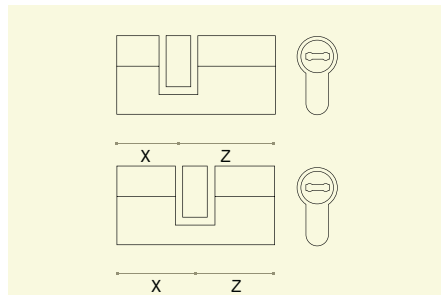

Y	Z	X + Z
31,5	31,5	63
32,5	32,5	65
35	35	70
31,5	40	71,5
40	50	90

IN.19.S30.____

Chaves iguais / Key alike / Llaves iguales.

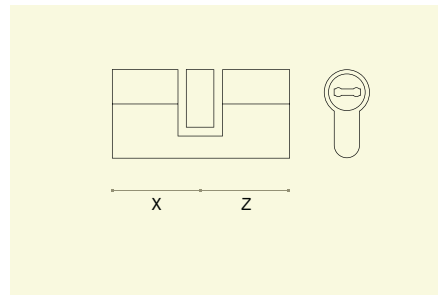

X	Z	X + Z
31,5	31,5	63
31,5	40	71,5

IN.19.S30.____.11

Grupos / Groups.

2K	2 cilindros / 2 cylinders / 2 cilindros.
4K	4 cilindros / 4 cylinders / 4 cilindros.
10K	10 cilindros / 10 cylinders / 10 cilindros.



S22 - CILINDROS DE SEGURANÇA /

S22 - SECURITY CYLINDERS /

S22 - CILINDROS DE SEGURIDAD.

S22

SISTEMA DE CODIFICAÇÃO INTERNA

O SISTEMA DE CHAVE SIMÉTRICA (REVERSÍVEL) PARA REQUISITOS DE SEGURANÇA MÉDIA.

- CHAVES CODIFICADAS.
- CARTÃO DE PROPRIETÁRIO.
- PROTEÇÃO ANTI BROCAJEM.
- ANTI GAZUA.
- FORNECIDO COM 5 CHAVES.
- POSSIBILIDADE DE GRUPOS DE CHAVES IGUAIS
- POSSIBILIDADE DE MESTRAGEM (S28)

S22

INTERNAL CODIFICATION SYSTEM

THE REVERSIBLE KEY SYSTEM FOR MEDIUM SECURITY REQUIREMENTS AND TOUGHEST CONDITIONS.

- ENCODED KEYS.
- PROPERTY CARD.
- ANTI DRILL PROTECTION
- ANTI PICKING PROTECTION
- SUPPLIED WITH 5 KEYS
- POSSIBLE TO HAVE KEY ALIKED GROUPS
- POSSIBLE TO MAKE MASTER KEY (S28)

S22

SISTEMA DE CODIFICATION INTERNA

LLAVE SIMETRICA (REVERSIBLE) PARA REQUISITOS DE SEGURIDADE MEDIOS.

- LLAVES CODIFICADAS.
- TARJETA DE PROPIETARIO
- PROTECCIÓN ANTI TALADRO
- PROTECCIÓN ANTI GAZUA
- SUMINISTRADO CON 5 LLAVES
- POSSIBLE DE TENER GRUPOS DE LLAVES IGUALADAS
- POSSIBLE DE TENER SISTEMA DE LLAVE MAESTRA (S28)

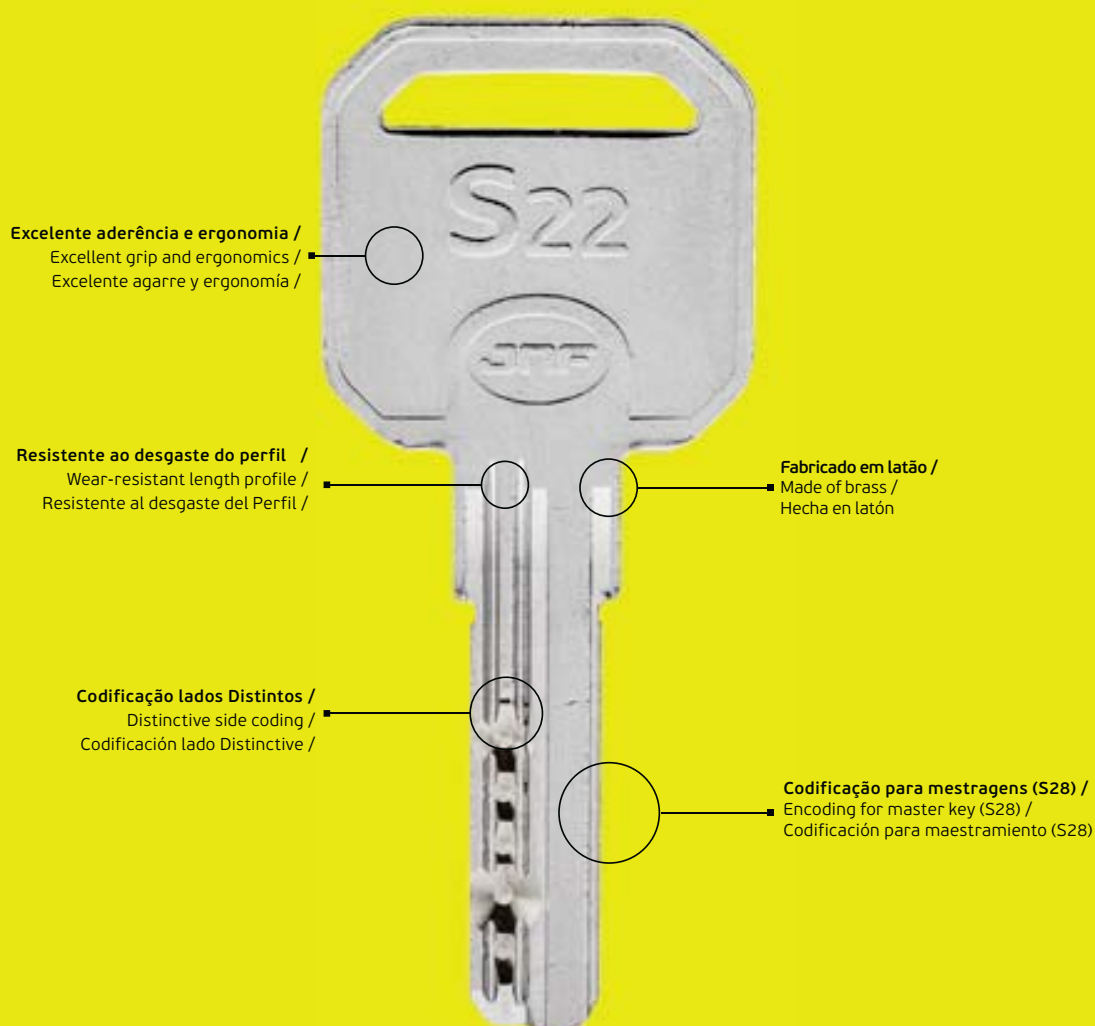

S22
CILINDROS DE SEGURANÇA /

S22
SECURITY CYLINDERS /

S22
CILINDROS DE SEGURIDAD.

- A - Corpo do Cilindro /**
Cylinder body / Cuerpo del cilindro
- B - Protecção anti brocagem /**
Anti-drill / Protección anti taladro.
- C - Rotor / Cam / Rotor.**
- D - Pinos / Pins / Pines de cierre**

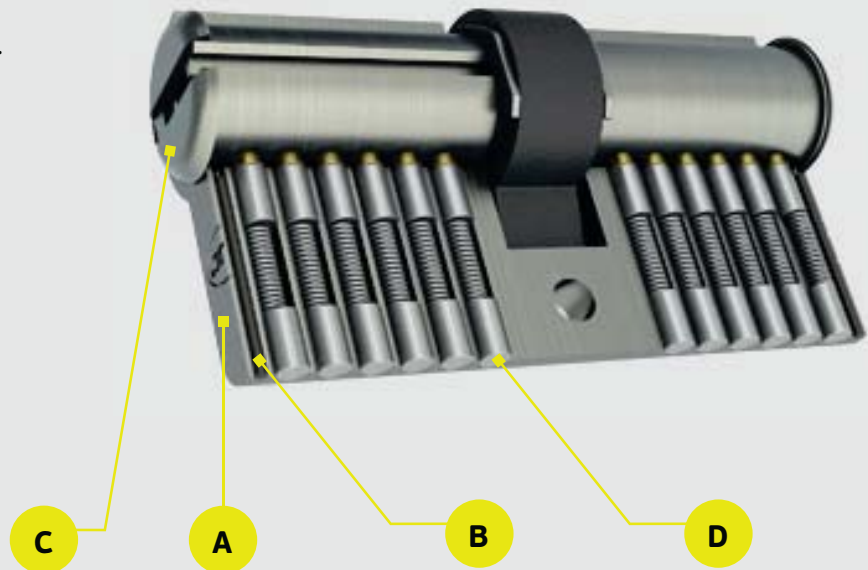

Cartão de proprietário /
Card Owner / Tarjeta de propietario.

S22 - CILINDROS DE SEGURANÇA / S22 - SECURITY CYLINDERS / S22 - CILINDROS DE SEGURIDAD.

S22

Cilindro de Perfil Europeu de Segurança com 6 Pinos, protecção anti brocagem e anti gazua. Disponível em grupos de chaves iguais. Fornecido com 5 chaves numeradas e cartão de propriedade para realização de copias de chaves. Acabamento em Niquel Escovado.

Security Cylinder of European Profile with 6 Pins, anti-drill and anti picking protection. Available with key alike groups. Supplied with 5 numbered keys and property card for duplication of cylinder keys. Finish in satin nickel.

Cilindro de Seguridad de Perfil Europeo con 6 pines, protección anti gazua y anti taladro. Disponible en grupos de llave iguales. Suministrado con 5 llaves numeradas y tarjeta de propiedad para duplicación de llaves. Acabado : Niquel Mate.

IN.19.S22._._ Chaves diferentes / Different key / Llaves distintas

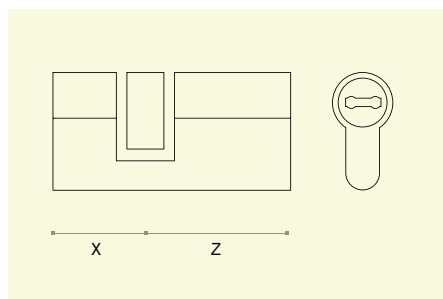

X	Z	X + Z
31,5	40	71,5
31,5	50	81,5
40	50	90
31,5	60	91,5

IN.19.S22._._ Chaves diferentes / Different key / Llaves distintas

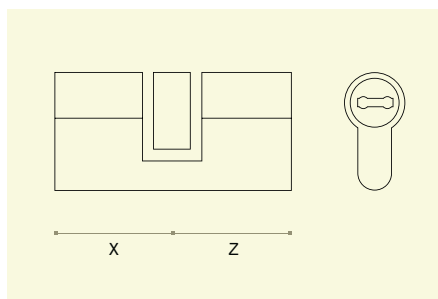

X	Z	X + Z
31,5	31,5	63
32,5	32,5	65
35	35	70
40	40	80

Ampliação de planos de mestragem não é possível /
Extension of existing master key not possible /
Ampliacion de plan de cierre no és possible.

S28
Mestragem de cilindros
(Anexar plano) /
Master key system
(Attach master key plan)/
Cilindros amaestrados
(Añadir plano de
amaestramiento)

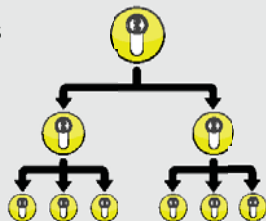

Grupos de chaves
iguais (Anexar plano) /
Key alike group
(Attach plan) /
Grupos de llaves iguales
(Añadir plano).

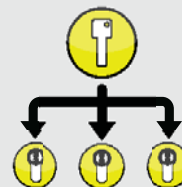



IN.19.S28......

Mestragens simples / Single master key system / Amaestramiento sincillo.

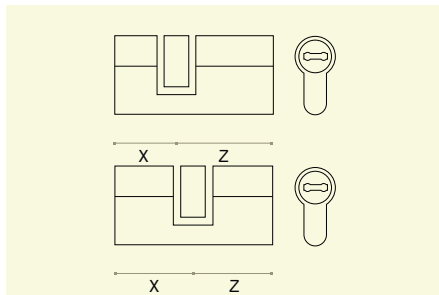

Y	Z	X + Z
31,5	31,5	63
32,5	32,5	65
35	35	70
31,5	40	71,5
40	50	90

IN.19.S22......

Chaves iguais / Key alike / Llaves iguales.

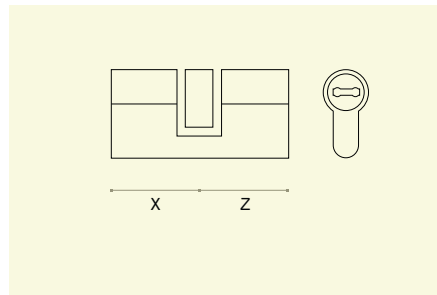

X	Z	X + Z
31,5	31,5	63
31,5	40	71,5

IN.19.S22......11

Grupos / Groups.

2K	2 cilindros / 2 cylinders / 2 cilindros.
4K	4 cilindros / 4 cylinders / 4 cilindros.
10K	10 cilindros / 10 cylinders / 10 cilindros.



S20 - CILINDROS DE SEGURANÇA /

S20 - SECURITY CYLINDERS /

S20 - CILINDROS DE SEGURIDAD.

S20

SISTEMA DE CODIFICAÇÃO INTERNA

O SISTEMA DE CHAVE SIMÉTRICA (REVERSÍVEL) PARA REQUISITOS DE SEGURANÇA MÉDIA.

- CHAVES CODIFICADAS.
- CARTÃO DE PROPRIETÁRIO.
- PROTEÇÃO ANTI BROCAJEM.
- ANTI GAZUA.
- FORNECIDO COM 5 CHAVES.
- POSSIBILIDADE DE GRUPOS DE CHAVES IGUAIS

S20

INTERNAL CODIFICATION SYSTEM

THE REVERSIBLE KEY SYSTEM FOR MEDIUM SECURITY REQUIREMENTS AND TOUGHEST CONDITIONS.

- ENCODED KEYS.
- PROPERTY CARD.
- ANTI DRILL PROTECTION
- ANTI PICKING PROTECTION
- SUPPLIED WITH 5 KEYS
- POSSIBLE TO HAVE KEY ALIKED GROUPS

S20

SISTEMA DE CODIFICATION INTERNA

LLAVE SIMETRICA (REVERSIBLE) PARA REQUISITOS DE SEGURIDADE MEDIOS.

- LLAVES CODIFICADAS.
- TARJETA DE PROPIETARIO
- PROTECCIÓN ANTI TALADRO
- PROTECCIÓN ANTI GAZUA
- SUMINISTRADO CON 5 LLAVES
- POSSIBLE DE TENER GRUPOS DE LLAVES IGUALADAS



S20
CILINDROS DE SEGURANÇA /

S20
SECURITY CYLINDERS /

S20
CILINDROS DE SEGURIDAD.

- A - Corpo do Cilindro /**
Cylinder body / Cuerpo del cilindro
- B - Protecção anti brocagem /**
Anti-drill / Protección anti taladro.
- C - Rotor / Cam / Rotor.**
- D - Pinos / Pins / Pines de cierre**

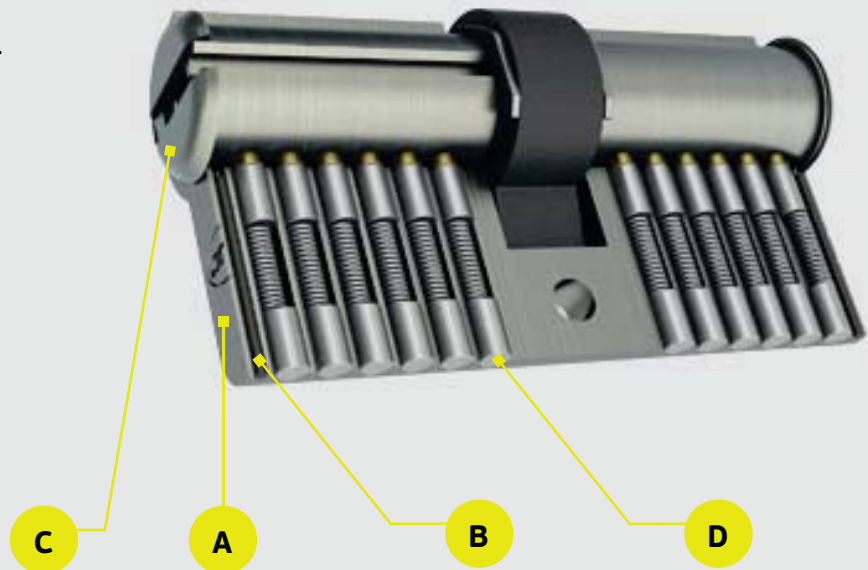

Cartão de proprietário /
Card Owner / Tarjeta de propietario.

S20 - CILINDROS DE SEGURANÇA / S20 - SECURITY CYLINDERS / S20 - CILINDROS DE SEGURIDAD.

IN.19.524

Cilindro de Perfil Europeu de Segurança com 6 Pinos, protecção anti brocagem e anti gazua. Disponível em grupos de chaves iguais. Fornecido com 5 chaves numeradas e cartão de propriedade para realização de copias de chaves. Acabamento em Niquel Escovado.

Security Cylinder of European Profile with 6 Pins, anti-drill and anti picking protection. Available with key alike groups. Supplied with 5 numbered keys and property card for duplication of cylinder keys. Finish in satin nickel.

Cilindro de Seguridad de Perfil Europeo con 6 pines, protección anti gazua y anti taladro. Disponible en grupos de llave iguales. Suministrado con 5 llaves numeradas y tarjeta de propiedad para duplicación de llaves. Acabado : Niquel Mate.

IN.19.524._._ Chaves diferentes / Different key / Llaves distintas

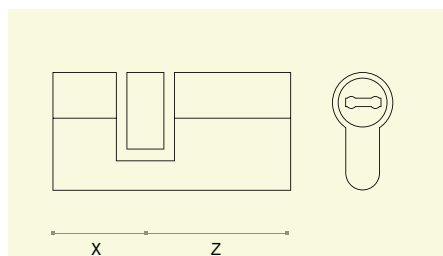

X	Z	X + Z
31,5	35	66,5
31,5	40	71,5
31,5	50	81,5

IN.19.524._._ Chaves diferentes / Different key / Llaves distintas

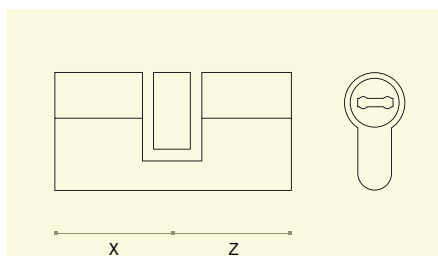

X	Z	X + Z
31,5	31,5	63
32,5	32,5	65
35	35	70
40	40	80

IN.19.524.10._ Chaves diferentes / Different key / Llaves distintas

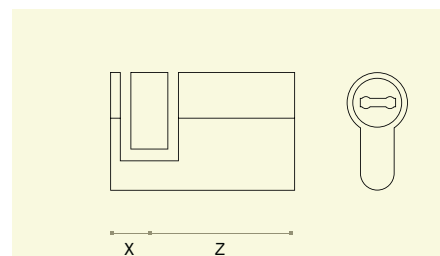

X	Z	X + Z
10	31,5	41,5
10	35	45
10	40	50

Ampliação de planos de mestragem não é possível /
Extension of existing master key not possible /
Ampliacion de plan de cierre no és possible.

Mestragem de cilindros (Anexar plano) /
Master key system
(Attach master key plan)/
Cilindros amaestrados
(Añadir plano de amaestramiento)

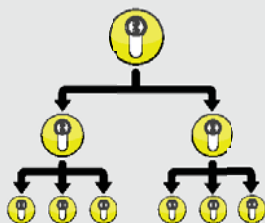

Grupos de chaves iguais (Anexar plano) /
Key alike group
(Attach plan) /
Grupos de llaves iguales
(Añadir plano).

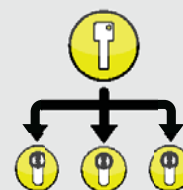



IN.19.524._._.K
Chaves iguais /
Key alike / Llaves iguales.

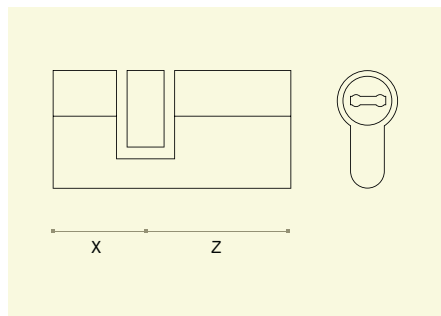

X	Z	X + Z
31,5	35	66,5
31,5	40	71,5
31,5	50	81,5

IN.19.524._._.K
Chaves iguais /
Key alike / Llaves iguales.

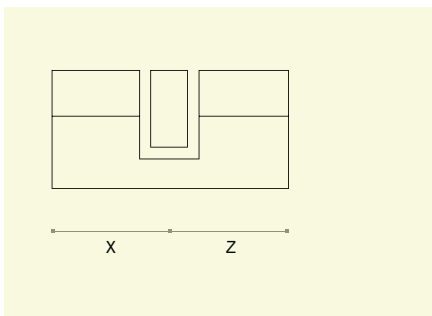

X	Z	X + Z
31,5	31,5	63
32,5	32,5	65
35	35	70
40	40	80

Grupos /
Groups.

2K	2 cilindros / 2 cylinders / 2 cilindros.
12K	12 cilindros / 12 cylinders / 12 cilindros.



S20 - CILINDROS DE SEGURANÇA / S20 - SECURITY CYLINDERS / S20 - CILINDROS DE SEGURIDAD.

IN.19.524.B2

Cilindro de Perfil Europeu de Segurança de botão em aço inox, 6 modelos disponíveis. Protecção anti brocagem e anti gazua. Fornecido com 5 chaves numeradas e cartão de propriedade para realização de cópias de chaves. Acabamento em Níquel Escovado. /

Security Cylinder of European Profile with stainless steel button, 6 models available. Anti-drill and anti picking protection. Supplied with 5 numbered keys and property card for duplication of cylinder keys. Finish in satin nickel./

Cilindro de Seguridad de Perfil Europeo con botón en acero inoxidable, 6 modelos disponibles. Protección anti gazua e anti taladro. Suministrado con 5 llaves numeradas y tarjeta de propiedad para duplicación de llaves. Acabado : Níquel Mate.

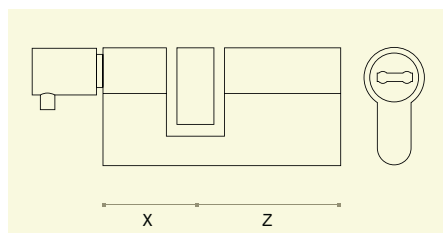

X	Z	X + Z
31,5	40	71,5

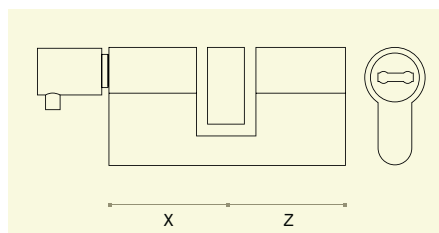

X	Z	X + Z
31,5	31,5	63
35	35	70
45	55	95

IN.19.524.....B1
IN.19.526.....B1



IN.19.524.....B2
IN.19.526.....B2

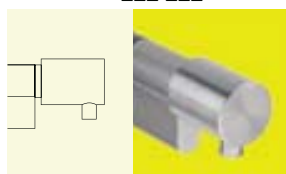

Botões opcionais /
Optionals knobs /
pomos opcionales

IN.19.524.....B3
IN.19.526.....B3



IN.19.524.....B4
IN.19.526.....B4



IN.19.524.....B5
IN.19.526.....B5

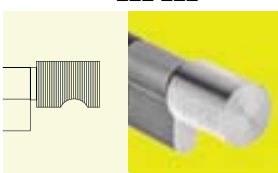

IN.19.524.....B6
IN.19.526.....B6



IN.19.526.B2

Cilindro de Perfil Europeu com fenda para moeda de um lado e botão em aço inox do outro, 6 modelos disponíveis. /

Cylinder of European Profile with coin slot in one side, and stainless steel button in opposite side, 6 models available /

Cilindro de Perfil Europeo con fenda para moneda en un lado, y botón en acero inoxidable por el otro, 6 modelos disponibles.

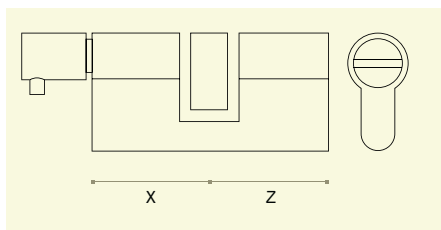

X	Z	X + Z
30	30	60

IN.19.527.B

Cilindro de Perfil Europeu com botão ergonómico e fenda para moeda. Produzido em liga de zinco. Acabamento em Níquel Escovado. /

Cylinder of European Profile with ergonomic button and coin slot. Made in zinc alloy. Finish in satin nickel./

Cilindro de Perfil Europeo con botón ergonómico y fenda para moneda. Fabricado en aleación de zinco. Acabado Níquel Mate.



NEW

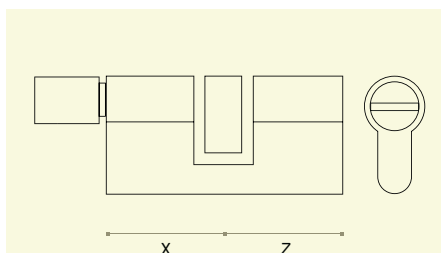

X	Z	X + Z
32,5	32,5	65

S10 - CILINDRO EUROPEU / S10 - EUROPEAN CYLINDER / S10 - CILINDRO EUROPEO

IN.19.523.0

Cilindro de Perfil Europeu com 6 Pinos, protecção anti brocagem e anti gazua. Disponível em grupos de chaves iguais e mestragens simples. Fornecido com 3 chaves.

Acabamento em Niquel Escovado. /

European profile cylinder with 6 Pins, anti-drill and anti picking protection. Available with key alike groups and Single master key system. Supplied with 3 keys. Finish in satin nickel./

Cilindro de Perfil Europeu con 6 pinos, protección anti gazua y anti taladro. Disponible en grupos de llave iguales y amaestramiento sencillo. Suministrado con 3 llaves. Acabado : Niquel Mate.



IN.19.523.C

Chave em bruto /

Blank Key /

Llave en bruto.



IN.19.523._._

Chaves diferentes /

Different key / Llaves distintas

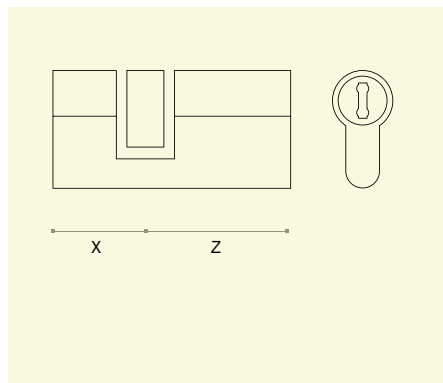

X	Z	X + Z
30	35	65
30	40	70

IN.19.523._._

Chaves diferentes /

Different key / Llaves distintas

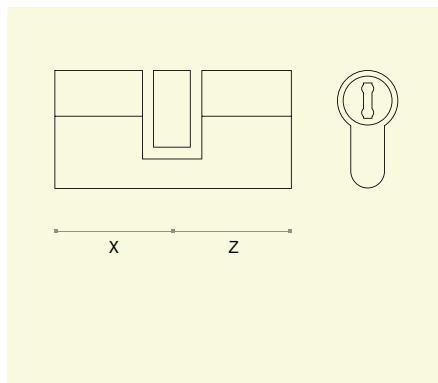

X	Z	X + Z
30	30	60
35	35	70
40	40	80

IN.19.523.10._

Chaves diferentes /

Different key / Llaves distintas

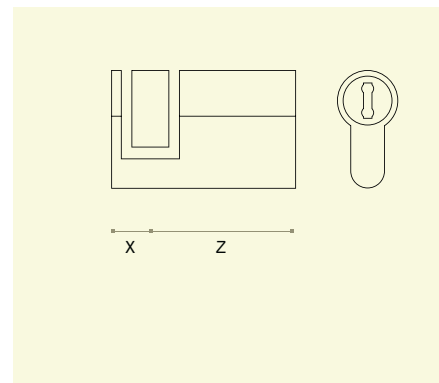

X	Z	X + Z
10	31,5	41,5
10	35	45
10	40	50

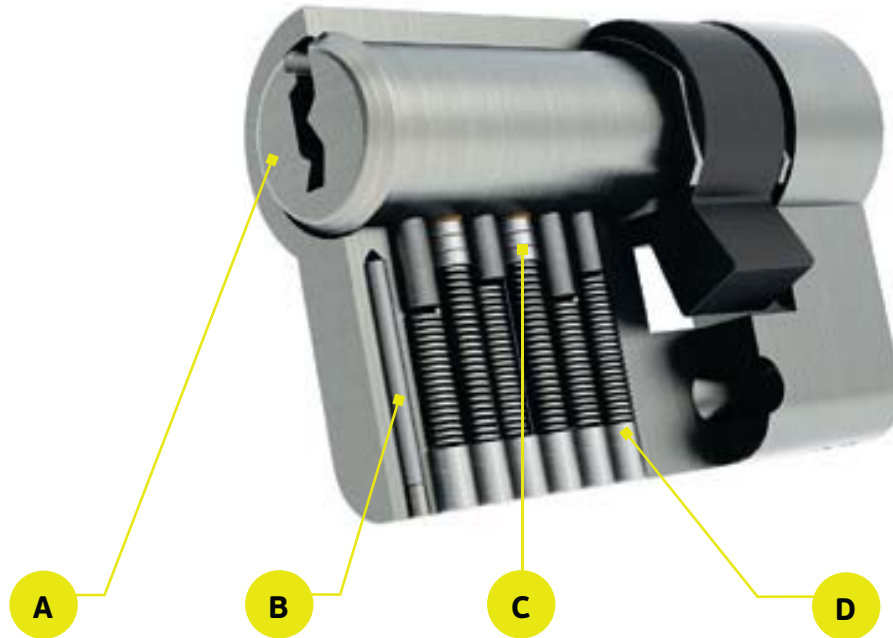

Grupos de chaves iguais (Anexar plano) /
Key alike group
(Atach plan) /
Grupos de llaves iguales
(Añadir plano).

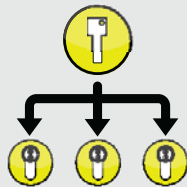

A - Corpo do cilindro /
cylinder body / Cuerpo del cilindro
B - Protecção anti brocagem /
Cuerpo del cilindro / Cuerpo del cilindro
C - Pinos de mestragem / Master key pins /
Pitons de amaestramento.
D - 6 pinos / 6 pin / 6 pin.

IN.19.523.+ (Plano de mestragem)
Mestragens simples / Single master key
system / Amaestramento sincillo.

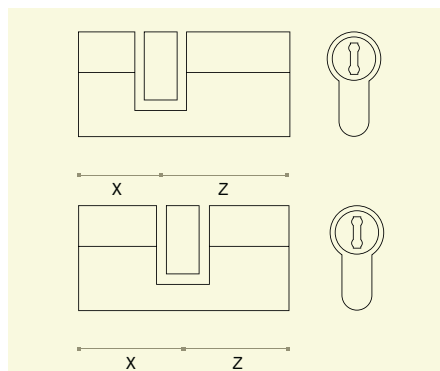

X	Y	X + Z
30	35	65
30	40	70
30	30	60
35	35	70
40	40	80

IN.19.523.30.30.__K
Chaves iguais /
Key alike / Llaves iguales.

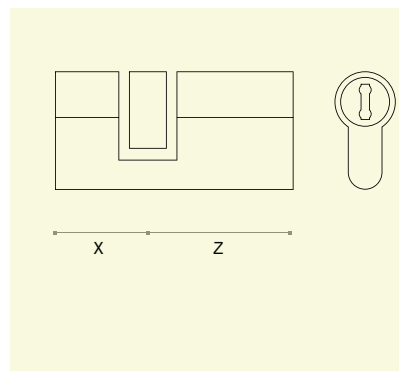

X	Y	X + Z
30	30	60
30	40	70
35	35	70
40	40	80

Grupos /
Groups.

2K	2 cilindros / cylinders / cilindros.
3K	3 cilindros / cylinders / cilindros.
4K	4 cilindros / cylinders / cilindros.
10K	10 cilindros / cylinders / cilindros.
20K	20 cilindros / cylinders / cilindros.
50K	50 cilindros / cylinders / cilindros.
100K	100 cilindros / cylinders / cilindros.

S10 - CILINDRO EUROPEU / S10 - EUROPEAN CYLINDER / S10 - CILINDRO EUROPEO

IN.19.523.B2

Cilindro de Perfil Europeu com botão em aço inox, 6 modelos disponíveis. Protecção anti brocagem e anti gazua. Fornecido com 3 chaves. Acabamento em Niquel Escovado. /

European profile cylinder with stainless steel button, 6 models available. Anti-drill and anti picking protection. Supplied with 3 keys. Finish in satin nickel./

Cilindro de perfil europeu con botón en acero inoxidable, 6 modelos disponibles. Protección anti gazua e anti taladro. Suministrado con 3 llaves. Acabado : Niquel Mate.

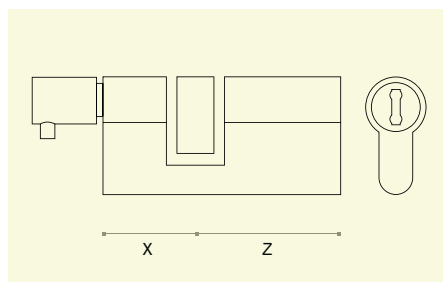

X	Z	X + Z
31,5	40	71,5

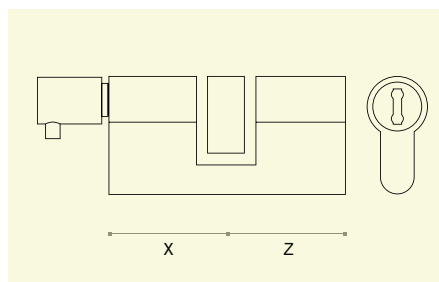

X	Z	X + Z
31,5	31,5	63
35	35	70



IN.19.523.....B1



IN.19.523.....B2

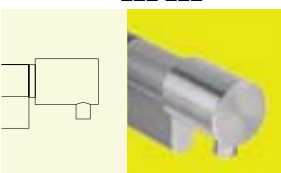

Botões opcionais /
Optionals knobs /
pomos opcionales

IN.19.523.....B3



IN.19.523.....B4



IN.19.523.....B5

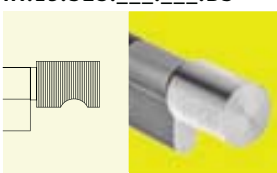

IN.19.523.....B6



S05 - CILINDRO EUROPEU / S05 - EUROPEAN CYLINDER / S05 - CILINDRO EUROPEO.

IN.19.S05

Cilindro de Perfil Europeu em latão com 5 pinos.
Acabamento em Niquel Escovado. /

European profile cylinder made in brass with 5 pins.
Finish in satin nickel./

Cilindro de Perfil Europeu en latón con 5 pinos.
Acabado Niquel Mate.

IN.19.S05.C

Chave em bruto /
Blank Key /
Llave en bruto.



NEW



IN.19.S05._._

Chaves diferentes /
Different key / Llaves distintas

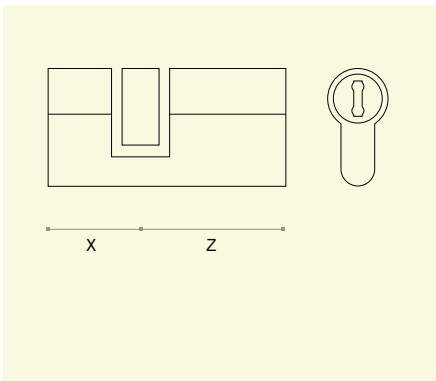

X	Z	X + Z
30	40	70

IN.19.S05._._

Chaves diferentes /
Different key / Llaves distintas

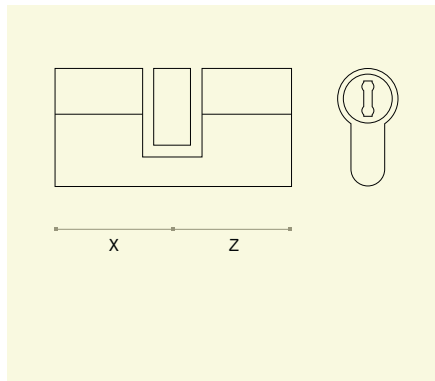

X	Z	X + Z
27,5	27,5	55
30	30	60
32,5	32,5	65
35	35	70



Acessórios e botões opcionais /
Accessories and optional knobs / Accesorios y pomos opcionales

IN.19.____.____.____.B1

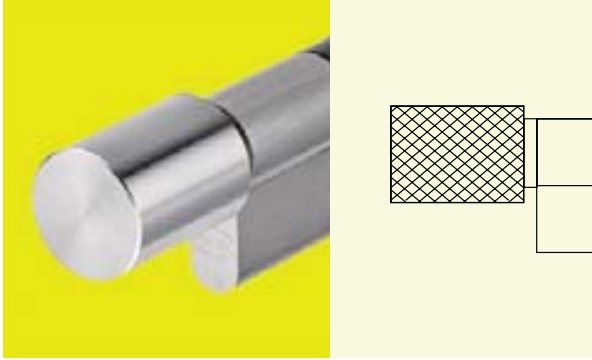

IN.19.____.____.____.B4

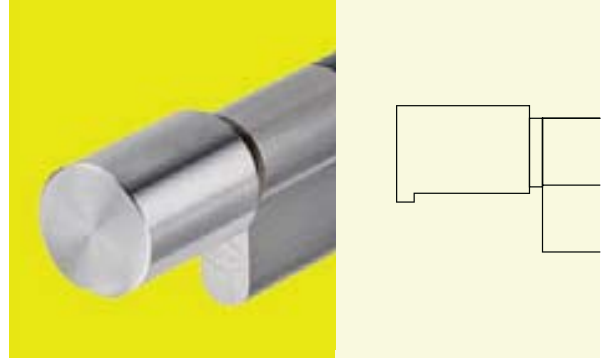

IN.19.____.____.____.B2

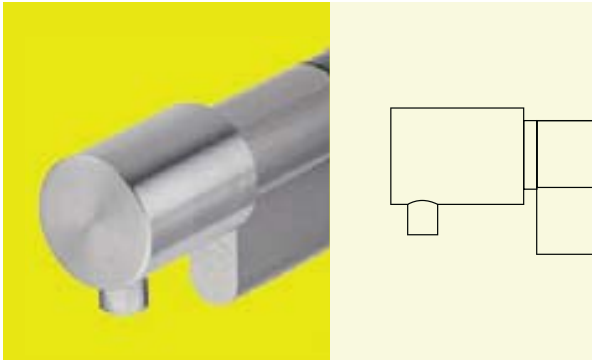

IN.19.____.____.____.B6

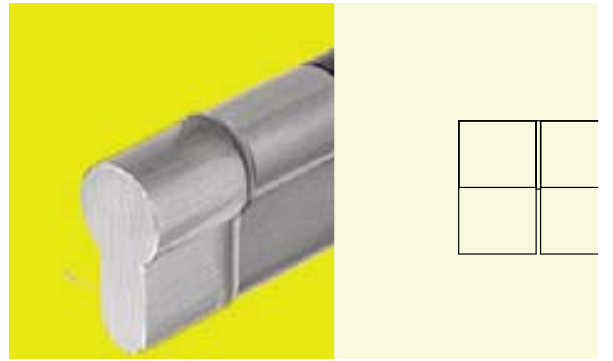

IN.19.____.____.____.B3

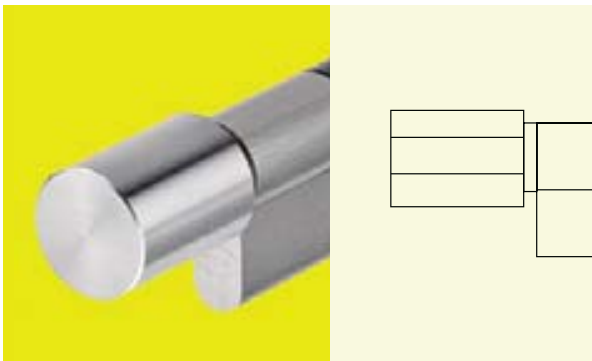

IN.19.____.____.____.B7

NEW



IN.19.S01

Cilindro cego / Blind cylinder / Cilindro ciego
Acabamento / Finish / Acabado : Niquel Mate.

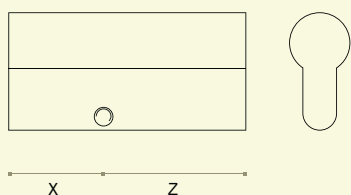

X	Z	X + Z
10	31,5	41.5
14.5	25	39.5
31.5	40	71.5

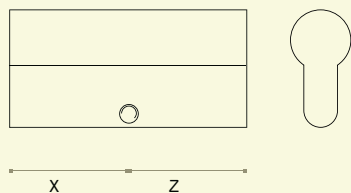

X	Z	X + Z
31.5	31,5	63
35	35	70
40	40	80

IN.19.S02

Cilindro para chave triangular /
Cylinder for triangular key / Cilindro para llave triangular
Acabamento / Finish / Acabado : Niquel Mate.

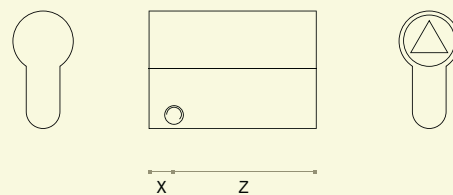

X	Z	X + Z
10	31.5	41.5

IN.19.S02.C

Chave triangular /
Triangular key / Llave triangular



DISPOSITIVOS ELECTROMAGNÉTICOS E ELECTROMECHANICOS / ELECTROMAGNETIC AND ELECTROMECHANICAL DEVICES / DISPOSITIVOS ELECTROMAGNETICOS Y ELECTROMECHANICOS.





Dispositivos Electromecánicos /
Electrified door hardware /
Dispositivos electromecánicos.



TESTAS ELÉCTRICAS/ ELECTRIC STRIKE / CERRADERO ELÉCTRICO.

Testa eléctrica reversível. Corrente de entrada 12Vac-Dc. Trinco ajustável 4mm. Possibilidade de funcionar em modo de passagem. Possibilidade de instalar em diferentes frentes de aço inoxidável.

Reversible electric strike. Power input 12 Vac-Dc. Adjustable latch 4mm. Possible to work in passage mode. Possibility to install in different stainless steel front plates.

Cerradero eléctrico reversible. Corriente de entrada 12 Vac-Dc. Cerradero regulable 4 mm. Capacidad para trabajar en modo de paso. Posibilidad de instalar en diferentes frentes de acero inoxidable.

A - Modo de passagem /

Passage mode / Modo de paso.

B - Função automática, permite deixar a porta aberta com um único e curto contacto eléctrico.

A porta volta a ficar fechada, quando alguém entra e fecha reativando de novo o dispositivo./

Delay action, allows the door staying open with one small and unique electric contact. The door stays closed till anyone goes inside and close the door reactivating the system. / Función automática permite dejar la puerta abierta con una única y corta alimentación eléctrica. La puerta vuelva estar cerrada solamente cuando alguien entra y cierra rearmando así el dispositivo.

C - Trinco ajustável 4mm/ Adjustable latch 4mm / Cerradero regulable 4 mm.

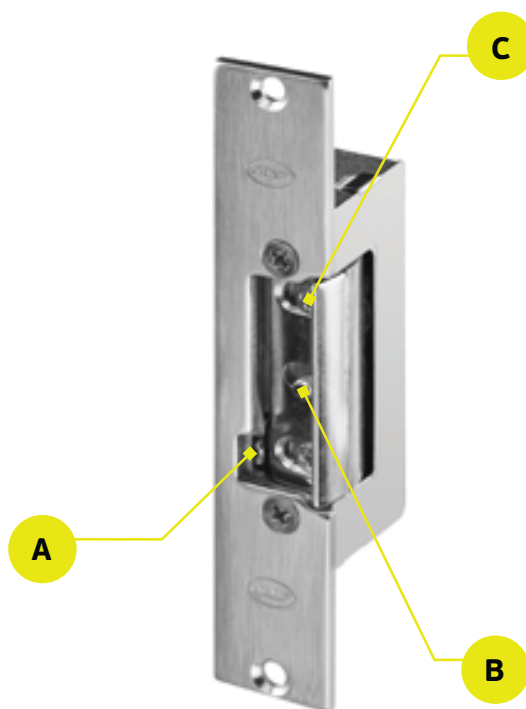

12 V

IN.20.650.A

Testa curta /
Short strike plate /
Cerradero corto.



IN.20.650.B

Testa longa para alumínio /
Long strike plate for
aluminium /
Cerradero largo para
aluminio.



IN.20.650.C

Testa longa /
Long strike plate /
Cerradero largo.



IN.20.650.D

Testa longa direita para
madeira /
Right long strike plate
for wood /
Cerradero derecho largo
para madera.



IN.20.650.E

Testa longa esquerda para
madeira /
Left long strike plate for
wood /
Cerradero izquierdo largo
para madera.



Testa eléctrica reversível com switch que monitoriza o estado da porta. Corrente de entrada 12/24 Vac-Dc. Trinco ajustável 4mm. Possibilidade de instalar em diferentes frentes de aço inoxidável. /

Reversible electric strike with switch that check the status of the door. Power input 12/24 Vac-Dc. Adjustable latch 4mm. Possibility to install in different stainless steel front plates. /
Cerradero eléctrico reversible con switch que controla el estado de la puerta. Corriente de entrada 12/24 Vac-Dc. Cerradero regulable 4 mm. Posibilidad de instalar en diferentes frentes de acero inoxidable.

A - Switch, monitoriza o estado da porta. Aberta ou fechada. / Switch, Check the status of the door. Open or closed. /
Switch, controla el estado de la puerta. Aperta o cerrada. /
B - Trinco ajustável 4mm/ Adjustable latch 4mm /
Cerradero regulable 4 mm.

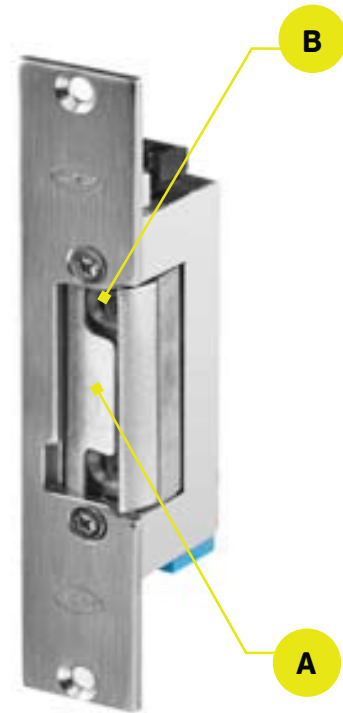

IN.20.651.A
Testa curta /
Short strike plate /
Cerradero corto.



IN.20.651.B
Testa longa para alumínio /
Long strike plate for
aluminium /
Cerradero largo para
aluminio.



IN.20.651.C
Testa longa /
Long strike plate /
Cerradero largo.



IN.20.651.D
Testa longa direita para
madeira /
Right long strike plate for
wood /
Cerradero derecho largo
para madera.



IN.20.651.E
Testa longa esquerda para
madeira /
Left long strike plate for
wood /
Cerradero izquierdo largo
para madera.



TESTAS ELÉCTRICAS/ ELECTRIC STRIKE / CERRADERO ELÉCTRICO

Testa eléctrica reversível corta-fogo.

Corrente de entrada 12 Vac-Dc.

Possibilidade de instalar em diferentes frentes de aço inoxidável /

Reversible fire proof electric strike. Power input 12 Vac-Dc. Possibility to install in different stainless steel front plates /

Cerradero eléctrico reversible corta fuego. Corriente de entrada 12 Vac-Dc.

Posibilidad de instalar en diferentes frentes de acero inoxidable.



12 V



IN.20.652.A

Testa curta /
Short strike plate /
Cerradero corto.



IN.20.652.B

Testa longa para alumínio /
Long strike plate for
aluminium /
Cerradero largo para
aluminio.



IN.20.652.C

Testa longa /
Long strike plate /
Cerradero largo.



IN.20.652.D

Testa longa direita para
madeira /
Right long strike plate for
wood /
Cerradero derecho largo
para madera.



IN.20.652.E

Testa longa esquerda para
madeira /
Left long strike plate for
wood /
Cerradero izquierdo largo
para madera.





■
Testas eléctricas/
Electric strike /
Cerradero eléctrico.



DISPOSITIVOS ELECTROMAGNÉTICOS / ELECTROMAGNETIC DEVICES / DISPOSITIVOS ELECTROMAGNETICOS.

**As fechaduras JNF
electromagnéticas são
adequadas para portas
interiores, portas de
saída ou de entrada, que
requerem libertação de
emergência e sistemas de
controlo de acesso.
Por não possuírem
componentes móveis,
permitem um desbloqueio
instantâneo, provocado
por um sinal do centro
detenção de incêndios,
controle remoto ou
controlo de acesso.**

ELECTROMAGNETIC LOCK IS SUITED
FOR INTERIOR DOORS, EXIT OR
ENTRANCE DOORS, THAT REQUIRE
FAIL SAFE EMERGENCY RELEASE
CAPABILITY AND ACCESS CONTROL
SYSTEMS.

WITH NO MOVING PARTS TO
BIND OR WEAR OUT, THE JNF
ELECTROMAGNETIC DOOR LOCKS
PROVIDE POSITIVE, INSTANTANEOUS
RELEASE, WHETHER CAUSED BY A
SIGNAL FROM THE FIRE COMMAND
CENTER, REMOTE CONTROL OR ACCESS
CONTROL.

LAS CERRADURAS
ELECTROMAGNÉTICAS JNF SON
ADECUADAS PARA PUERTAS
INTERIORES, PUERTAS DE SALIDA
O DE ENTRADAS QUE REQUIEREN
LIBERACIÓN DE EMERGENCIA Y
SISTEMAS DE CONTROL DE ACCESO.
POR NO TENEREM PIEZAS MÓVILES
PERMITEN UNA LIBERACIÓN
INSTANTÁNEA, DESENCADENADA
POR UNA SEÑAL PROCEDENTE DE
LOS CENTROS DE DETENCIÓN DE
INCENDIOS, EL MANDO A DISTANCIA O





DISPOSITIVOS ELECTROMAGNÉTICOS / ELECTROMAGNETIC DEVICES / DISPOSITIVOS ELECTROMAGNETICOS.



EN 50081-1/1992:EN 55014
EN 500 82-1/1997: EN 55015-2

12 V

24 V

LED

500
Kg5
years

IN.28.690

FECHADURA ELETROMAGNÉTICA

- Corpo em alumínio anodizado
- Sem magnetismo residual
- Força de retenção de 500 kg
- Baixo consumo de 0,7A para 12 VDC e 0,35A para 24 VDC
- LED para controle de posição da porta
- Tratamento Anti-corrosão
- Aplicável em temperaturas de -60 a +80 °C
- Projetado para alimentação de 12 V ou 24 V DC
- Disponíveis vários acessórios de fixação.

ELECTROMAGNETIC LOCK

- Body made in anodized aluminum
- No residual magnetism
- Holding force of 500 kg
- Low consumption 0,7A for 12 VDC and 0,35A for 24 VDC
- Led light for door control
- Anti-corrosion protected
- Suitable for temperatures between -60 and +80°C
- Designed for connection to 12 V or 24 V DC supplies
- available several different fixing accessories

CERRADURA ELECTROMAGNÉTICA

- Cuerpo en aluminio anodizado
- Sin magnetismo residual
- Fuerza de sujeción de 500 kg
- Bajo consumo de 0.7A para 12 VDC y 0,35A para 24 VDC
- Led indicador de posición de la puerta
- Tratamiento anti-corrosión
- Aplicable en temperaturas desde -60 hasta 80 ° C
- Diseñado para conexión de 12 V o 24 V DC
- Varios accesorios de montaje disponibles.

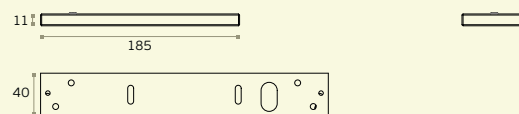
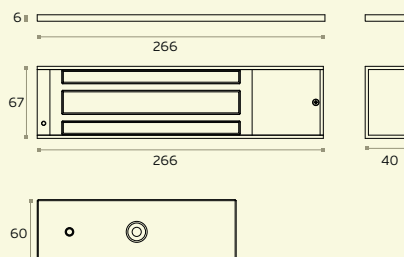



EN 50081-1/1992:EN 55014
EN 500 82-1/1997: EN 55015-2



IN.28.691

FECHADURA ELETROMAGNÉTICA PARA 2 FOLHAS

- Corpo em alumínio anodizado
- Sem magnetismo residual
- Força de retenção de 500 kg por folha.
- Baixo consumo de 0,7A para 12 VDC e 0,35A para 24 VDC
- LED para controle de posição da porta
- Tratamento Anti-corrosão
- Aplicável em temperaturas de -60 a +80 °C
- Projetado para alimentação de 12 V ou 24 V DC
- Disponíveis vários acessórios de fixação.

ELECTROMAGNETIC LOCK FOR 2 LEAF'S

- Body made in anodized aluminum
- No residual magnetism
- Holding force of 500 kg by leaf
- Low consumption 0,7A for 12 VDC and 0,35A for 24 VDC
- Led light for door control
- Anti-corrosion protected
- Suitable for temperatures between -60 and +80°C
- Designed for connection to 12 V or 24 V DC supplies
- available several different fixing accessories

CERRADURA ELECTROMAGNÉTICA PARA 2 HOJAS

- Cuerpo en aluminio anodizado
- Sin magnetismo residual
- Fuerza de sujeción de 500 kg por hoja
- Bajo consumo de 0.7A para 12 VDC y 0,35A para 24 VDC
- Led indicador de posición de la puerta
- Tratamiento anti-corrosión
- Aplicable en temperaturas desde -60 hasta 80 °C
- Diseñado para conexión de 12 V o 24 V DC
- Varios accesorios de montaje disponibles.

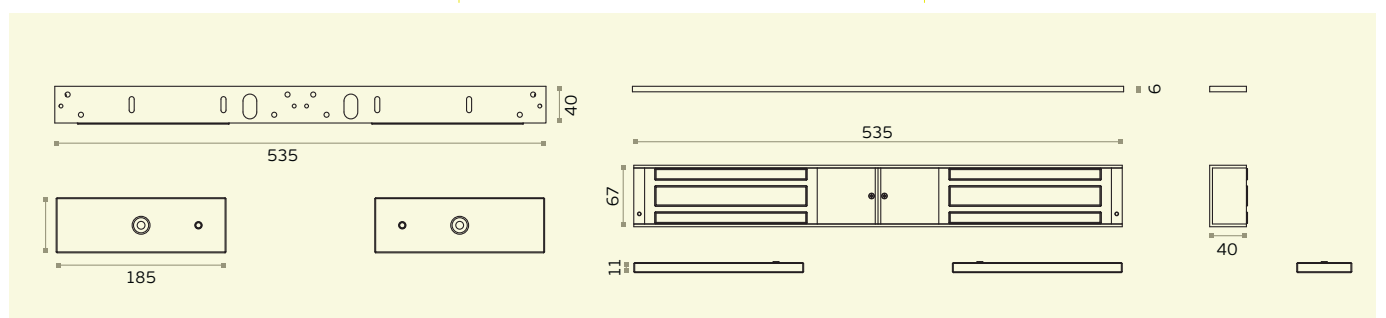

DISPOSITIVOS ELECTROMAGNÉTICOS / ELECTROMAGNETIC DEVICES / DISPOSITIVOS ELECTROMAGNETICOS.

IN.28.693

Suporte em Z ajustável para IN.28.690/691 /
 Adjustable Z bracket for IN.28.690 and IN.28.691 /
 Soporte en Z ajustable para IN.28.690 y IN.28.691/

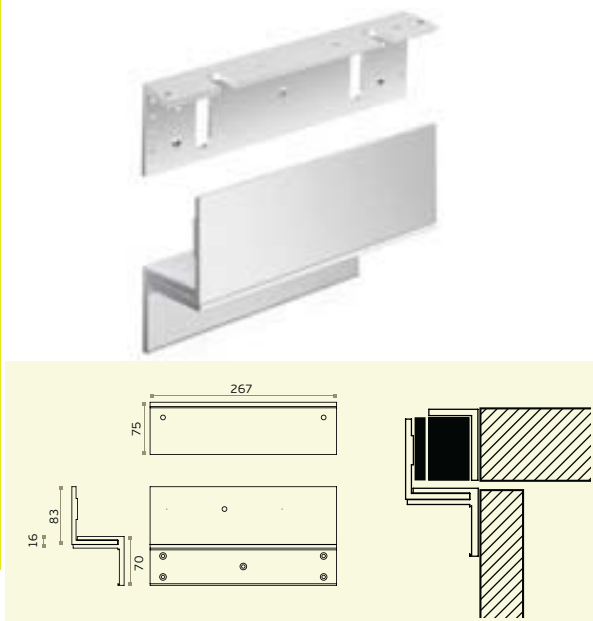

IN.28.694

Suporte em L para IN.28.690 e IN.28.691 /
 L bracket for IN.28.690 and IN.28.691 /
 Soporte en L para IN.28.690 y IN.28.691/

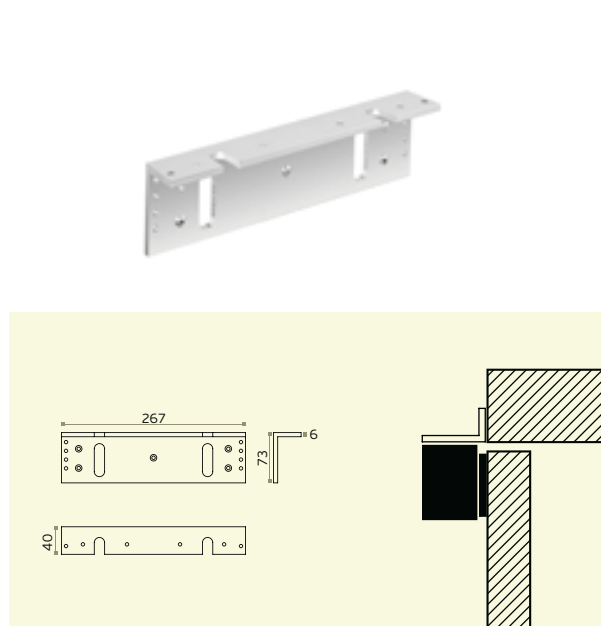

IN.28.695

Armadura para placa aplicável com
IN.28.690 e IN.28.691 /
 Rim armature housing for IN.28.690 and IN.28.691 /
 Armadura para placa aplicavel con
 IN.28.690 y IN.28.691/

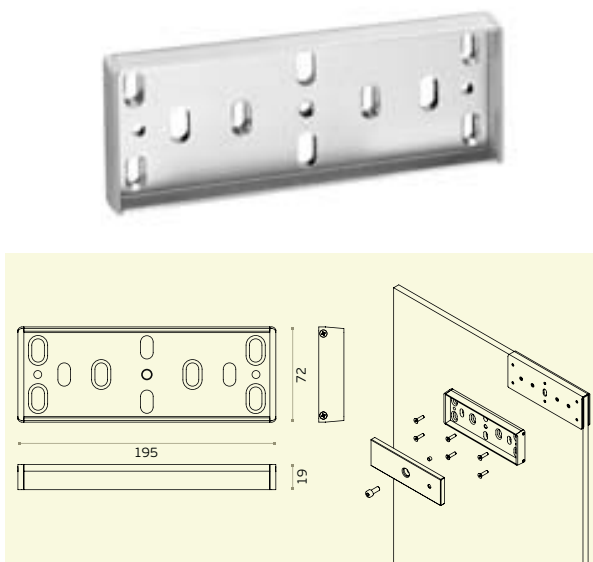

IN.28.696

Pinça para porta em vidro aplicável
com IN.28.695 /
 Glass door clamp for IN.28.695 /
 Pinza para puerta en cristal aplicable con
 IN.28.695/

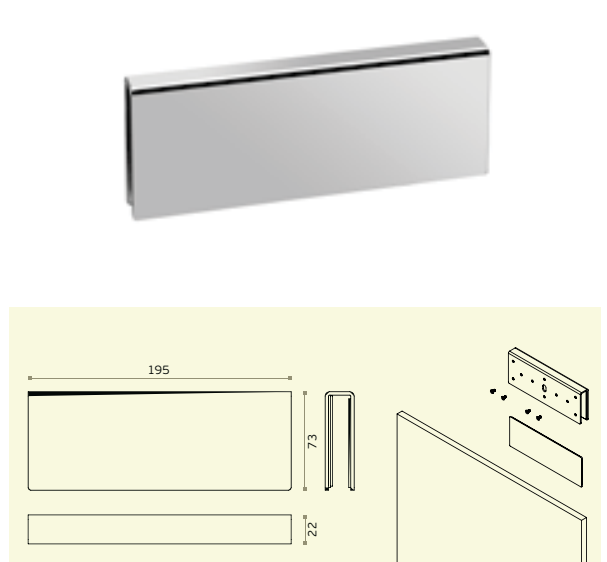



IN.28.685

FECHADURA ELETROMAGNÉTICA DE EMBUTIR

- Corpo em alumínio anodizado
- Sem magnetismo residual
- Força de retenção de 280kg
- Baixo consumo de 0,46A para 12 VDC e 0,23A para 24 VDC
- LED para controle de posição da porta
- Tratamento Anti-corrosão
- Aplicável em temperaturas de -60 a +80 °C
- Projetado para alimentação de 12 V ou 24 V DC
- Disponíveis vários acessórios de fixação.

CONCEALED ELECTROMAGNETIC LOCK

- Body made in anodized aluminum
- No residual magnetism
- Holding force of 280 kg
- Low consumption 0,46A for 12 VDC and 0,23A for 24 VDC
- Led light for door control
- Anti-corrosion protected
- Suitable for temperatures between -60 and +80°C
- Designed for connection to 12 V or 24 V DC supplies
- available several different fixing accessories

CERRADURA ELECTROMAGNÉTICA DE EMBUTIR

- Cuerpo en aluminio anodizado
- Sin magnetismo residual
- Fuerza de sujeción de 280 kg
- Bajo consumo de 0.46A para 12 VDC y 0,23A para 24 VDC
- Led indicador de posición de la puerta
- Tratamiento anti-corrosión
- Aplicable en temperaturas desde -60 hasta 80 ° C
- Diseñado para conexión de 12 V o 24 V DC
- Varios accesorios de montaje disponibles.

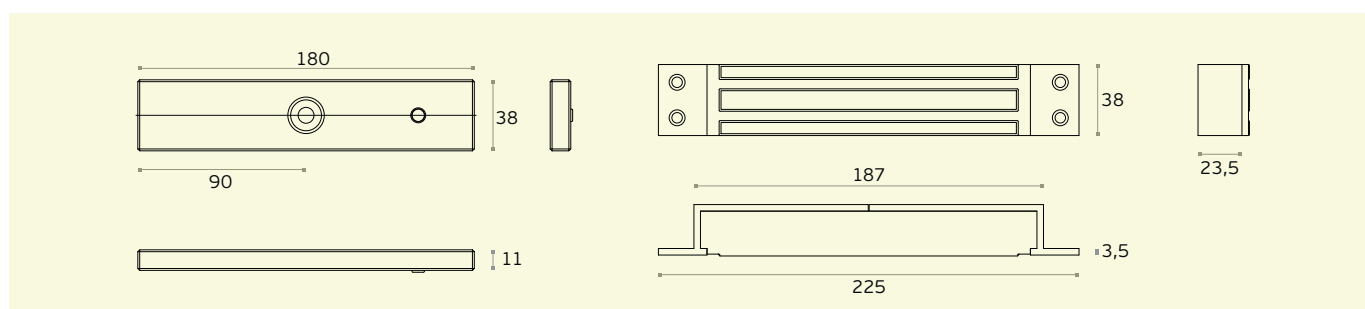

DISPOSITIVOS ELECTROMAGNÉTICOS / ELECTROMAGNETIC DEVICES / DISPOSITIVOS ELECTROMAGNETICOS.



IN.28.680

FECHADURA ELETROMAGNÉTICA

- Corpo em alumínio anodizado
- Sem magnetismo residual
- Força de retenção de 280kg
- Baixo consumo de 0,46A para 12 VDC e 0,23A para 24 VDC
- LED para controle de posição da porta
- Tratamento Anti-corrosão
- Aplicável em temperaturas de -60 a +80 °C
- Projetado para alimentação de 12 V ou 24 V DC
- Disponíveis vários acessórios de fixação.

ELECTROMAGNETIC LOCK

- Body made in anodized aluminum
- No residual magnetism
- Holding force of 280 kg
- Low consumption 0,46A for 12 VDC and 0,23A for 24 VDC
- Led light for door control
- Anti-corrosion protected
- Suitable for temperatures between -60 and +80°C
- Designed for connection to 12 V or 24 V DC supplies
- available several different fixing accessories

CERRADURA ELECTROMAGNÉTICA

- Cuerpo en aluminio anodizado
- Sin magnetismo residual
- Fuerza de sujeción de 280 kg
- Bajo consumo de 0.46A para 12 VDC y 0,23A para 24 VDC
- Led indicador de posición de la puerta
- Tratamiento anti-corrosión
- Aplicable en temperaturas desde -60 hasta 80 ° C
- Diseñado para conexión de 12 V o 24 V DC
- Varios accesorios de montaje disponibles.

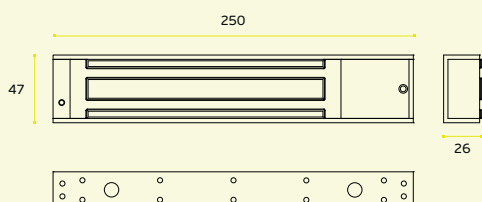

Acessórios para fechaduras electromagnéticas /

Electromagnetic lock accessories / Accesorios para cerraduras electromagnéticas.

IN.28.684

Suporte em Z ajustável para IN.28.680 /
Adjustable Z bracket for IN.28.680 /
Soporte en Z ajustable para IN.28.680 /

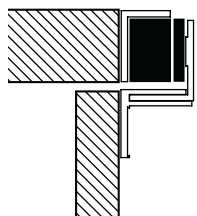
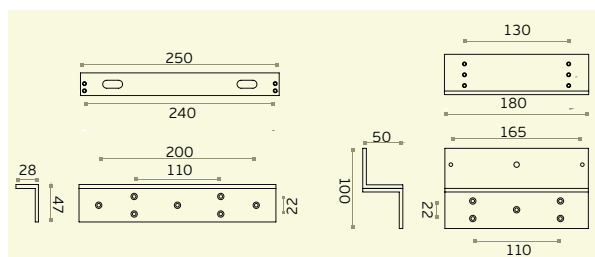

IN.28.683

Pinça para porta em vidro aplicável com IN.28.680 /
Glass door clamp for IN.28.680 / Pinza para puerta en cristal
aplicable con IN.28.680 /

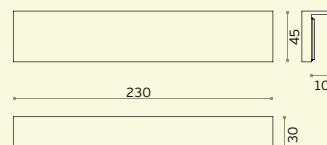

DISPOSITIVOS ELECTROMECAÛNICOS / ELECTRIFIED DOOR HARDWARE / DISPOSITIVOS ELECTROMECAÛNICOS.



12 V

24 V

1200
Kg

IN.28.697

FECHADURA ELETROMAGNÉTICA COM BLOQUEIO MECÂNICO

- Corpo em alumínio anodizado
- Sem magnetismo residual
- Força de retenção de 1200kg
- Baixo consumo de 1,15A para 12 VDC e 1,55A para 24 VDC
- Para portas estreitas min 35mm
- Tratamento Anti-corrosão
- Aplicável em temperaturas de -60 a +80 °C
- Projetado para alimentação de 12 V DC ou 24 V DC (1,10 A a 2 A)
- Disponíveis vários acessórios de fixação.

SHEAR LOCK

- Body made in anodized aluminum
- No residual magnetism
- Holding force of 1200 kg
- Low consumption 1,15A for 12 VDC and 1,55A for 24 VDC
- For low thickness doors min 35mm
- Anti-corrosion protected
- Suitable for temperatures between -60 and +80°C
- Designed for connection to 12 V DC or 24 V DC (1,10 A a 2 A) supplies
- available several different fixing accessories

CERRADURA ELECTROMAGNÉTICA CON BLOQUEO MECANICO

- Cuerpo en aluminio anodizado
- Sin magnetismo residual
- Fuerza de sujeción de 1200 kg
- Bajo consumo de 1.15A para 12 VDC y 1,55A para 24 VDC
- Para puertas estrechas min 35mm.
- Tratamiento anti-corrosión
- Aplicable en temperaturas desde -60 hasta 80 ° C
- Diseñado para conexión de 12 V DC o 24 V DC (1,10 A a 2 A)
- Varios accesorios de montaje disponibles.

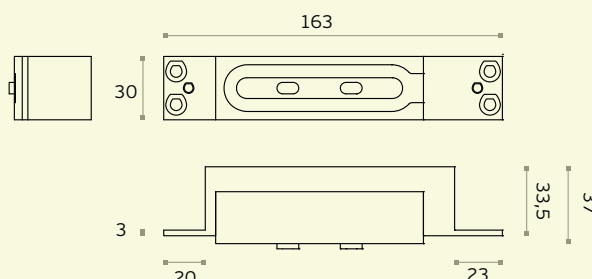
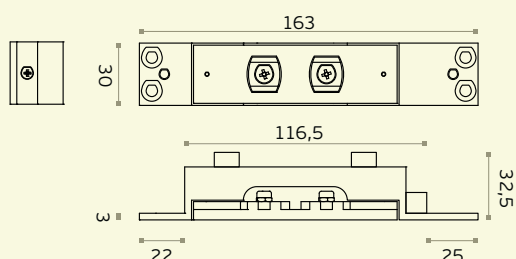



Acessórios para dispositivos electromecânicos /

Electrified door hardware Accessories / Accesorios para Dispositivos electromecânicos.

IN.28.698

Caixa em alumínio para sobrepor aplicável com IN.28.697 /
Aluminium surface mounting housing for IN.28.697 /
Caja en aluminio de sobreponer aplicable con IN.28.697

Espessura de vidro /
Glass thickness / Espesor del cristal **10 - 12,7 mm**

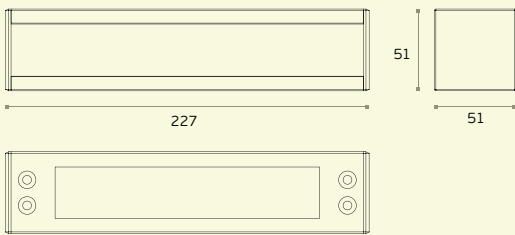

IN.28.699

Pinça para porta em vidro aplicável com IN.28.697 /
Glass door clamp for IN.28.697 /
Pinza para puerta en cristal aplicable con IN.28.697

Espessura de vidro /
Glass thickness / Espesor del cristal **10 - 12,7 mm**

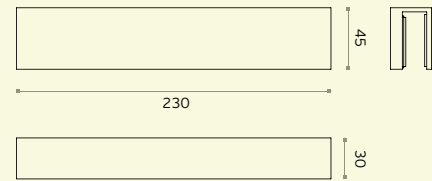

IN.28.698.1

Placa de enchimento de 1mm /
1mm filler plate /
Placa de relleno de 1mm. /

IN.28.698.2

Placa de enchimento de 2mm /
2mm filler plate /
Placa de relleno de 2mm. /

IN.28.698.6

Placa de enchimento de 6mm /
6mm filler plate /
Placa de relleno de 6mm. /

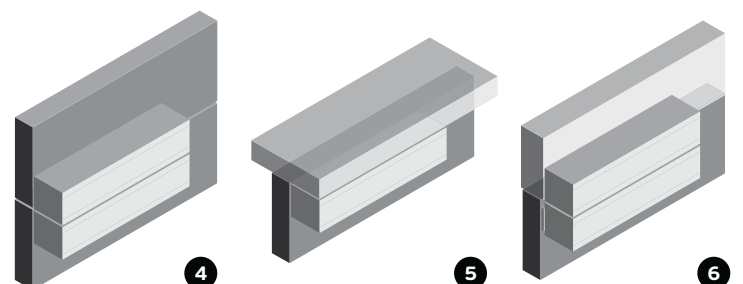
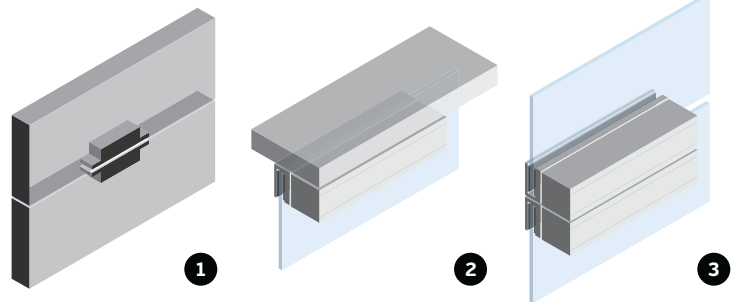
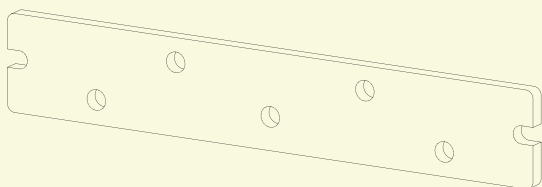

DISPOSITIVOS ELECTROMECHANICOS / ELECTRIFIED DOOR HARDWARE / DISPOSITIVOS ELECTROMECHANICOS.

As fechaduras eléctricas "DROP PIN" JNF são adequadas para portas interiores, portas de saída ou de entrada, que requerem libertação de emergência e sistemas de controle de acesso.

Instalação oculta.

Podem ser instaladas horizontalmente na parte superior ou verticalmente no lado da porta ou aro.

Potencia de entrada: 12 V DC
Testado 500000 ciclos

JNF electric drop pin locks are suitable for interior doors, exit or entrance doors, that require fail safe emergency release capability and access control systems.

Fully concealed mounting.

Can be either installed horizontally on top or vertically on the side of the door or door frame

Power Input: 12 V DC
Tested to 500000 cycles.

Las cerraduras eléctricas "drop pin" JNF son adecuadas para puertas interiores, puertas de salida o de entrada, que requieren liberación de emergencia y sistemas de control de acceso

Instalación oculta.

Pueden ser instaladas horizontalmente en la parte superior o verticalmente en el lado de la puerta o del marco.

Potencia de entrada: 12 V DC
Testado 500000 ciclos

Desenhadas para portas de acção dupla ou simples.

Circuito electrónico desenhado de forma a manter o trinco recolhido enquanto a porta não está fechada. Este sistema de segurança previne qualquer possibilidade de erros ao fechar a porta, mesmo que acidentalmente seja dada a indicação de fecho.

Ajuste de tempo de 0 a 9 segundos de atraso no fecho do trinco. Este é o tempo que o "PIN" demora a recolher ou subir após o fecho da porta.

Designed for double or single action doors.

Intelligent circuit design keeps the bolt retracted while the door is not locked on strike plate absolutely until the door closed properly. This design is for security purpose, which prevents the chance of negative locking problem caused by the improper door positioning.

Adjusted time between 0 to 9 seconds for door locking time delay. This is the time, which takes the drop pin to automatically lock after door is closed.

Diseñadas para puertas de acción simple o doble.

Circuito electrónico diseñado para mantener el pestillo retraído mientras que la puerta no está cerrada. Este sistema de seguridad impide cualquier posibilidad de errores al cerrar la puerta, aunque, accidentalmente se da una indicación de cierre.

Ajuste de tiempo de 0 a 9 segundos de retraso en el cierre del pestillo. Este es el tiempo de que el "PIN" tarda en subir o bajar después de cerrar la puerta.



DISPOSITIVOS ELECTROMECÂNICOS / ELECTRIFIED DOOR HARDWARE / DISPOSITIVOS ELECTROMECHANICOS.

IN.28.501

Fechaduras eléctrica "DROP PIN" para cilindro europeu
Função sempre fechado, pode ser aberto
atraves do cilindro.

Electric drop pin lock for european cylinder
 Always lock function. Can be open trough the cylinder /
 Cerradura electrica " DROP PIN" para cilindro europeu Funcion
 siempre cerrado. Puede ser abierto con el cilindro.

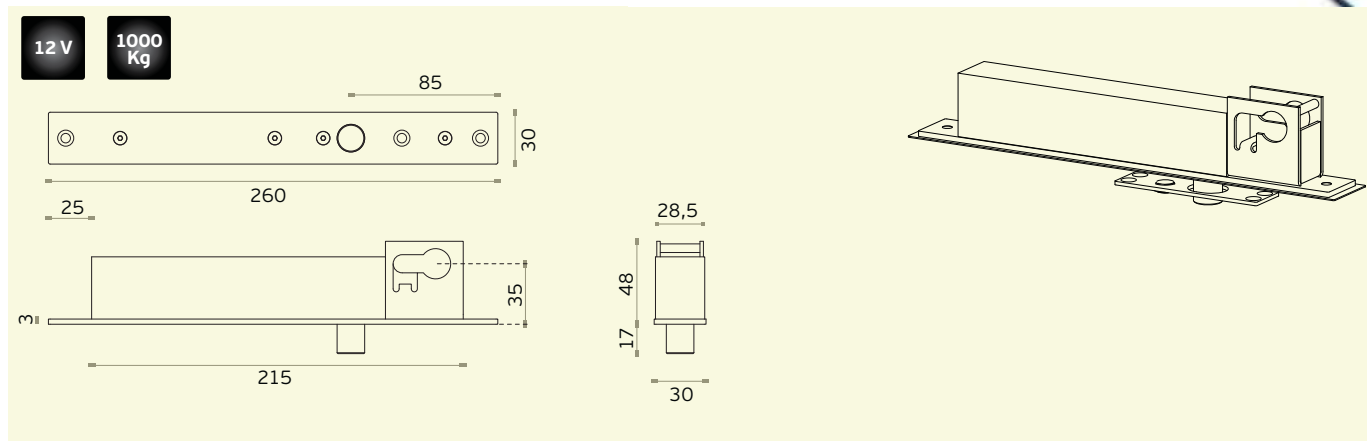

IN.28.502

Fechaduras eléctrica "DROP PIN"
Função sempre fechado

Electric drop pin lock
 Always lock function
 Cerradura electrica " DROP PIN"
 Funcion siempre cerrado

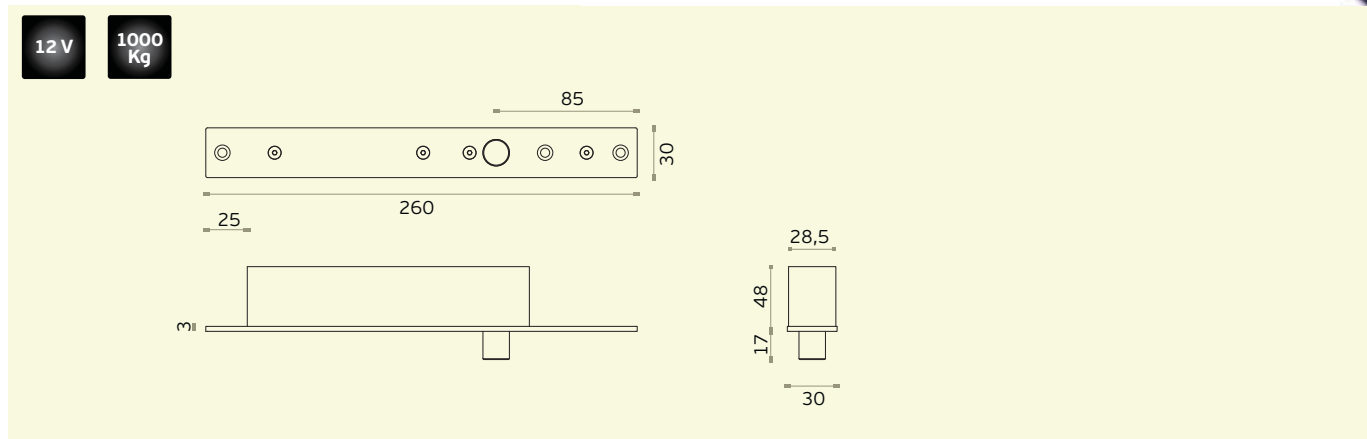

IN.28.503

Fechaduras eléctrica "DROP PIN" para cilindro europeu
Função aberto, só fecha com corrente eléctrica.

A porta fica aberta com falha de corrente

Electric drop pin lock for european cylinder
Open function, only lock with electric power.

The door stays open when there is no power

Cerradura electrica " DROP PIN" para cilindro europeu

Funcion abierto, solo cierra con energia electrica

La puerta se queda abierta con corte de energia



12 V

1000
Kg

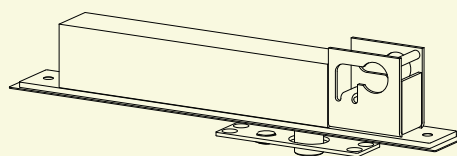
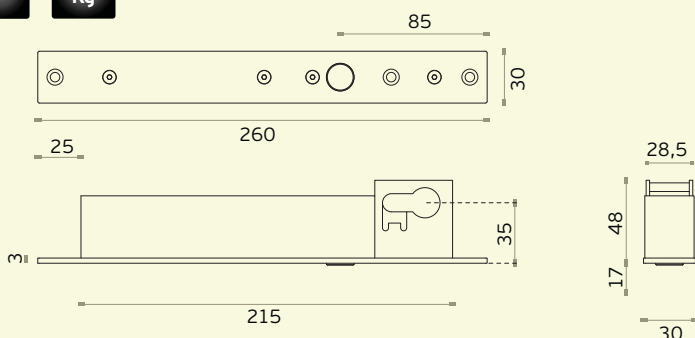

IN.28.504

Fechaduras eléctrica "DROP PIN"

Função aberto, só fecha com corrente eléctrica.

A porta fica aberta com falha de corrente

Electric drop pin lock

Open function, only lock with electric power.

The door stays open when there is no power

Cerradura electrica " DROP PIN"

Funcion abierto, solo cierra con energia electrica

La puerta se queda abierta con corte de energia



12 V

1000
Kg

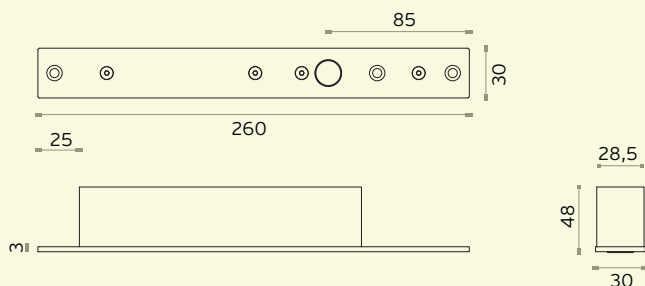

DISPOSITIVOS ELECTROMECÂNICOS / ELECTRIFIED DOOR HARDWARE / DISPOSITIVOS ELECTROMECHANICOS.



12 V

1000
Kg

IN.28.505

Fechaduras eléctrica "DROP PIN".
Função aberto, só fecha com corrente eléctrica.
A porta fica aberta com falha de corrente.

Entrada: 12 V DC
Consumo: 0,9 A
Ajuste de tempo de fecho: 0, 3, 6, 9 seg.
Tampa em aço inoxidável

Electric drop pin lock.
 Open function, only lock with electric power.
 The door stays open when there is no power

Voltage: 12V DC
Current: 0.9 A
Time delay: 0, 3, 6, 9 sec
Stainless steel cover.

Cerradura electrica " DROP PIN"
Funcion abierto, solo cierra con energia electrica.
La puerta se queda abierta con corte de energia

Corriente de entrada 12 V DC
Consumo: 0,9 A
Ajuste en el tiempo de cierre: 0, 3, 6, 9 seg
Cubierta en acero inoxidable

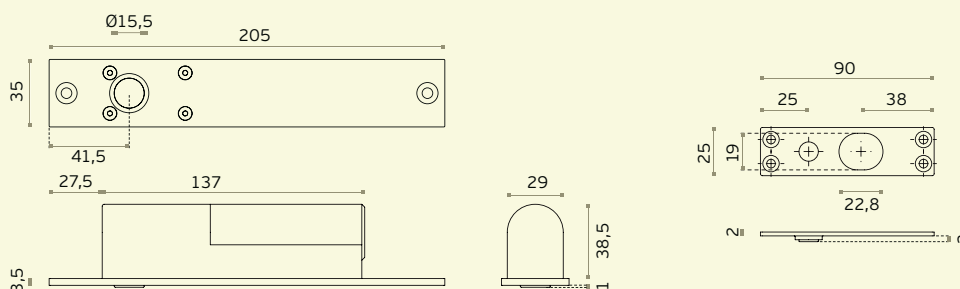

IN.28.511

Caixa testa para porta em vidro aplicável com IN.28.510. Em aço inoxidável /
Strike box for glass door for IN.28.510. Made in stainless steel /
Caja cerradero para puerta en cristal aplicable con IN.28.510. En acero inoxidable. /

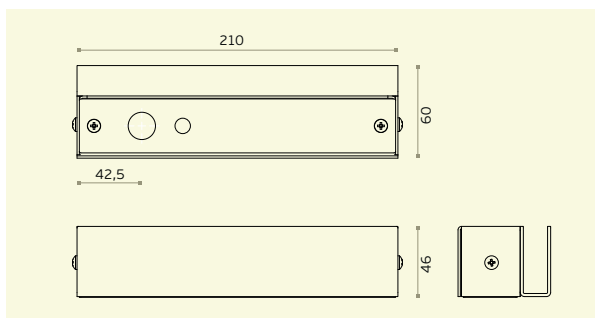

IN.28.510

Caixa para aplicar IN.28.505 em porta de vidro Em aço inoxidável /
Box to install IN.28.505 in glass door. Made in stainless steel /
Caja para aplicar IN.28.505 en puerta de cristal. En acero inoxidable. /

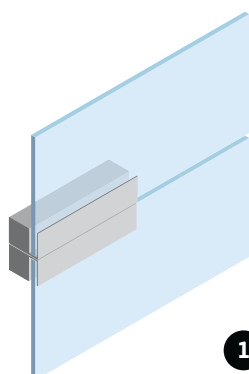
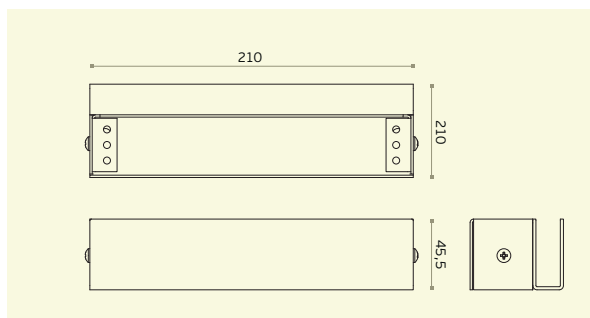
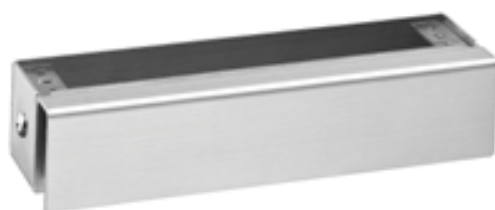

1

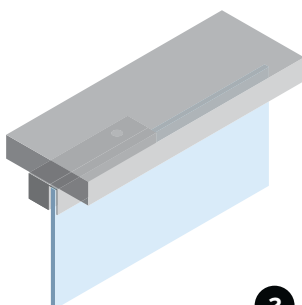

2



DISPOSITIVOS ELECTROMAGNÉTICOS / ELECTROMAGNETIC DEVICES / DISPOSITIVOS ELECTROMAGNETICOS.

IN.28.701

Retentor electromagnético.

Fixação de parede ou pavimento.

Entrada: 12 e 24 V DC

Consumo: 0,98 A com 12 V DC , 0,49A com 24 V DC

Botão para desbloqueio manual.

Força de retenção: 65 KG

Saídas de sinal: N.C. e N.O.

Aplicável em temperaturas de -20 a +70 °C

Armadura com inclinação máxima de 5°.

Electromagnetic door holder.

Can be installed on the wall or floor.

Power Input: 12V DC and 24V DC

Consumption: 0.98 A with 12 V DC, 0.49A with 24 V DC

Manual unlocking button.

Holding force: 65 KG

Outputs signal: N.C. and N.O.

Applicable in temperatures from -20 to +70 °C

Armature allows maximum 5°.

Retenedor electromagnético.

Aplicable en la pared o el piso.

Entrada: DC 12V y 24V

Consumo: 0,98 A con 12 V DC, 24 V DC con 0,49A

Botón de desbloqueo manual.

Fuerza de retención: 65 KG

Señal de Salida: N.C. y N.O.

Aplicable en temperaturas de -20 a +70 °C

Base con inclinación máxima de 5°.



12 V

24 V



65 Kg

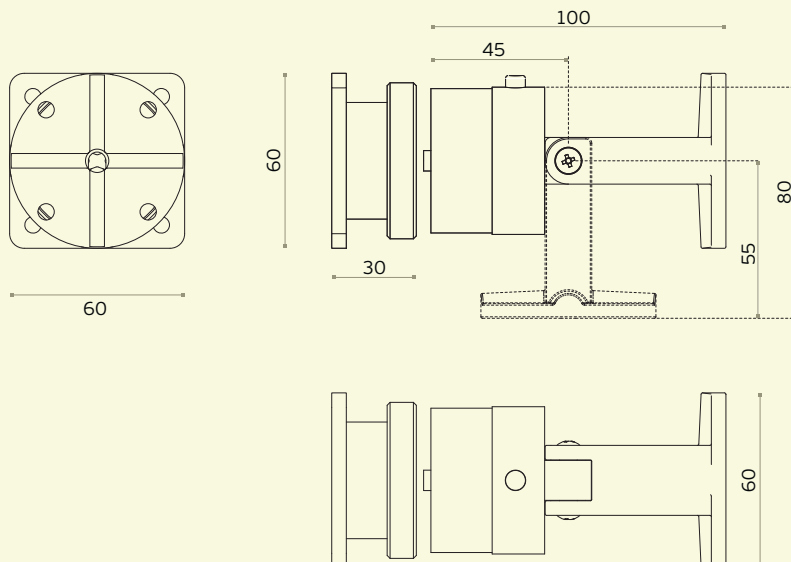





Acessórios para dispositivos electromagnéticos e electromecânicos / Electromagnetic and electromechanical accessories / Accesorios para dispositivos electromagneticos y electromecanicos.

IN.28.110

Fonte de alimentação.
Corrente de entrada 110 /
230 VAC.
Corrente de saída 12VDC.
- Ligação NC/NO.
- Temporizador de abertura
2 saídas de corrente
-1x saída de 1A - constante
-1x saída de 1,5A - controlada
por activação e temporizada.

Power supply.
Input 110/230 VAC.
Output 12VDC.
Conection NC/NO.
Oppening timer.
2 Outputs
-1x constant 1A output
-1x timed and controlled by
activation 1,5A

Fuente de alimentación.
Entrada 110/230VAC.
Salida 12VDC.
Conexión NC/NO.
Temporizador de apertura.
2 salidas de corriente
-1x salida de 1A - constante
-1x salida de 1,5A - controlada
por activación y temporizada

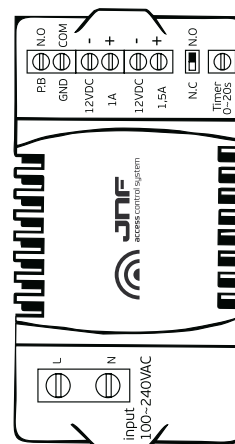

IN.28.112

Fonte de alimentação.
Corrente de entrada
110 / 230 VAC.
Corrente de saída 12VDC.

Power supply.
Input 110/230 VAC.
Output 12VDC.

Fuente de alimentación.
Entrada 110/230VAC.
Salida 12VDC.



IN.28.111

Fonte de alimentação com sistema UPS de emergência. Permite corrente contínua com duração de 24 horas
Corrente de entrada 110 / 230 VAC.
Corrente de saída 12VDC.
- Ligação NC/NO.
- Temporizador de abertura

Power supply with emergency UPS system. Allow constant power during 24 hours
Input 110/230 VAC.
Output 12VDC.
Connection NC/NO.
Opening timer.

Fuente de alimentación con sistema de UPS de emergencia, permite corriente continua durante 24 horas.
Entrada 110/230VAC.
Salida 12VDC.
Conexión NC/NO.
Temporizador de apertura.



BARRAS ANTI-PÂNICO / PANIC EXIT DEVICES / DISPOSITIVOS ANTIPÁNICO.

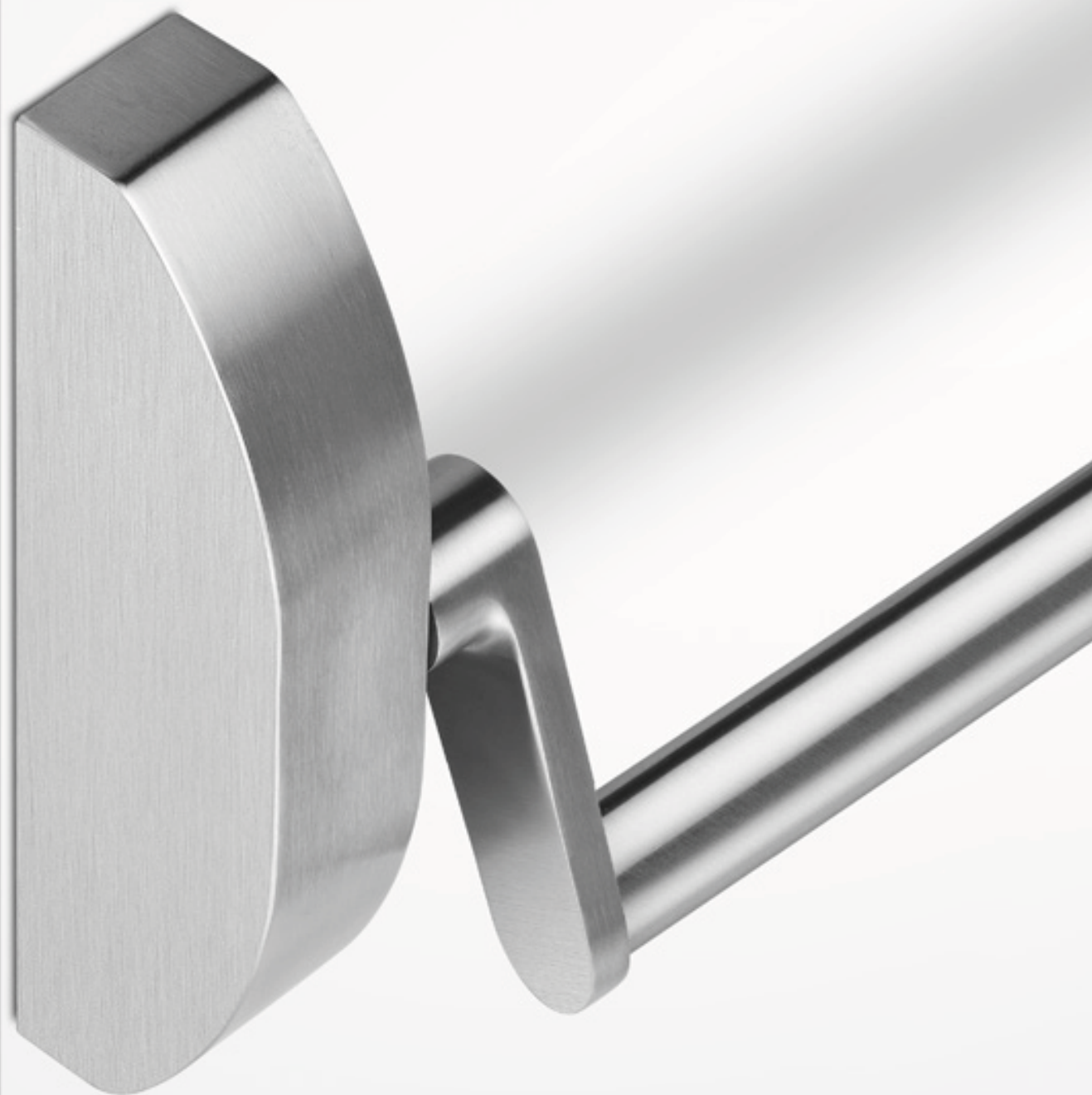

A série de barras anti-pânico JNF permite solucionar quase todas as situações, desde portas simples, duplas, de vidro, madeira, metálicas, etc..

Todas as barras são certificadas de acordo com as normas EN 1125 e possuem marcação CE, padrões que são obrigatórios para todos os dispositivos anti-pânico e/ou de emergência.

As barras são reversíveis, sendo efectuada a troca de uma forma muito rápida e intuitiva.

As tampas, barras e tubos são fabricados em aço inoxidável EN 1.4301 com acabamento escovado. Mecanismos internos são em aço galvanizado.

Possibilidade de cortar a barra horizontal. Possibilidade de ajustar 40mm as barras verticais, assim como cortar se necessário. Caixas estreitas com 39mm que permitem aplicar em qualquer perfil de alumínio.

The JNF Panic exit devices series allows to solve almost all situations, from simple door, double, glass, wood, metal, etc...

All the bars are certified according to EN 1125 standards and have CE marking, standards that are mandatory for all the anti-panic and / or emergency devices.

The bars are reversible, and the exchange is very quick and intuitive. Covers, bar and tube are made of stainless steel EN 1.4301 with brushed finish.

Internal mechanisms are made of galvanized steel. Be cut horizontal bar The vertical bars can be adjusted 40mm, and cutted if necessary Narrow boxes with 39mm fit in any aluminum profile.

La serie de cerraduras antipánico permite solucionar casi todas las situaciones, de puerta simple, doble, vidrio, madera, metal, etc ...

Todos los dispositivos están certificados según las normas EN 1125 y han marcado CE, normas que son obligatorias para todos los anti-pánico y / o dispositivos de emergencia.

Las barras son reversibles, y el cambio es muy rápido e intuitivo. Tapas, brazos y tubos hechas de acero inoxidable EN 1.4301 con acabado satin. Los mecanismos internos son de acero galvanizado.

Puede cortar de barra horizontal Las barras verticales se pueden ajustar 40 mm, o cortar se es necesario Cajas estrechas con 39mm caben en cualquier perfil de aluminio.

DECLARAÇÃO DE DESEMPENHO / MARCAÇÃO CE

DECLARATION OF PERFORMANCE (DOP) / CE MARKING/

DECLARACIÓN DE PRESTACIONES / MARCADO CE

Declaração de Desempenho / Marcação CE

O Regulamento (UE) n.º 305/2011 entrou em vigor em 1 de Julho de 2013, o qual estabelece condições harmonizadas para a comercialização dos produtos de construção e revoga a Directiva 89/106/CEE.

O presente regulamento obriga os fabricantes de produtos de construção a elaborar uma declaração de desempenho quando um produto de construção abrangido por uma norma harmonizada ou conforme com uma Avaliação Técnica Europeia emitida para esse produto.

Ao fazer a declaração de desempenho, o fabricante assume a responsabilidade legal pela conformidade do produto de construção com o desempenho declarado. Se a declaração de desempenho não tiver sido efetuada pelo fabricante, a marcação CE não pode ser aposta.

As barras anti-pânico só podem apresentar a marcação CE quando as mesmas têm utilização prevista em portas em caminhos de evacuação. Neste caso deve-se seguir o Sistema 1 de avaliação e verificação da regularidade do desempenho.

Norma harmonizada para fechaduras: EN1125 – Dispositivos de fecho anti-pânico para saídas de emergência accionados por uma barra horizontal

Declaration of Performance (DoP) / CE Marking

The Regulation (EU) No 305/2011 entered in to force on July 1, 2013, laying down harmonised conditions for the marketing of construction products and repealing Council Directive 89/106/EEC.

This regulation requires manufacturers of construction products to draw up a declaration of performance when a construction product covered by a harmonised standard, or complies with an European Technical Assessment issued for this product.

Making a declaration of performance, the manufacturer assumes legal responsibility for the conformity of the product with the declared performance. If the performance statement hasn't been made by the manufacturer, CE marking cannot be affixed.

The antipanic lock must have the CE marking when they have an intended use for doors on escape route. In this case should follow the System 1 of assessment and verification of constancy of performance.

Harmonised Standard for locks: EN1125 – Panic exit devices operated by a horizontal bar

Declaración de Prestaciones / Marcado CE

El Reglamento (UE) nº 305/2011 entró en vigor en 1 Julio 2013, que establece condiciones armonizadas para la comercialización de los productos de construcción y se deroga la Directiva 89/106 / CEE.

Esta regulación exige a los fabricantes de productos de construcción a elaborar una declaración de prestaciones cuando un producto de construcción cubierto por una norma armonizada, o cumple con una evaluación técnica europea emitida para este producto.

Hacer una declaración de prestaciones, el fabricante asume la responsabilidad legal de la conformidad del producto con las prestaciones declaradas. Si la declaración de prestaciones no hay sido hecha por el fabricante, el marcado CE no puede ser fijado.

La cerradura antipánico debe tener el marcado CE cuando tienen un uso previsto para puertas en ruta de escape. En este caso, debe seguir el Sistema 1 de evaluación y verificación de la constancia de las prestaciones.

Norma armonizada para cerraduras : EN1125 - Dispositivos antipánico para salidas de emergencia accionadas por una barra horizontal.

ICONOGRAFIA - CARACTERÍSTICAS TÉCNICAS / ICONOGRAPHY - TECHNICAL DATA / ICONOGRAFÍA - CARACTERÍSTICAS TÉCNICAS



Fechadura para porta anti-pânico /
Lock for antipanic door /
Cerradura para puerta antipánico.



Marcação CE /
CE Marking /
Marcado CE.



Certificadas segundo a Norma Europeia /
Certified Accordingly to the European Norm /
Certificadas segundo la Norma Europea.



Barra horizontal /
Horizontal panic device /
Barra horizontal.



Aplicável com fechadura de embutir /
Applicable with mortice lock /
Aplicable con cerradura de embutir.



Barra horizontal com fecho vertical /
Horizontal panic device with upper and lower latch /
Barra horizontal con cierra vertical.



Barra Anti-Pânico reversível /
Antipanic Reversible Lock /
Cerradura Antipánico reversible.



Utilização para sistemas Corta Fogo /
Use for fire proof systems /
Uso para sistemas corta fuego.



Número de chaves por cilindro /
Number of keys by cylinder /
Numero de llaves.



Permite planos de mestragem /
Allows plans of master key system /
Capacidad de crear planos de amaestramiento.



Trinco lateral /
Lateral latch /
Picaporte lateral.



Puxador rotativo no exterior /
Lever handle from outside
Manilla por el exterior.



Sem funcionamento pelo exterior /
Without Access from outside /
Sin funcionamiento por el exterior.



Puxador Fixo no exterior /
Fixed Knob from outside
Pomo Fijo por el exterior.



Por chave pelo exterior /
With key from outside /
Por llave por el exterior.

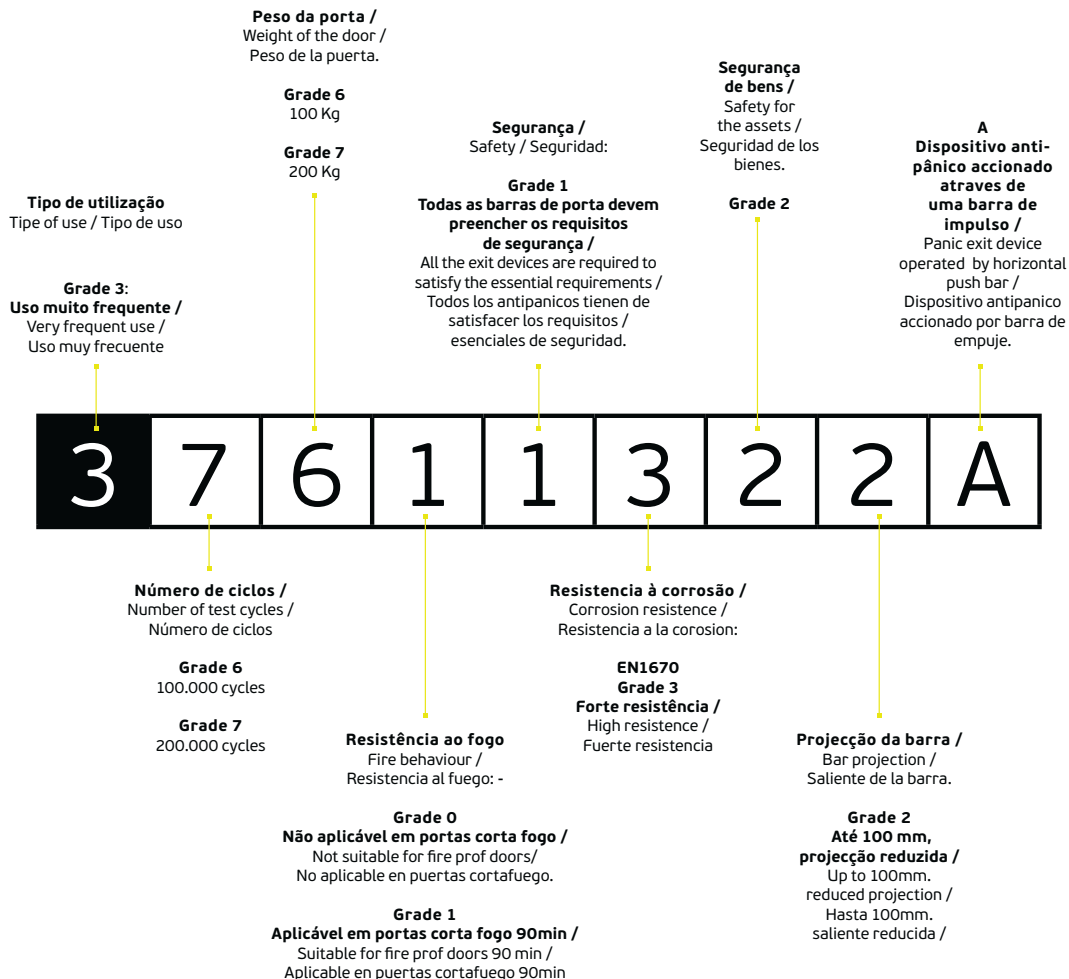

BARRAS ANTI-PÂNICO DE SOBREPOR / RIM PANIC EXIT DEVICES / DISPOSITIVOS ANTIPÁNICO DE SOBREPONER.

Caixa interior fechada e reforçada /
Closed and reinforced inner body /
Caja interior cerrada y reforzada

Sistema reversível para puxador e cilindro /
Reversible system for lever handle and cylinder /
Sistema reversible para manilla y cilindro

Modelo de puxador pode ser trocado /
Lever handle model can be changed /
Modelo de manilla puede ser cambiado.

Proteção de cilindro sólida /
Solid cylinder protection /
Protección de cilindro robusta.

Acessórios disponíveis para aplicação em portas de vidro /
Available accessories to install in glass doors /
Acessorios disponibles para instalar en puertas de cristal

Tampa aço inoxidável EN 1.4301 /
Stainless steel EN 1.4301 cover /
Cubierta en acero inoxidable EN 1.4301.

Meio cilindro europeu de segurança
Pode ser aplicado qualquer modelo de cilindro europeu 10x30mm.
Permite planos de mestragem ou grupos de chaves iguais /
Security half European cylinder.
Can be installed any model of European cylinder 10x30mm.
Allows master key plans or keys alike groups /
Medio cilindro Europeo de Seguridad
Se puede aplicar cualquier modelo de cilindro Europeo 10x30mm.
Permite planos amostramento o grupos de llaves igualadas /



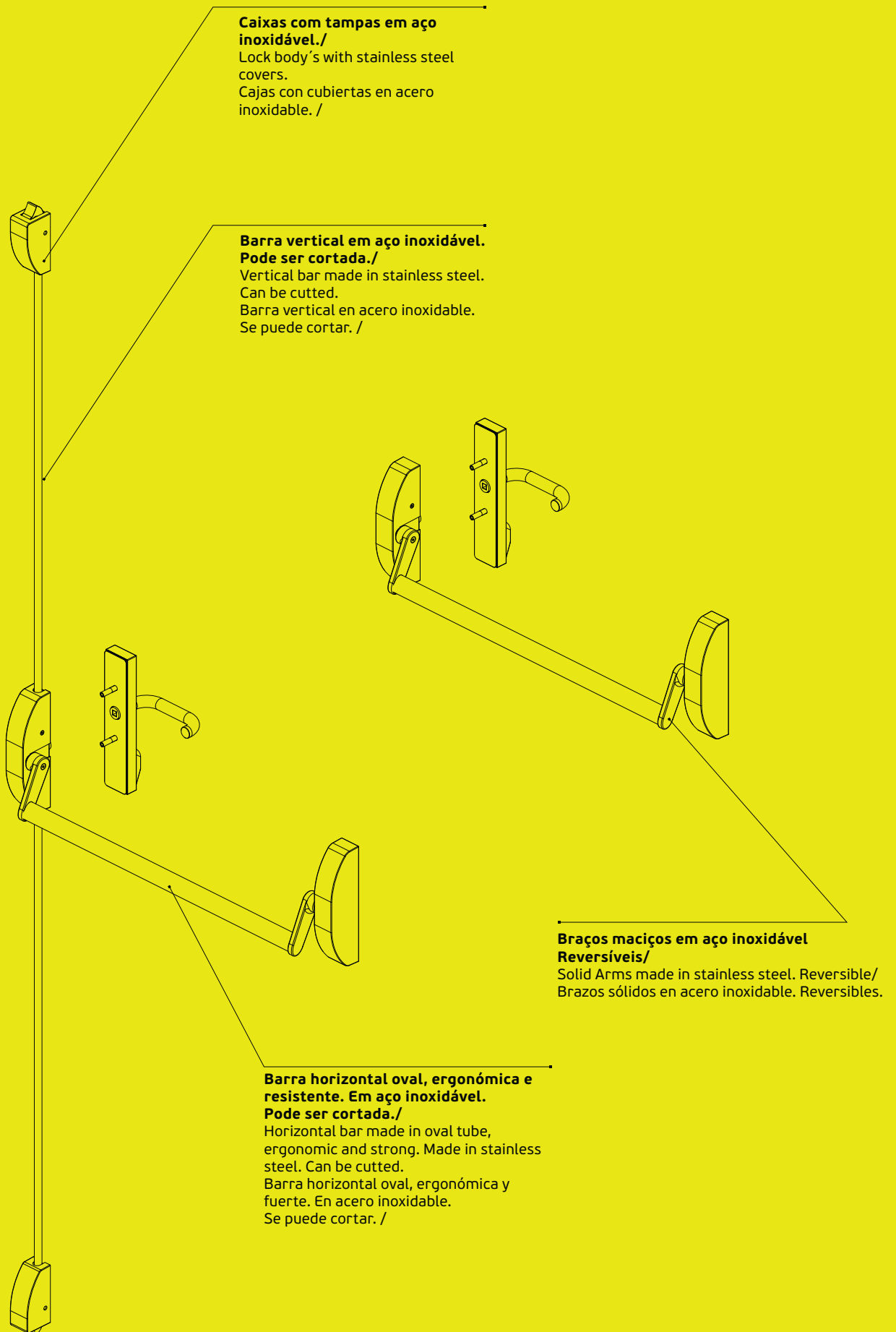

BARRAS ANTI-PÂNICO DE SOBREPOR / RIM PANIC EXIT DEVICES / DISPOSITIVOS ANTIPÁNICO DE SOBREPONER.

IN.20.951

Barra anti-pânico reversível para porta de 1 folha. Fecho através de trinco lateral. Sem funcionamento através do exterior /

Antipanic reversible lock for single doors. Closing system through a side latch. Without access from external side /

Cerradura antipánico reversible para puertas de 1 hoja. Cierre por picaporte basculante lateral. Sin funcionamiento por el exterior /

Material: EN 1.4301
Satinado / Satin / Satin

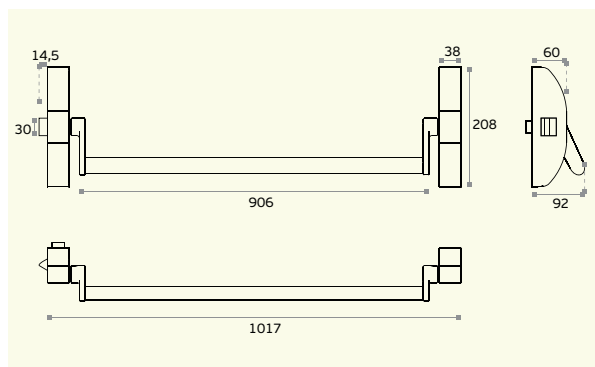

EN 1.4301
IN.20.951

RAL 9006
FA.20.951

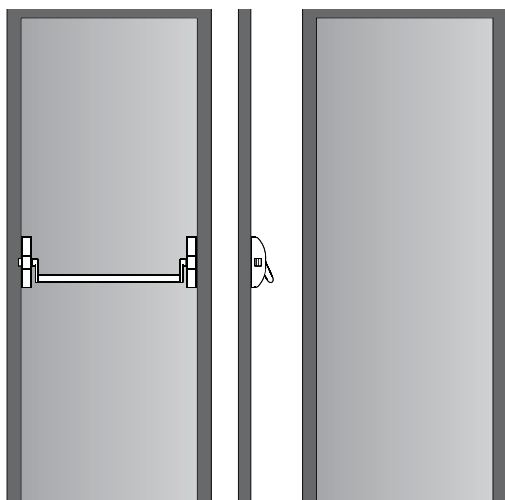

3 7 6 B 1 3 2 2 A A

3 7 5 - 1 3 2 2 A B

IN.20.952

Barra anti-pânico reversível para porta de 1 Folha. Fecho através de trinco lateral. Abertura por chave através do exterior. Puxador rotativo com placa e cilindro incluídos /

Antipanic reversible lock for single doors. Closing system through a side latch. Opening by key from the outside. Lever handle with plate and cylinder included /

Cerradura antipánico reversible para puertas de 1 Hoja. Cierre por picaporte basculante lateral. Apertura por llave por el exterior. Manilla, placa y cilindro incluidos.

Material: EN 1.4301
Satinado / Satin / Satin

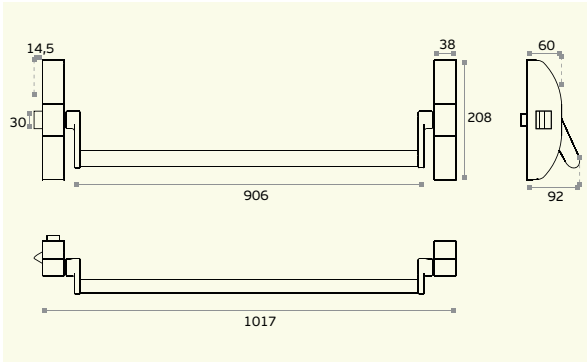

EN 1.4301
IN.20.952

RAL 9006
FA.20.952

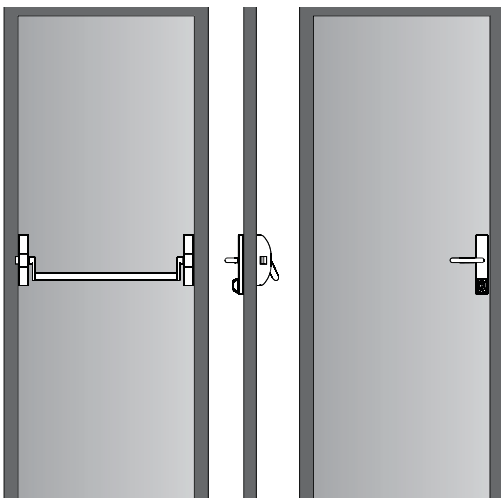

BARRAS ANTI-PÂNICO DE SOBREPOR / RIM PANIC EXIT DEVICES / DISPOSITIVOS ANTIPÁNICO DE SOBREPONER.

IN.20.953

Barra Anti-Pânico para portas de 2 folhas.
Instalação na folha passiva. Fecho através de Trinco Superior e Inferior. Pode ser instalada conjuntamente com as barras Ref: IN.20.951/952.
Funcionamentos possíveis através do exterior são determinados pela fechadura da folha activa. /

Antipanic lock for double doors. Installation at the secondary door. Closing system through upper and lower Latch. This lock can be installed with the lock Ref: IN.20.951/ 952. The possible operations from the outside will be determined by the main door lock. /

Cerradura Antipánico para puertas de 2 hojas. Cierre por Picaporte superior y inferior. Cerradura para la puerta pasiva. Esta cerradura se puede instalar con la cerradura Ref: IN.20.951/ 952. El funcionamiento exterior es determinado por la cerradura de la puerta activa.

Material: EN 1.4301
Satinado / Satin / Satin

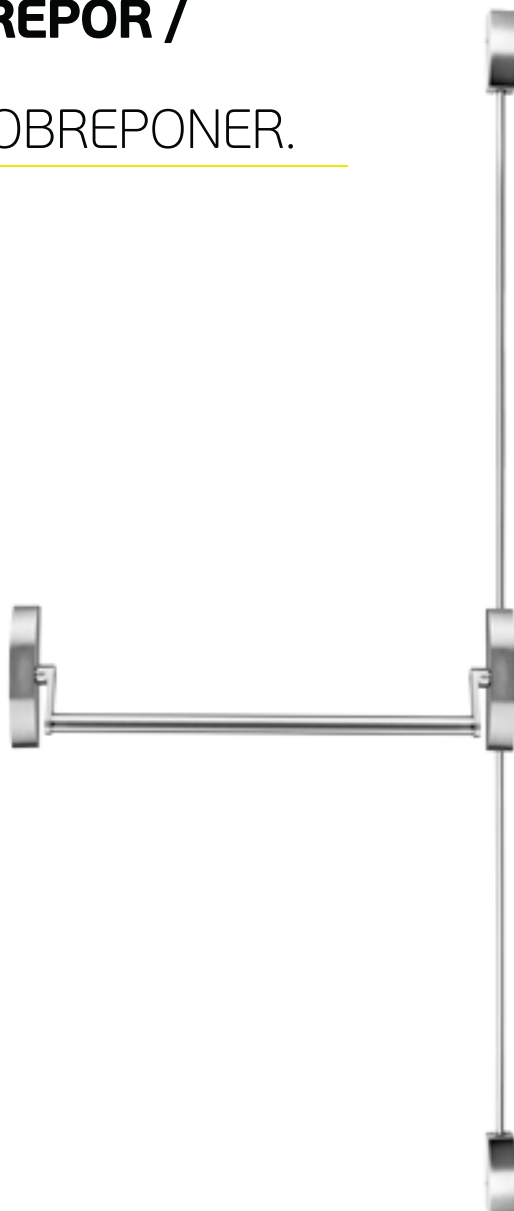
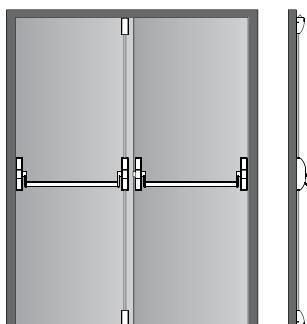
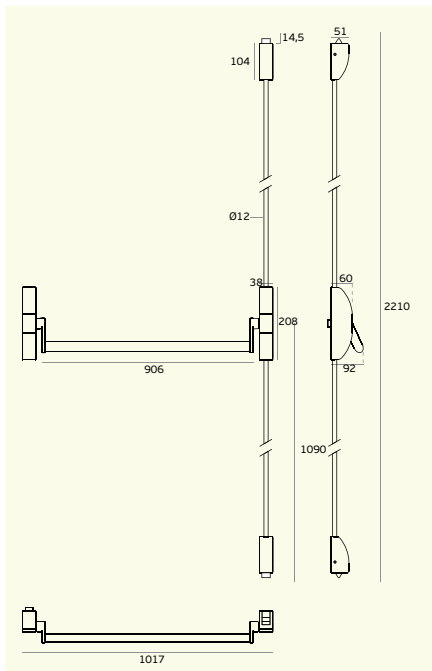

EN 1.4301
IN.20.953

RAL 9006
FA.20.953



3 7 6 B 1 3 2 2 A A

3 7 5 - 1 3 2 2 A B

IN.20.954

Barra Anti-Pânico Reversível.
Fecho através de Trinco Superior e Inferior.
Abertura por chave ou puxador através
do exterior. Puxador com placa e cilindro
incluídos /

Antipanic Reversible Lock. Closing System trough
upper and lower Latch. Opening by key and lever
handle from the outside. Lever handle with plate
and cylinder included /

Cerradura Antipánico Reversible. Cierre por
Picaporte superior y inferior. Apertura por llave
y manilla por el exterior. Manilla, placa y cilindro
inclusos.

Material: EN 1.4301
Satinado / Satin / Satin

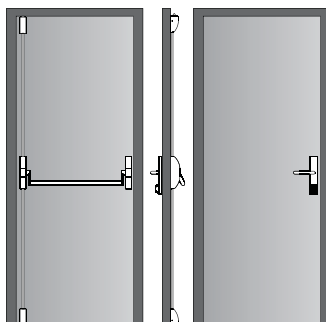
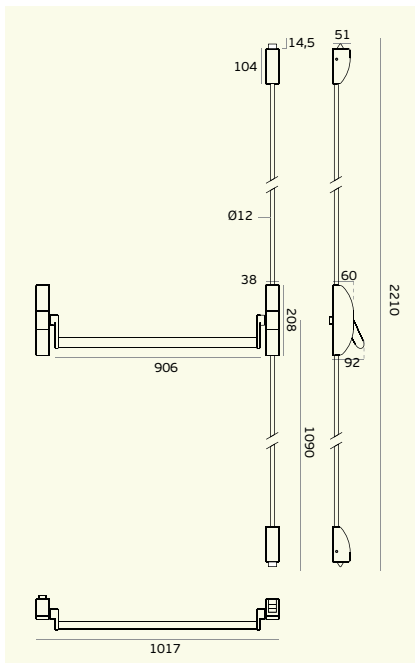

EN 1.4301
IN.20.954

RAL 9006
FA.20.954



BARRAS ANTI-PÂNICO PARA FECHADURA DE EMBUTIR / PANIC EXIT DEVICES FOR MORTISE LOCK / DISPOSITIVOS ANTIPÁNICO PARA CERRADURA DE EMBUTIR /

IN.20.957

Barra Anti-Pânico Reversível para porta de 1 Folha. Sem trinco lateral. Aplicável com fechadura de embutir (IN.20.960/960.C). Abertura por chave através do exterior. Puxador Rotativo com placa e cilindro não incluídos /

Reversible antipanic door Lock for Single Doors. Without side latch. Applicable with mortice lock (IN.20.960/960.C). Opening by key from the outside. Lever handle with plate and cylinder not included /

Cerradura Antipánico Reversible para Puertas de 1 Hoja. Sin Picaporte basculante. Aplicable con cerradura de embutir (IN.20.960/960.C). Apertura por llave por el exterior. Manilla, placa yz no inclusos.

Material: EN 1.4301

Satinado / Satin / Satin

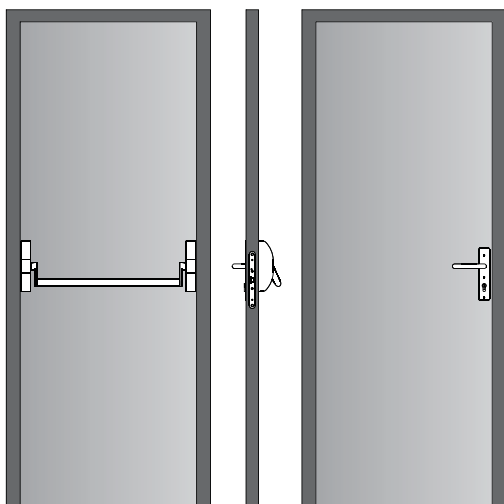
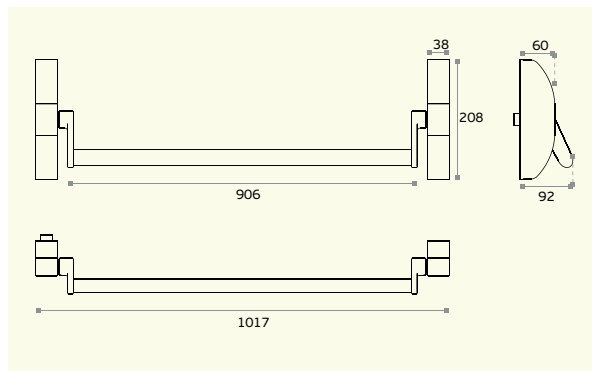

3 7 6 B 1 3 2 2 A A

IN.03.950.PZ.S

**Placa sem mola interior, com anilha de segurança.
Para aplicar com fechadura IN.20.960/960.C.
Cilindro não incluído. /**

Plate without interior spring, with security washer.
Applicable with mortice lock IN.20.960/960.C.
Cylinder not included. /

Placa sin resorte interior, con arandella de seguridad.
Aplicable con cerradura de embutir IN.20.960/960.C.
Cilindro no incluído. /

Material: EN 1.4301
Satinado / Satin / Satin

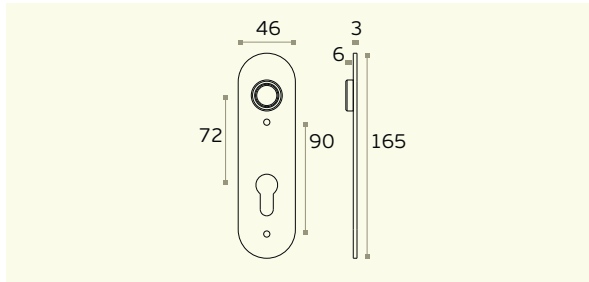

IN.03.230

**Placa cega com mola interior,
Para aplicar com fechadura IN.20.960 / 960.C
Puxador incluído. /**

Blind plate with interior spring.
Applicable with mortice lock IN.20.960 / 960.C
Lever handle included. /

Placa ciega con resorte interior.
Aplicable con cerradura de embutir IN.20.960 / 960.C
Manilla incluida. /

Material: EN 1.4301
Satinado / Satin / Satin

IN.03.230.PZ

**Placa com entrada para cilindro europeu com
mola interior. Para aplicar com fechadura
IN.20.960 / 960.C Puxador incluído. /**

Plate for european cylinder with interior spring.
Applicable with mortice lock IN.20.960 / 960.C
Lever handle included. /

Placa con bocallave de cilindro europeo resorte
interior. Aplicable con cerradura de embutir
IN.20.960 / 960.C Manilla incluida. /

Material: EN 1.4301
Satinado / Satin / Satin



BARRAS ANTI-PÂNICO PARA FECHADURA DE EMBUTIR / PANIC EXIT DEVICES FOR MORTISE LOCK / DISPOSITIVOS ANTIPÁNICO PARA CERRADURA DE EMBUTIR /

IN.20.960

Fechadura de embutir corta fogo.

Funciona com barra antipânico IN.20.957 /

Fire proof mortise lock.

antipanic device IN.20.957

Cerradura de embutir cortafuego. Funciona con
dispositivo antipánico IN.20.957.

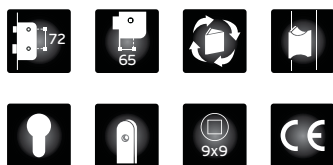
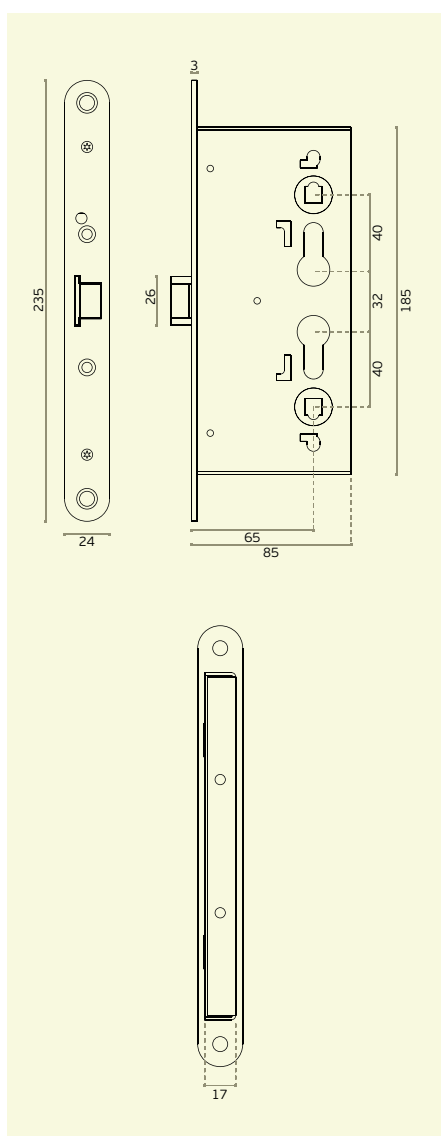

IN.20.960.C

Contra fechadura de embutir corta fogo.
Com tranças verticais

Funciona com a fechadura IN.20.960 e
barra antipânico IN.20.957 /

Fire proof mortice strike lock. With vertical rods
Works with lock IN.20.960 and antipanic device
IN.20.957/

Contracerradura de embutir cortafuego.
Funciona con cerradura IN.20.960 y dispositivo
antipánico IN.20.957.

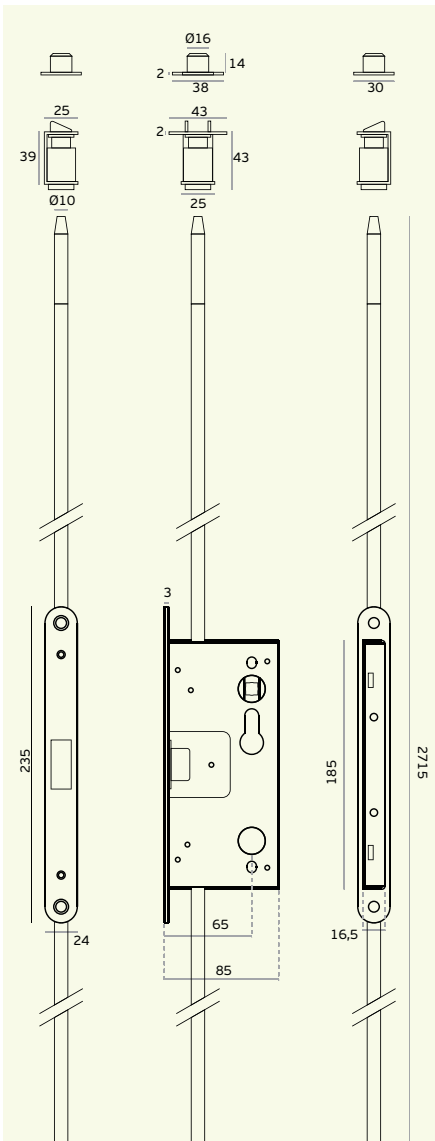

BARRAS ANTI-PÂNICO PARA PORTAS DE VIDRO / PANIC EXIT DEVICES FOR GLASS DOORS / DISPOSITIVOS ANTIPÁNICO PARA PUERTAS DE CRISTAL.



■
Barras Anti-pânico /
Panic exit devices /
Dispositivos antipánico.

H/1231



BARRAS ANTI-PÂNICO PARA PORTAS DE VIDRO / PANIC EXIT DEVICES FOR GLASS DOORS / DISPOSITIVOS ANTIPÁNICO PARA PUERTAS DE CRISTAL.

IN.20.951.K1

Barra Anti-Pânico Reversível para porta de 1 Folha. Fecho através de Trinco Lateral. Sem funcionamento através do exterior /

Antipanic Reversible Lock for Single Doors. Closing System trough a Side Latch. Without Access from External Side /

Cerradura Antipánico Reversible para Puertas de 1 Hoja. Cierre por Picaporte Basculante Lateral. Sin Funcionamiento por el Exterior /

Material: EN 1.4301

Satinado / Satin / Satin

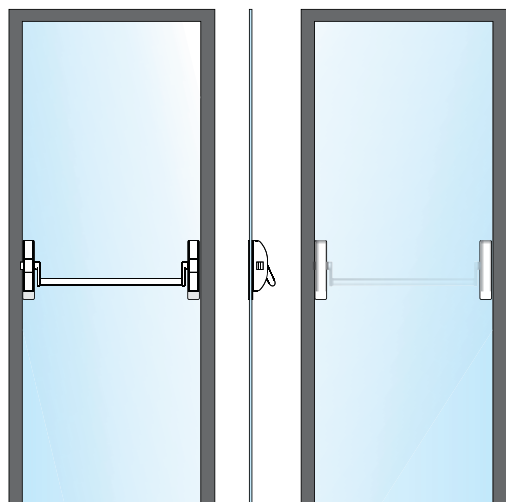
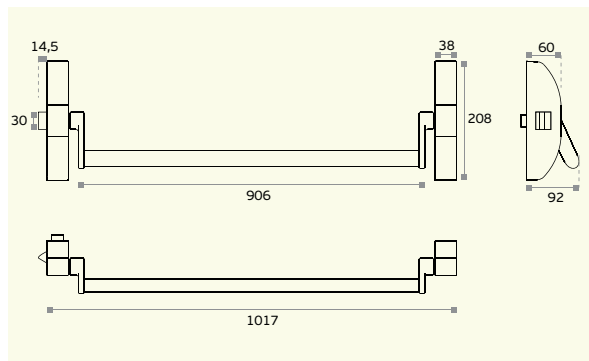

IN.20.952.K2

Barra Anti-Pânico Reversível para porta de 1 Folha. Fecho através de Trinco Lateral. Abertura por chave através do exterior. Puxador Rotativo com placa e cilindro incluídos /

Antipanic Reversible Lock for Single Doors. Closing System through a Side Latch. Opening by key from the outside. Lever handle with plate and cylinder included /

Cerradura Antipánico Reversible para Puertas de 1 Hoja. Cierre por Picaporte Basculante Lateral. Apertura por llave por el exterior. Manilla, placa y cilindro incluidos.

Material: EN 1.4301
Satinado / Satin / Satin

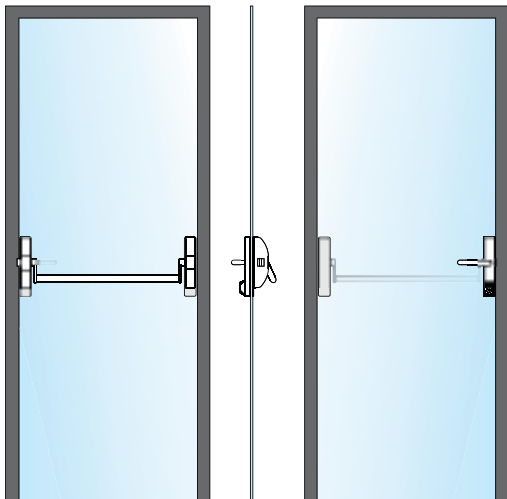
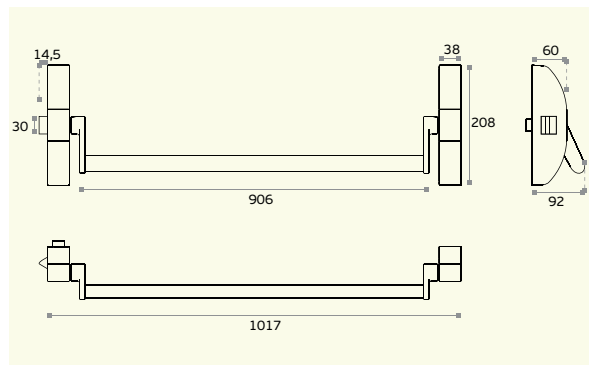

BARRAS ANTI-PÂNICO PARA PORTAS DE VIDRO /

PANIC EXIT DEVICES FOR GLASS DOORS /

DISPOSITIVOS ANTIPÁNICO PARA PUERTAS DE CRISTAL.

IN.20.953.K3

Barra Anti-Pânico reversível com fecho através de Trinco Superior e Inferior.
Sem funcionamento pelo exterior

Antipanic Lock with Closing System trough Top and Down Bolts.
 Without function from the outside /

Cerradura Antipánico con Cierre por Picaporte Alto y Bajo
 Sin funcion por el lado exterior

Material: EN 1.4301
 Satinado / Satin / Satin

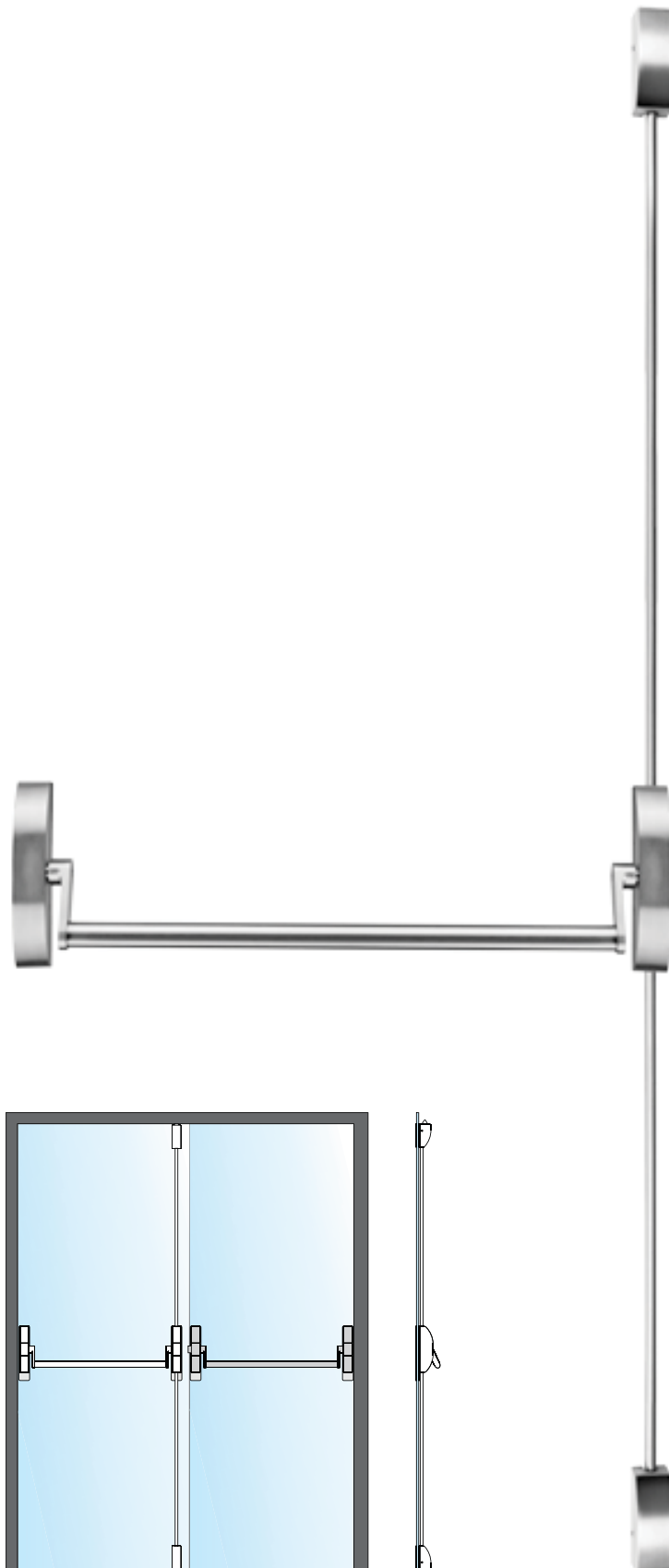
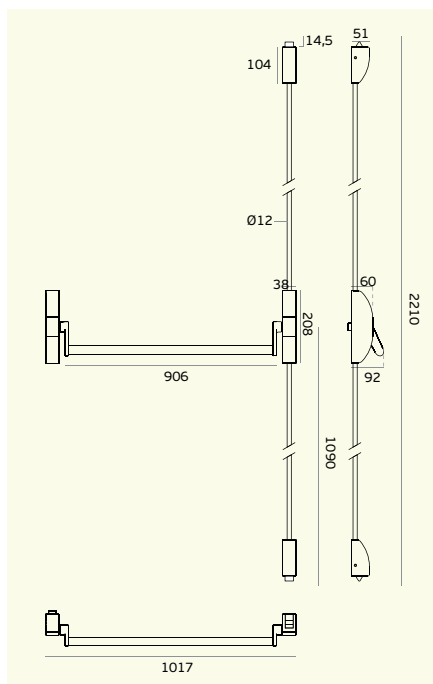

IN.20.954.K4

**Barra Anti-Pânico reversível com fecho através de Trinco Superior e Inferior.
Abertura por chave ou puxador através do exterior.
Puxador com placa e cilindro incluídos /**

Antipanic Lock with Closing System trough Top and Down Bolts. Opening by key and lever handle from the outside. Lever handle with plate and cylinder included /

Cerradura Antipánico con Cierre por Picaporte Alto y Bajo. Apertura por llave y manilla por el exterior. Manilla, placa y cilindro incluidos.

Material: EN 1.4301

Satinado / Satin / Satin

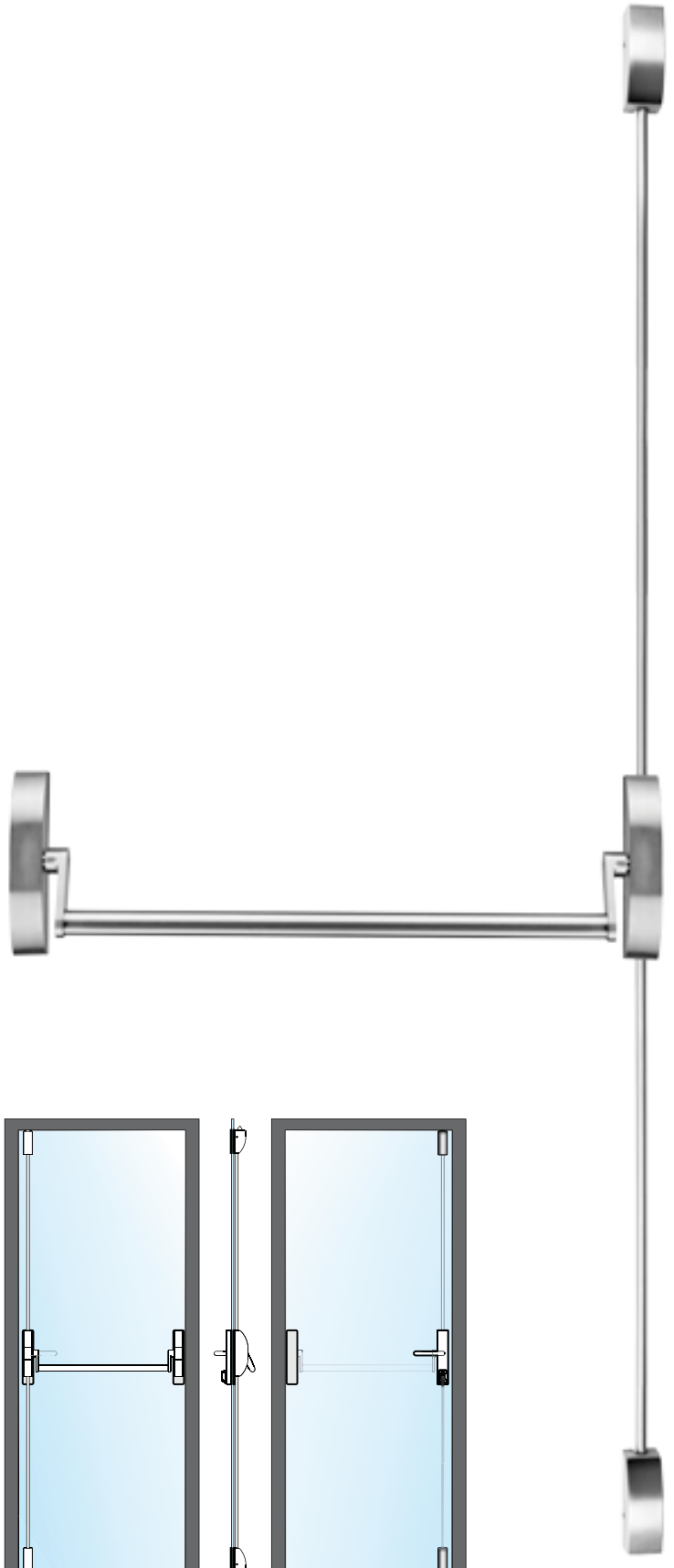
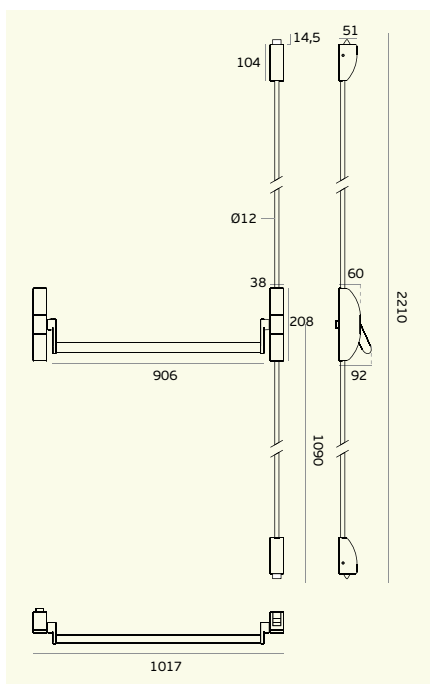

Acessórios para Barras Anti-pânico

Panic exit devices Accessories / Accesorios para Dispositivos antipánico.

IN.19.523.10/30

Meio cilindro para aplicar com fechadura
IN.20.960/950 . Chave standard /
Half cylinder to install with lock IN.20.960/950.
Standard key /
Medio cilindro para aplicar con cerradura
IN.20.960/950. llave standard /



IN.19.524.10/40

Meio cilindro para aplicar com fechadura
IN.20.960/950 . Chave de segurança /
Half cylinder to install with lock IN.20.960/950.
Security key /
Medio cilindro para aplicar con cerradura
IN.20.960/950. llave de seguridad /



IN.19.DPS.11/31

Meio cilindro para aplicar com placa
IN.20.960/950 . /
Half cylinder to install with plate IN.20.960/950. /
Medio cilindro para aplicar con placa IN.20.960/950.



IN.19.3KS.11/31

Meio cilindro para aplicar com placa
IN.20.960/950 . /
Half cylinder to install with plate IN.20.960/950. /
Medio cilindro para aplicar con placa IN.20.960/950.



Accessórios para Barras Anti-pânico

Panic exit devices Accessories / Accesorios para Dispositivos antipánico.

IN.20.962

Trancas verticais para portas superior a 2200mm. até 3140mm. Aplicável com IN.20.953/954. /

Vertical rods for doors higher than 2200 mm. until 3140mm. Apliable with IN.20.953/954. /

Fallebas para puertas superiores a 2200 mm hasta 3140mm. Aplicable con IN.20.953/954. /

Material: EN 1.4301
 Satinado / Satin / Satin



IN.20.961

Barra de apoio horizontal oval com 1400mm /

Oval shaped horizontal bar with 1400mm. /

Barra horizontal ovalada con 1400mm /

Material: EN 1.4301
 Satinado / Satin / Satin

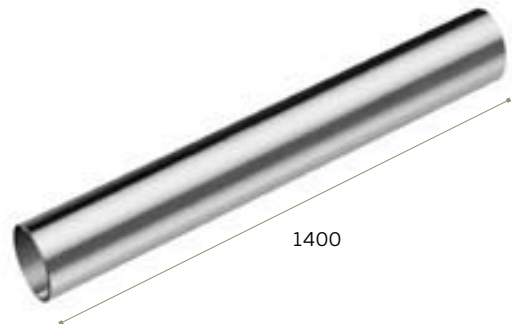

IN.08.CP

Quadra interrompida 8x8mm nas extremidades e 9x9mm. no centro para fechaduras anti-pânico /

Interrupted zinc plated sprindle 8x8mm. in the end and 9x9mm. in the middle to use in antipanic locks. /

Cuadradillo interrumpido de acero zincado 8x8mm en los topes y 9x9mm. no mediano para aplicar en cerraduras anti-panico.

IN.08.QIFAP.8

Quadra interrompida 8x8mm para fechaduras anti-pânico /

Interrupted zinc plated sprindle 8x8mm. to use in antipanic locks. /

Cuadradillo interrumpido de acero zincado 8x8mm para aplicar en cerraduras anti-panico.

IN.08.QIFAP.9

Quadra interrompida 9x9mm para fechaduras anti-pânico /

Interrupted zinc plated sprindle 9x9mm. to use in antipanic locks. /

Cuadradillo interrumpido de acero zincado 9x9mm para aplicar en cerraduras anti-panico.



H/1238

■■■
Sistemas de fecho /
Locking systems /
Sistemas de cierre

■
Molas de Porta /
Door Closers /
Cierra Puertas.

■
www.jnf.pt

MOLAS DE PORTA / DOOR CLOSERS / CIERRA PUERTAS



Molas de Porta /
Door Closers /
Cierra Puertas.

H/1239



MOLAS DE PORTA / DOOR CLOSERS / CIERRA PUERTAS



Marcação CE /
CE Marking /
Marcado CE.



Corta Fogo /
Fire tested /
Corta fuego.



Certificadas segundo a Norma Europeia /
Certified Accordingly to the European Norm /
Certificadas segundo la Norma Europea.



Certificadas segundo a Norma Europeia /
Certified Accordingly to the European Norm /
Certificadas segundo la Norma Europea.



Sistema CAM /
CAM System /
sistema CAM.



Cremalheira e pinhão /
Rack and pinion /
Piñón y cremallera.



ICONOGRAFIA - CARACTERÍSTICAS TÉCNICAS / ICONOGRAPHY - TECHNICAL DATA / ICONOGRAFIA - CARACTERISTICAS TECNICAS



Respeita os requisitos para pessoas com mobilidade condicionada /
Help to meet the disabled discrimination act requirements /
Cumple con los requisitos para los minusválidos.



Largura máxima de porta /
Maximum door width /
Ancho máximo de puerta.



Carga máxima /
Maximum load /
Carga máxima.



Garantia /
Warranty /
Garantía.



Força /
Power /
Fuerza.



Força ajustável /
Adjustable power /
Fuerza ajustable.



MOLAS DE PORTA / DOOR CLOSERS / CIERRA PUERTAS /

As molas de porta JNF são certificadas segundo a norma Europeia EN 1154.

A norma EN 1154 classifica as molas de porta segundo vários parâmetros representados por um sistema de código de 6 dígitos.

The JNF door closers are certified according to European standard EN 1154.

Standard EN 1154 classifies the door closers according to some parameters represented for a code system with 6 digits.

Los cierra puertas JNF son certificados según la normativa EN 1154.

La normativa europea EN 1154 clasifica los cierra puertas según algunos parámetros representados por un sistema de código con 6 dígitos.

Tipo de utilização Type of use / Tipo de uso

Grade 3:
**Molas de porta
com abertura
superior a 105° /**
Door closer with
opening over 105° /
Cierra puerta
superior a 105°

Grade 4:
**Molas de porta
com abertura
superior a 180° /**
Door closer with
opening over 180° /
Cierra puerta
superior a 180°

Força/ Largura recomendada Power / Recommended wide Fuerza / Anchura recomendada

Grade 1 - ≤ 750mm
Grade 2 - 850mm
Grade 3 - 950mm
Grade 4 - 1100mm
Grade 5 - 1250mm
Grade 6 - 1400mm
Grade 7 - 1600mm

Segurança / Safety / Seguridad:

**Todas as molas de
porta devem
preencher os
requisitos de
segurança**

All the door closers
are required to
satisfy the essential
requirements
Todos los cierra
puertas tienen de
satisfacer los
requisitos de
seguridad
Grade 1



DIN 1670

**Número de ciclos/
Number of test cycles /
Número de ciclos
Existe apenas um
teste de duração
aplicável às molas
de porta /**
Only one test duration
is identified for the door
closers manufactured to
this standard. /
Solamente una duración
de la prueba se
identifica para
los cierra puertas.
**-Grade 8 - 500.000
cycles**

DIN 1634

**Resistência ao fogo /
Fire behaviour /
Resistencia al fuego
-Grade 0 - Não
aplicável em portas
corta fogo/
Not suitable for fire
proof doors /
No aplicable en puertas
cortafuego
-Grade 1 - aplicável em
portas corta fogo /
Suitable for
fire proof doors /
Aplicable en puertas
corta fuego puerta 90min**

**Resistencia à corrosão /
Corrosion resistance /
Resistencia a la corrosion:**

**-Grade 0 - Resistência à
corrosão não definida**
No defined corrosion resistance
Resistencia a la corrosion non
definida
-Grade 1 - Fraca resistência
Mild resistance
Resistencia suave
**-Grade 2 - Resistência
moderada**
Moderate resistance
Resistencia moderada
-Grade 3 - Forte resistência
High resistance
Fuerte resistencia
**-Grade 4 - Resistência muito
forte**
Very high resistance
Resistencia muy fuerte

	TIPO / TYPE / TIPO		Molas de sobrepor / overhead door closer / Cierra puertas de sobreponer					Molas ocultas / Concealed door closer / Cierra puertas ocultos					
	UTILIZAÇÃO / USE / USO		21.775	21.770	21.765	21.760	21.610	21.600	21.813	21.812	21.810	21.802	21.801
	Residencial / Residential		•	•	•	•	•	•	•	•	•	•	•
	Comercial		•	•	•	•	•	•	•	•	•	•	•
	Institucional / Institutional		•	•	•		•		•	•	•		
	Força / Power Fuerza - MAX	Largura Width Anchura MAX											
	2	850mm	•		•	•	•	•	•	•	•	•	•
	3	950mm	•	•	•	•	•	•	•	•			
	4	1100mm	•	•	•	•	•	•	•	•			
	5	1250mm		•	•		•						
	MAX. 60kg										•	•	
	MAX. 80kg		•			•							
	MAX. 100kg			•	•		•	•					
	MAX. 130kg								•	•	•		
	Fire rated		•	•	•	•	•	•	•	•	•	•	•
	CE Marking		•	•	•	•	•	•					
EN 1154	EN 1154 - DIN 1154		•	•	•	•	•	•	•	•	•	•	•
EN 1670	EN 1670 - DIN 1670		•	•	•	•	•	•	•	•	•	•	•
EN 1634	EN 1634 - DIN 1634		•	•	•	•	•	•	•	•	•	•	•
	Mobilidade condicionada / Discrimination act requirements		•						•	•			
	Sistema CAM / CAM System		•						•	•			
	Cremalheira e pinhão / Rack and pinion / Piñón y cremallera			•	•	•	•	•			•	•	•
	Dupla acção / double action/ Action doble								•				
	Retenção na abertura / hold open / retención en la apertura.		○	○	○	○	○	○	○	○	○	○	○

DECLARAÇÃO DE DESEMPENHO / MARCAÇÃO CE

DECLARATION OF PERFORMANCE (DOP) / CE MARKING/

DECLARACIÓN DE PRESTACIONES / MARCADO CE

Declaração de Desempenho / Marcação CE

O Regulamento (UE) n.º 305/2011 entrou em vigor em 1 de Julho de 2013, o qual estabelece condições harmonizadas para a comercialização dos produtos de construção e revoga a Directiva 89/106/CEE.

O presente regulamento obriga os fabricantes de produtos de construção a elaborar uma declaração de desempenho quando um produto de construção abrangido por uma norma harmonizada ou conforme com uma Avaliação Técnica Europeia emitida para esse produto.

Ao fazer a declaração de desempenho, o fabricante assume a responsabilidade legal pela conformidade do produto de construção com o desempenho declarado. Se a declaração de desempenho não tiver sido efetuada pelo fabricante, a marcação CE não pode ser aposta.

As molas de porta aéreas só podem apresentar a marcação CE quando as mesmas têm utilização prevista em portas corta-fogo/fumo e em portas destinadas a saídas de emergência. Neste caso deve-se seguir o Sistema 1 de avaliação e verificação da regularidade do desempenho.

Norma harmonizada para molas de porta aéreas: EN1154 – Dispositivos de fechos de porta com amortecimento.

Declaration of Performance (DoP) / CE Marking

The Regulation (EU) No 305/2011 entered in to force on July 1, 2013, laying down harmonised conditions for the marketing of construction products and repealing Council Directive 89/106/EEC.

This regulation requires manufacturers of construction products to draw up a declaration of performance when a construction product covered by a harmonised standard, or complies with an European Technical Assessment issued for this product.

Making a declaration of performance, the manufacturer assumes legal responsibility for the conformity of the product with the declared performance. If the performance statement hasn't been made by the manufacturer, CE marking cannot be affixed.

The door closers only can have the CE marking when they have and intended use in fire doors / smoke and emergency exit doors.

In this case should follow the System 1 of assessment and verification of constancy of performance.

Harmonised Standard for door closers: EN1154 - Controlled door closing devices

Declaración de Prestaciones / Mercado CE

El Reglamento (UE) nº 305/2011 entró en vigor en 1 Julio 2013, que establece condiciones armonizadas para la comercialización de los productos de construcción y se deroga la Directiva 89/106 / CEE.

Esta regulación exige a los fabricantes de productos de construcción a elaborar una declaración de prestaciones cuando un producto de construcción cubierto por una norma armonizada, o cumple con una evaluación técnica europea emitida para este producto.

Hacer una declaración de prestaciones, el fabricante asume la responsabilidad legal de la conformidad del producto con las prestaciones declaradas. Si la declaración de prestaciones no hay sido hecha por el fabricante, el marcado CE no puede ser fijado.

Las cierrapuertas solo pueden tener el marcado CE cuando tienen un uso destinado en las puertas corta-fuego/humo y puertas destinadas a salida de emergencia.

En este caso, debe seguir el Sistema 1 de evaluación y verificación de la constancia de las prestaciones.

Norma armonizada para Cierrapuertas : EN1154 - Dispositivos de cierre controlado de puertas



EC CERTIFICATE OF CONFORMITY

Number: 1121 - CPD – AD0268

In compliance with Directive 89/106/EEC of the Council of European Communities of 21 December 1988 on the approximation of laws, regulations and administrative provisions of the Member States relating to construction products (Construction Products Directive - CPD), amended by the Directive 93/68/EEC of the Council of European Communities of 22 July 1993, it is confirmed that the following products are subject to factory production control procedures and are submitted by the manufacturer to further testing of samples taken at the factory in accordance with a prescribed test plan. The stated Notified Certification Body has performed the initial type-testing for the relevant characteristics of the product, has conducted the initial inspection of the factory and the factory production control, and is responsible for the continuous surveillance, assessment and approval of the factory production control.

construction product : **JNF 21.765.BS Overhead Door Closer**

placed on the market by:

Company:

J NEVES & FILHOS, S.A

Address:

**Rua das Mimosas, 849/851 Zona Industrial das Mimosas,
Sao Pedro da Cova, 4424-909 GONDOMAR. Portugal.**

product classification:

4	8	5 2	1*	1	3
---	---	--------	----	---	---

intended use:

For use on fire/smoke compartmentation doors

particular conditions applicable: **Mounted in regular application only with adjustable latch action and backcheck.**

This document certifies that all the provisions concerning the attestation of conformity and product performance described in Annex ZA of the product standard

EN 1154:1996 + A1:2002

were applied and that the product fulfils all the prescribed requirements.

Notified Certification Body: **Warrington Certification Ltd**

EC Reference Number: **1121**

This certificate was first issued on 26/01/10 and remains valid as long as the conditions laid down in the harmonised technical specification above, or the product design, or the manufacturing conditions in the factory, or the FPC itself are not modified significantly, or at the latest 25/01/15.



A.G. Quinn

Manager – Warrington Certification Ltd.

References:

Mechanical test evidence: 189535/A
Factory references: JJ010

Fire test evidence: 190338
Classification report: N/A

* The referenced reports detail the precise field of application for fire/smoke door use

DECLARAÇÃO DE DESEMPENHO / MARCAÇÃO CE DECLARATION OF PERFORMANCE (DOP) / CÉ MARKING/ DECLARACIÓN DE PRESTACIONES / MARCADO CE



Page 1 of 1

EC CERTIFICATE OF CONFORMITY
Number: 1121 - CPD - A00269

In compliance with Directive 90/269/EEC of the Council of European Communities of 21 December 1989 on the approximation of laws, regulations and administrative provisions of the Member States relating to construction products (Construction Products Directive - CPD), amended by the Directive 93/68/EEC of the Council of European Communities of 23 July 1993, it is certified that the following products are subject to factory production control procedures and are submitted by the manufacturer to further testing or sampling tests at the factory in accordance with a prescribed test plan. The stated Notified Certification Body has performed the initial type-testing for the relevant characteristics of the product. The notified CE Marking Inspector of the factory and the factory production control, and is responsible for the continuous surveillance, assessment and approval of the factory production control.

construction product: **JNF 21.760.BS Overhead door closer.**

placed on the market by:
Company: **J NEVES & FILHOS, S.A**
Address: **Rua das Mimosas, 845/851 Zona Industrial das Mimosas, São Pedro da Cova, 4424-909 GONDOMAR, Portugal.**

product identification: **4 8 2 1 1 3**

intended use: **For use on fire 1 smoke compartment doors.**

particular conditions applicable: **See 2.6 in Regular fitting position with adjustable lock actuator only. See 2 in Periodic open fitting operation with adjustable lock actuator & back stress - 10° Max opening angle.**

This document certifies that all the provisions concerning the allocation of conformity and product performance described in Annex 20 of the product standard

EN 1564:1996 + A1:2002

were applied and that the product fulfils all the prescribed requirements.

Notified Certification Body: **Warrington Certification Ltd** EC Reference Number: **1121**

This certificate was first issued on 28/07/10 and remains valid as long as the conditions set down in the harmonized technical specification above, or the product design, or the manufacturing conditions in the factory, or the TTC itself are not modified significantly, or if the value 28/07/10.

 
Manager - Warrington Certification Ltd.

References:
Mechanical test standard: **EN60336** For test standard: **EN60336**
Factory reference: **2612** Classification report: **Yes**
* The referenced reports detail the precise field of application for Performance class use.

Page 1 of 1

EC CERTIFICATE OF CONFORMITY
Number: 1121 - CPD - A00270

In compliance with Directive 90/269/EEC of the Council of European Communities of 21 December 1989 on the approximation of laws, regulations and administrative provisions of the Member States relating to construction products (Construction Products Directive - CPD), amended by the Directive 93/68/EEC of the Council of European Communities of 23 July 1993, it is certified that the following products are subject to factory production control procedures and are submitted by the manufacturer to further testing or sampling tests at the factory in accordance with a prescribed test plan. The stated Notified Certification Body has performed the initial type-testing for the relevant characteristics of the product. The notified CE Marking Inspector of the factory and the factory production control, and is responsible for the continuous surveillance, assessment and approval of the factory production control.

construction product: **JNF 21.770.BS Overhead door closer.**

placed on the market by:
Company: **J NEVES & FILHOS, S.A**
Address: **Rua das Mimosas, 845/851 Zona Industrial das Mimosas, São Pedro da Cova, 4424-909 GONDOMAR, Portugal.**

product identification: **4 8 2 1 1 3**

intended use: **For use on fire 1 smoke compartment doors.**

particular conditions applicable: **See 1 to 5 in Standard position with adjustable backstress, no lock.**

This document certifies that all the provisions concerning the allocation of conformity and product performance described in Annex 20 of the product standard

EN 1564:1996 + A1:2002

were applied and that the product fulfils all the prescribed requirements.

Notified Certification Body: **Warrington Certification Ltd** EC Reference Number: **1121**

This certificate was first issued on 28/07/10 and remains valid as long as the conditions set down in the harmonized technical specification above, or the product design, or the manufacturing conditions in the factory, or the TTC itself are not modified significantly, or if the value 28/07/10.

 
Manager - Warrington Certification Ltd.

References:
Mechanical test standard: **EN60336** For test standard: **EN60336**
Factory reference: **2612** Classification report: **Yes**
* The referenced reports detail the precise field of application for Performance class use.

417

**Braço Design em aço
Inoxidável, casquilhos em
liga de nylon com fibra de
vidro auto-lubrificante. Braço
deslizante sem retenção /**
Design arm made in stainless steel,
self lubricating inserts made in
nylon and fiberglass alloy sliding
arm without retaining /
Brazo diseño en acero inoxidable,
casquillos autolubricados en
aleación de nylon y fibra de
vidrio. Brazo deslizante sin
retención.











**Tampa reforçada em aço
inoxidável 1,5 mm de espessura /**
Reinforced stainless steel cover with
1,5mm thickness /
Cubierta reforzada en acero
inoxidable con 1,5mm de espesor.

IN.21.775.BD POWER 4-2		
IN.21.770.BD POWER 5-3		
IN.21.765.BD POWER 5-2		
IN.21.760.BD POWER 3		

ÍNDICE - MOLAS DE PORTA DE SOBREPOR / INDEX - OVERHEAD DOOR CLOSER / ÍNDICE - PUERTAS DE SOBREPONER



IN.21.775.BS.Q POWER 4-2	 
IN.21.765.BS.Q POWER 5-2	
IN.21.760.BS.Q POWER 4-2	

IN.21.775.BS POWER 4-2	 
IN.21.770.BS POWER 5-3	
IN.21.765.BS POWER 5-2	
IN.21.760.BS POWER 4-2	

IN.21.____.BS





IN.21.____.BS.Q



Mola de porta com tampa e braço standard em aço inox / Door closer with stainless steel cover and standard arm / Cierra puertas con cubierta y brazo estándar en acero inoxidable.

IN - Tampa e braço em aço Inoxidável / Cover and arm in stainless steel / Cubierta y brazo en acero inoxidable

BS - Braço standard / Standard arm / Brazo estándar



ML.21.775.BS.R POWER 4-2	 
ML.21.765.BS.R POWER 5-2	
ML.21.760.BS.R POWER 4-2	

ML.21.770.BS POWER 5-3	
ML.21.765.BS POWER 5-2	
ML.21.760.BS POWER 4-2	

ML.21.____.BS.R

Mola de porta com tampa e braço standard RAL 9006 / Door closer with cover and standard arm RAL 9006 / Cierra puertas con cubierta y brazo estándar RAL 9006 .

ML.21.____.BS

Mola de porta com braço standard / Door closer with standard arm / Cierra puertas con brazo estándar.



IN.21.____.BA

IN.21.____.BA.Q

**Mola de porta com tampa em aço
Inox e braço antivandalismo /**
Door closer with stainless steel
cover and sliding arm /
Cierra puertas con cubierta
en acero inoxidable y brazo
antivandalismo.

IN.21.775.BA.Q POWER 4-2	
IN.21.765.BA.Q POWER 5-2	
IN.21.760.BA.Q POWER 3	

IN.21.775.BA POWER 4-2	
IN.21.770.BA POWER 5-3	
IN.21.765.BA POWER 5-2	
IN.21.760.BA POWER 3	

BA - Braço Anti-vandalismo / sliding arm / Brazo antivandalismo

ML - Tampa e braço RAL 9006 / Cover and arm in RAL 9006 / Cubierta y brazo en RAL 9006



ML.21.____.BA.R

**Mola de porta com tampa e
braço antivandalismo RAL 9006**
/ Door closer with cover and sliding
Arm in RAL 9006 / Cierra puertas
con cubierta y brazo antivandalismo
RAL 9006 .

ML.21.____.BA

**Mola de porta standard com
braço antivandalismo RAL 9006**
/ Standard Door closer with sliding
arm RAL 9006 / Cierra puertas
estandar y brazo antivandalismo
RAL 9006 .

ML.21.775.BA.R POWER 4-2	
ML.21.765.BA.R POWER 5-2	
ML.21.760.BA.R POWER 3	

ML.21.770.BA POWER 5-3	
ML.21.765.BA POWER 5-2	
ML.21.760.BA POWER 3	

ÍNDICE - MOLAS DE PORTA DE SOBREPOR /

INDEX - OVERHEAD DOOR CLOSER /

ÍNDICE - PUERTAS DE SOBREPONER

**ML.21.610**

Mola de porta com braço standard RAL 9006 /
 Door closer with standard arm RAL 9006 /
 Cierra puertas con brazo estándar RAL 9006 .

Ajuste de força por mola /
 Power adjustment by spring /
 Regulación de fuerza por muelle.

ML.21.610 - POWER 5-2**ML.21.600**

Mola de porta com braço standard RAL 9006 /
 Door closer with standard arm RAL 9006 /
 Cierra puertas con brazo estándar RAL 9006 .

Ajuste de força por mola /
 Power adjustment by spring /
 Regulación de fuerza por muelle.

ML.21.600 - POWER 4-2**21.205**

Tampa em RAL 9006 /
 Cover in RAL 9006 /
 Cubierta en RAL 9006



IN.21.812 / 813

Mola de porta oculta com sistema de "CAM"
Porta ≥ 40 mm de espessura / Concealed door
closer with "CAM" action mechanism. Door
thickness ≥ 40 mm / Cierra puertas oculto con
sistema "CAM". Puerta ≥ 40 mm de espesor.

IN.21.812/813 - POWER 4-2



IN.21.810

Mola de porta oculta. Porta ≥ 40 mm de
espessura / Concealed door closer. Door
thickness ≥ 40 mm / Cierra puertas oculto.
Puerta ≥ 40 mm de espesor.

IN.21.810 - POWER 4-2



IN.21.802

Mola de porta oculta. Porta ≥ 35 mm de
espessura / Concealed door closer. Door
thickness ≥ 35 mm / Cierra puertas oculto.
Puerta ≥ 35 mm de espesor.

IN.21.802 - POWER 3



IN.21.801

Mola de porta oculta. Porta ≥ 40 mm de
espessura / Concealed door closer. Door
thickness ≥ 40 mm / Cierra puertas oculto.
Puerta ≥ 40 mm de espesor.

IN.21.801 - POWER 3

SÉRIE 775 - INOX

775 SERIES - INOX / SERIE 775 - INOX



EN1154 48⁴₂ 1113



IN.21.775.BD

EN 1.4301 Satinado / Satin / Satin

Mola de porta aérea hidráulica de sobrepor
Braço anti-vandalismo
Força ajustável: 2-4
Largura máxima de porta: 1100 mm
Peso máximo de porta: 80 kg
Ajuste de força por mola
Mecanismo CAM
Velocidade de fecho ajustável por válvula
Velocidade de fecho final ajustável por válvula
Ângulo de abertura 180°
Mola reversível
Certificado Corta fogo
Marcação CE

Hydraulic overhead door closer
Sliding Arm
Adjustable Power: 2-4
Maximum door width: 1100 mm
Maximum door weight: 80 kg
Power adjustment by spring
CAM action mechanism
closing speed adjustable by valve
Latching speed adjustable by valve
Opening angle 180°
Reversible door closer
Certified Fire proof
CE marking

Cierra puertas hidráulico de sobreponer
Braço antivandalismo
Fuerza ajustable: 2-4
Ancho máximo de puerta: 1100 mm
Peso máximo de puerta: 80 kg
Regulación de fuerza por muelle
Mecanismo de CAM
Velocidad de cierre ajustable por válvula
Velocidad de golpe final ajustable por válvula
Ángulo de apertura 180°
Cierra puertas reversible
Certificada corta fuego
Marcación CE





EN1154

4	8
4	2

1	1	3
---	---	---



IN.21.775.BA.Q

EN 1.4301 Satinado / Satin / Satin

Mola de porta aérea hidráulica de sobrepor
Braço anti-vandalismo
Força ajustável: 2-4
Largura máxima de porta: 1100 mm
Peso máximo de porta: 80 kg
Ajuste de força por mola
Mecanismo CAM
Velocidade de fecho ajustável por válvula
Velocidade de fecho final ajustável por válvula
Sistema de retenção na abertura : amovível
Ângulo de abertura 180°
Mola reversível
Certificado Corta fogo
Marcação CE

Hydraulic overhead door closer
Sliding Arm
Adjustable Power: 2-4
Maximum door width: 1100 mm
Maximum door weight: 80 kg
Power adjustment by spring
CAM action mechanism
closing speed adjustable by valve
Latching speed adjustable by valve
Hold open system: revolvable
Opening angle 180°
Reversible door closer
Certified Fire proof
CE marking

Cierra puertas hidráulico de sobreponer
Brazo antivandalismo
Fuerza ajustable: 2-4
Ancho máximo de puerta: 1100 mm
Peso máximo de puerta: 80 kg
Regulación de fuerza por muelle
Mecanismo de CAM
Velocidad de cierre ajustable por válvula
Velocidad de golpe final ajustable por válvula
Sistema de retención en la apertura: extraíble
Ángulo de apertura 180°
Cierra puertas reversible
Certificada corta fuego
Marcación CE



IN.21.775.BA



ML.21.775.BA.R



SÉRIE 775 - INOX

775 SERIES - INOX / SERIE 775 - INOX



EN1154 484113



IN.21.775.BS.Q

EN 1.4301 Satinado / Satin / Satin

Mola de porta aérea hidráulica de sobrepor
Braço standard sem retenção
Força ajustável: 2-4
Largura máxima de porta: 1100 mm
Peso máximo de porta: 80 kg
Ajuste de força por mola
Mecanismo CAM
Velocidade de fecho ajustável por válvula
Velocidade de fecho final ajustável por válvula
Ângulo de abertura 180°
Mola reversível
Certificado Corta fogo
Marcação CE

Hydraulic overhead door closer
Standard arm without retaining
Adjustable Power: 2-4
Maximum door width: 1100 mm
Maximum door weight: 80 kg
Power adjustment by spring
CAM action mechanism
closing speed adjustable by valve
Latching speed adjustable by valve
Opening angle 180°
Reversible door closer
Certified Fire proof
CE marking

Cierra puertas hidráulico de sobreponer
Brazo estandard sin retención
Fuerza ajustable: 2-4
Ancho máximo de puerta: 1100 mm
Peso máximo de puerta: 80 kg
Regulación de fuerza por muelle
Mecanismo de CAM
Velocidad de cierre ajustable por válvula
Velocidad de golpe final ajustable por válvula
Ángulo de apertura 180°
Cierra puertas reversible
Certificada corta fuego
Marcación CE



IN.21.775.BS



ML.21.775.BS.R

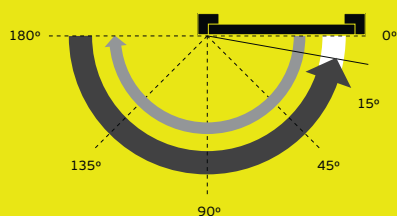

Abertura /
Opening /
Apertura.

Velocidade de fecho
Closing speed /
Velocidade de freno.

Velocidade do fecho final
Final closing speed /
Velocidade de golpe final.

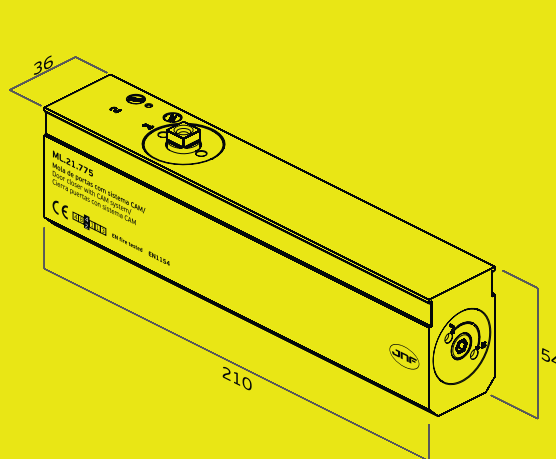

Final closing speed 2

Closing speed 1



Power
adjust



1 Braço standard INOX /
Stainless steel standard arm /
Brazo estándar INOX.

2 Braço standard RAL 9006 /
RAL 9006 standard arm /
Brazo estándar RAL 9006.

3 Braço Anti-vandalismo /
sliding arm /
Brazo antivandalismo.

4 Braço Design INOX /
Stainless steel sliding arm /
Brazo diseño INOX.

A Tampa reforçada em aço inoxidável /
Reinforced stainless steel cover /
Cubierta reforzada en acero inoxidable /

B Tampa em aço inoxidável /
Stainless steel cover /
Cubierta en acero inoxidable /

C Tampa em aço inoxidável /
Stainless steel cover /
Cubierta en acero inoxidable /

D Tampa RAL 9006 /
RAL 9006 cover /
Cubierta RAL 9006 /

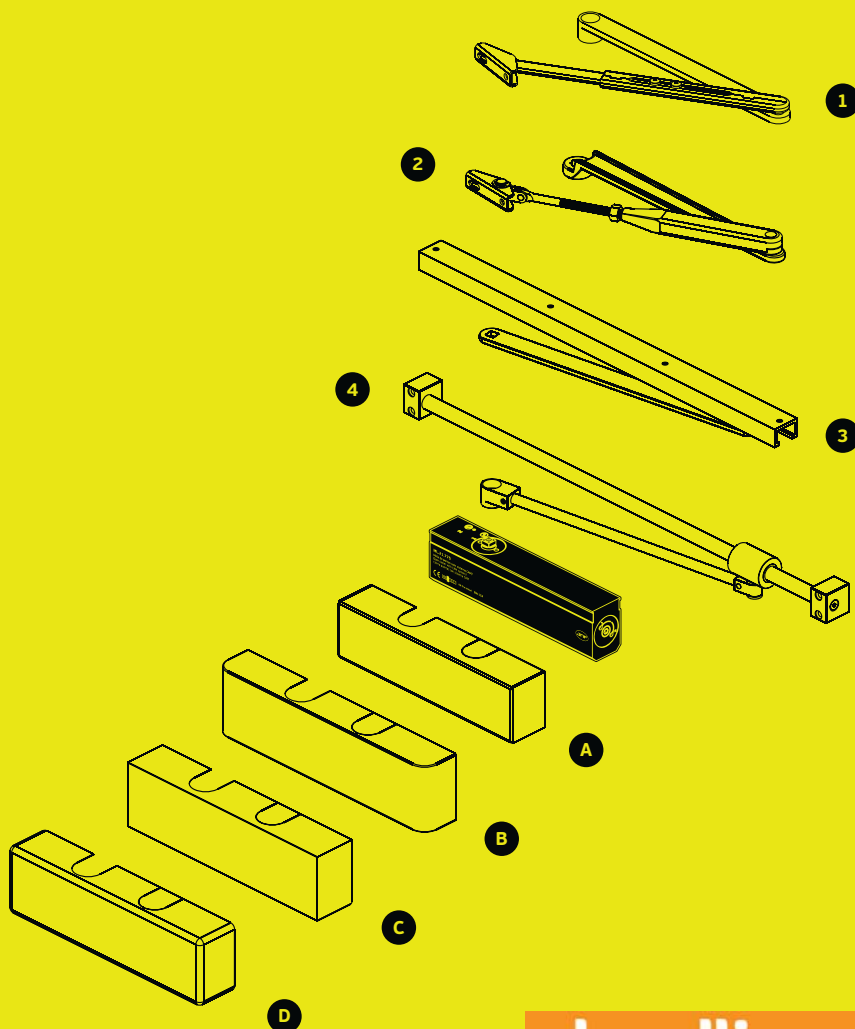

SÉRIE 770 - INOX

770 SERIES - INOX / SERIE 770 - INOX



EN1154 4|8|5|1|1|3



IN.21.770.BD

EN 1.4301 Satinado / Satin / Satin

Mola de porta aérea hidráulica de sobrepor
 Braço anti-vandalismo
 Força ajustável: 3-5
 Largura máxima de porta: 1250 mm
 Peso máximo de porta: 100 kg
 Ajuste de força por mola
 Mecanismo cremalheira e pinhão
 Válvula "back check" - travagem na abertura
 Velocidade de fecho ajustável por válvula
 Velocidade de fecho final ajustável por válvula
 Ângulo de abertura 180°
 Mola reversível
 Certificado Corta fogo
 Marcação CE

Hydraulic overhead door closer
 Sliding Arm
 Adjustable Power: 3-5
 Maximum door width: 1250 mm
 Maximum door weight: 100 kg
 Power adjustment by spring
 Rack and pinion mechanism
 Back check Valve
 closing speed adjustable by valve
 Latching speed adjustable by valve
 Opening angle 180°
 Reversible door closer
 Certified Fire proof
 CE marking

Cierra puertas hidráulico de sobreponer
 Brazo antivandalismo
 Fuerza ajustable: 3-5
 Ancho máximo de puerta: 1250 mm
 Peso máximo de puerta: 100 kg
 Regulación de fuerza por muelle
 Mecanismo de piñon y cremallera
 Válvula "back check" freno en la apertura
 Velocidad de cierre ajustable por válvula
 Velocidad de golpe final ajustable por válvula
 Ángulo de apertura 180°
 Cierra puertas reversible
 Certificada corta fuego
 Marcación CE





EN1154 4|8|5|1|1|3



IN.21.770.BA

EN 1.4301 Satinado / Satin / Satin

Mola de porta aérea hidráulica de sobrepor
Braço anti-vandalismo
Força ajustável: 3-5
Largura máxima de porta: 1250 mm
Peso máximo de porta: 100 kg
Ajuste de força por mola
Mecanismo cremalheira e pinhão
Válvula "back check" - travagem na abertura
Velocidade de fecho ajustável por válvula
Velocidade de fecho final ajustável por válvula
Sistema de retenção na abertura : amovível
Ângulo de abertura 180°
Mola reversível
Certificado Corta fogo
Marcação CE

Hydraulic overhead door closer
Sliding Arm
Adjustable Power: 3-5
Maximum door width: 1250 mm
Maximum door weight: 100 kg
Power adjustment by spring
Rack and pinion mechanism
Back check Valve
closing speed adjustable by valve
Latching speed adjustable by valve
Hold open system: revovable
Opening angle 180°
Reversible door closer
Certified Fire proof
CE marking

Cierra puertas hidráulico de sobreponer
Brazo antivandalismo
Fuerza ajustable: 3-5
Ancho máximo de puerta: 1250 mm
Peso máximo de puerta: 100 kg
Regulación de fuerza por muelle
Mecanismo de piñon y cremallera
Valvula "back check" freno en la apertura
Velocidad de cierre ajustable por válvula
Velocidad de golpe final ajustable por válvula
Sistema de retención en la apertura: extraíble
Ángulo de apertura 180°
Cierra puertas reversible
Certificada corta fuego
Marcación CE



ML.21.770.BA

SÉRIE 770 - INOX

770 SERIES - INOX / SERIE 770 - INOX



EN1154 4 8 5 1 1 1 3



IN.21.770.BS

EN 1.4301 Satinado / Satin / Satin

Mola de porta aérea hidráulica de sobrepor
Braço standard sem paragem
Força ajustável: 3-5
Largura máxima de porta: 1250 mm
Peso máximo de porta: 100 kg
Ajuste de força por mola
Mecanismo cremalheira e pinhão
Válvula "back check" - travagem na abertura
Velocidade de fecho ajustável por válvula
Velocidade de fecho final ajustável por válvula
Ângulo de abertura 180°
Mola reversível
Certificado Corta fogo
Marcação CE

Hydraulic overhead door closer
Standard arm without retaining
Adjustable Power: 3-5
Maximum door width: 1250 mm
Maximum door weight: 100 kg
Power adjustment by spring
Rack and pinion mechanism
Back check Valve
closing speed adjustable by valve
Latching speed adjustable by valve
Opening angle 180°
Reversible door closer
Certified Fire proof
CE marking

Cierra puertas hidráulico de sobreponer
Brazo estandard sin retención
Fuerza ajustable: 3-5
Ancho máximo de puerta: 1250 mm
Peso máximo de puerta: 100 kg
Regulación de fuerza por muelle
Mecanismo de piñon y cremallera
Valvula "back check" freno en la apertura
Velocidad de cierre ajustable por válvula
Velocidad de golpe final ajustable por válvula
Ángulo de apertura 180°
Cierra puertas reversible
Certificada corta fuego
Marcación CE



ML.21.770.BS

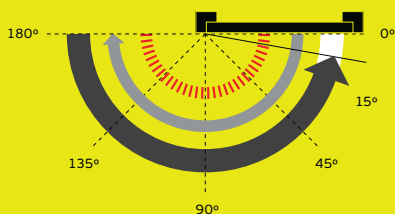

Abertura /
Opening /
Apertura.

Velocidade de fecho
Closing speed /
Velocidade de freno.

Velocidade do fecho final
Final closing speed /
Velocidade de golpe final.

Travagem na abertura /
Back-check /
Freno en la apertura.

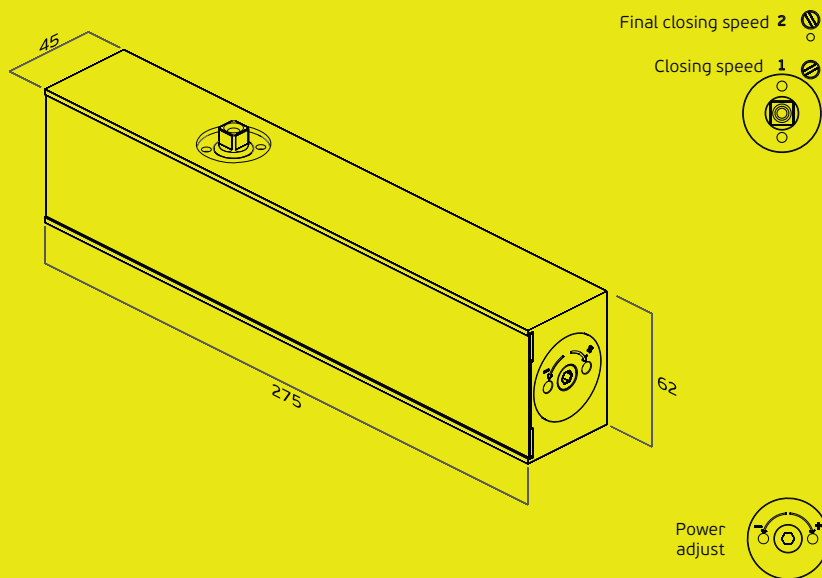

Final closing speed **2**

Closing speed **1**

Power adjust

1 Braço standard INOX /
Stainless steel standard arm /
Brazo estándar INOX.

2 Braço standard RAL 9006 /
RAL 9006 standard arm /
Brazo estándar RAL 9006.

3 Braço Anti-vandalismo /
sliding arm /
Brazo antivandalismo.

4 Braço Design INOX /
Stainless steel sliding arm /
Brazo diseño INOX.

A Tampa reforçada em aço inoxidável /
Reinforced stainless steel cover /
Cubierta reforzada en acero inoxidable /

B Tampa em aço inoxidável /
Stainless steel cover /
Cubierta en acero inoxidable /

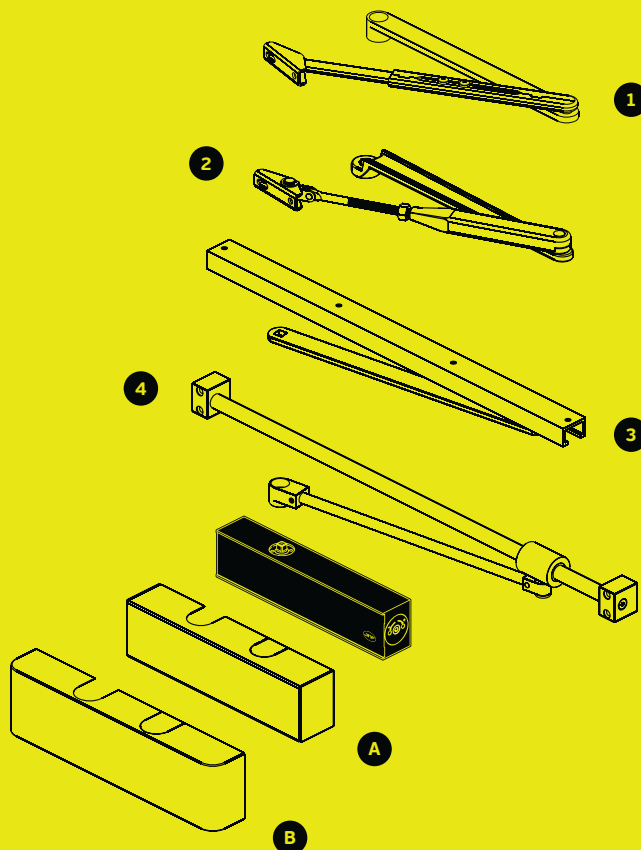

SÉRIE 765 - INOX

765 SERIES - INOX / SERIE 765 - INOX



EN1154

4	8	5	1	1	3
		2			



IN.21.765.BD

EN 1.4301 Satinado / Satin / Satin

Mola de porta aérea hidráulica de sobrepor
 Braço anti-vandalismo
 Força ajustável: 2-5
 Largura máxima de porta: 1250 mm
 Peso máximo de porta: 100 kg
 Ajuste de força por mola
 Mecanismo cremalheira e pinhão
 Velocidade de fecho ajustável por válvula
 Velocidade de fecho final ajustável por válvula
 Ângulo de abertura 180°
 Mola reversível
 Certificado Corta fogo
 Marcação CE

Hydraulic overhead door closer
 Sliding arm
 Adjustable Power: 2-5
 Maximum door width: 1250 mm
 Maximum door weight: 100 kg
 Power adjustment by spring
 Rack and pinion mechanism
 closing speed adjustable by valve
 Latching speed adjustable by valve
 Opening angle 180°
 Reversible door closer
 Certified Fire proof
 CE marking

Cierra puertas hidráulico de sobreponer
 Brazo antivandalismo
 Fuerza ajustable: 2-5
 Ancho máximo de puerta: 1250 mm
 Peso máximo de puerta: 100 kg
 Regulación de fuerza por muelle
 Mecanismo de piñon y cremallera
 Velocidad de cierre ajustable por válvula
 Velocidad de golpe final ajustable por válvula
 Ángulo de apertura 180°
 Cierra puertas reversible
 Certificada corta fuego
 Marcación CE





EN1154 48⁵2 1113



IN.21.765.BA

EN 1.4301 Satinado / Satin / Satin

Mola de porta aérea hidráulica de sobrepor
Braço anti-vandalismo
Força ajustável: 2-5
Largura máxima de porta: 1250 mm
Peso máximo de porta: 100 kg
Ajuste de força por mola
Mecanismo cremalheira e pinhão
Velocidade de fecho ajustável por válvula
Velocidade de fecho final ajustável por válvula
Sistema de retenção na abertura : amovível
Ângulo de abertura 180°
Mola reversível
Certificado Corta fogo
Marcação CE

Hydraulic overhead door closer
Sliding arm
Adjustable Power: 2-5
Maximum door width: 1250 mm
Maximum door weight: 100 kg
Power adjustment by spring
Rack and pinion mechanism
closing speed adjustable by valve
Latching speed adjustable by valve
Hold open system: revolvable
Opening angle 180°
Reversible door closer
Certified Fire proof
CE marking

Cierra puertas hidráulico de sobreponer
Brazo antivandalismo
Fuerza ajustable: 2-5
Ancho máximo de puerta: 1250 mm
Peso máximo de puerta: 100 kg
Regulación de fuerza por muelle
Mecanismo de piñon y cremallera
Velocidad de cierre ajustable por válvula
Velocidad de golpe final ajustable por válvula
Sistema de retención en la apertura: extraíble
Ángulo de apertura 180°
Cierra puertas reversible
Certificada corta fuego
Marcación CE



IN.21.765.BA.Q



ML.21.765.BA.R



ML.21.765.BA

SÉRIE 765 - INOX

765 SERIES - INOX / SERIE 765 - INOX



EN1154 4 8 ⁵/₂ 1 1 3



IN.21.765.BS

EN 1.4301 Satinado / Satin / Satin

Mola de porta aérea hidráulica de sobrepor
Braço standard sem paragem
Força ajustável: 2-5
Largura máxima de porta: 1250 mm
Peso máximo de porta: 100 kg
Ajuste de força por mola
Mecanismo cremalheira e pinhão
Velocidade de fecho ajustável por válvula
Velocidade de fecho final ajustável por válvula
Ângulo de abertura 180°
Mola reversível
Certificado Corta fogo
Marcação CE

Hydraulic overhead door closer
Standard arm without retaining
Adjustable Power: 2-5
Maximum door width: 1250 mm
Maximum door weight: 100 kg
Power adjustment by spring
Rack and pinion mechanism
closing speed adjustable by valve
Latching speed adjustable by valve
Opening angle 180°
Reversible door closer
Certified Fire proof
CE marking

Cierra puertas hidráulico de sobreponer
Brazo estandard sin retención
Fuerza ajustable: 2-5
Ancho máximo de puerta: 1250 mm
Peso máximo de puerta: 100 kg
Regulación de fuerza por muelle
Mecanismo de piñon y cremallera
Velocidad de cierre ajustable por válvula
Velocidad de golpe final ajustable por válvula
Ángulo de apertura 180°
Cierra puertas reversible
Certificada corta fuego
Marcación CE



IN.21.765.BS.Q



ML.21.765.BS.R



ML.21.765.BS

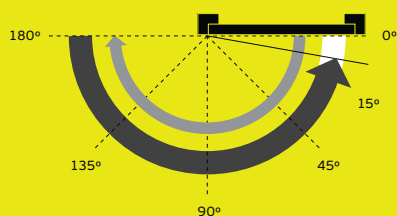

	Abertura / Opening / Apertura.
	Velocidade de fecho Closing speed / Velocidade de freno.
	Velocidade do fecho final Final closing speed / Velocidade de golpe final.

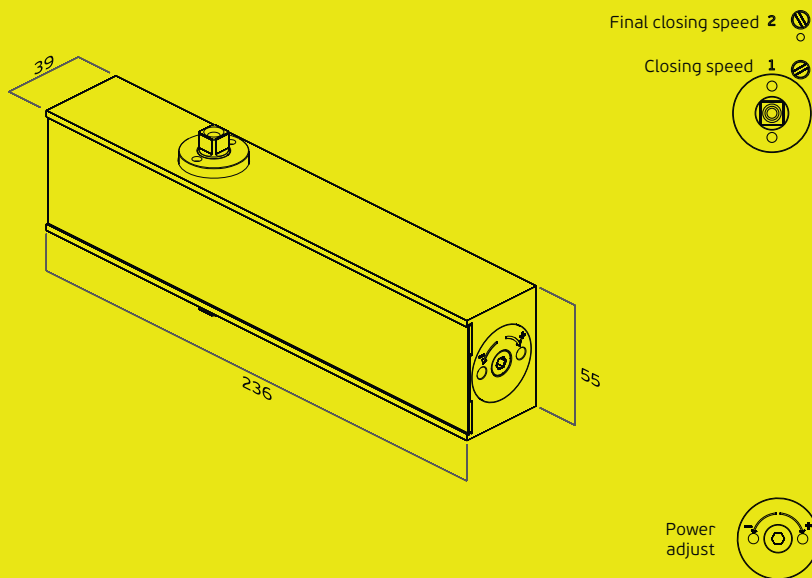

- | | |
|----------|--|
| 1 | Braço standard INOX /
Stainless steel standard arm /
Brazo estándar INOX. |
| 2 | Braço standard RAL 9006 /
RAL 9006 standard arm /
Brazo estándar RAL 9006. |
| 3 | Braço Anti-vandalismo /
sliding arm /
Brazo antivandalismo. |
| 4 | Braço Design INOX /
Stainless steel sliding arm /
Brazo diseño INOX. |
| A | Tampa reforçada em aço inoxidável /
Reinforced stainless steel cover /
Cubierta reforzada en acero inoxidable / |
| B | Tampa em aço inoxidável /
Stainless steel cover /
Cubierta en acero inoxidable / |
| C | Tampa em aço inoxidável /
Stainless steel cover /
Cubierta en acero inoxidable / |
| D | Tampa RAL 9006 /
RAL 9006 cover /
Cubierta RAL 9006 / |

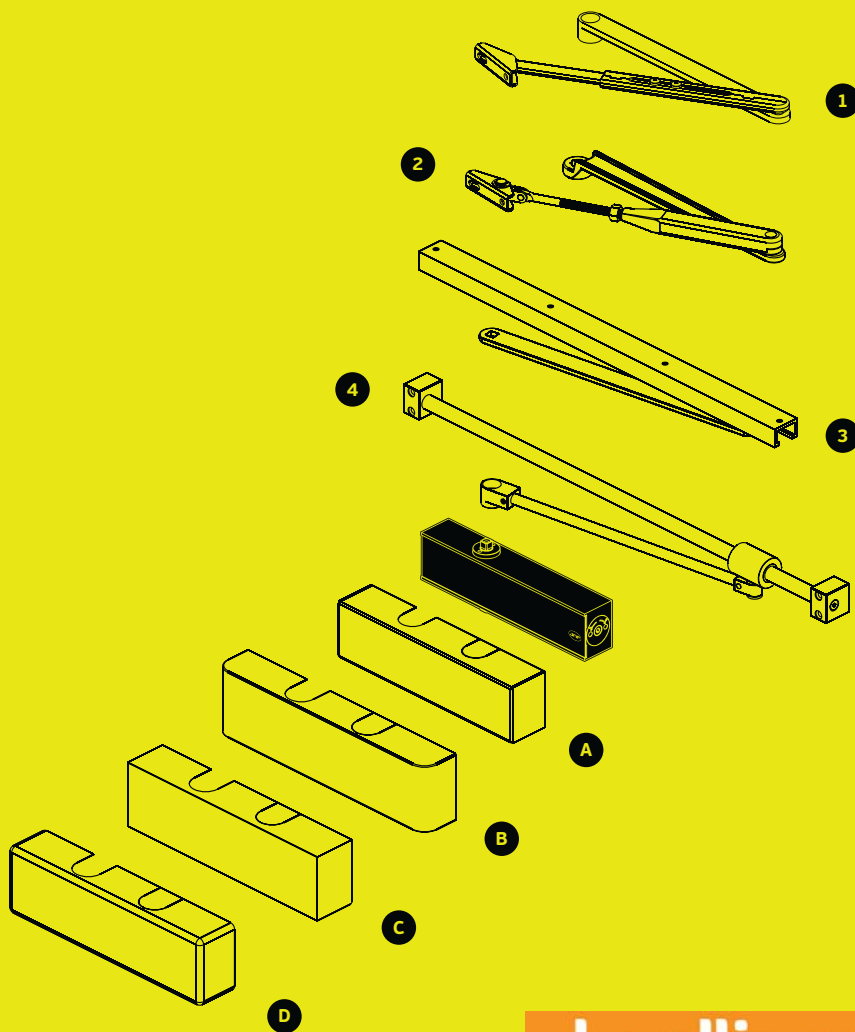

SÉRIE 760 - INOX

760 SERIES - INOX / SERIE 760 - INOX



EN1154 4|8|3|1|1|3



IN.21.760.BD

EN 1.4301 Satinado / Satin / Satin

Mola de porta aérea hidráulica de sobrepor
Braço anti-vandalismo

Força: 3

Largura máxima de porta: 950 mm

Peso máximo de porta: 60 kg

Mecanismo cremalheira e pinhão

Velocidade de fecho ajustável por válvula

Velocidade de fecho final ajustável por válvula

Ângulo de abertura 180°

Mola reversível

Certificado Corta fogo

Marcação CE

Hydraulic overhead door closer
Sliding Arm

Power: 3

Maximum door width: 950 mm

Maximum door weight: 60 kg

Rack and pinion mechanism

closing speed adjustable by valve

Latching speed adjustable by valve

Opening angle 180°

Reversible door closer

Certified Fire proof

CE marking

Cierra puertas hidráulico de sobreponer
Braço antivandalismo

Fuerza: 3

Ancho máximo de puerta: 950 mm

Peso máximo de puerta: 60 kg

Mecanismo de piñon y cremallera

Velocidad de cierre ajustable por válvula

Velocidad de golpe final ajustable por válvula

Ángulo de apertura 180°

Cierra puertas reversible

Certificada corta fuego

Marcación CE





EN1154 4|8|3|1|1|3



IN.21.760.BA

EN 1.4301 Satinado / Satin / Satin

Mola de porta aérea hidráulica de sobrepor
Braço anti-vandalismo
Força : 3

Largura máxima de porta: 950 mm

Peso máximo de porta: 60 kg

Mecanismo cremalheira e pinhão

Velocidade de fecho ajustável por válvula

Velocidade de fecho final ajustável por válvula

Sistema de retenção na abertura : amovível

Ângulo de abertura 180°

Mola reversível

Certificado Corta fogo

Marcação CE

Hydraulic overhead door closer
Sliding Arm

Power: 3

Maximum door width: 950 mm

Maximum door weight: 60 kg

Rack and pinion mechanism

closing speed adjustable by valve

Latching speed adjustable by valve

Hold open system: revolvable

Opening angle 180°

Reversible door closer

Certified Fire proof

CE marking

Cierra puertas hidráulico de sobreponer
Brazo antivandalismo

Fuerza: 3

Ancho máximo de puerta: 950 mm

Peso máximo de puerta: 60 kg

Mecanismo de piñon y cremallera

Velocidad de cierre ajustable por válvula

Velocidad de golpe final ajustable por válvula

Sistema de retención en la apertura: extraíble

Ángulo de apertura 180°

Cierra puertas reversible

Certificada corta fuego

Marcación CE



IN.21.760.BA.Q



ML.21.760.BA.R



ML.21.760.BA

SÉRIE 760 - INOX

760 SERIES - INOX / SERIE 760 - INOX



EN1154 48 2 1113



IN.21.760.BS

EN 1.4301 Satinado / Satin / Satin

Mola de porta aérea hidráulica de sobrepor
Braço standard sem paragem
Força ajustável: 2-4
Largura máxima de porta: 1100 mm
Peso máximo de porta: 80 kg
Ajuste de força por posição
Mecanismo cremalheira e pinhão
Velocidade de fecho ajustável por válvula
Velocidade de fecho final ajustável por válvula
Ângulo de abertura 180°
Mola reversível
Certificado Corta fogo
Marcação CE

Hydraulic overhead door closer
Standard arm without retaining
Adjustable Power: 2-4
Maximum door width: 1100 mm
Maximum door weight: 80 kg
Power adjustment by position
Rack and pinion mechanism
closing speed adjustable by valve
Latching speed adjustable by valve
Opening angle 180°
Reversible door closer
Certified Fire proof
CE marking

Cierra puertas hidráulico de sobreponer
Brazo estandard sin retención
Fuerza ajustable: 2-4
Ancho máximo de puerta: 1100 mm
Peso máximo de puerta: 80 kg
Regulación de fuerza por posición
Mecanismo de piñon y cremallera
Velocidad de cierre ajustable por válvula
Velocidad de golpe final ajustable por válvula
Ángulo de apertura 180°
Cierra puertas reversible
Certificada corta fuego
Marcación CE



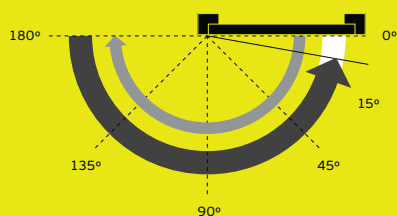

	Abertura / Opening / Apertura.
	Velocidade de fecho Closing speed / Velocidade de freno.
	Velocidade do fecho final Final closing speed / Velocidade de golpe final.

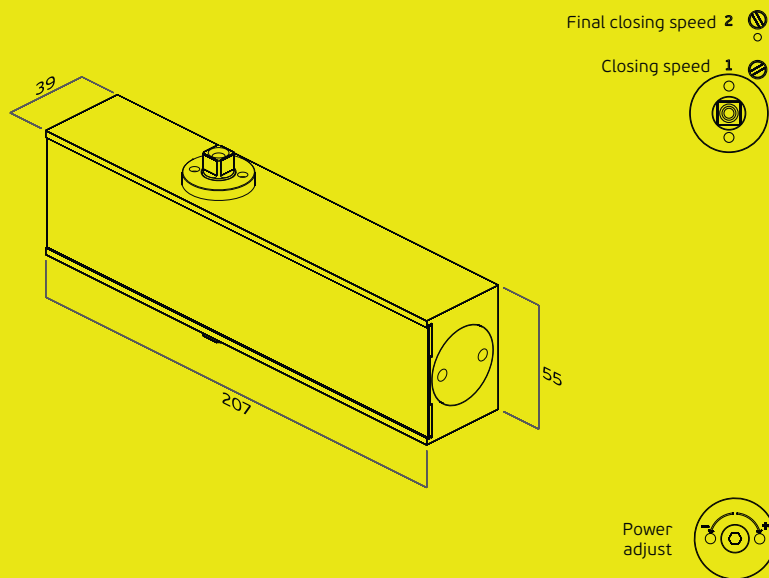

- | | |
|----------|--|
| 1 | Braço standard INOX /
Stainless steel standard arm /
Brazo estándar INOX. |
| 2 | Braço standard RAL 9006 /
RAL 9006 standard arm /
Brazo estándar RAL 9006. |
| 3 | Braço Anti-vandalismo /
sliding arm /
Brazo antivandalismo. |
| 4 | Braço Design INOX /
Stainless steel sliding arm /
Brazo diseño INOX. |
| A | Tampa reforçada em aço inoxidável /
Reinforced stainless steel cover /
Cubierta reforzada en acero inoxidable / |
| B | Tampa em aço inoxidável /
Stainless steel cover /
Cubierta en acero inoxidable / |
| C | Tampa em aço inoxidável /
Stainless steel cover /
Cubierta en acero inoxidable / |
| D | Tampa RAL 9006 /
RAL 9006 cover /
Cubierta RAL 9006 / |

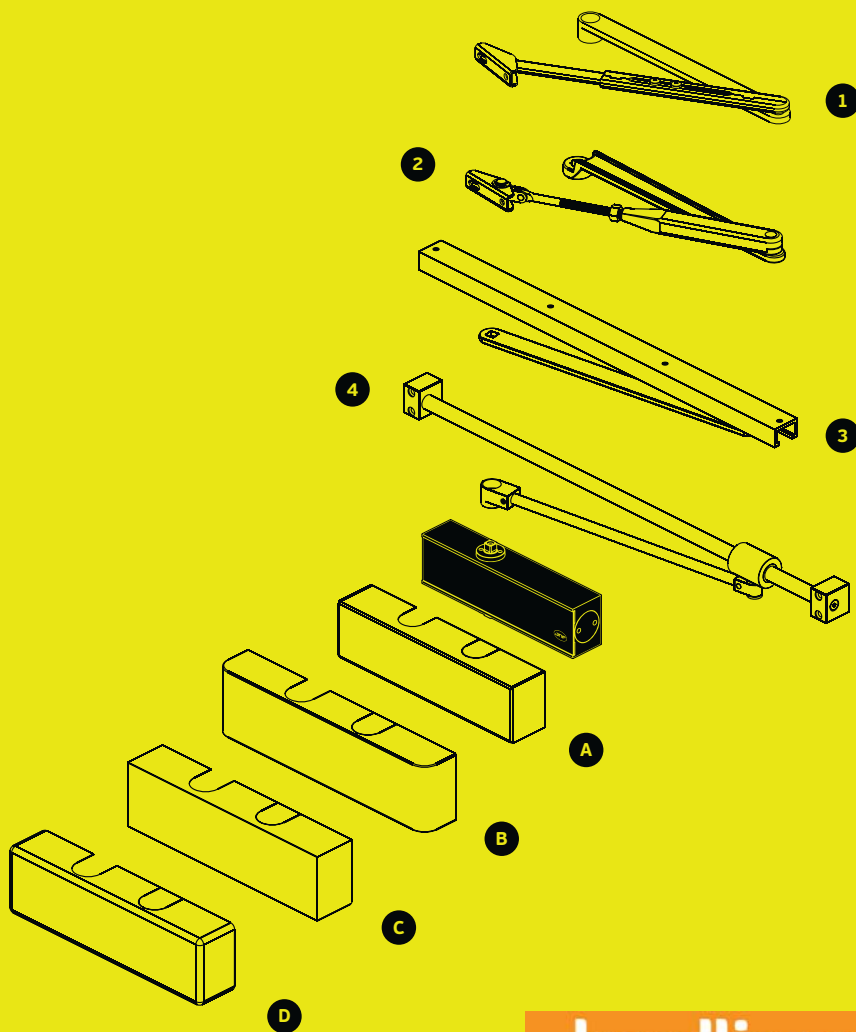

SÉRIE 600 /

600 SERIES /

SERIE 600.



EN1154

4	8	2	1	1	3
		5			



ML.21.610

Mola de porta aérea hidráulica de sobrepor
 Braço standard sem paragem
 Força ajustável: 2-5
 Largura máxima de porta: 1250 mm
 Peso máximo de porta: 100 kg
 Ajuste de força por mola
 Mecanismo cremalheira e pinhão
 Velocidade de fecho ajustável por válvula
 Velocidade de fecho final ajustável por válvula
 Ângulo de abertura 180°
 Mola reversível
 Certificado Corta fogo
 Marcação CE

Hydraulic overhead door closer
 Standard arm without retaining
 Adjustable Power: 2-5
 Maximum door width: 1250 mm
 Maximum door weight: 100 kg
 Power adjustment by spring
 Rack and pinion mechanism
 closing speed adjustable by valve
 Lathing speed adjustable by valve
 Opening angle 180°
 Reversible door closer
 Certified Fire proof
 CE marking

Cierra puertas hidráulico de sobreponer
 Brazo estandard sin retención
 Fuerza ajustable: 2-5
 Ancho máximo de puerta: 1250 mm
 Peso máximo de puerta: 100 kg
 Regulación de fuerza por muelle
 Mecanismo de piñon y cremallera
 Velocidad de cierre ajustable por válvula
 Velocidad de golpe final ajustable por válvula
 Ángulo de apertura 180°
 Cierra puertas reversible
 Certificada corta fuego
 Marcación CE

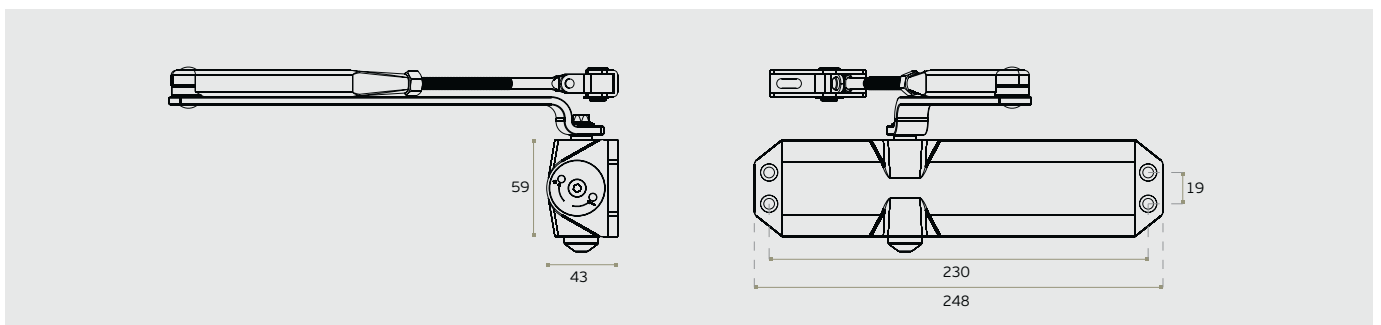



EN1154

4	8	2
4	1	1
	3	



ML.21.600

Mola de porta aérea hidráulica de sobrepor
Braço standard sem paragem
Força ajustável: 2-4
Largura máxima de porta: 1100 mm
Peso máximo de porta: 80 kg
Ajuste de força por posição
Mecanismo cremalheira e pinhão
Velocidade de fecho ajustável por válvula
Velocidade de fecho final ajustável por válvula
Ângulo de abertura 180°
Mola reversível
Certificado Corta fogo

Hydraulic overhead door closer
Standard arm without retaining
Adjustable Power: 2-4
Maximum door width: 1100 mm
Maximum door weight: 80 kg
Power adjustment by position
Rack and pinion mechanism
closing speed adjustable by valve
Latching speed adjustable by valve
Opening angle 180 °
Reversible door closer
Certified Fire proof

Cierra puertas hidráulico de sobreponer
Brazo estandard sin retención
Fuerza ajustable: 2-4
Ancho máximo de puerta: 1100 mm
Peso máximo de puerta: 80 kg
Regulación de fuerza por posición
Mecanismo de piñon y cremallera
Velocidad de cierre ajustable por válvula
Velocidad de golpe final ajustable por válvula
Ángulo de apertura 180 °
Cierra puertas reversible
Certificada corta fuego

21.205

RAL 9006

Cobertura para mola /

Cover for door closer / Cobertura para cierra
puertas

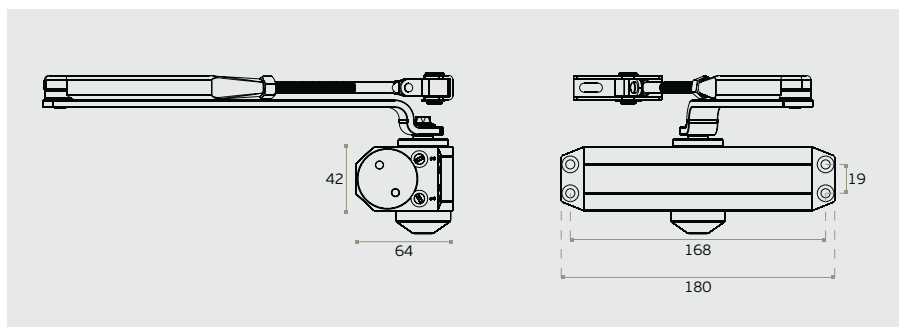

FREELINE



FREELINE

ML.21.550

Mola de porta aérea hidráulica de sobrepor
 Braço standard sem paragem
 Força fixa: 3
 Largura máxima de porta: 1000 mm
 Peso máximo de porta: 60 kg
 Mecanismo cremalheira e pinhão
 Velocidade de fecho ajustável por válvula
 Velocidade de fecho final ajustável por válvula
 Ângulo de abertura 180°
 Mola reversível

Hydraulic overhead door closer
 Standard arm without retaining
 Fixed Power: 3
 Maximum door width: 1000 mm
 Maximum door weight: 60 kg
 Rack and pinion mechanism
 closing speed adjustable by valve
 Latching speed adjustable by valve
 Opening angle 180 °
 Reversible door closer

Cierra puertas hidráulico de sobreponer
 Brazo estándar sin retención
 Fuerza fija: 3
 Ancho máximo de puerta: 1000 mm
 Peso máximo de puerta: 60 kg
 Mecanismo de piñon y cremallera
 Velocidad de cierre ajustable por válvula
 Velocidad de golpe final ajustable por válvula
 Ángulo de apertura 180 °
 Cierra puertas reversible

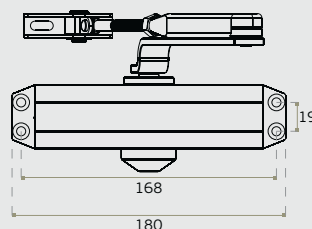
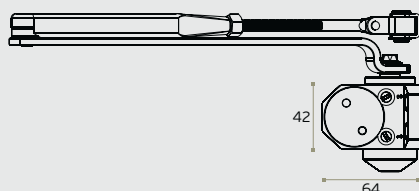

MOLAS DE PORTA DE EMBUTIR / CONCEALED DOOR CLOSERS / CIERRA PUERTAS DE EMBUTIR

As molas de porta ocultas JNF são uma solução inovadora para os edifícios modernos, permitindo uma integração perfeita do mecanismo no interior da porta.

O mecanismo fica completamente oculto na porta graças ao corpo compacto não comprometendo a performance.

Dispomos de uma vasta gama de soluções que permitem a instalação em quase todas as situações:

- Portas com espessura desde 35mm;
- Molas para pessoas com mobilidade condicionada (DDA);
- Portas corta fogo;
- Portas vai-vém

JNF concealed door closers is the ultimate solution for modern buildings that allows a perfect integration of the mechanism inside the door.

No visible mechanisms due to the very compact and slim body but very at same time performant.

We have a big assortment of solutions that allows the installation in almost situations:

- Door thickness from 35mm;
- Door closers for disable people (DDA);
- Fire proof doors;
- Double action doors.

Los cierra puertas ocultos JNF son una solución innovadora para los edificios modernos, lo que permite una integración perfecta del mecanismo dentro de la puerta.

El mecanismo está completamente oculto por la puerta gracias al cuerpo compacto y no comprometa el rendimiento.

Tenemos una amplia gama de soluciones que permiten su instalación en casi todos situaciones:

- Puertas con espesor desde 35 mm;
- Cierra puertas para personas con movilidad condicionada (DDA);
- Puertas cortafuego;
- Puertas de doble acción.



MOLAS DE PORTA DE EMBUTIR / CONCEALED DOOR CLOSERS / CIERRA PUERTAS DE EMBUTIR



EN1154

3	8	2	1	1	3
		4			



ML.21.813

Mola de porta aérea hidráulica de embutir para portas de batente.
Braço anti-vandalismo
Força ajustável: 2-4
Largura máxima de porta: 1100 mm
Peso máximo de porta: 130 kg
Ajuste de força por mola
Mecanismo CAM
Velocidade de fecho ajustável por válvula
Velocidade de fecho final ajustável por válvula
Sistema de retenção na abertura : amovível
Ângulo de abertura 120°
Mola reversível
Certificado Corta fogo
Marcação CE

Concealed hydraulic overhead door closer to single action.
Sliding Arm
Adjustable Power: 2-4
Maximum door width: 1100 mm
Maximum door weight: 130 kg
Power adjustment by spring
CAM action mechanism
closing speed adjustable by valve
Latching speed adjustable by valve
Hold open system: revolvable
Opening angle 120°
Reversible door closer
Certified Fire proof
CE marking

Cierra puertas hidráulico de embutir para puertas de batiente.
Brazo antivandalismo
Fuerza ajustable: 2-4
Ancho máximo de puerta: 1100 mm
Peso máximo de puerta: 130 kg
Regulación de fuerza por muelle
Mecanismo de CAM
Velocidad de cierre ajustable por válvula
Velocidad de golpe final ajustable por válvula
Sistema de retención en la apertura: extraíble
Ángulo de apertura 120°
Cierra puertas reversible
Certificada corta fuego
Marcación CE

KI.812

Kit intumescente para mola de porta IN.21.813/
Intumescent kit for door closer IN.21.813/
Kit intumescente para cierra puertas IN.21.813

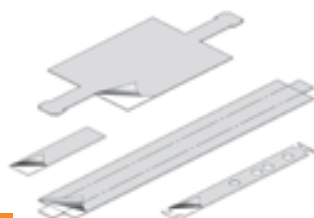

21.812.PL

Terminal em plástico para a calha IN.21.813/
Plastic terminal for track IN.21.813/
Terminal en plástico para calha IN.21.813



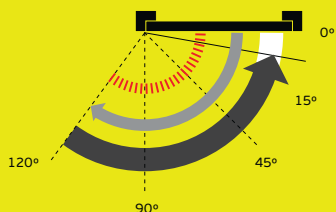

- Abertura /**
Opening /
Apertura.

- Velocidade de fecho**
Closing speed /
Velocidade de freno.

- Velocidade do fecho final**
Final closing speed /
Velocidade de golpe final.

- Retenção na abertura : amovível /**
Hold open system: revovable
retención en la apertura: extraíble.

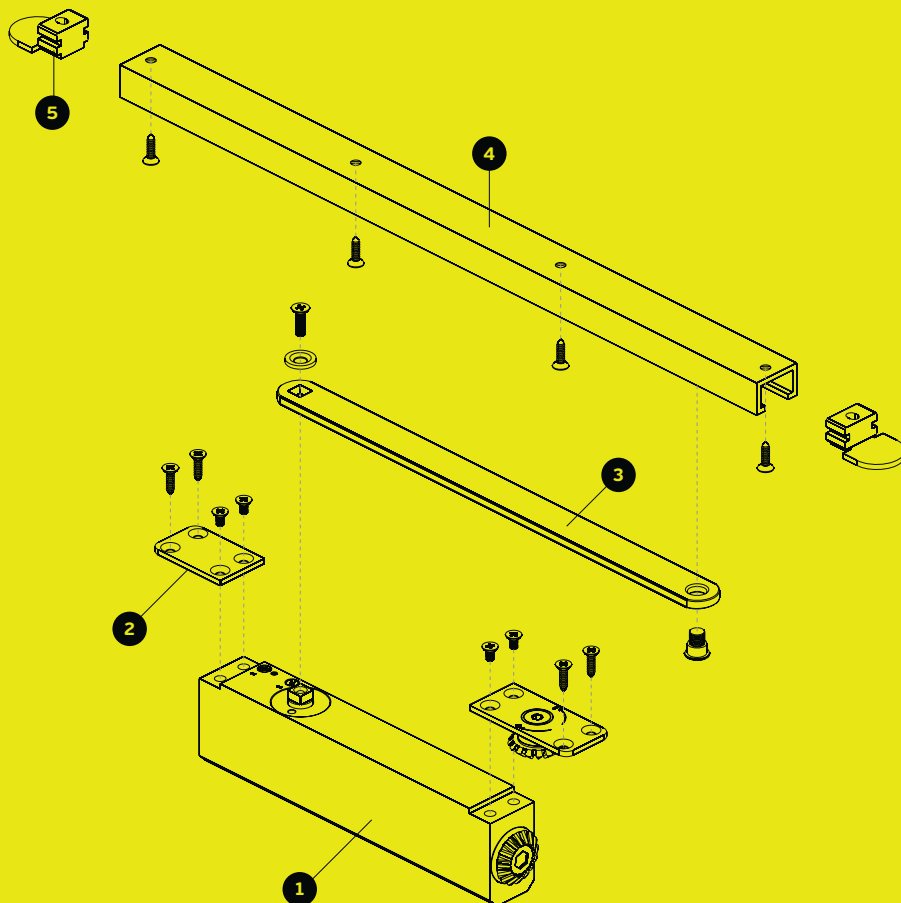
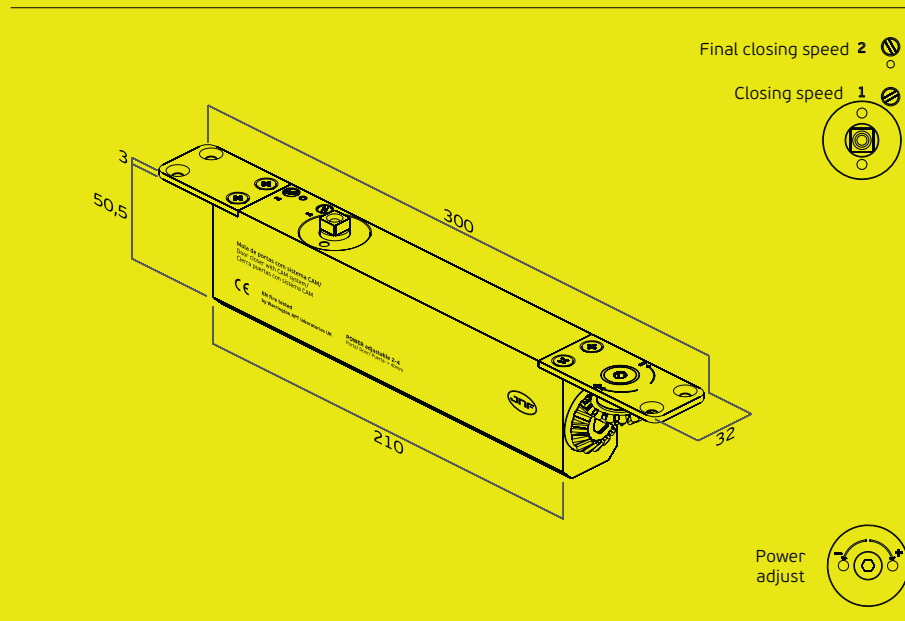

- 1** **Corpo /**
Body /
Cuerpo /

- 2** **Barra de fixação /**
Fixing plate /
Barra de sujeción /

- 3** **Braço /**
Stainless steel cover /
Cubierta en acero inoxidable /

- 4** **Calha /**
Track /
Cubierta RAL 9006 /

- 5** **Terminal /**
Terminal /
Terminal /

MOLAS DE PORTA DE EMBUTIR / CONCEALED DOOR CLOSERS / CIERRA PUERTAS DE EMBUTIR



EN1154 3 8 2 1 1 3 4

DOUBLE ACTION



ML.21.812

Mola de porta aérea hidráulica de embutir para portas de dupla acção.

Braço anti-vandalismo

Força ajustável: 2-4

Largura máxima de porta: 1100 mm

Peso máximo de porta: 130 kg

Ajuste de força por mola

Mecanismo CAM

Velocidade de fecho ajustável por válvula

Velocidade de fecho final ajustável por válvula

Sistema de retenção na abertura : amovível

Ângulo de abertura 240°

Mola reversível

Certificado Corta fogo

Marcação CE

Concealed hydraulic overhead door closer for double action.

Sliding Arm

Adjustable Power: 2-4

Maximum door width: 1100 mm

Maximum door weight: 130 kg

Power adjustment by spring

CAM action mechanism

closing speed adjustable by valve

Lathing speed adjustable by valve

Hold open system: revolvable

Opening angle 240°

Reversible door closer

Certified Fire proof

CE marking

Cierra puertas hidráulico de embutir para puertas de doble acción.

Brazo antivandalismo

Fuerza ajustable: 2-4

Ancho máximo de puerta: 1100 mm

Peso máximo de puerta: 130 kg

Regulación de fuerza por muelle

Mecanismo de CAM

Velocidad de cierre ajustable por válvula

Velocidad de golpe final ajustable por válvula

Sistema de retención en la apertura: extraíble

Ángulo de apertura 240°

Cierra puertas reversible

Certificada corta fuego

Marcación CE

KI.812

Kit intumescente para mola

de porta IN.21.812/

Intumescent kit for door

closer IN.21.812/

Kit intumescente para cierra

puertas IN.21.812

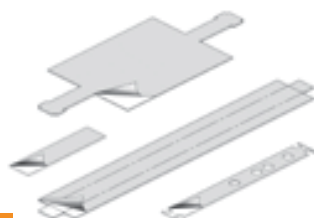

21.812.PL

Terminal em plástico

para a calha IN.21.812/

Plastic terminal for

track IN.21.812/

Terminal en plástico

para calha IN.21.812



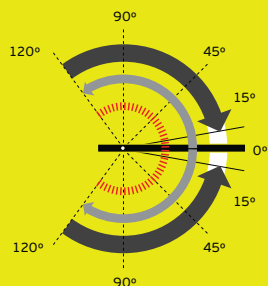

- Abertura /**
Opening /
Apertura.

- Velocidade de fecho**
Closing speed /
Velocidade de freno.

- Velocidade do fecho final**
Final closing speed /
Velocidade de golpe final.

- Retenção na abertura : amovível /**
Hold open system: revolvable /
retención en la apertura: extraíble.

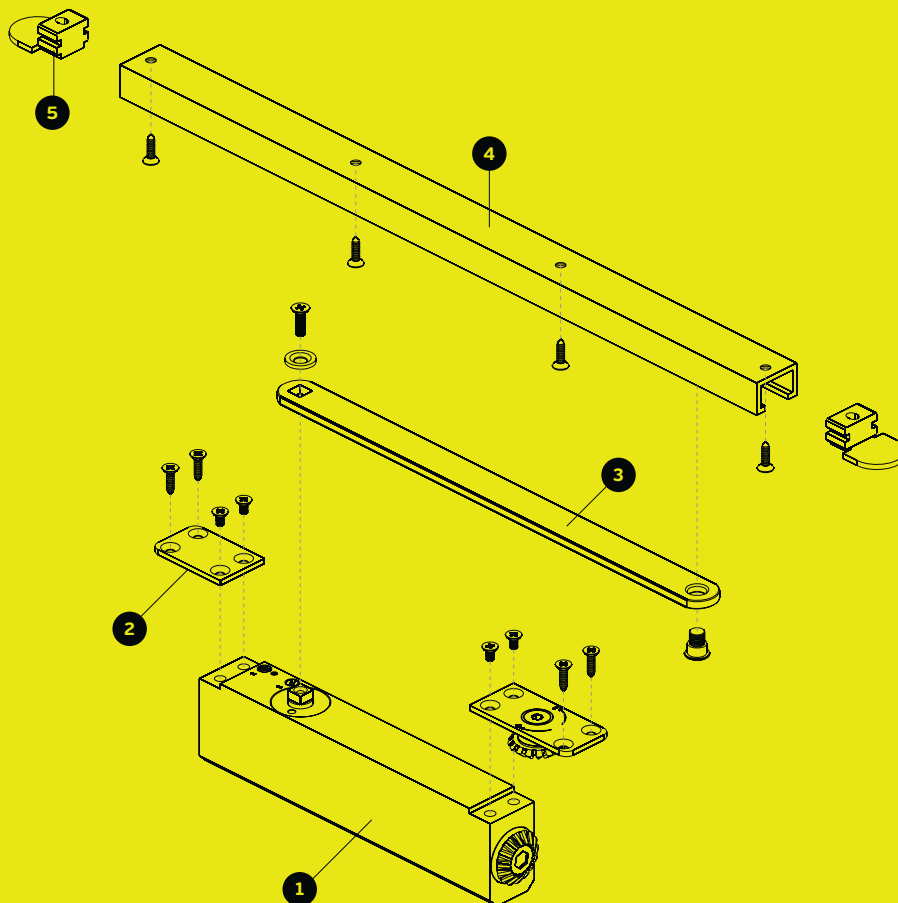
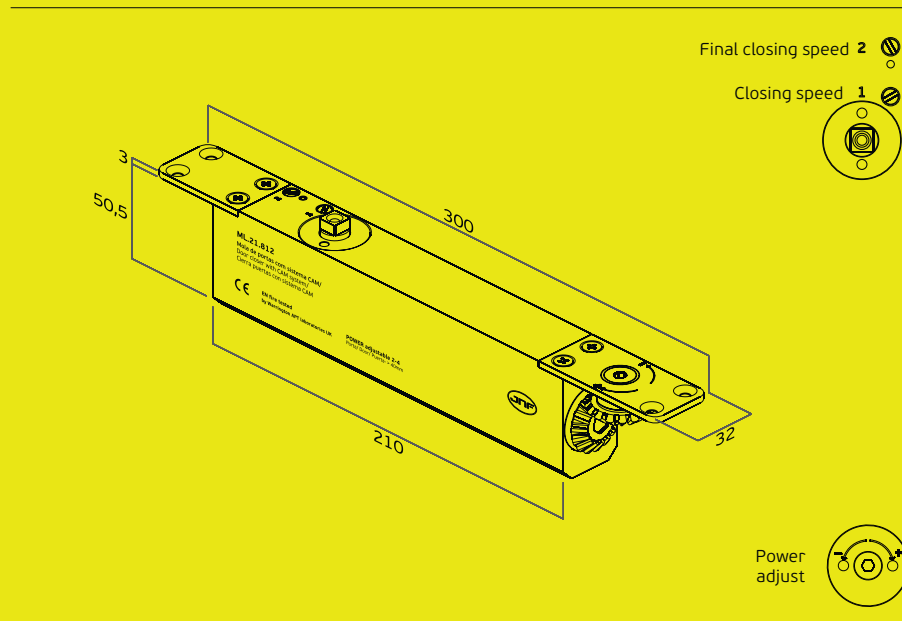

- 1** **Corpo /**
Body /
Cuerpo /

- 2** **Barra de fixação /**
Fixing plate /
Barra de sujeción /

- 3** **Braço /**
Stainless steel cover /
Cubierta en acero inoxidable /

- 4** **Calha /**
Track /
Cubierta RAL 9006 /

- 5** **Terminal /**
Terminal /
Terminal /

MOLAS DE PORTA DE EMBUTIR / CONCEALED DOOR CLOSERS / CIERRA PUERTAS DE EMBUTIR



EN1154

3	8	2	1	1	3
		4			



ML.21.810

Mola de porta aérea hidráulica de embutir para portas de batente.

Braço anti-vandalismo

Força ajustável: 2-4

Largura máxima de porta: 1100 mm

Peso máximo de porta: 130 kg

Ajuste de força por mola

Mecanismo cremalheira e pinhão

Velocidade de fecho ajustável por válvula

Velocidade de fecho final ajustável por válvula

Sistema de retenção na abertura: amovível

Ângulo de abertura 120°

Mola reversível

Certificado Corta fogo

Concealed hydraulic overhead door closer to single action.

Sliding Arm

Adjustable Power: 2-4

Maximum door width: 1100 mm

Maximum door weight: 130 kg

Power adjustment by spring

Rack and pinion mechanism

closing speed adjustable by valve

Latching speed adjustable by valve

Hold open system: revolvable

Opening angle 120°

Reversible door closer

Certified Fire proof

Cierra puertas hidráulico de embutir para puertas de batiente.

Braço antivandalismo

Fuerza ajustable: 2-4

Ancho máximo de puerta: 1100 mm

Peso máximo de puerta: 130 kg

Regulación de fuerza por muelle

Mecanismo de piñon y cremallera

Velocidad de cierre ajustable por válvula

Velocidad de golpe final ajustable por válvula

Sistema de retención en la apertura: extraíble

Ángulo de apertura 120°

Cierra puertas reversible

Certificada corta fuego

KI.810

Kit intumescente para mola

de porta IN.21.810/

Intumescent kit for door

closer IN.21.810/

Kit intumescente para cierra

puertas IN.21.810

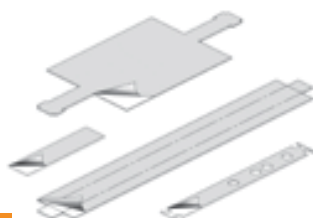

21.812.PL

Terminal em plástico

para a calha IN.21.810/

Plastic terminal for

track IN.21.810/

Terminal en plástico

para calha IN.21.810



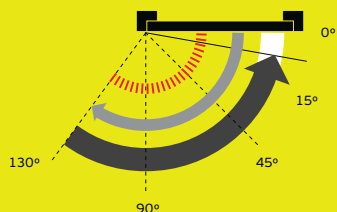

- Abertura /**
Opening /
Apertura.

- Velocidade de fecho**
Closing speed /
Velocidade de freno.

- Velocidade do fecho final**
Final closing speed /
Velocidade de golpe final.

- Retenção na abertura : amovível /**
Hold open system: revovable
retención en la apertura: extraíble.

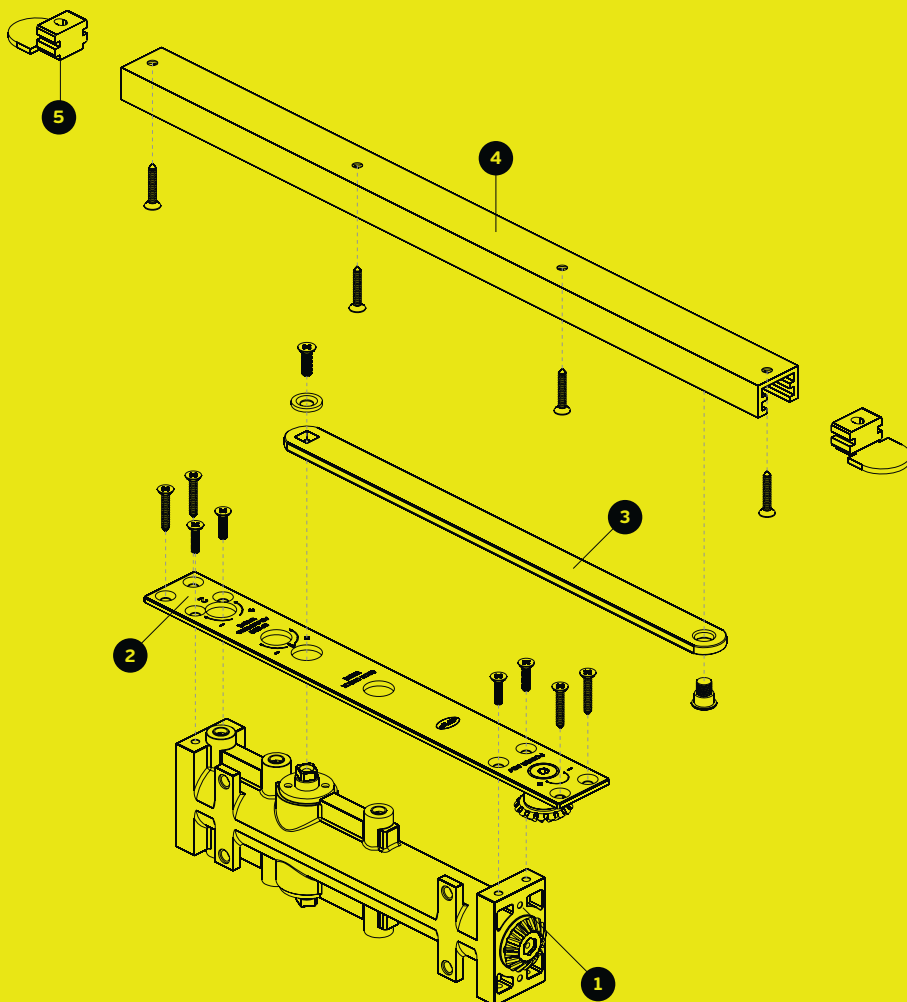
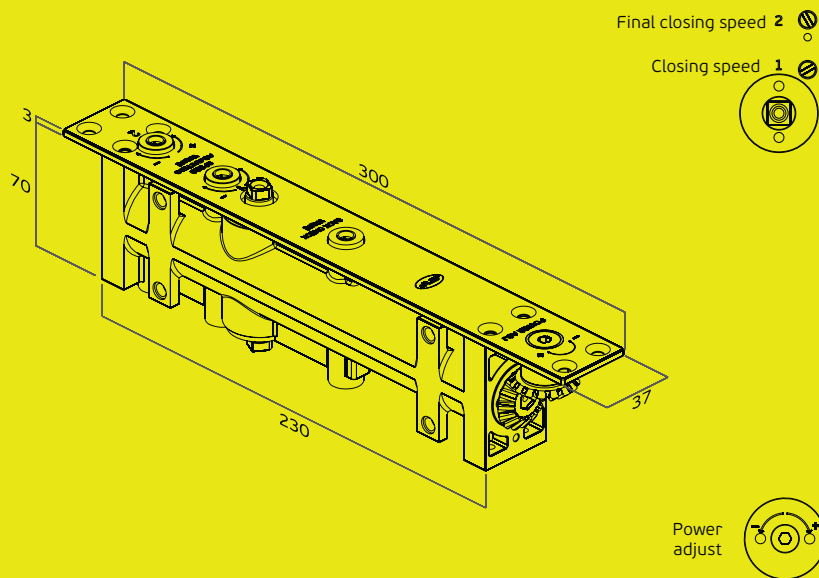

- 1** **Corpo /**
Body /
Cuerpo /

- 2** **Barra de fixação /**
Fixing plate /
Barra de sujeción /

- 3** **Braço /**
Stainless steel cover /
Cubierta en acero inoxidable /

- 4** **Calha /**
Track /
Cubierta RAL 9006 /

- 5** **Terminal /**
Terminal /
Terminal /

MOLAS DE PORTA DE EMBUTIR / CONCEALED DOOR CLOSERS / CIERRA PUERTAS DE EMBUTIR



EN1154 3|8|3|-|1|3



ML.21.802

Mola de porta aérea hidráulica de embutir para portas de batente.

Braço anti-vandalismo

Força: 3

Largura máxima de porta: 950 mm

Espessura mínima de porta: 35mm

Peso máximo de porta: 60 kg

Mecanismo cremalheira e pinhão

Velocidade de fecho ajustável por válvula

Velocidade de fecho final ajustável por válvula

Sistema de retenção na abertura : amovível

Ângulo de abertura 120°

Mola reversível

Certificado Corta fogo

Concealed hydraulic overhead door closer to single action.

Sliding Arm

Power: 3

Maximum door width: 950 mm

Minimum door thickness: 35mm

Maximum door weight: 60 kg

Rack and pinion mechanism

closing speed adjustable by valve

Latching speed adjustable by valve

Hold open system: revolvable

Opening angle 120°

Reversible door closer

Certified Fire proof

Cierra puertas hidráulico de embutir para puertas de batiente.

Brazo antivandalismo

Fuerza: 3

Ancho máximo de puerta: 950 mm

Espesor mínimo de la puerta: 35mm

Peso máximo de puerta: 60 kg

Mecanismo de piñon y cremallera

Velocidad de cierre ajustable por válvula

Velocidad de golpe final ajustable por válvula

Sistema de retención en la apertura: extraíble

Ángulo de apertura 120°

Cierra puertas reversible

Certificada corta fuego

KI.802

Kit intumescente para mola

de porta IN.21.802/

Intumescent kit for door

closer IN.21.802/

Kit intumescente para cierra

puertas IN.21.802

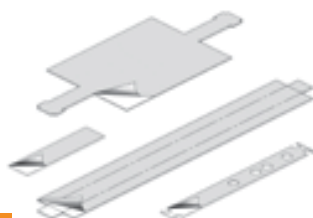

21.802.PL

Terminal em plástico

para a calha IN.21.802/

Plastic terminal for

track IN.21.802/

Terminal en plástico

para calha IN.21.802



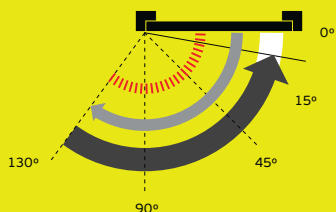

- Abertura /**
Opening /
Apertura.

- Velocidade de fecho**
Closing speed /
Velocidade de freno.

- Velocidade do fecho final**
Final closing speed /
Velocidade de golpe final.

- Retenção na abertura : amovível /**
Hold open system: revolvable /
retención en la apertura: extraíble.

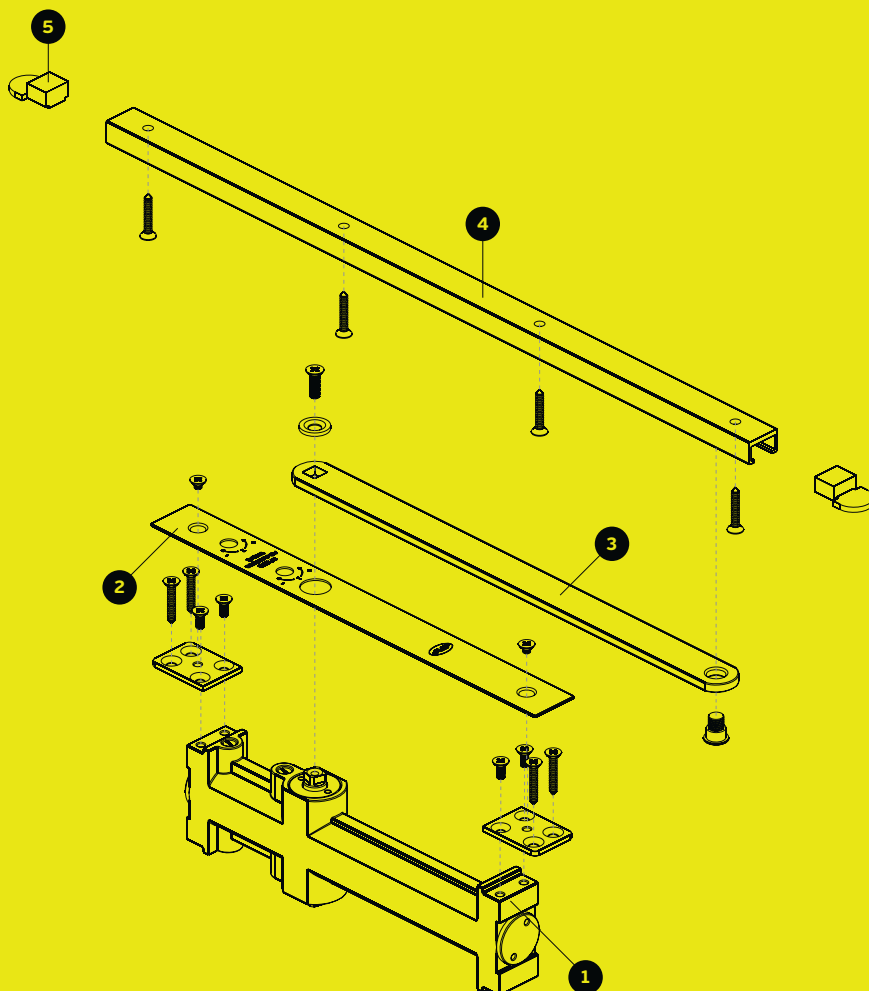
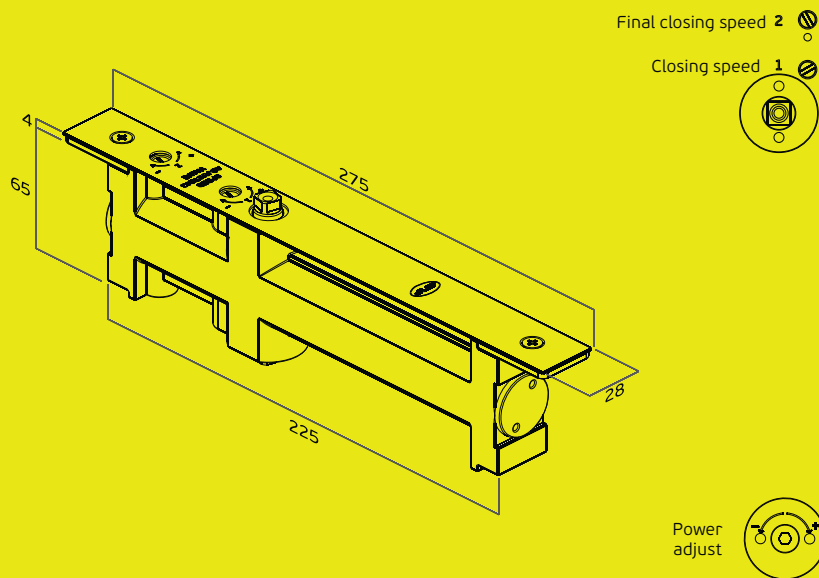

- 1** **Corpo /**
Body /
Cuerpo /

- 2** **Barra de fixação /**
Fixing plate /
Barra de sujeción /

- 3** **Braço /**
Stainless steel cover /
Cubierta en acero inoxidable /

- 4** **Calha /**
Track /
Cubierta RAL 9006 /

- 5** **Terminal - Opcional 21.802.PL /**
End cover - Optional - 21.802.PL /
Terminal /

MOLAS DE PORTA DE EMBUTIR / CONCEALED DOOR CLOSERS / CIERRA PUERTAS DE EMBUTIR



EN1154 3|8|3|1|1|3



ML.21.801

Mola de porta aérea hidráulica de embutir para portas de batente.
 Braço anti-vandalismo
 Força: 3
 Largura máxima de porta: 950 mm
 Peso máximo de porta: 100 kg
 Mecanismo cremalheira e pinhão
 Velocidade de fecho ajustável por válvula
 Velocidade de fecho final ajustável por válvula
 Sistema de retenção na abertura: amovível
 Ângulo de abertura 120°
 Mola reversível
 Certificado Corta fogo

Concealed hydraulic overhead door closer to single action.
 Sliding Arm
 Power: 3
 Maximum door width: 950 mm
 Maximum door weight: 100 kg
 Rack and pinion mechanism
 closing speed adjustable by valve
 Lathing speed adjustable by valve
 Hold open system: revolvable
 Opening angle 120°
 Reversible door closer
 Certified Fire proof

Cierra puertas hidráulico de embutir para puertas de batiente.
 Brazo antivandalismo
 Fuerza: 3
 Ancho máximo de puerta: 950 mm
 Peso máximo de puerta: 100 kg
 Mecanismo de piñon y cremallera
 Velocidad de cierre ajustable por válvula
 Velocidad de golpe final ajustable por válvula
 Sistema de retención en la apertura: extraíble
 Ángulo de apertura 120°
 Cierra puertas reversible
 Certificada corta fuego

KI.801

Kit intumescente para mola de porta IN.21.801/
 Intumescent kit for door closer IN.21.801/
 Kit intumescente para cierra puertas IN.21.801

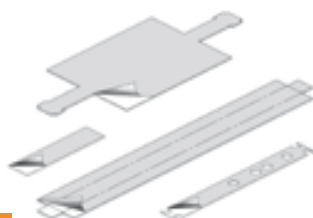

21.812.PL

Terminal em plástico para a calha IN.21.801/
 Plastic terminal for track IN.21.801/
 Terminal en plástico para calha IN.21.801



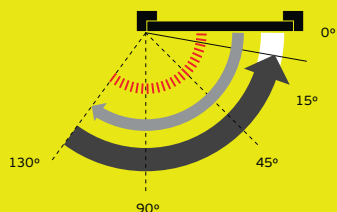

- Abertura /**
Opening /
Apertura.

- Velocidade de fecho**
Closing speed /
Velocidade de freno.

- Velocidade do fecho final**
Final closing speed /
Velocidade de golpe final.

- Retenção na abertura : amovível /**
Hold open system: revolvable /
retención en la apertura: extraíble.

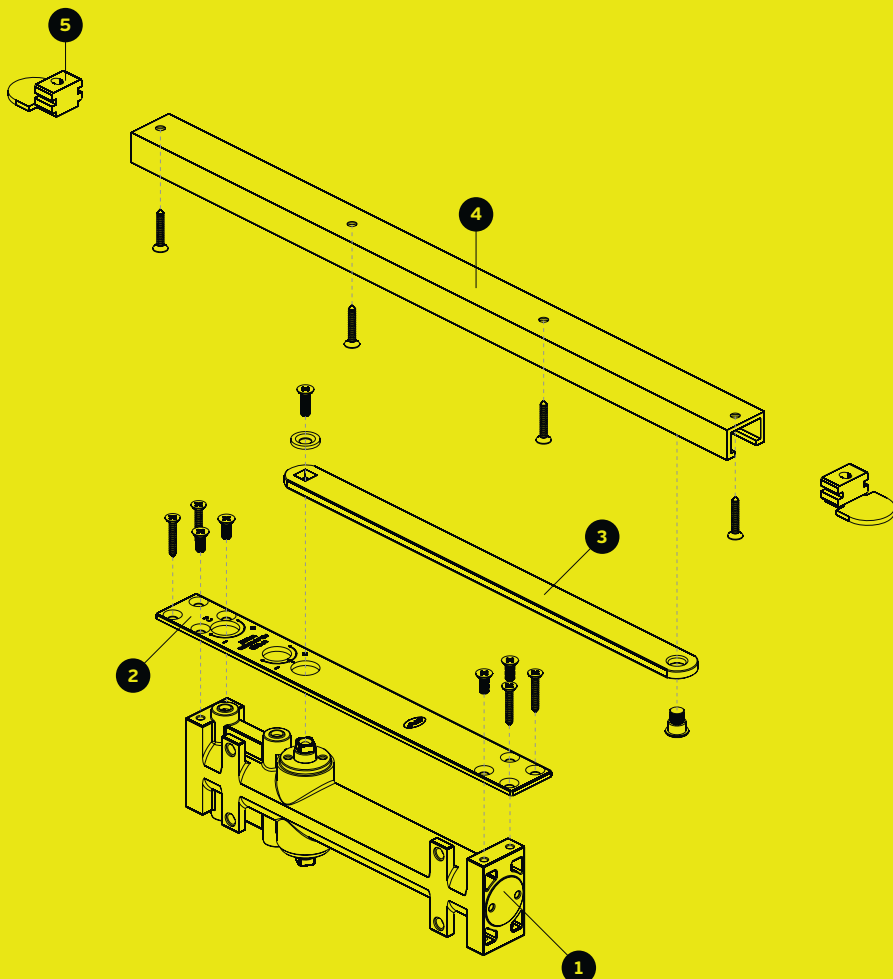
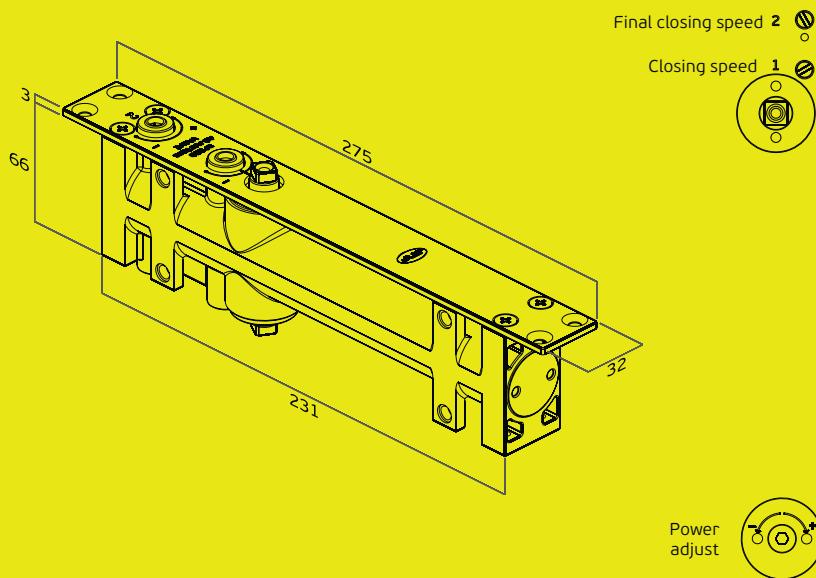

- 1** **Corpo /**
Body /
Cuerpo /

- 2** **Barra de fixação /**
Fixing plate /
Barra de sujeción /

- 3** **Braço /**
Stainless steel cover /
Cubierta en acero inoxidable /

- 4** **Calha /**
Track /
Cubierta RAL 9006 /

- 5** **Terminal /**
Terminal /
Terminal /

FREELINE RANGE



FREELINE

ML.21.800

Mola de porta aérea hidráulica de embutir para portas de batente.

Braço anti-vandalismo

Força: 3

Largura máxima de porta: 950 mm

Peso máximo de porta: 65 kg

Mecanismo cremalheira e pinhão

Velocidade de fecho ajustável por válvula

Velocidade de fecho final ajustável por válvula

Sistema de retenção na abertura : amovível

Ângulo de abertura 120°

Mola reversível

Concealed hydraulic overhead door closer to single action.

Sliding Arm

Power: 3

Maximum door width: 950 mm

Maximum door weight: 65 kg

Rack and pinion mechanism

closing speed adjustable by valve

Lathing speed adjustable by valve

Hold open system: revolvable

Opening angle 120°

Reversible door closer

Cierra puertas hidráulico de embutir para puertas de batiente.

Brazo antivandalismo

Fuerza: 3

Ancho máximo de puerta: 950 mm

Peso máximo de puerta: 65 kg

Mecanismo de piñon y cremallera

Velocidad de cierre ajustable por válvula

Velocidad de golpe final ajustable por válvula

Sistema de retención en la apertura: extraíble

Ángulo de apertura 120°

Cierra puertas reversible

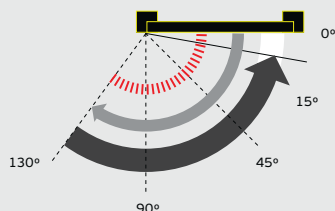



 Abertura /
 Opening /
 Apertura.

 Velocidade de fecho
 Closing speed /
 Velocidade de freno.

 Velocidade do fecho final
 Final closing speed /
 Velocidade de golpe final.

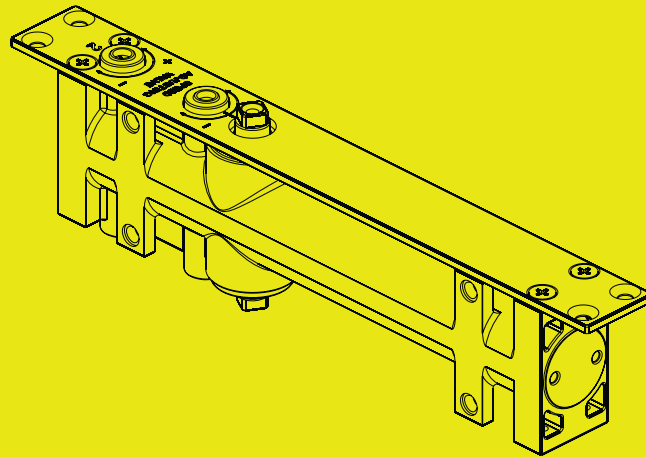
 Retenção na abertura : amovível /
 Hold open system: revolvable
 retención en la apertura: extraíble.



Final closing speed **2**

Closing speed **1**



Power
adjust

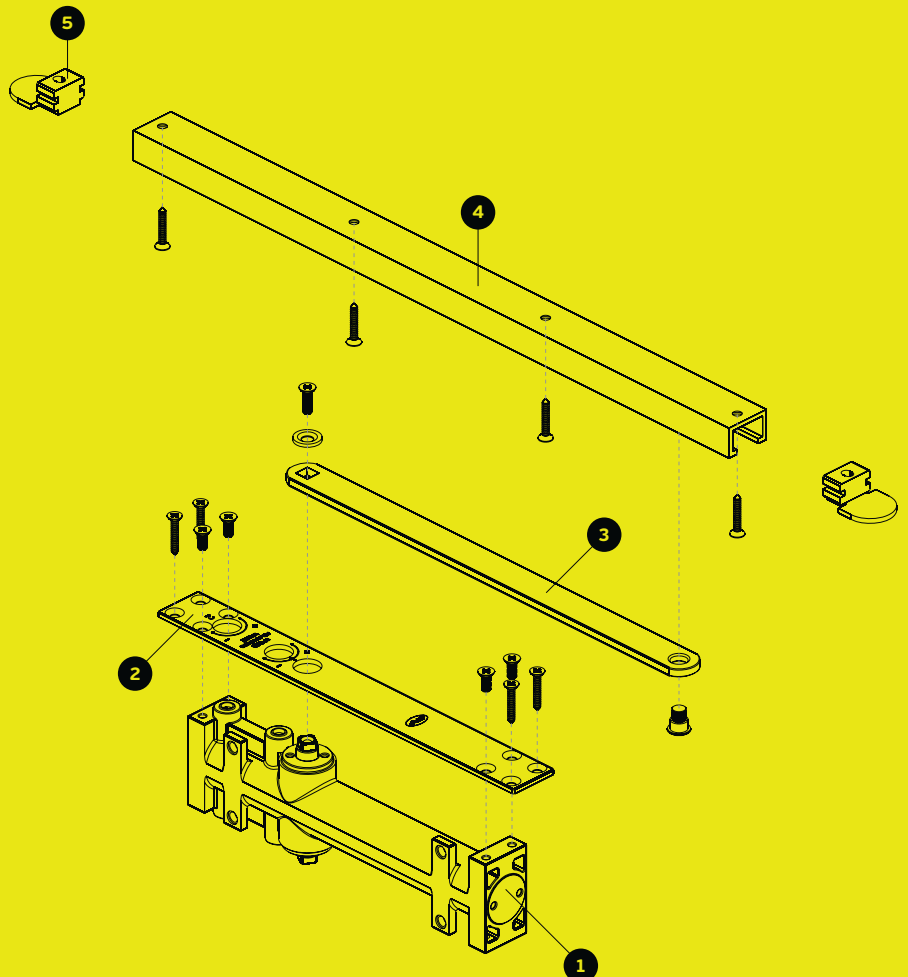

- 1** Corpo /
Body /
Cuerpo /

- 2** Barra de fixação /
Fixing plate /
Barra de sujeción /

- 3** Braço /
Stainless steel cover /
Cubierta en acero inoxidable /

- 4** Calha /
Track /
Cubierta RAL 9006 /

- 5** Terminal /
Terminal /
Terminal /



Acessórios para Molas de portas aéreas /

Aerial door Closers Accessories / Accesorios para Cierra Puertas aéreas.

21.BIM.760 / 21.BIM.765 / 21.BIM.770

Placa intermédia, para instalação de molas em portas corta-fogo ou como pré - instalação /

Mounting backplate, for installation of the door closer on fireproof and smoke control rooms or as pre mounting plate / Placa intermedia, para aplicación del cierra puertas en puertas resistentes al fuego o como pre-montaje.

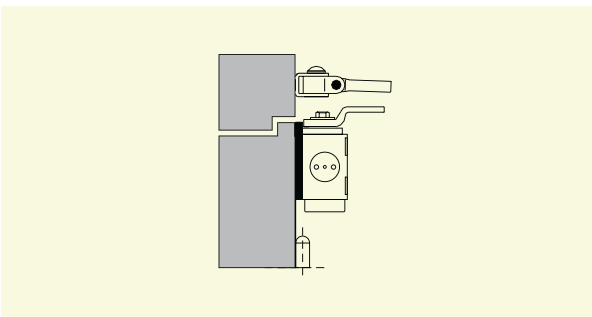
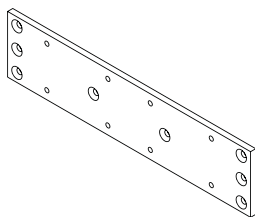

21.BMV.760 / 21.BMV.765

Base para vidro, para instalação de molas em portas de vidro / Glass door shoe, for installation of the door closer to all glass doors / Base para cristal,

para aplicación del cierra puertas en puertas de cristal.

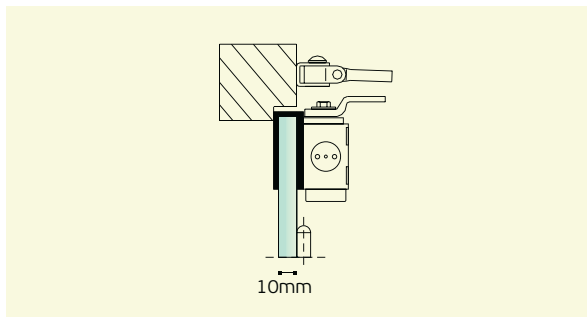
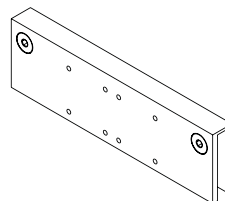

21.BBP /

Base para instalação do braço em paralelo /

Plate for installation of the parallel arm / Base para aplicación del brazo paralelo.

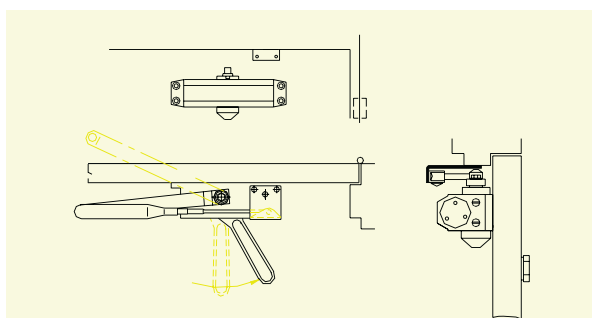
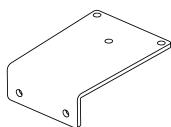

21.110 /

Braço standard com retenção ajustável. RAL 9006 /

Standard arm with adjustable hold open function. RAL 9006 / Brazo standard con retención ajustable. RAL 9006.

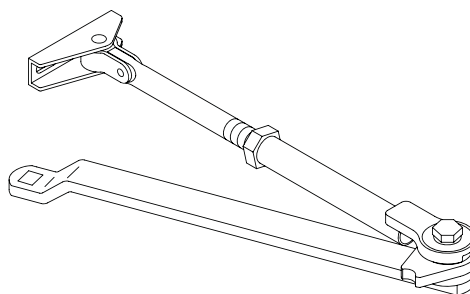

21.201.Q

EN 1.4301 Satinado / Satin / Satin

Cobertura para mola /

cover for door closer / Cobertura Cierra puertas :

ML.21.775 + ML.21.765 + ML.21.760 INOX



21.202.Q

EN 1.4301 Satinado / Satin / Satin

Cobertura para mola /

cover for door closer / Cobertura Cierra puertas :

ML.21.770 INOX



21.203

EN 1.4301 Satinado / Satin / Satin

Cobertura para mola /

cover for door closer / Cobertura Cierra puertas :

ML.21.775



21.204

RAL 9006

Cobertura para mola /

cover for door closer / Cobertura Cierra puertas :

ML.21.775 + ML.21.765 + ML.21.760





Acessórios para Molas de portas aéreas /

Aerial door Closers Accessories / Accesorios para Cierra Puertas aéreas.

21.500

Selector de fecho para portas duplas com mola instalada. Reversível, em alumínio anodizado. /

Door coordinator for double doors with door closer installed. Reversible, anodized aluminum. /

Selector de cierre para puertas doble con cierra puertas instalado. Reversible, aluminio anod /

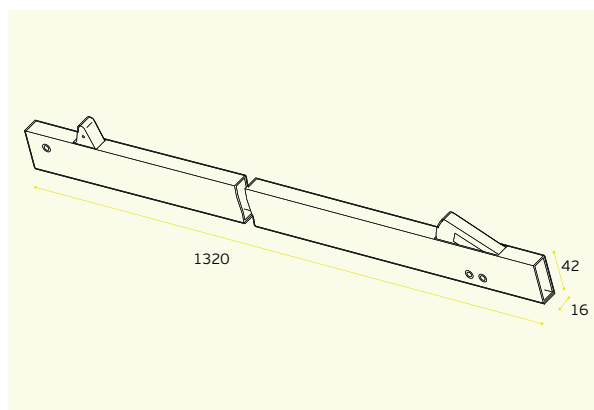

21.501

Extensão para selector de fecho 21.500. /

Extension for door coordinator 21.500. /

Extensión para selector de cierre 21.500. /

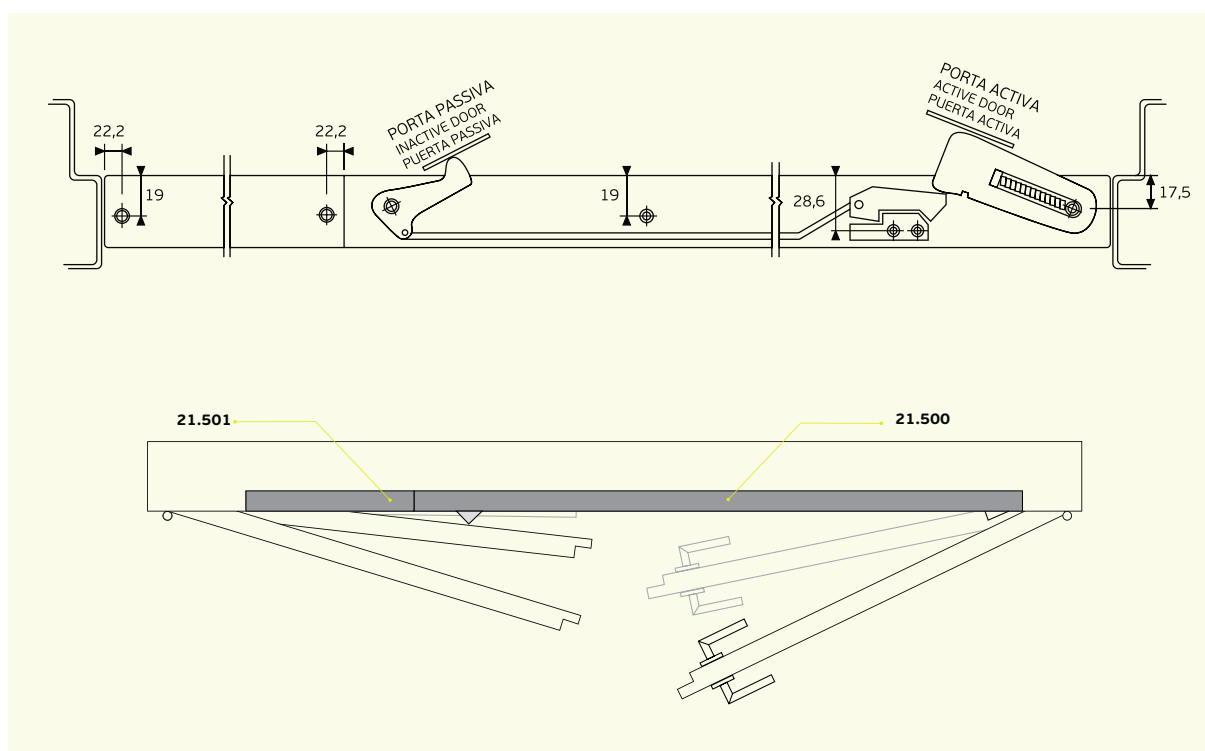
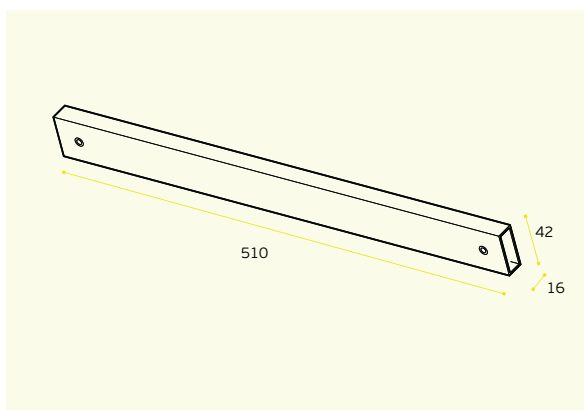

21.502

Selector de fecho para portas duplas
Pode ser instalado com molas aéreas JNF
como IN.21.760 / 765/770/775

É útil em aplicações onde as portas estão
normalmente fechadas.

O selector é integrado dentro de
um carril que o protege de vandalismo.

É indicado para todos os tipos de portas
duplas, entradas de escritório, edifícios
comerciais, hotéis, etc ...

O selector de fecho mantém a porta
activa aberta quando a porta inactiva
está aberta. Porta activa começa a fechar
quando a porta inativa está fechada.

Mechanical door coordinator for double
doors. Can be installed with JNF overhead
door closer like IN.21.760/765/770/775
Is useful in applications where doors are
normally kept closed.

The coordinator is integrated inside the
covered sliding rails which protects the
coordinator from abuse.

Is suitable for all kinds of double doors,
entrance halls in office and commercial
buildings, hotels, etc...

Mechanical coordinator keeps the active
door open when inactive door is open. Active
door starts to close when the inactive door is
almost closed.

Selector de cierre para puertas dobles
Se puede instalar con los cierra puertas
JNF como IN.21.760 / 765/770/775

Es útil en aplicaciones en que las puertas
están normalmente cerradas.

El selector está integrado en un carril que
lo protege do abuso. Es apto para todo tipo
de puertas dobles, entradas a la oficina,
edifícios comerciales, hoteles, etc ...

Lo selector mantiene la puerta activa
abierta cuando la puerta está inactiva
abierta. Puerta activa comienza a cerrarse
cuando la puerta está inactiva cerrada.

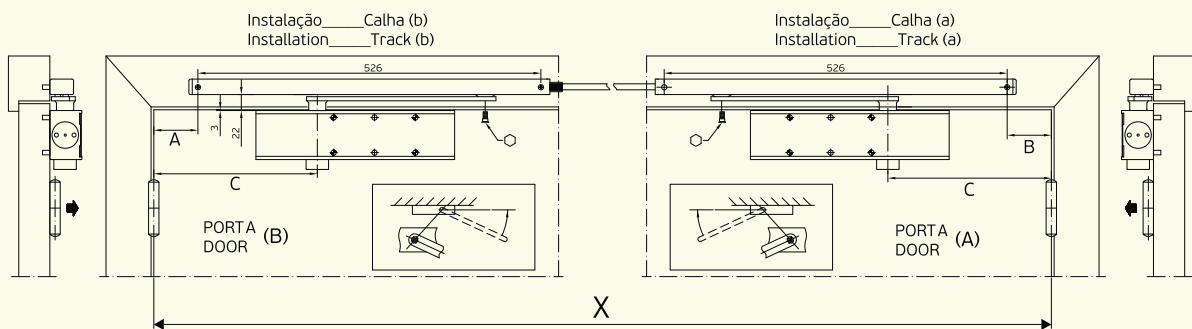

X	1500-1700	1700-1930
A	68	148
B	50	130
C	110	190

(unit: mm)

PORTA DOOR (A) porta que fecha 1º
door closes first
PORTA DOOR (B) porta que fecha em 2º
door closes second

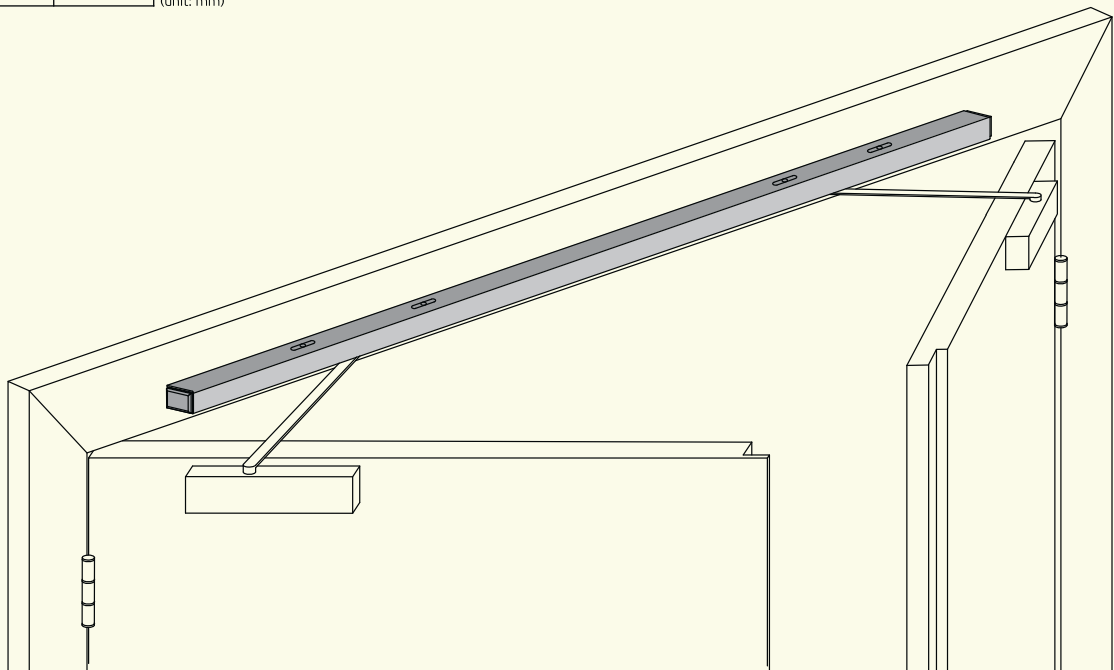

H/1288

■■■
Sistemas de fecho /
Locking systems /
Sistemas de cierre

■
Molas de pavimento /
Floor closers /
Cierra puertas de suelo.

■
www.jnf.pt

MOLAS DE PAVIMENTO / FLOOR CLOSERS / CIERRA PUERTAS DE SUELO

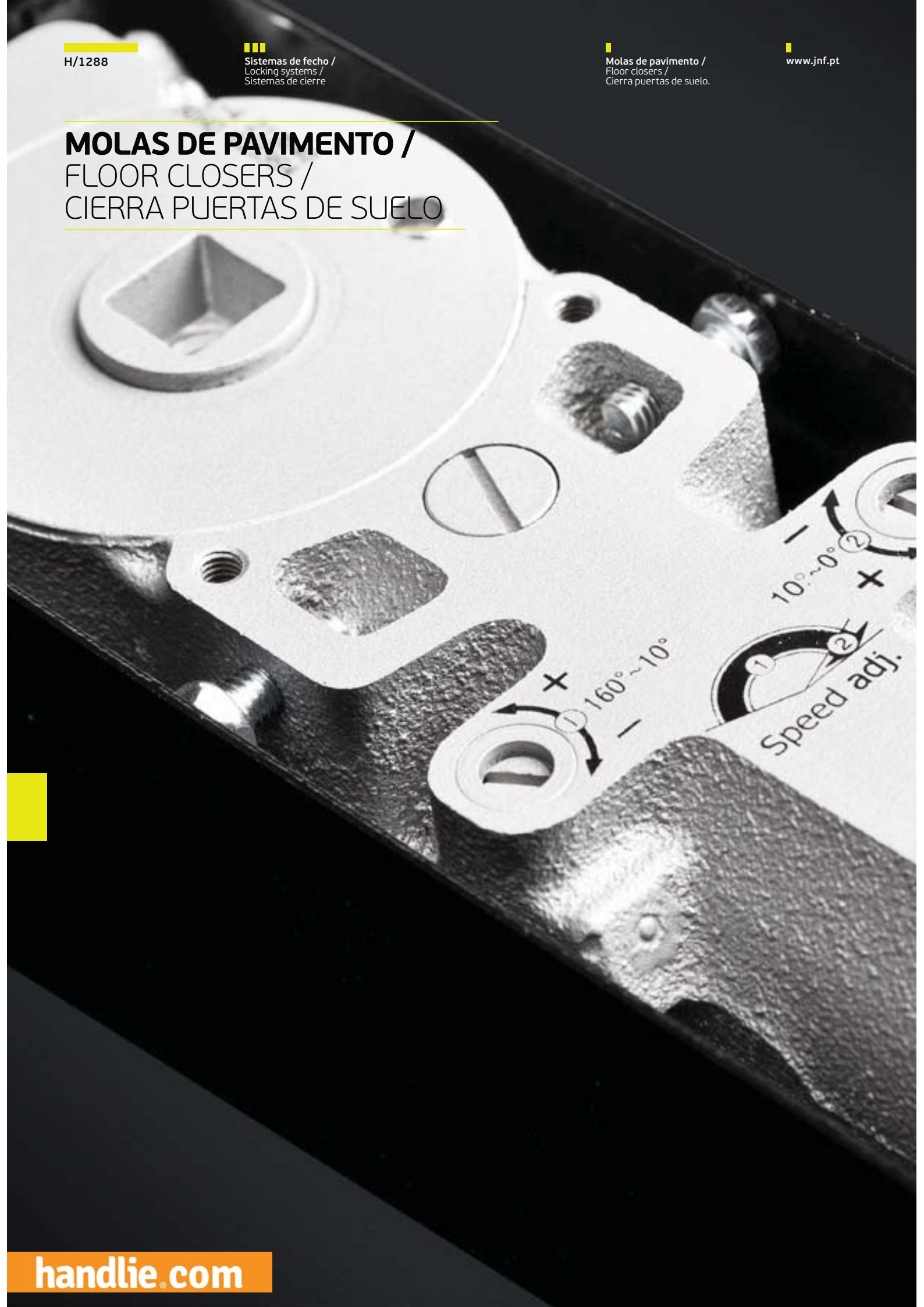



Molas de pavimento /
Floor closers /
Cierra puertas de suelo.



Compliant with

3	8	4	1	1	3
EN 1154:1996+A1:2002					



MOLAS DE PAVIMENTO / FLOOR CLOSERS / CIERRA PUERTAS DE SUELO



21.2205

Mola de pavimento com paragem 90° /
 Floor door closer with hold open position 90° /
 Cierra puerta de pavimento con retención a 90°.



**Mola de pavimento para portas de batente
 ou vai-vém aplicável em portas de madeira,
 metálicas ou de vidro.**

Características:

- Para portas com peso até 200 Kg
- Velocidade ajustável por válvulas
- Força de fecho variável (válvula C) através de uma válvula hidráulica desde os 160° aos 0°
- Duas válvulas de ajuste para controlo independente da velocidade desde 160°-10° (válvula A) a 10°-0°(válvula B).
- Ciclos de teste: mais de 500 000
- Garantia: 5 anos

Floor closer for single action doors or double
 action door, applicable to wood, mettalic or glass
 doors.

Specifications:

- For doors with weight up to 200 kg
- Adjustable Speed .
- Power of latching (Valve C) changeable through a hydraulical valve since 160° to 0°
- Two independent valves of adjustment of latching speed controlling since 160°-10° (Valve A) to 10°-0° (Valve B).
- Cycles of test: more than 500 000
- Guarantee: 5 years

Cierra puertas de suelo para puertas de batiente
 o doble acción, aplicable a puertas de madera,
 metálicas o de cristal.

Especificaciones:

- Para puertas con peso hasta 200 kg
- Velocidad ajustable
- Fuerza del cierre ajustable (Válvula C) por válvula hidráulica desde 160° a 0°
- Dos válvulas independientes para ajuste del cierre que controla la velocidad desde los 160°-10°(Válvula A) hasta 10°-0° (Válvula B).
- Ciclos de la prueba: más de 500 000
- Garantía: 5 años

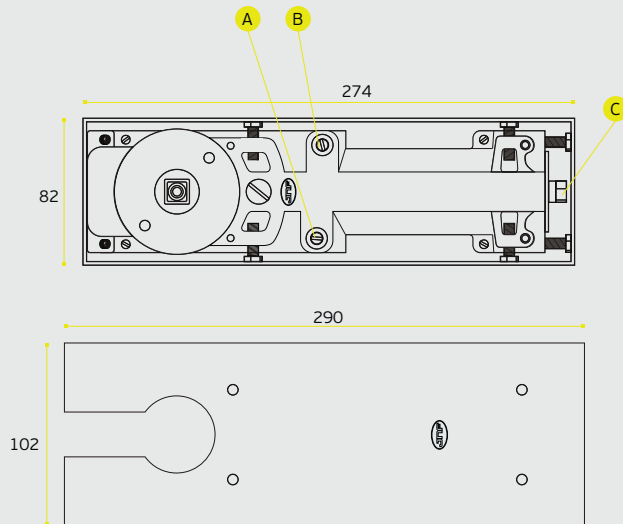

Personalizável / Customisable / Personalizable

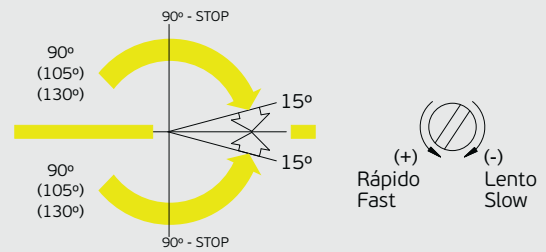

Aplicável com quadra
21.001.Q (standard - 17x17mm) /
Applicable with spindle
21.001.Q (standard - 17x17mm) /
Aplicable con cuadradillo
21.001.Q (standard - 17x17mm).



Aplicável com quadra
21.001.R (22x11,6mm) /
Applicable with spindle
21.001.R (22x11,6mm) /
Aplicable con cuadradillo
21.001.R (22x11,6mm).



Aplicável com quadra
21.001.QS (13x13mm) /
Applicable with spindle
21.001.QS (13x13mm) /
Aplicable con cuadradillo
21.001.QS (13x13mm).

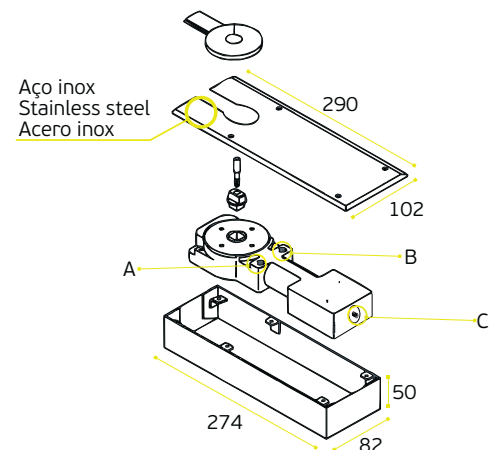

MOLAS DE PAVIMENTO /

FLOOR CLOSERS /

CIERRA PUERTAS DE SUELO



NEW

EN
1154

 200
kg
2/4
power

21.2205.B

Mola de pavimento sem paragem 90° /
 Floor door closer no hold open position 90° /
 Cierra puerta de pavimento sin retención a 90°.

Mola de pavimento para portas de batente
 ou vai-vém aplicável em portas de madeira,
 metálicas ou de vidro.

Características:

- Para portas com peso até 200 Kg
- Velocidade ajustável por válvulas
- Força de fecho variável (válvula C) através de uma válvula hidráulica desde os 160° aos 0°
- Duas válvulas de ajuste para controlo independente da velocidade desde 160°-10° (válvula A) a 10°-0° (válvula B).
- Ciclos de teste: mais de 500 000
- Garantia: 5 anos

Floor closer for single action doors or double
 action door, applicable to wood, mettalic or glass
 doors.

Specifications:

- For doors with weight up to 200 kg
- Adjustable Speed .
- Power of latching (Valve C) changeable through a hydraulical valve since 160° to 0°
- Two independent valves of adjustment of latching speed controlling since 160°-10° (Valve A) to 10°-0° (Valve B).
- Cycles of test: more than 500 000
- Guarantee: 5 years

Cierra puertas de suelo para puertas de batiante
 o doble acción, aplicable a puertas de madera,
 metálicas o de cristal.

Especificaciones:

- Para puertas con peso hasta 200 kg
- Velocidad ajustable
- Fuerza del cierre ajustable (Válvula C) por válvula hidráulica desde 160° a 0°
- Dos válvulas independientes para ajuste del cierre que controla la velocidad desde los 160°-10°(Válvula A) hasta 10°-0° (Válvula B).
- Ciclos de la prueba: más de 500 000
- Garantía: 5 años

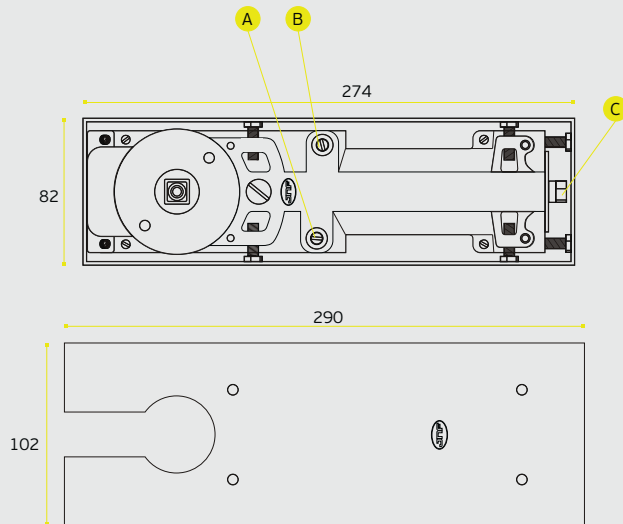

Personalizável / Customisable / Personalizable

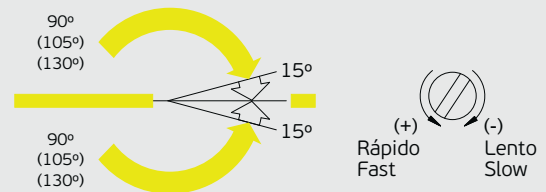

Aplicável com quadra
21.001.Q (standard - 17x17mm) /
Applicable with spindle
21.001.Q (standard - 17x17mm) /
Applicable con cuadradillo
21.001.Q (standard - 17x17mm).



Aplicável com quadra
21.001.R (22x11,6mm) /
Applicable with spindle
21.001.R (22x11,6mm) /
Applicable con cuadradillo
21.001.R (22x11,6mm).



Aplicável com quadra
21.001.QS (13x13mm) /
Applicable with spindle
21.001.QS (13x13mm) /
Applicable con cuadradillo
21.001.QS (13x13mm).

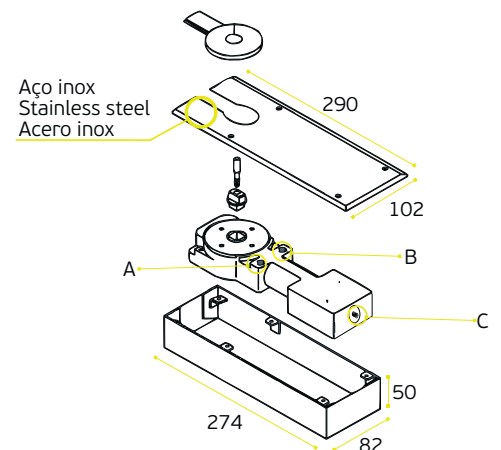

MOLAS DE PAVIMENTO / FLOOR CLOSERS / CIERRA PUERTAS DE SUELO



21.2201

Mola de pavimento /
Floor closer / Cierra puertas de suelo



Mola de pavimento para portas de batente ou vai-vém aplicável em portas de madeira, metálicas ou de vidro.

Características:

- Para portas com peso até 120 Kg
- Velocidade ajustável por válvulas hidráulica desde os 130° aos 0°
- Duas válvulas de ajuste para controlo independente da velocidade desde 130°-15° (válvula A) a 15°-0°(válvula B).
- Ciclos de teste: mais de 500 000
- Garantia: 5 anos

Floor closer for single action doors or double action door, applicable to wood, mettalic or glass doors.

Specifications:

- For doors with weight up to 120 kg
- Adjustable Speed changeable through a hydraulical valve since 130° to 0°
- Two independent valves of adjustment of latching speed controlling since 130°-15° (Valve A) to 15°-0° (Valve B).
- Cycles of test: more than 500 000
- Guarantee: 5 years

Cierra puertas de suelo para puertas de batiente o doble acción, aplicable a puertas de madera, metalicas o de cristal.

Especificaciones:

- Para puertas con peso hasta 120 kg
- Velocidad ajustable por válvula hidráulica desde 130° a 0°
- Dos válvulas independientes para ajuste del cierre que controla la velocidad desde los 130°-15°(Válvula A) hasta 15°-0° (Válvula B).
- Ciclos de la prueba: más de 500 000
- Garantía: 5 años

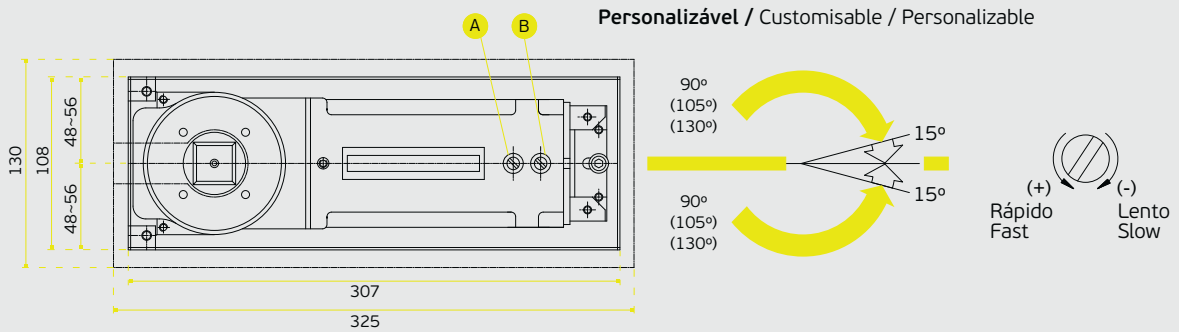

Aplicável com quadra
21.001.Q (standard - 17x17mm) /
Applicable with spindle
21.001.Q (standard - 17x17mm) /
Applicable con cuadradillo
21.001.Q (standard - 17x17mm).



Aplicável com quadra
21.001.R (22x11,6mm) /
Applicable with spindle
21.001.R (22x11,6mm) /
Applicable con cuadradillo
21.001.R (22x11,6mm).



Aplicável com quadra
21.001.QS (13x13mm) /
Applicable with spindle
21.001.QS (13x13mm) /
Applicable con cuadradillo
21.001.QS (13x13mm).

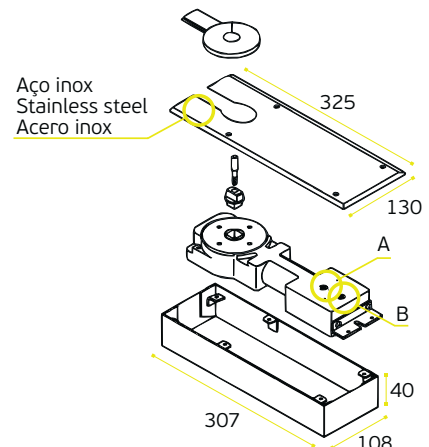

MOLAS DE PAVIMENTO / FLOOR CLOSERS / CIERRA PUERTAS DE SUELO



21.2203

Mola de pavimento /
Floor closer / Cierra puertas de suelo



Mola de pavimento para portas de batente ou vai-vém aplicável em portas de madeira, metálicas ou de vidro.

Características:

- Para portas com peso até 50 Kg
- Velocidade ajustável por válvulas hidráulica desde os 130° aos 0°
- Duas válvulas de ajuste para controlo independente da velocidade desde 130°-15° (válvula A) a 15°-0°(válvula B).
- Ciclos de teste: mais de 500 000

Floor closer for single action doors or double action door, applicable to wood, mettalic or glass doors.

Specifications:

- For doors with weight up to 50kg
- Adjustable Speed changeable through a hydraulical valve since 130° to 0°
- Two independent valves of adjustment of latching speed controlling since 130°-15° (Valve A) to 15°-0° (Valve B).
- Cycles of test: more than 500 000

Cierra puertas de suelo para puertas de batiente o doble acción, aplicable a puertas de madera, metalicas o de cristal.

Especificaciones:

- Para puertas con peso hasta 50 kg
- Velocidad ajustable por válvula hidráulica desde 130° a 0°
- Dos válvulas independientes para ajuste del cierre que controla la velocidad desde los 130°-15°(Válvula A) hasta 15°-0° (Válvula B).
- Ciclos de la prueba: más de 500 000

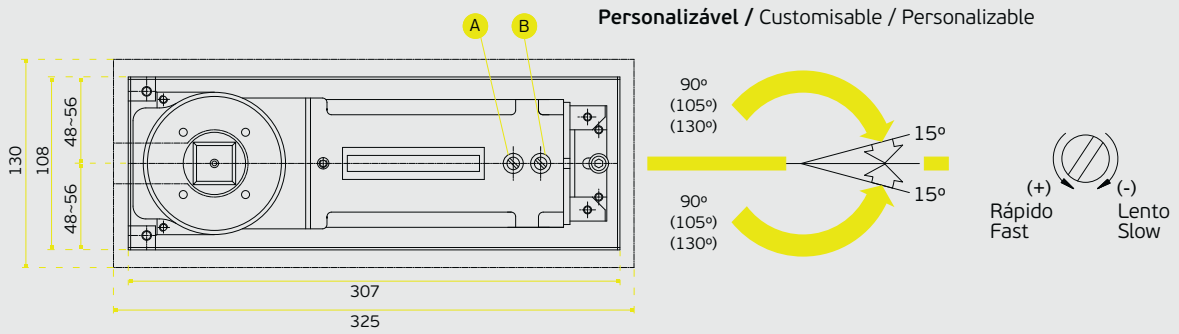

Aplicável com quadra
21.001.Q (standard - 17x17mm) /
Applicable with spindle
21.001.Q (standard - 17x17mm) /
Applicable con cuadradillo
21.001.Q (standard - 17x17mm).



Aplicável com quadra
21.001.R (22x11,6mm) /
Applicable with spindle
21.001.R (22x11,6mm) /
Applicable con cuadradillo
21.001.R (22x11,6mm).



Aplicável com quadra
21.001.QS (13x13mm) /
Applicable with spindle
21.001.QS (13x13mm) /
Applicable con cuadradillo
21.001.QS (13x13mm).

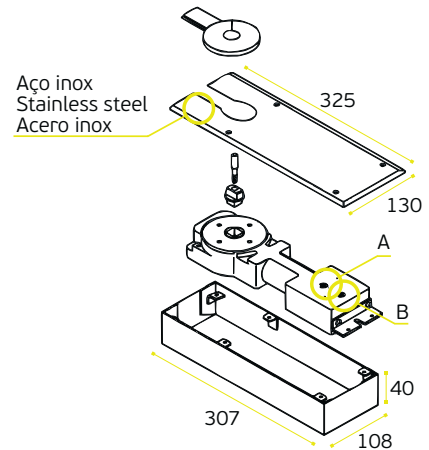

FREELINE RANGE



FREELINE



21.2207

Mola de pavimento /
Floor closer / Cierra puertas de suelo

Mola de pavimento para portas de batente ou vai-vem aplicável em portas de madeira, metálicas ou de vidro.

Características:

- Para portas com peso até 80 Kg
- Velocidade ajustável por válvulas hidráulica desde os 130° aos 0°
- Duas válvulas de ajuste para controlo independente da velocidade desde 130°-15° (válvula A) a 15°-0° (válvula B).
- Quadra fixa 21.001.Q (standard - 17x17mm)

Floor closer for single action doors or double action door, applicable to wood, mettalic or glass doors.

Specifications:

- For doors with weight up to 80 Kg
- Adjustable Speed changeable through a hydraulic valve since 130° to 0°
- Two independent valves of adjustment of latching speed controlling since 130°-15° (Valve A) to 15°-0° (Valve B).
- Fixed spindle 21.001.Q (standard - 17x17mm)

Cierra puertas de suelo para puertas de batiente o doble acción, aplicable a puertas de madera, metálicas o de cristal.

Especificaciones:

- Para puertas con peso hasta 80 Kg
- Velocidad ajustable por válvula hidráulica desde 130° a 0°
- Dos válvulas independientes para ajuste del cierre que controla la velocidad desde los 130°-15° (Valvula A) hasta 15°-0° (Valvula B).
- Cuadrillo fijo 21.001.Q (standard-17x17mm).

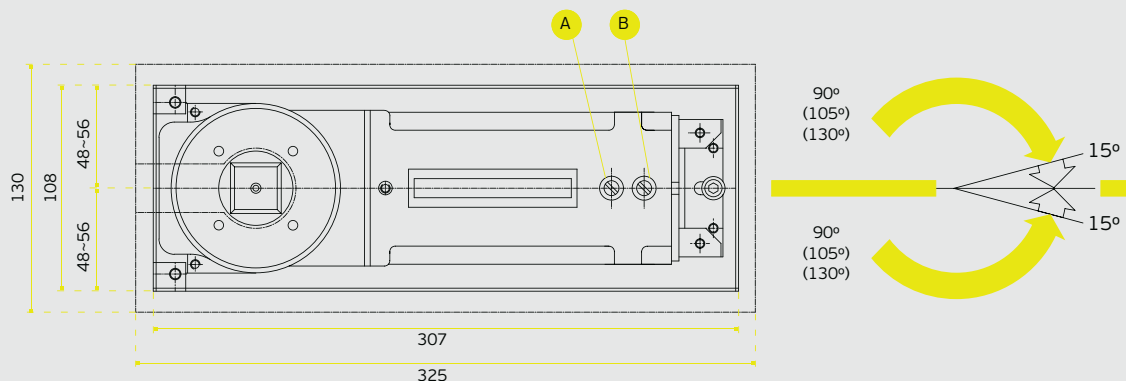

PIVOT HIDRÁULICO / HYDRAULIC PIVOT / PIVOTE HIDRÁULICO

W SYSTEM FOR GLASS

PIVOT HIDRÁULICO / HYDRAULIC PIVOT / PIVOTE HIDRÁULICO



IN.81.203 - W SYSTEM FOR GLASS

Pivot hidráulico /
Hydraulic pivot / Pivote hidráulico



Conjunto completo de pivot hidráulico para portas de vidro.

- Duas velocidades de fecho reguláveis por válvulas.
- Largura máx. da porta 1000 mm.
- Peso máx. 100 Kg.
- Espessura do vidro 8-13mm.
- Patente internacional.
- Sistema de ajuste da posição da porta $\pm 3\text{mm}$ | $\pm 3\text{mm}$ / 4° Δ (consultar dt *)
- Aplicável à superfície do pavimento

Hydraulic pivot set for glass doors

- Two speeds closing valve regulation.
- Max. door width 1000mm.
- Max. Weight up to 100 kg.
- Glass Thickness 8-13mm.
- International Patent.
- System for door position adjustment $\pm 3\text{mm}$ | $\pm 3\text{mm}$ / 4° Δ (consult dw *)
- Installation on floor surface

Juego completo de pivote hidráulico para puertas de cristal.

- Dos velocidades de cierre regulables por válvulas.
- Anchura máx. de la puerta 1000 mm.
- Peso máx. 100 Kg.
- Espesor del cristal 8-13mm.
- Patente Internacional.
- Sistema para ajustar la posición de puerta $\pm 3\text{mm}$ | $\pm 3\text{mm}$ / 4° Δ (ver dibujo *)
- Aplicable a superficie do suelo

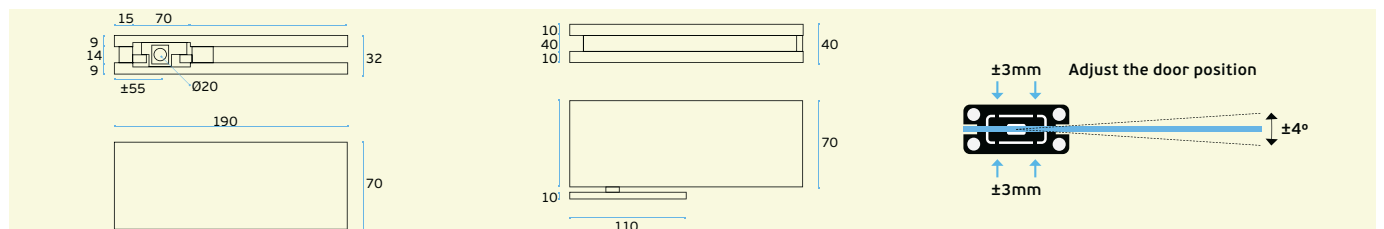

**VANTAGENS /
ADVANTAGES / VENTAJAS:**

Aplicação à superfície do pavimento
sem trabalho de alvenaria /
Application in surface the pavement
without masonry work /
Aplicación en superficie de pavimento
sin trabajos de albañilería

**WITHOUT
DAMAGE
FLOOR**

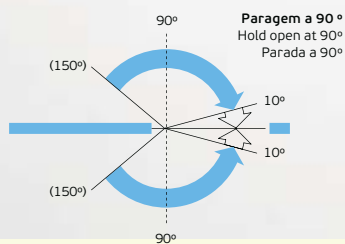
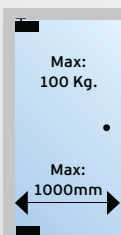
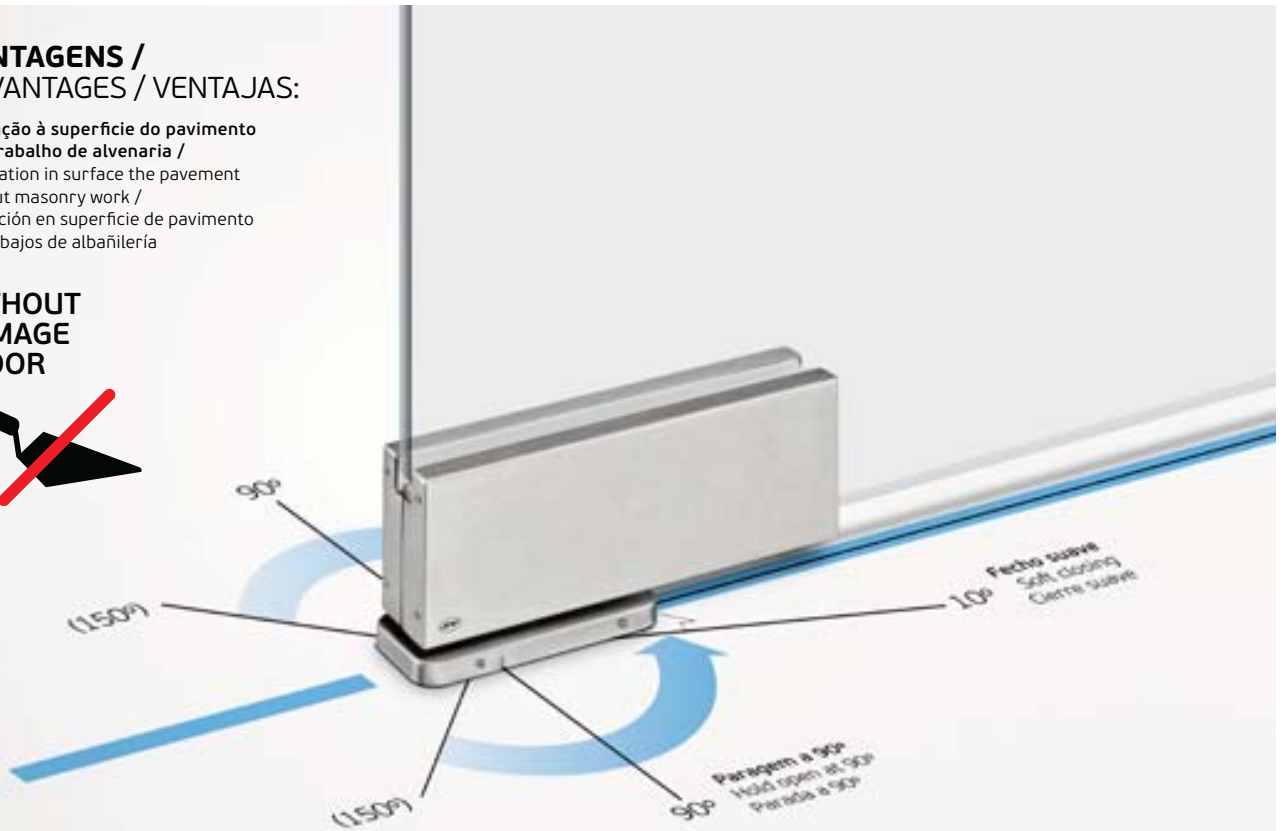

Fornecido com pivot
para tecto IN.81.106/
Supplied with ceiling
pivot IN.81.106/
suministrado con pivote
para techo.

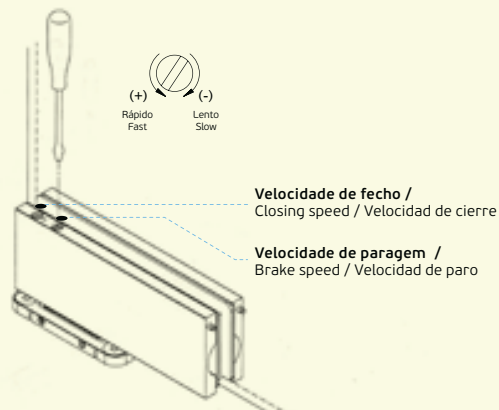

PIVOT HIDRÁULICO / HYDRAULIC PIVOT / PIVOTE HIDRÁULICO

W SYSTEM FOR WOOD





■
Molas de pavimento /
Floor closers /
Cierra puertas de suelo.

■
H/1303

PIVOT HIDRÁULICO / HYDRAULIC PIVOT / PIVOTE HIDRÁULICO



IN.05.204 W SYSTEM FOR WOOD

Pivot hidráulico /
Hydraulic pivot / Pivote hidráulico

Conjunto completo de pivot
hidráulico para portas de madeira.

- Duas velocidades de fecho reguláveis por válvulas.
- Largura máx. da porta 1000 mm.
- Peso máx. 100 Kg.
- Espessura da porta ≥ 40 mm.
- Patente internacional.
- Sistema de ajuste da posição da porta ± 3 mm | ± 3 mm / 4° \triangle (consultar dt *)
- Aplicavel à superfície do pavimento

Hydraulic pivot set for wood doors

- Two speeds closing valve regulation.
- Max. door width 1000mm.
- Max. Weight up to 100 kg.
- Wood Thickness ≥ 40 mm.
- International Patent.
- System for door position adjustment ± 3 mm | ± 3 mm / 4° \triangle (consult dw *)
- Installation on floor surface



Juego completo de pivote hidráulico
para puertas de madera.

- Dos velocidades de cierre regulables por válvulas.
- Anchura máx. de la puerta 1000 mm.
- Peso máx. 100 Kg.
- Espesor del madera ≥ 40 mm.
- Patente Internacional.
- Sistema para ajustar la posición de puerta ± 3 mm | ± 3 mm / 4° \triangle (ver dibujo *)
- Aplicable a superficie do suelo

Max:
100 Kg.

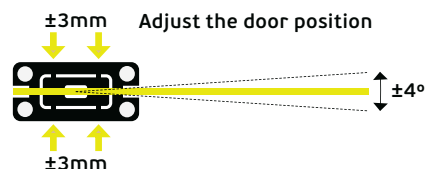

**VANTAGENS /
ADVANTAGES / VENTAJAS:**

**Aplicação à superfície
do pavimento sem trabalho
de alvenaria /**
Application in surface the pavement
without masonry work /
Aplicación en superficie de
pavimento sin trabajos de albañilería

**WITHOUT
DAMAGE
FLOOR**

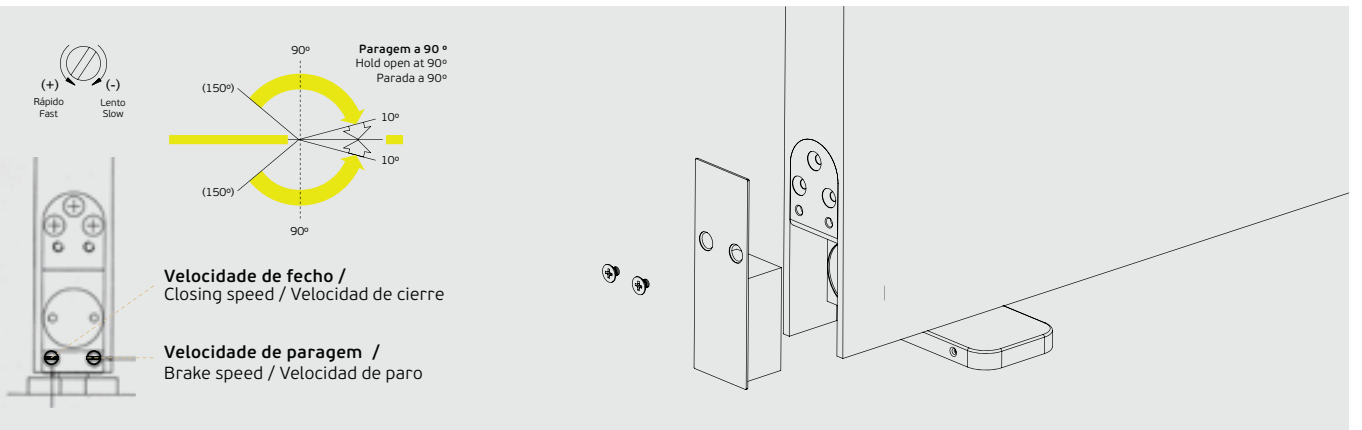
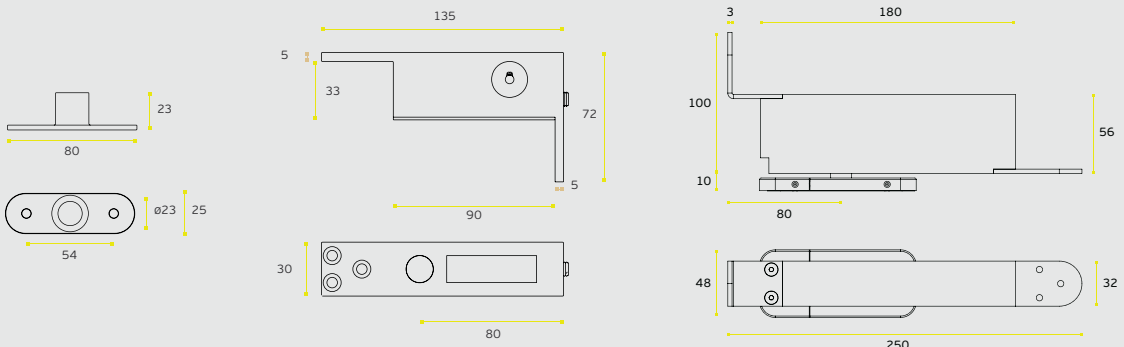



Acessórios para Molas de pavimento /

Floor closers Accessories / Accesorios para cierra puertas de suelo.

21.2200.W

**Pivot para portas de dupla ação.
para aplicar com quadra 21.001R /**
Double action doors pivot. To use with spindle 21.001.R /
Pivote para puertas de doble acción. Aplicar con el
cuadrillo 21.001.R /



21.2200.D

21.2200.E
Braço de batente para mola de pavimento /
Stopper arm for floor closer /
Brazo de tope para cierra puertas de suelo /



21.001.Q

Quadra standard - 17x17mm. /
Standard spindle - 17x17mm. /
Cuadradillo standard - 17x17mm.

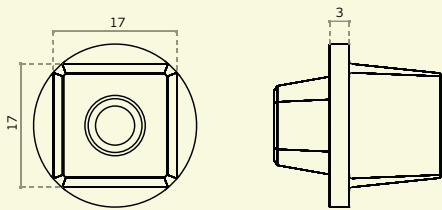

21.001.R

Quadra rectangular - 22x11,6mm. /
Rectangular spindle - 22x11,6mm. /
Cuadradillo rectangular - 22x11,6mm.

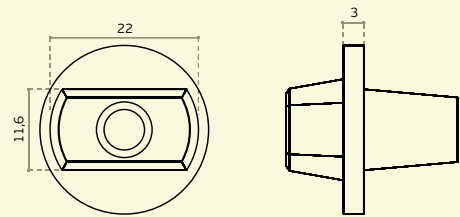

21.001.QS

Quadra - 13x13mm. /
spindle - 13x13mm. /
Cuadradillo - 13x13mm.

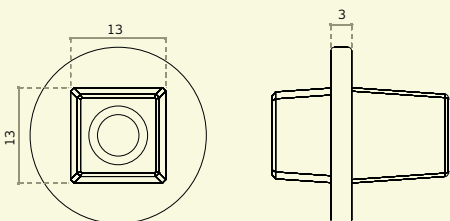

21.001.R10

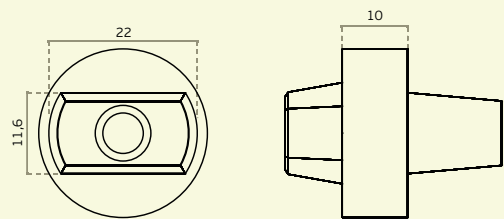

21.001.R20

