

**KLEVA<sup>®</sup>**  
**MIGHTY MIX<sup>™</sup>**  
**STICK BLENDER**

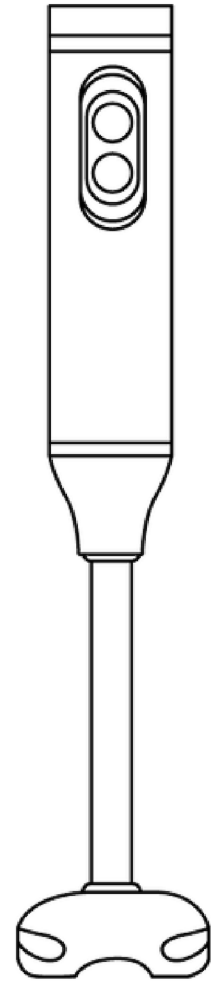
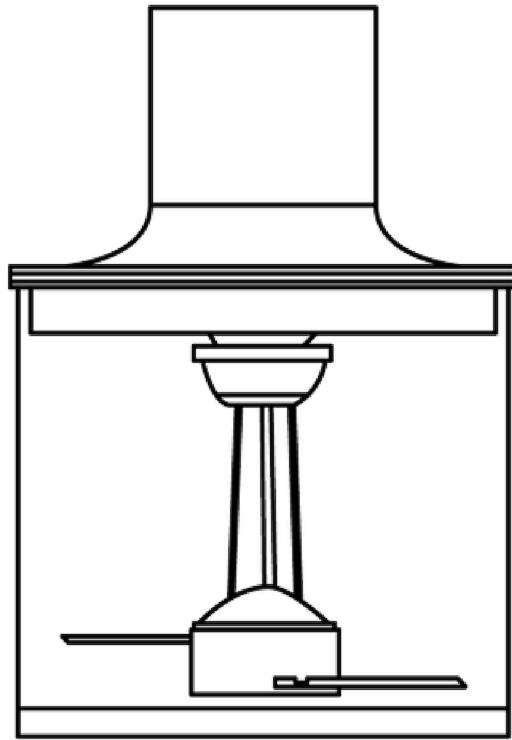
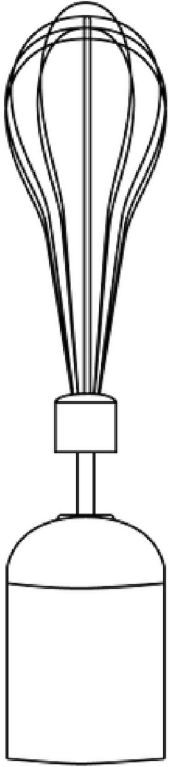

**MODEL: KRSTICKB-01**

# USER MANUAL

Please read this **User Guide** carefully before use  
& keep it handy for future reference.

# SAFETY WARNINGS



Read these instructions carefully before switching on the appliance and keep them for future reference. Failure to follow and observe these instructions could lead to an accident. Before use, clean all parts of the product that will be in contact with food, as indicated in the cleaning section. **This appliance is not suitable for children. Keep the unit and accessories out of reach of children.**

## IMPORTANT GENERAL USE:

- This product is not suitable for use by individuals (including children) who have limited physical, sensory, cognitive abilities or lack of experience and knowledge, unless they have supervision.
- Children should be supervised to ensure that they do not play with the appliance.
- If the supply cord is damaged, it must be replaced by the manufacturer, its service agent or similarly qualified individuals, in order to avoid a hazard.
- This appliance is intended for use in household and similar applications such as:
  - a. staff kitchen areas in retail outlets, offices and other working environments;
  - b. farm houses;
  - c. by clients in hotels, motels and other residential type environments;
  - d. bed and breakfast environments.
- This appliance is not a toy. Children should be supervised to ensure that they do not play with the appliance.
- Blades are sharp and could cause harm, be careful and avoid direct contact with the blades' cutting edges.
- Pay special attention when handling the blades, when assembling/disassembling the unit, emptying the bowl and during cleaning. Always switch off the appliance and disconnect from supply when left unattended, before changing accessories, approaching parts that move in use, assembling, disassembling and cleaning.
- If the connection to the mains has been damaged, it must be replaced immediately, please get in touch with the Kleva Range Customer Service Team to organise next steps. To avoid a hazard, do not attempt to disassemble or repair the appliance by yourself.
- Ensure that the voltage indicated on the rating label matches the mains voltage before plugging in the appliance.
- Connect the appliance to a socket that can supply a minimum of 10 amperes.
- The appliance's plug must fit into the mains socket properly. Do not alter the plug.
- Do not use plug adaptors.
- Keep the working area clean and well lit. Cluttered and dark areas invite accidents.
- Keep children and bystanders away when using this appliance.

# SAFETY WARNINGS

- Do not use the appliance if the cable or plug is damaged. If any of the appliance casings break, immediately disconnect the appliance from the mains to prevent the possibility of an electric shock.
- Do not use the appliance if it has fallen on the floor, if there are visible signs of damage or if it has a leak.
- Do not use the appliance with damp hands or feet, or when barefooted.
- Do not force the power cord. Never use the power cord to lift up, carry or unplug the appliance.
- Do not wrap the power cord around the appliance.
- Check the state of the power cord. Damaged or tangled cables increase the risk of electric shock.
- The appliance is not suitable for outdoor use.
- Supply/Power cord should be regularly examined for signs of damage, and if the cord is damaged, the appliance must not be used.
- Do not use or store the appliance outdoors.
- Do not touch the plug with wet hands.
- Take the necessary measures to avoid starting the appliance involuntarily.
- Before using the appliance ensure that the blade is properly fixed in place.
- Exercise precaution after employing the stop operation on the appliance as the blade/s will continue moving from the effect of its own mechanical inertia.
- The temperature of the accessible surfaces may be high when the appliance is in use.

## **WARNING/ MUST READ BEFORE EVERY USE:**

- This appliance is for household use only, not professional, industrial use.
- This appliance should be stored out of reach of children and/or the disabled.
- Do not expose the appliance to extreme temperatures.
- Keep the appliance in good condition. Check that the moving parts are not misaligned or jammed and make sure there are no broken parts or anomalies that may prevent the appliance from operating correctly.
- Use the appliance and its accessories and tools in accordance with these instructions, taking into account the working conditions and the work to be performed.
- Using the appliance for operations different from those intended could result in a hazardous situation.
- Never leave the appliance connected and unattended if it is not in use. This saves energy and prolongs the life of the appliance.
- Do not use the appliance for more than 1 minute at a time. In case of operating in cycles; allow the appliance a resting period of at least 1 minute between each cycle. Under no circumstances should the appliance be operated for more time than necessary.
- As a reference in the annexed table appears several recipes, that include the amount of food to process, the recommended operating time to elaborate each recipe, as well as the time of maximum operation of the apparatus under each one of these conditions of load.

# SAFETY WARNINGS

- Do not use the appliance on any part of the body of a person or animal.
- Do not use the appliance with frozen goods or those containing bones.
- Any misuse or failure to follow the instructions for use, renders the guarantee and the manufacturer's liability null and void.



## **WARNING**

- **KEEP AWAY FROM CHILDREN.**
- Do not operate with wet hands.
- Do not use the appliance if its accessories are not properly fitted.
- Do not use the appliance if it is empty.
- Do not force the appliance's work capacity.
- Respect the MAX level indicator.
- Blades are very sharp, never put your hands or body parts near the blades.
- Fully unroll the appliance's power cable before each use.
- When using hot liquids, do not fill the jug more than half way. At all times, when mixing hot liquids in the jug, select the slowest speed on the speed selector.
- **DO NOT** use the appliance for more than 1 minute at a time.
- **DO NOT** wet/ submerge the Mighty Mix Stick Blender motor body under water.

# PARTS/FEATURES

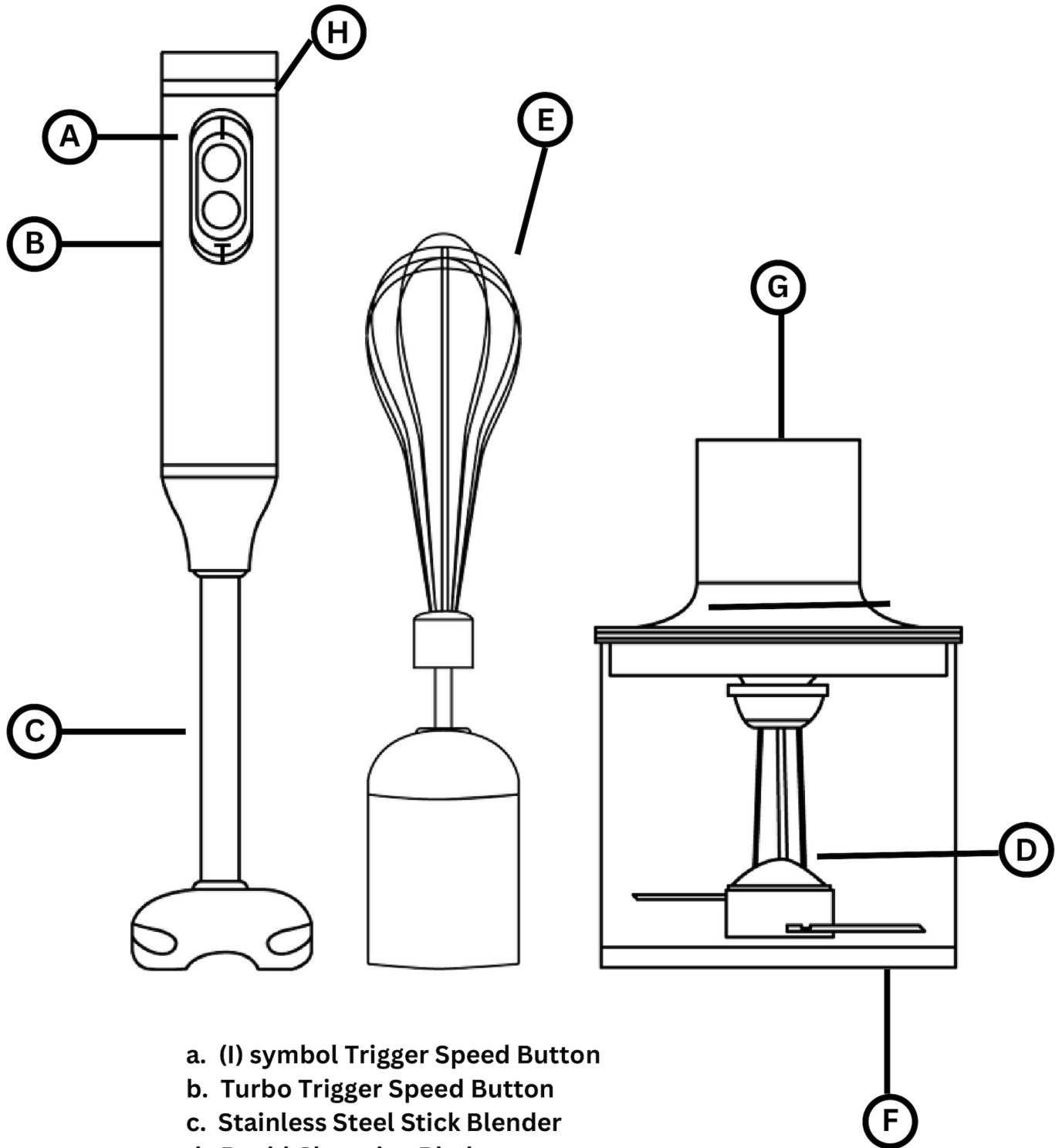

- a. (I) symbol Trigger Speed Button
- b. Turbo Trigger Speed Button
- c. Stainless Steel Stick Blender
- d. Rapid Chopping Blade
- e. Whisking Attachment
- f. Storage Container
- g. Lid
- h. Speed Dial

# DIAGRAMS

**1.3 Rapid Chopping Blade  
Figure 1**

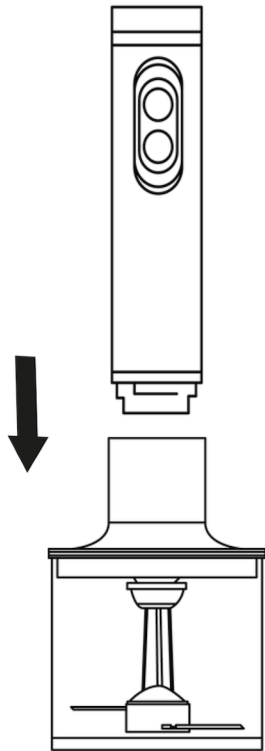

**1.4 Whisking Attachment  
Figure 2**

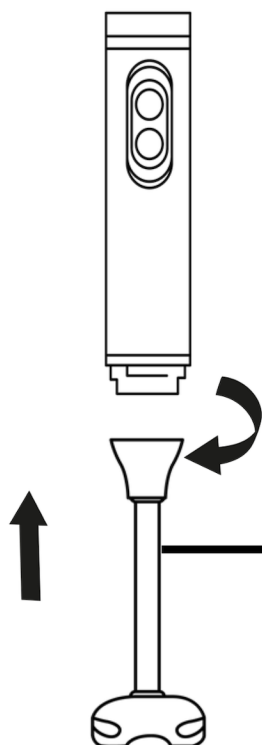
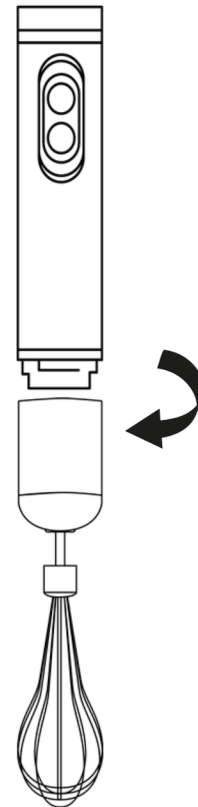

**1.4 Stainless Steel  
Blending Stick  
Figure 3**

# 1. Accessory Instructions/Assembly

## 1.1 Must apply before use:

---

1. Make sure that all the product's packaging has been removed.

**Note:** Before using the product for the first time, clean the parts that will come into contact with food in the manner described in the cleaning section.

2. Prepare the appliance according to the function you wish to use.

3. Unroll the cable completely before plugging it in and connect the power cord into a wall socket. **WARNING:** KEEP THE POWER CORD AWAY FROM ANY LIQUIDS AT ALL TIME.



**WARNING READ ALL SAFETY WARNINGS BEFORE USE.**

**DO NOT use the appliance for more than 1 minute at a time.**

## 1.2 Turbo Mode:

---

Turbo Mode is designed for fast rapid chopping, whisking and blending.

1. When using Turbo mode hold down on the 2nd button on the Mighty Mix Stick Blender™ motor body which displays a T symbol, to operate the function.

2. Release your finger from the button once your cooking task has been completed.

## 1.3 Rapid Chopping Blade:

---

The Rapid Chopping Blade is designed to create a variety of different dips, chop onions, herbs, garlic, chillies, nuts and a variety of different ingredients.

1. Place the chopping bowl on a clean and dry surface.

2. Position the blade onto the central pin of the chopping bowl and insert all ingredients for your chosen recipe. **DO NOT** overfill or force food into the chopping bowl.

3. Position the lid onto the chopping bowl and rotate it in a clockwise direction to securely lock it into place. Attach the bottom neck of the Mighty Mix Stick Blender™ motor body on the top lid of the chopping bowl and turn anticlockwise to lock (**VIEW FIGURE 1 on page 5**).

4. Plug the power cord into a wall adaptor and turn the wall socket ON. **WARNING:** Ensure you do not press the 2x Buttons on the Mighty Mix Stick Blender™ motor body which are the Trigger Speed Button and the Turbo Button until you the unit is in the mix bowl and you are ready to blend. **DO NOT** face the unit towards your face or body. **DO NOT** touch the blades.

5. Adjust to your chosen blending speed, by turning the speed dial from 1 - 5 (1 being the lowest speed and 5 being the highest) Turn dial to the left for increased speed. Once your speed has been selected press down on the top trigger speed button which shows an (I) symbol to start the chopping process. **Note:** you will need to leave your finger on the trigger speed button for the unit to operate.

6. Once you have finished chopping, release your finger from the top trigger (I) button to stop the function in use and unplug the power cord from the wall socket. To remove the Mighty Mix Stick Blender™ motor body, place one hand on the lid and hold down whilst you turn the body clockwise and pull up to remove. **WARNING:** Blades are sharp. Never put your hands near or on the blade.

# 1. Accessory Instructions/Assembly



## WARNINGS

- **MUST READ ALL WARNINGS ON PAGE 1,2&3**
- **KEEP AWAY FROM CHILDREN.**
- **Blades are very sharp. Never face the unit towards your body or any individual.**
- **DO NOT use the appliance for more than 1 minute at a time.**

## 1.4 Whisking Attachment and The Stainless Steel Blending Stick:

The **Whisking attachment** is designed to create light and fluffy textures in a variety of different dishes such as meringues, pancake batters and whipped creams.

The **Stainless Steel Blending Stick** attachment is designed to chop, mix and blend a range of different dishes such as smoothie bowls, sauces, soups, paste and more. To ensure you are getting the best result liquid is always recommended.

1. Position the mixing vessel (cup, cooking pot, or mixing bowl) on a flat, dry surface.
2. Insert your chosen attachment onto the body motor of the Mighty Mix Stick Blender™ and turn the attachment clockwise to lock into place (**VIEW FIGURE 2 and 3 on page 5**). Ensure that your chosen attachment is securely fastened to the bottom of the motor body before use.
3. Add all your chosen ingredients into your mixing bowl and ensure you do not overfill the bowl. **WARNING:** Do not blend dry and liquid ingredients all at one time, to avoid any contents overflowing.
4. Plug the power cord into a wall adaptor and turn the wall socket ON. **WARNING:** Ensure you do not press the 2x Buttons on the Mighty Mix Stick Blender™ motor body which are the Trigger Speed Button or the Turbo Button until you the unit is in the mix bowl and you are ready to blend. **DO NOT** face the unit towards your face or body. **DO NOT** touch the blades.
5. Add your assembled blending stick and chosen attachment in an upright position in your mixing bowl and select your chosen speed. Adjust to your chosen blending speed, by turning the speed dial from 1 - 5 (1 being the lowest speed and 5 being the highest. Turn dial to the left for increased speed). Once your speed has been selected press down and hold on the top trigger speed button which shows an (I) symbol to start the whisking or blending process. **NOTE:** you will need to leave your finger on the trigger speed button for the unit to operate. **WARNING:** Ensure the Stick Blender has been inserted into your mixing bowl before powering “ON” to ensure food does not splatter.
6. Once you have finished the mixing process, release your finger from the top trigger (I) button to stop the function in use and unplug the power cord from the wall socket. Once the unit is OFF and has been unplugged from the wall socket remove the Mighty Mix Stick Blender™ motor body, by gripping one hand on the body and turning the attachment anti-clockwise to unlock and remove. **WARNING:** Blades are sharp. Never put your hands near or on the blade.



## 2. Cleaning and Storage Process



### WARNINGS

- Do not use solvents, or products with an acid or base pH such as bleach, or abrasive products, for cleaning the appliance.
- Never submerge or wet the appliance in water or any other liquid or place it under running water.
- During the cleaning process, take special care with the blades, as they are very sharp.
- It is advisable to clean the appliance regularly and remove any food remains.
- If the appliance is not in good condition of cleanliness, its surface may degrade and inexorably affect the duration of the appliance's useful life and could become unsafe to use.

### 2.1 Cleaning and Storage Instructions



---

1. Unplug the Mighty Mix Stick Blender™ power cord from the wall socket. Before cleaning the attachments ensure that the unit has completely cooled down.
2. Clean each blending attachment with a damp cloth with a few drops of washing-up liquid and rinse under warm and allow it to completely dry. For the main motor body of the Mighty Mix Stick Blender. **DO NOT** submerge or wet the unit in any liquid, use a cloth to wipe it down.
3. Store in a safe place enclosed area. **WARNING:** Keep in area that is out of reach from any children. Blades are very sharp ensure that your hands do not come in contact with blade. When storing ensure that blades are never facing towards you.

**Anomalies and repair:** Get in touch with the Kleva Range Customer Service Team should any issues arise. Do not attempt to disassemble or repair the appliance yourself as this may be dangerous.

# 4. Recipes

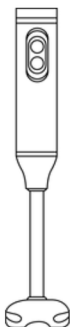
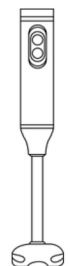
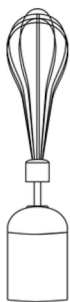
Do not exceed with using the unit for more than 1 minute per blend. If your unit requires a longer blend time then 1 minute, please turn the unit off and let it rest for a few minutes then proceed with your recipe.

RECIPE	RECOMMENDE ACCESSORY	QUANTITY	METHOD	TIME
Mayonnaise		250ml	Add 1 egg, salt, some drops of vinegar or lemon to the receptacle. Fill with oil up to the level indicated and switch on, do not move or agitate until the oil has been bound.	35s
Fruit milkshakes		---	Add the fruit and liquid in a mixing jug. Blend until smooth.	30s - 1 min
Whipped cream		250ml	Place cold cream (0 to 5°C) into a cold mixing bowl and beat with a blender, making vertical movements. Be careful not to over beat as the cream will turn to butter.	2min
Whipped egg whites		3 whites	Add the whites to a mixing bowl and whip with blender, making vertical movements.	2min

# 4. Recipes

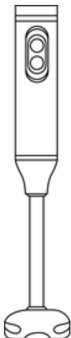
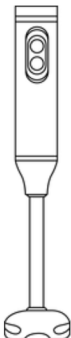
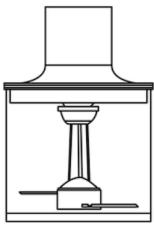
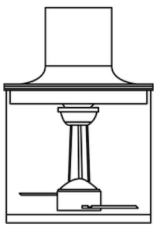
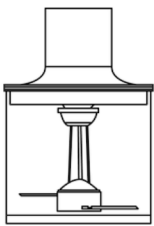
RECIPE	RECOMMENDE ACCESSORY	QUANTITY	METHOD	TIME
Baby food		300g	Cut up 100g of apples, 100g of banana, 50g of biscuits and place into a a mixing bowl. Add orange juice and blend.	25s
Mashed potatoes		400g	Potatoes can be blended while still in the saucepan. <b>Caution: Pot can be hot handle with care.</b>	30s
Grated bread		50g	Cut up stale bread and place into goblet. Blend until desired consistency is achieved.	1:30min
Grated cheese		100g	Cut into 1cm cubes and blend until desired consistency is achieved.	30-50s
Carrot		200g	Peel, dice and blend until desired consistency is achieved.	30s

**KLEVA®**  
**MIGHTY MIX™**  
**STICK BLENDER**

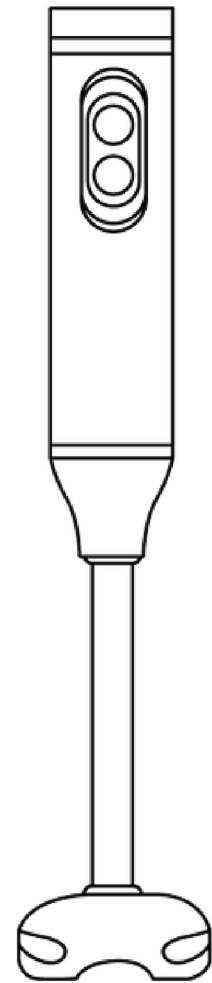
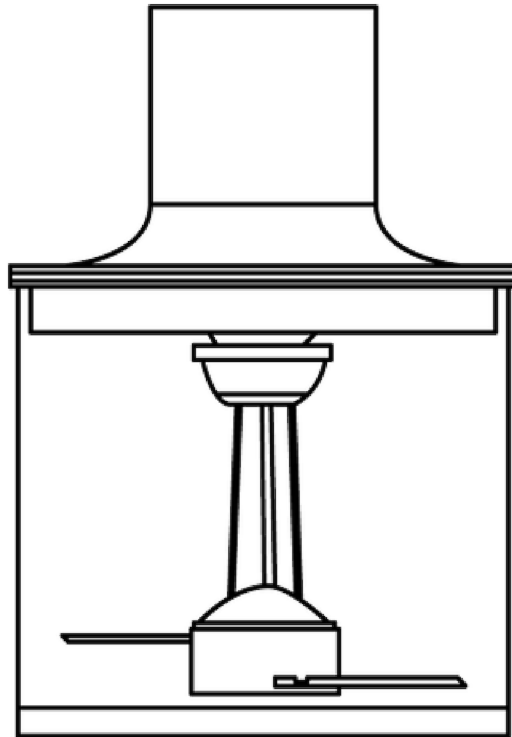
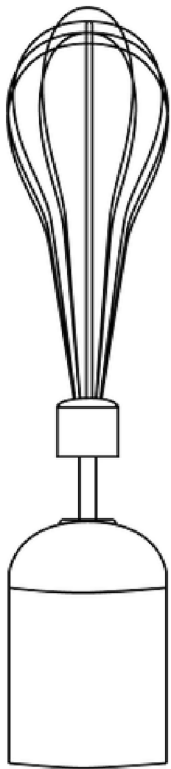

**MODEL: KRSTICKB-01**

**KLEVA RANGE®**

🌐 [www.klevarange.com.au](http://www.klevarange.com.au)

☎ 02 9387 4100

✉ [enquiries@klevarange.com.au](mailto:enquiries@klevarange.com.au)

📍 Suite 301 / 209 Oxford St

Bondi Junction NSW 2022 Australia

**GENUINE  
KLEVA  
QUALITY**

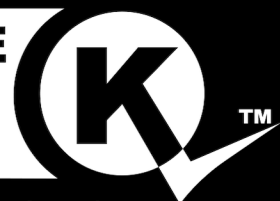

KleVA® is a registered trade mark  
of Take Two Marketing and Events Pty Ltd.