



# 2' Plain Poly Glider Assembly Instructions

- 1 - (A) Seat Assembly
- 1 - (B) Back Assembly
- 1 - (C) Glider Base right side
- 1 - (D) Glider Base left side
- 2 - (E) Front & Back Cross Pcs.
- 2 - (F) Lintels
- 2 - (G) Bearing Support Arms
- 2 - (H) Armrest Assemblies

### Hardware

- 2 - 5/16" x 3 1/2" Stainless Wafer Bolt
- 2 - 5/16" x 2 1/2" Stainless Wafer Bolt
- 4 - 5/16" x 2" Stainless Wafer Bolt
- 4 - 3/8" Nuts
- 4 - Washers
- 44 - 2" Screws
- 1 - 5/32 Hex Key

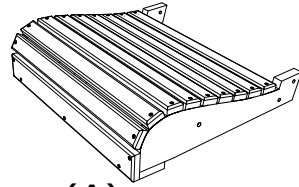

(A)



(B)

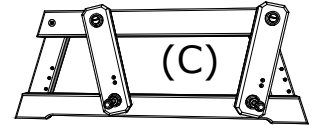

(C)

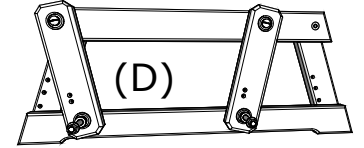

(D)

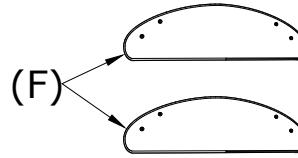

(F)

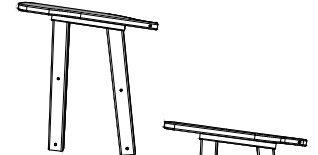

(H)

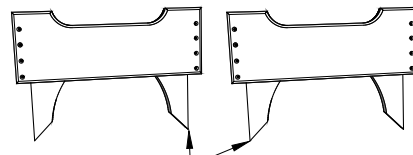

(E)

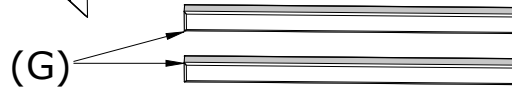

(G)

1. Attach (E) Front Cross Pc. to Glider Base Sides using 7 - 2" Screws per Side, Be sure to match all numbers & or letters.

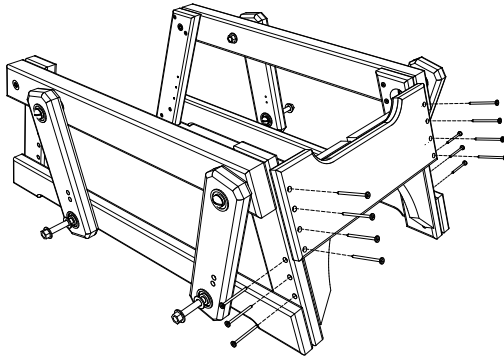

2. Attach (E) Back Cross Pc. to Glider Base Sides using 7 - 2" Screws per side, Be sure to match all numbers & letters.

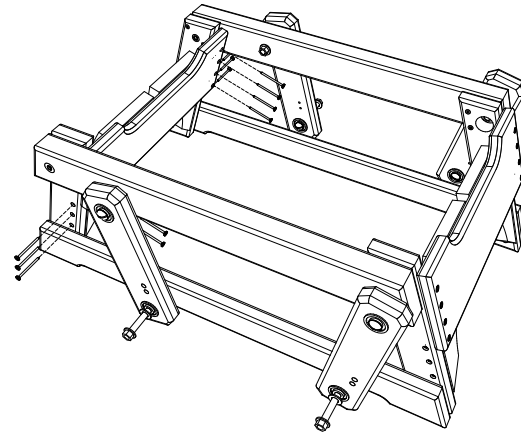

3. Attach (G) Bearing Support Arms to Glider Base using 4 - 2" Screws per side, Be sure to match all numbers & or letters.

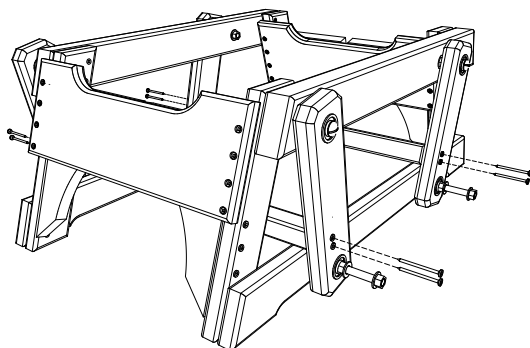



4. Attach (H) Armrest Assemblies to sides of Glider Base using 2 - Washers & 2 Nuts per side, Be sure to match all numbers & or letters.

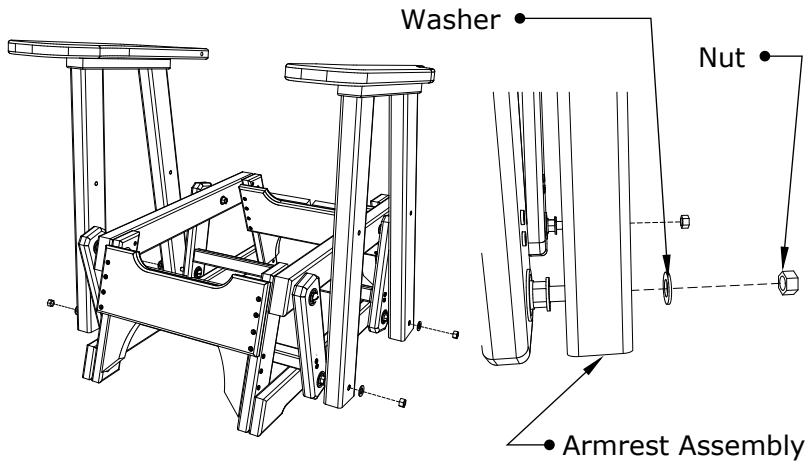

5. Attach (B) Back Assembly to (A) Seat Assembly using 1 - 2" Wafer Bolt in top hole per side, Be sure to match all numbers & or letters. Tighten Wafer Bolts with included Hex Key.

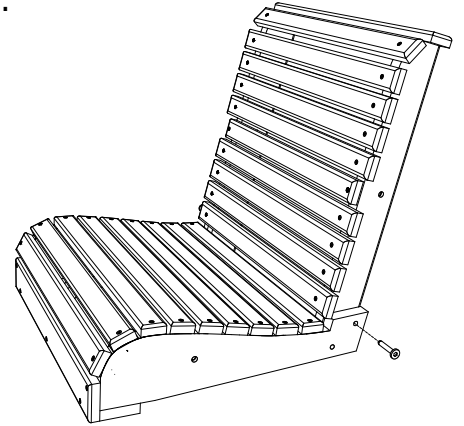

6. Slide Seat & Back Assembly between Armrest's & install 1 - 3 1/2" Wafer Bolt 1 - 2 1/2" Wafer Bolt & 1 - 2" Wafer Bolt per side, Be sure to match all numbers & or letters, Tighten Wafer Bolts with included Hex Key.

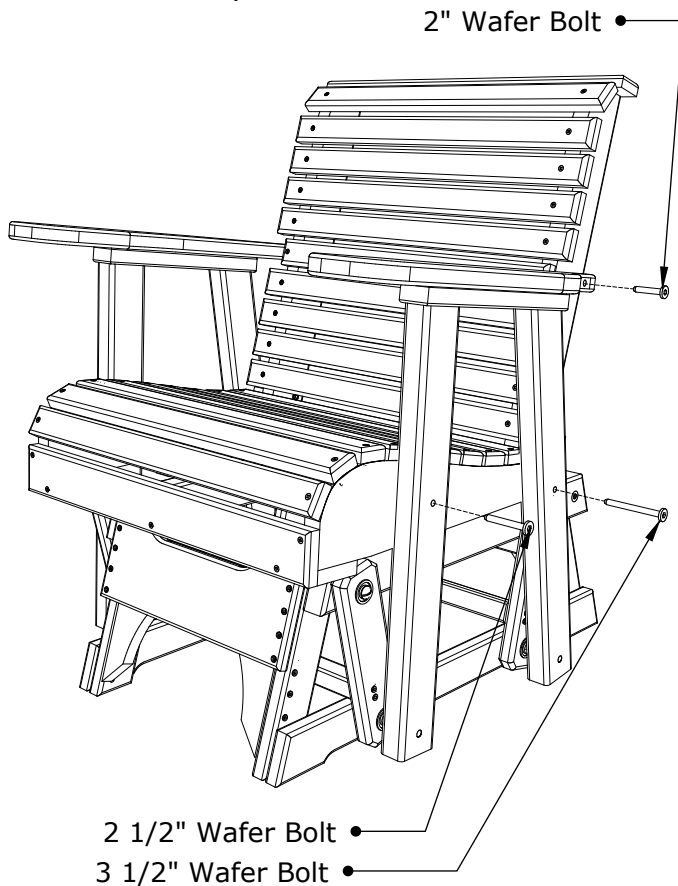

7. Attach Lintels to Armrest Assemblies using 4 - 2" Screws per side, Be sure to match all numbers & or letters.

