

Slim Rear View Camera

INSTRUCTION MANUAL



Vision Tech America, Inc.
1452 E.Valencia Dr, Fullerton, CA 92831
Ph:888-941-3060

* Model VTL275LTJ VTL375LTJ
 VTL405LTJ VTL425LTJ

Table of contents

1. Package -----	3~4
2. Limited time warranty -----	5
3. Care instructions -----	5
4. Key Features -----	5
5. Dimension (inch) & Wiring -----	6~7
6. Specification -----	8
7. Connection instructions -----	9

1. Package

1- 1. VTL275LTJ / VTL375LTJ

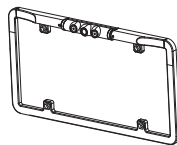

Slim Rear View Camera
1EA



Instruction manual
1EA



M6 Hex bolt
4EA



Spring washer
4EA



Flat washer
4EA



M6 Hex nut
4EA



1.5Ø L-Wrench
1EA



Adaptor cable
1EA



Registration card
1EA



24ft Extension cable
1EA

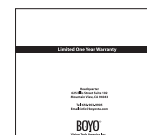

Warranty card
1EA

1. Package

1- 2. VTL405LTJ/VTL425LTJ



Slim Rear View Camera
1EA

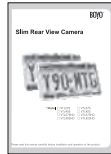

Instruction manual
1EA



M6 Hex bolt
2EA



Spring washer
2EA



Flat washer
2EA



M6 Hex nut
2EA



1.5Ø L-Wrench
1EA



Adaptor cable
1EA



Registration card
1EA



24ft Extension cable
1EA

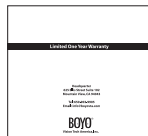

Warranty card
1EA

2.Limited time warranty

Limited time warranty applies only if care instructions are followed regularly. In the event of defective product or workmanship, please return the item to place of purchase.

3. Care instructions

Periodically the mounting frame's appearance may need maintenance. Please take the following action to restore its original brilliant luster. Use non abrasive mild soap detergent and water only to clean.

4. Key Features

- 1/3" CMOS Color Image Sensor
- 960 x 488 Resolution
- 600 TV Lines
- 175 degree Wide Viewing Angle (D)
- Minimum Illumination 0 Lux at F2.0
- LED Lights For Excellent Night Vision
- Reverse/Non Reverse Image(Selectable)
- Trajectory Parking Lines On/Off(Selectable)
- Camera Swivels Up and Down
- IP68 Waterproof Rating
- 24ft Video Extension Cable
- Voltage Tolerance:9VDC-16VDC
- NTSC

* Beautiful design & anti-scratch coating

The camera design is very elegant. Its scratch free coating protects the finish with a very long lasting appearance.

5. Dimension(inch) & Wiring

5- 1. VTL275LTJ / VTL375LTJ

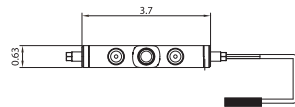

Dimensions in inch

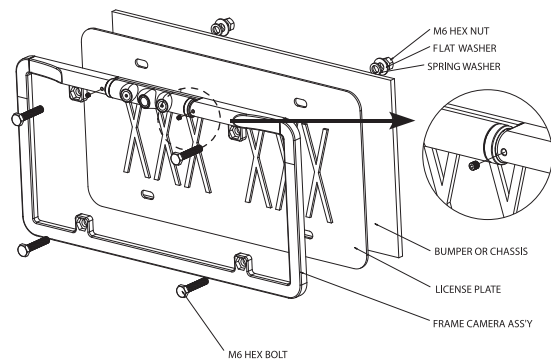
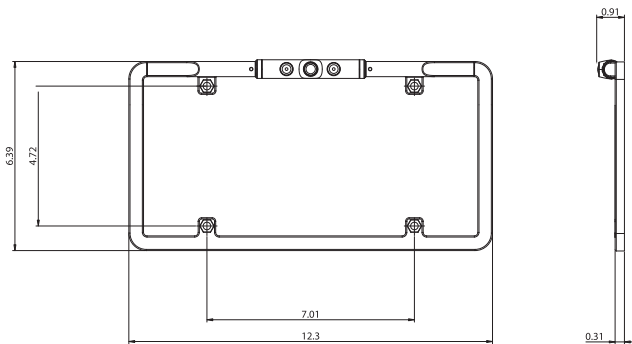

5. Dimension(inch) & Wiring

5- 2. VTL405LTJ / VTL425LTJ

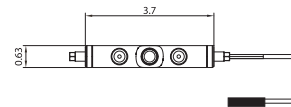

Dimensions in inch

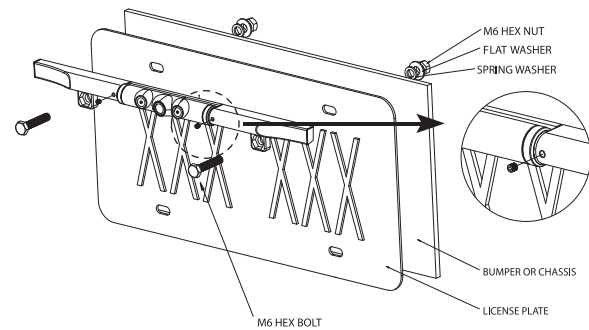
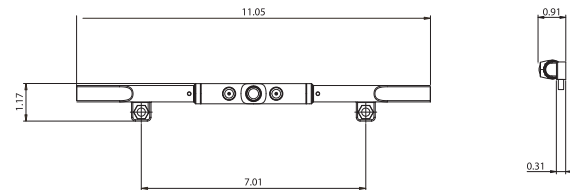

6. Specification

6- 1. VTL275LTJ / VTL375LTJ / VTL405LTJ / VTL425LTJ

Description	Slim Rear View Camera
Effective Pixels	NTSC : 960(H)X488(V)
Horizontal resolution	600 TV Lines
Total number of pixels	NTSC : 460K
Min.Illumination	0 Lus at F2.0
Light	Dual 3W LED lights
Synchronizing system	Internal
Scanning system	Interlaced
Video outp	1Vp-p 75 ohm composite
S/N Ratio	More than 48dB
Electronic Iris	1/50, 1/60-1/100,000sec
Smear effect	0.005%
Gamma correction	r =0.45
White balance	Auto.2100K-9100 K
Gain control	Auto.4dB-30dB
Lens mount	1.56mm Board lens (175 D)
MTBF	80,800 hours
Power source	Car Electric Source DC12V(Tolerance:9VDC 16VDC) Built-in transient impulse protection circuit
Operating current LED OFF	70mA w/regulated power in
Operating Temp.	-4°F~122°F (-20 C ~ +50 C)
Storage Temp.	-40°F~176°F (-40 C ~ +80 C)
Humidity	Up to 90% RH (non-condensing)
Measurement	Camera Size : 3.70(L)X0.63(D) (Camera)
Weight(Approx.g)	VTL275LTJ VTL375LTJ : 454.7g VTL405LTJ VTL425LTJ : 243.7g

7. Connection instructions

7- 1. VTL275LTJ / VTL375LTJ / VTL405LTJ / VTL425LTJ

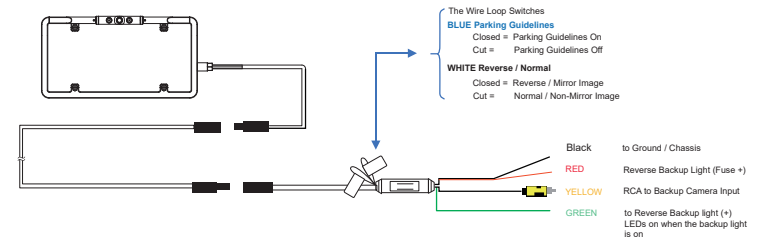
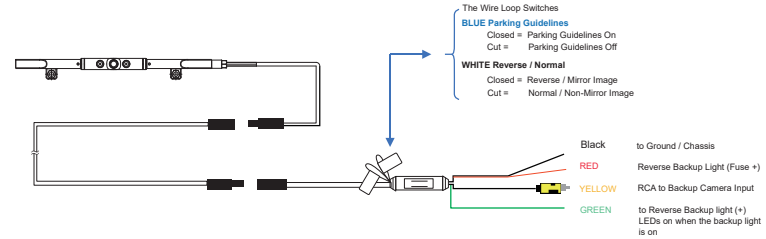

MEMO

MEMO

MEMO

MEMO

MEMO

MEMO
