



# UNDERGROUND CABLE LAYING

MACHINES AND EQUIPMENT





# MACHINES AND EQUIPMENT UNDERGROUND CABLE LAYING

P18.1\_EN





<b>01</b>	<b>HYDRAULIC PULLERS</b>	05	HYDRAULIC PULLERS
<b>02</b>	<b>HYDRAULIC SERVICE WINCHES</b>	27	HYDRAULIC WINCHES
<b>03</b>	<b>REEL-STANDS and TRAILERS</b>	33	REEL-STANDS
<b>04</b>	<b>HYDRAULIC POWER UNITS</b>	45	POWER UNITS
<b>05</b>	<b>REELS and ROPES</b>	49	REELS & ROPES
<b>06</b>	<b>EQUIPMENT</b>	57	EQUIPMENT



01

# HYDRAULIC PULLERS





# F265.P.20

max pull 20 kN



Hydraulic puller fit to pull one rope in laying underground transmission cables and optics fibre cables. One hydraulic circuit allows to continuously vary the speed in both directions by operating one control device.

FEATURES		ENGINE		PULL PERFORMANCES	
Capstans	2 x Ø 200 mm	Feeding	gasoline	Max pull	20 kN
Max nylon rope diam.	12 mm	Power	20,5 hp / 15 kW	Speed at max pull	18 m/min
Max steel rope diam.	8 mm	Cooling	air	Max speed	65 m/min
		Starting	electric with battery 12 V	Pull at max speed	3,5 kN

REEL		DIMENSIONS AND WEIGHT (without rope)	
Type	extractable self-loading	Dimensions	2,30x1,50x1,20 m
Capacity:		Weight	565 kg
Nylon rope Ø 12 mm:	1000 m		
Steel rope Ø 8 mm:	500 m		

## CONFIGURATION

- One pair of multi-grooved steel capstans fit for stringing one steel rope.
- Dynamometer and preselector of max pull force.
- Mechanical metercounter.
- Safety negative hydraulic brake.
- Damped axle with tires and adjustable drawbar for towing at low speed in the job-site.
- Mechanical stabilisers on pull side and jockey wheel on drawbar side.
- Attachments for anchoring and for lifting.
- Heat exchanger to cool the oil in the hydraulic circuit.
- Rope transmission pulley, 360° revolving, fit for pulling underground cables, predisposed to receive the telescopic bar mod. F276 and F279.
- Built-in reel-winder with automatic rope-winder and extractable reel.

## OPTIONAL DEVICES

- 003 Damped axle for towing on road at max speed of 80 km/h, with mechanical brake (homologation excluded).
- 067 Telescopic rod to lay underground cables (art.F277).
- 069.2 Electronic device with USB port, to save the data of the pull.
- 028.3 Air cooled diesel engine with electric starting 19 HP/ 14 kW (it adds 50 kg to the machine weight).
- 069.5 Printer with accessories.

Performances of the machine without optional devices, at sea level and temperature 20°C.  
Dimensions and weights are without optional devices. All data may change without notice. Images and drawings are indicative only.

# F215.P.30

max pull 30 kN



Hydraulic puller fit to pull one rope in laying underground transmission cables and optics fibre cables. One hydraulic circuit allows to continuously vary the speed in both directions by operating one control device.

## FEATURES

Capstans	2 x Ø 200 mm
Max rope diameter	10 mm
Dimensions LxWxH	2,10x1,30x1,30 m
Weight (without rope)	1000 kg

## ENGINE

Feeding	diesel
Power	25,5 hp / 18,8 kW 25,5 hp / 18,8 kW *
Cooling	water
Starting	12 V

## PULL PERFORMANCES

Max pull	30 kN
Speed at max pull	16 m/min
Max speed	80 m/min
Pull at max speed	5 kN

## REEL

Type	extractable
Diameter	600 mm
Capacity of steel rope:	
Ø 8 mm	1000 m
Ø 10 mm	700 m

## CONFIGURATION

- One pair of multi-grooved steel capstans fit for stringing one steel rope.
- Machine control panel equipped with built-in electronic instrument DEG 4.0 featuring a 7" large graphic colour display and a USB port.
- **Maintenance-free load cell reading system.**
- **Electronic instrument by-pass.**
- Safety negative hydraulic brake.
- Chassis with damped axle, tires, overrun brake, manual brake and drawbar for towing on road at max speed of 80 km/h (homologation on request).
- Metallic coverage with doors.
- Four adjustable mechanical stabilisers.
- Attachments for anchoring and for lifting.
- Heat exchanger to cool the oil in the hydraulic circuit.
- Pulley for rope arranged for telescopic rod.
- Built-in reel-winder with automatic rope-winder and extractable reel.

## OPTIONAL DEVICES

- 037 Remote control by cable, with 10 m of cable.
- 038 Radio-control (max distance 100 m).
- 051.3 Motorised rubber caterpillars.
- 038.C Radio-control for caterpillars.
- 067 Telescopic rod to lay underground cables (art.F277).
- 069.5 Printer with accessories.

\* According to the EC directive 97/68/CE with subsequent amendments and additions.

Performances of the machine without optional devices, at sea level and temperature 20°C. Dimensions and weights are without optional devices. All data may change without notice. Images and drawings are indicative only.

# F275.P.50

max pull 50 kN



Hydraulic puller fit to pull one rope in laying underground transmission cables and optics fibre cables. One hydraulic circuit allows to continuously vary the speed in both directions by operating one control device.

FEATURES		ENGINE		PULL PERFORMANCES	
Capstans	2 x Ø 280 mm	Feeding	diesel	Max pull	50 kN
Max rope diameter	14 mm	Power	35 hp / 26 kW	Speed at max pull	13 m/min
Dimensions LxWxH	3,10x1,70x1,75 m		35 hp / 26 kW *	Max speed	60 m/min
Weight (without rope)	1900 kg	Cooling	water	Pull at max speed	13 kN
		Starting	12 V		

REEL	
Type	extractable
Diameter	520 mm
Capacity of steel rope:	
Ø 14 mm	800 m
Ø 12 mm	1000 m
Ø 10 mm	1500 m

ALSO AVAILABLE F275.P.40	
Max pull	40 kN
Speed at max pull	16 m/min
Max speed	60 m/min
Steel rope Ø 12 mm	1000 m
Steel rope Ø 10 mm	1500 m

## CONFIGURATION

- One pair of multi-grooved steel capstans fit for stringing one steel rope.
- Machine control panel equipped with built-in electronic instrument DEG 4.0 featuring a 7" large graphic colour display and a USB port.
- **Maintenance-free load cell reading system.**
- **Electronic instrument by-pass.**
- Safety negative hydraulic brake.
- Chassis with damped axle, tires, overrun brake, manual brake and drawbar for towing on road at max speed of 80 km/h (homologation on request).
- Metallic coverage with doors.
- Four adjustable mechanical stabilisers.
- Attachments for anchoring and for lifting.
- Heat exchanger to cool the oil in the hydraulic circuit.
- Pulley for rope arranged for telescopic rod.
- Built-in reel-winder with automatic rope-winder and extractable reel.

## OPTIONAL DEVICES

- 037 Remote control by cable, with 10 m of cable.
- 038 Radio-control (max distance 100 m).
- 051.3 Motorised rubber caterpillars.
- 038.C Radio-control for caterpillars.
- 067 Telescopic rod to lay underground cables (art.F277).
- 069.5 Printer with accessories.
- 082 Device for pull force setting, which allows to maintain the pre-set even at speed '0' (fit for pipe refurbishing).

\* According to the EC directive 97/68/CE with subsequent amendments and additions.

Performances of the machine without optional devices, at sea level and temperature 20°C. Dimensions and weights are without optional devices. All data may change without notice. Images and drawings are indicative only.

# F285.P.100

max pull 100 kN



Hydraulic puller fit to pull one rope in laying underground transmission cables and optics fibre cables. One hydraulic circuit allows to continuously vary the speed in both directions by operating one control device.

## FEATURES

Capstans	2 x Ø 300 mm
Max rope diameter	16 mm
Dimensions LxWxH	3,10x1,85x1,65 m
Weight (without rope)	2100 kg

## ENGINE

Feeding	diesel
Power	42 hp / 31 kW 56 hp / 42 kW *
Cooling	water
Starting	12 V

## PULL PERFORMANCES

Max pull	100 kN
Speed at max pull	10 m/min 12,5 m/min *
Max speed	50 m/min
Pull at max speed	20 kN 25 kN *

## REEL

Type	extractable
Diameter	850 mm
Capacity of steel rope:	
Ø 16 mm	850 m
Ø 14 mm	1100 m
Ø 12 mm	1500 m

## CONFIGURATION

- One pair of multi-grooved steel capstans fit for stringing one steel rope.
- Machine control panel equipped with built-in electronic instrument DEG 4.0 featuring a 7" large graphic colour display and a USB port.
- **Maintenance-free load cell reading system.**
- **Electronic instrument by-pass.**
- Safety negative hydraulic brake.
- Chassis with damped axle, tires, overrun brake, manual brake and drawbar for towing on road at max speed of 80 km/h (homologation on request).
- Metallic coverage with doors.
- Four adjustable mechanical stabilisers.
- Attachments for anchoring and for lifting.
- Heat exchanger to cool the oil in the hydraulic circuit.
- Pulley for rope arranged for telescopic rod.
- Built-in reel-winder with automatic rope-winder and extractable reel.

## OPTIONAL DEVICES

- 037 Remote control by cable, with 10 m of cable.
- 038 Radio-control (max distance 100 m).
- 051.3 Motorised rubber caterpillars.
- 038.C Radio-control for caterpillars.
- 067.1 Telescopic rod to lay underground operation (art.F276).
- 069.5 Printer with accessories.
- 082 Device for pull force setting, which allows to maintain the pre-set even at speed '0' (fit for pipe refurbishing).

\* According to the EC directive 97/68/CE with subsequent amendments and additions.

Performances of the machine without optional devices, at sea level and temperature 20°C.  
Dimensions and weights are without optional devices. All data may change without notice. Images and drawings are indicative only.

# F280.P.150

max pull 150 kN

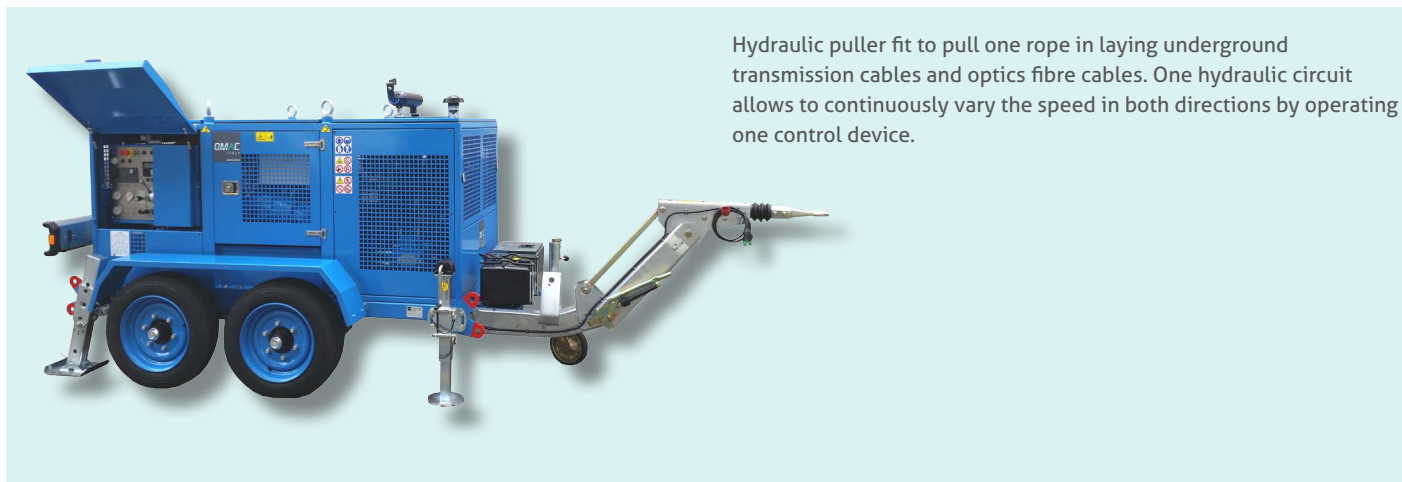

Hydraulic puller fit to pull one rope in laying underground transmission cables and optics fibre cables. One hydraulic circuit allows to continuously vary the speed in both directions by operating one control device.

FEATURES		ENGINE		PULL PERFORMANCES	
Capstans	2 x Ø 350 mm	Feeding	diesel	Max pull	150 kN
Max rope diameter	18 mm	Power	56 hp / 42 kW	Speed at max pull	9 m/min
Dimensions LxWxH	3,50x1,95x1,70 m		75 hp / 55,4 kW *		11 m/min *
Weight (without rope)	3000 kg	Cooling	water	Max speed	30 m/min
		Starting	12 V		30 m/min *
				Pull at max speed	40 kN
					44 kN *

REEL		ALSO AVAILABLE F280.P.100	
Type	extractable	Max pull	100 kN
Diameter	950 mm	Speed at max pull	12 m/min
Capacity of steel rope:			15,5 m/min *
Ø 18 mm	600 m	Max speed	35 m/min
Ø 16 mm	1000 m		38 m/min *
		Steel rope Ø 16 mm	1000 m
		Steel rope Ø 14 mm	1500 m

## CONFIGURATION

- One pair of multi-grooved steel capstans fit for stringing one steel rope.
- Machine control panel equipped with built-in electronic instrument DEG 4.0 featuring a 7" large graphic colour display and a USB port.
- **Maintenance-free load cell reading system.**
- **Electronic instrument by-pass.**
- Safety negative hydraulic brake.
- Chassis with two damped axles (tandem), tires, overrun brake, manual brake and drawbar for towing at low speed in the job-site.
- Metallic coverage with doors.
- Four adjustable mechanical stabilisers.
- Attachments for anchoring and for lifting.
- Heat exchanger to cool the oil in the hydraulic circuit.
- Pulley for rope arranged for telescopic rod.
- Built-in reel-winder with automatic rope-winder and extractable reel.

## OPTIONAL DEVICES

- 006.3 Pneumatic braking system and ABS.
- 028.7 Device to start the diesel engine and the hydraulic circuit at low temperatures (up to -30°C).
- 037 Remote control by cable, with 10 m of cable.
- 038 Radio-control (max distance 100 m).
- 051.3 Motorised rubber caterpillars.
- 038.C Radio-control for caterpillars.
- 067.1 Telescopic rod to lay underground operation (art.F276).
- 069.5 Printer with accessories.
- 082 Device for pull force setting, which allows to maintain the pre-set even at speed '0' (fit for pipe refurbishing).
- 097.1 Device to get a max loadless speed of 45 m/min

\* According to the EC directive 97/68/CE with subsequent amendments and additions.

Performances of the machine without optional devices, at sea level and temperature 20°C.  
Dimensions and weights are without optional devices. All data may change without notice. Images and drawings are indicative only.

# F290.P.200

max pull 200 kN



Hydraulic puller fit to pull one rope in laying underground transmission cables and optics fibre cables. One hydraulic circuit allows to continuously vary the speed in both directions by operating one control device.

## FEATURES

Capstans	2 x Ø 380 mm
Max rope diameter	22 mm
Dimensions LxWxH	3,90x2,20x1,90 m
Weight (without rope)	4200 kg

## ENGINE

Feeding	diesel
Power	85 hp / 63 kW 75 hp / 55,4 kW *
Cooling	water
Starting	12 V

## PULL PERFORMANCES

Max pull	200 kN
Speed at max pull	10 m/min 8 m/min *
Max speed	25 m/min 21 m/min *
Pull at max speed	80 kN

## REEL

Type	extractable
Diameter	1100 mm
Capacity of steel rope:	
Ø 22 mm	1000 m
Ø 18 mm	1500 m

## CONFIGURATION

- One pair of multi-grooved steel capstans fit for stringing one steel rope.
- Machine control panel equipped with built-in electronic instrument DEG 4.0 featuring a 7" large graphic colour display and a USB port.
- **Maintenance-free load cell reading system.**
- **Electronic instrument by-pass.**
- Safety negative hydraulic brake.
- Chassis with two rigid axles (tandem), tires and drawbar for towing at low speed in the job-site.
- Metallic coverage with doors.
- Four adjustable mechanical stabilisers.
- Attachments for anchoring and for lifting.
- Heat exchanger to cool the oil in the hydraulic circuit.
- Pulley for rope arranged for telescopic rod.
- Built-in reel-winder with automatic rope-winder and extractable reel.

## OPTIONAL DEVICES

- 006.3 Pneumatic braking system and ABS.
- 006.4 Arrangement of the chassis for circulation on road (homologation excluded).
- 028.7 Device to start the diesel engine and the hydraulic circuit at low temperatures (up to -30°C).
- 037 Remote control by cable, with 10 m of cable.
- 038 Radio-control (max distance 100 m).
- 051.3 Motorised rubber caterpillars.
- 038.C Radio-control for caterpillars.
- 067.1 Telescopic rod to lay underground operation (art.F276).
- 069.5 Printer with accessories.
- 082 Device for pull force setting, which allows to maintain the pre-set even at speed '0' (fit for pipe refurbishing).
- 097.1 Device to get a max loadless speed of 45 m/min.

\* According to the EC directive 97/68/CE with subsequent amendments and additions.

Performances of the machine without optional devices, at sea level and temperature 20°C.  
Dimensions and weights are without optional devices. All data may change without notice. Images and drawings are indicative only.



# F260.P.600

max pull 600 kN



Hydraulic puller fit to pull one rope in laying underground transmission cables and pipe refurbishing works. One hydraulic circuit allows to continuously vary the speed in both directions by operating one control device.

FEATURES		ENGINE		PULL PERFORMANCES	
Capstans	2 x Ø 580 mm	Feeding	diesel	Max pull	600 kN
Max rope diameter	38 mm	Power	130 hp / 97 kW 148 hp / 110 kW *	Speed at max pull	4,5 m/min 5,5 m/min *
Dimensions LxWxH	5,60x2,50x2,60 m	Cooling	water	Max speed	28 m/min 32 m/min *
Weight (without rope)	10500 kg	Starting	12 V	Pull at max speed	100 kN
REEL		ALSO AVAILABLE F260.P.400			
Type	extractable	Max pull	400 kN		
Capacity of the standard reel:	700 m of steel rope Ø 38 mm	Speed at max pull	7,0 m/min 8,2 m/min *		
Capacity of the optional reel:	1000 m of steel rope Ø 32 mm	Max speed	28 m/min 32 m/min *		

## CONFIGURATION

- One pair of multi-grooved steel capstans fit for stringing one steel rope.
- Machine control panel equipped with built-in electronic instrument DEG 4.0 featuring a 7" large graphic colour display and a USB port.
- **Maintenance-free load cell reading system.**
- **Electronic instrument by-pass.**
- Safety negative hydraulic brake.
- Chassis with two rigid axles (tandem), tires and drawbar for towing at low speed in the job-site.
- Metallic coverage with doors.
- Four adjustable mechanical stabilisers.
- Attachments for anchoring and for lifting.
- Heat exchanger to cool the oil in the hydraulic circuit.
- Pulley for rope arranged for telescopic rod.
- Built-in reel-winder with automatic rope-winder and extractable reel.

## OPTIONAL DEVICES

- 006.3 Pneumatic braking system and ABS.
- 006.4 Arrangement of the chassis for circulation on road (homologation excluded).
- 028.7 Device to start the diesel engine and the hydraulic circuit at low temperatures (up to -30°C).
- 037 Remote control by cable, with 10 m of cable.
- 038 Radio-control (max distance 100 m).
- 051.3 Motorised rubber caterpillars.
- 038.C Radio-control for caterpillars.
- 069.5 Printer with accessories.
- 082 Device for pull force setting, which allows to maintain the pre-set even at speed '0' (fit for pipe refurbishing).

\* According to the EC directive 97/68/CE with subsequent amendments and additions.

Performances of the machine without optional devices, at sea level and temperature 20°C. Dimensions and weights are without optional devices. All data may change without notice. Images and drawings are indicative only.

# F420.100.C

max pull 100 kN



Cable recovery winch designed to remove old or redundant armored telephone cables of up to 80 mm in diameter, mainly for duct reclamation allowing installation of fibre optic cables, but also for recovering old cables for recycling. The winch is driven by a diesel hydraulic power-pack which is totally enclosed within a coverage thereby limiting noise emission. The machine is mounted on damped trailer and it is complete with stabilizing jacks.

FEATURES		ENGINE		PULL PERFORMANCES	
Capstans	350 x Ø 650 mm	Feeding	diesel	Max pull	100 kN
Max cable diameter	80 mm	Power	57 hp / 42 kW	Continuous pull:	
Dimensions LxWxH	4,00x2,20x1,80 m		75 hp / 55,4 kW *	100 kN @ 12 m/min	
Weight (without rope)	2600 kg	Cooling	water	100 kN @ 16,5 m/min *	
		Starting	12 V		

## CONFIGURATION

- Diesel engine, water cooled, electric starting with 12V battery.
- Large-groove steel capstan, with anti-slipping device.
- Control panel with instruments for controlling the hydraulic circuit and the diesel engine.
- Dynamometer for checking pulling values.
- Preselector of maximum wanted pull force to stop the puller in case of overpull.
- Hydrostatic circuit that allows to vary in continue way the speed of the capstan in both sense of rotation operating only one command.
- Hydraulic emergency negative brake auto-operating in central position of command lever or in case of hydraulic breakdown (not fit for lifting).
- Chassis with damped axle, tires, overrun brake, manual brake and drawbar for towing on road at max speed of 80 km/h (homologation on request).
- Metallic coverage with doors.
- Mechanical front and back stabilisers.
- Attachments for anchoring and for lifting.
- Heat exchanger to cool the oil in the hydraulic circuit.
- Back-tension rollers with hydraulic drive.

## OPTIONAL DEVICES

- 005.2 Tandem axle with torsion bar suspensions, overrun braking system and lights (homologation excluded),
- 011 Arrangement of an auxiliary hydraulic circuit, capacity 25 l/min, pressure 200 bar, with 3 outputs for feeding a hydraulic cutter, a water pump and a hydraulic cylinder for the boom.
- 037 Remote control by cable, with 10 m of cable.
- 038 Radio-control (max distance 100 m).
- 044 Mechanical metercounter for measuring the recovered cables length.
- 067 Telescopic rod to lay underground cables (art.F277).
- 068.3 Support with chain-hoist for lifting and lowering the boom.
- 069.5 Printer with accessories.
- 069.2 Electronic device with USB port, to save the pulling data.

\* According to the EC directive 97/68/CE with subsequent amendments and additions.

Performances of the machine without optional devices, at sea level and temperature 20°C.  
Dimensions and weights are without optional devices. All data may change without notice. Images and drawings are indicative only.



# F275.30.P

max pull 30 kN



Hydraulic puller fit to pull one rope in laying underground transmission cables. One hydraulic circuit allows to continuously vary the speed in both directions by operating one control device.

FEATURES		ENGINE		PULL PERFORMANCES	
Capstans	2 x Ø 250 mm	Feeding	diesel	Max pull	30 kN
Capstans grooves	7	Power	35 hp / 26 kW	Speed at max pull	20 m/min
Max rope diameter	13 mm	Cooling	water	Max speed	60 m/min
Max joint diameter	40 mm	Starting	12 V	Pull at max speed	12 kN
Dimensions LxWxH	2,10x1,60x1,60 m				
Weight (without rope)	1105 kg				

## CONFIGURATION

- One pair of multi-grooved steel capstans fit for stringing one steel rope.
- Machine control panel equipped with built-in electronic instrument DEG 4.0 featuring a 7" large graphic colour display and a USB port.
- **Maintenance-free load cell reading system.**
- **Electronic instrument by-pass.**
- Safety negative hydraulic brake.
- Chassis with rigid axle, manual brake and detachable drawbar for towing at low speed in job-site.
- Mechanical front and back stabilisers.
- Attachments for anchoring and for lifting.
- Heat exchanger to cool the oil in the hydraulic circuit.
- Pulley for rope arranged for telescopic rod.
- Reelwinder fit for a 1400-mm-dia reel, with automatic ropewinder.

## OPTIONAL DEVICES

- 007 Chassis with damped axle, overrun brake and drawbar for towing on road (homologation excluded).
- 026 PVC cloth cover.
- 037 Remote control by cable, with 10 m of cable.
- 038 Radio-control (max distance 100 m).
- 051.3 Motorised rubber caterpillars.
- 038.C Radio-control for caterpillars.
- 067 Telescopic rod to lay underground cables (art.F277).
- 069.5 Printer with accessories.
- 047 Hydraulic front stabilisers.

Performances of the machine without optional devices, at sea level and temperature 20°C.  
Dimensions and weights are without optional devices. All data may change without notice. Images and drawings are indicative only.

# F280.40.P

max pull 40 kN



Hydraulic puller fit to pull one rope in laying underground transmission cables. One hydraulic circuit allows to continuously vary the speed in both directions by operating one control device.

FEATURES		ENGINE		PULL PERFORMANCES	
Capstans	2 x Ø 325 mm	Feeding	diesel	Max pull	40 kN
Capstans grooves	7	Power	35 hp / 26 kW	Speed at max pull	18 m/min
Max rope diameter	16 mm	Cooling	water	Max speed	60 m/min
Max joint diameter	45 mm	Starting	12 V	Pull at max speed	12 kN
Dimensions LxWxH	2,15x1,60x1,55 m				
Weight (without rope)	1200 kg				

## CONFIGURATION

- One pair of multi-grooved steel capstans fit for stringing one steel rope.
- Machine control panel equipped with built-in electronic instrument DEG 4.0 featuring a 7" large graphic colour display and a USB port.
- **Maintenance-free load cell reading system.**
- **Electronic instrument by-pass.**
- Safety negative hydraulic brake.
- Chassis with rigid axle, manual brake and detachable drawbar for towing at low speed in the job-site.
- Hydraulic back stabilisers and manual front stabilisers.
- Attachments for anchoring and for lifting.
- Heat exchanger to cool the oil in the hydraulic circuit.
- Pulley for rope arranged for telescopic rod.
- Reelwinder fit for a 1400-mm-dia reel, with automatic ropewinder.

## OPTIONAL DEVICES

- 007 Chassis with damped axle, overrun brake and drawbar for towing on road (homologation excluded).
- 026 PVC cloth cover.
- 037 Remote control by cable, with 10 m of cable.
- 038 Radio-control (max distance 100 m).
- 051.3 Motorised rubber caterpillars.
- 038.C Radio-control for caterpillars.
- 067 Telescopic rod to lay underground cables (art.F277).
- 069.5 Printer with accessories.
- 047 Hydraulic front stabilisers.

Performances of the machine without optional devices, at sea level and temperature 20°C.  
Dimensions and weights are without optional devices. All data may change without notice. Images and drawings are indicative only.

# F230.60.P

max pull 60 kN

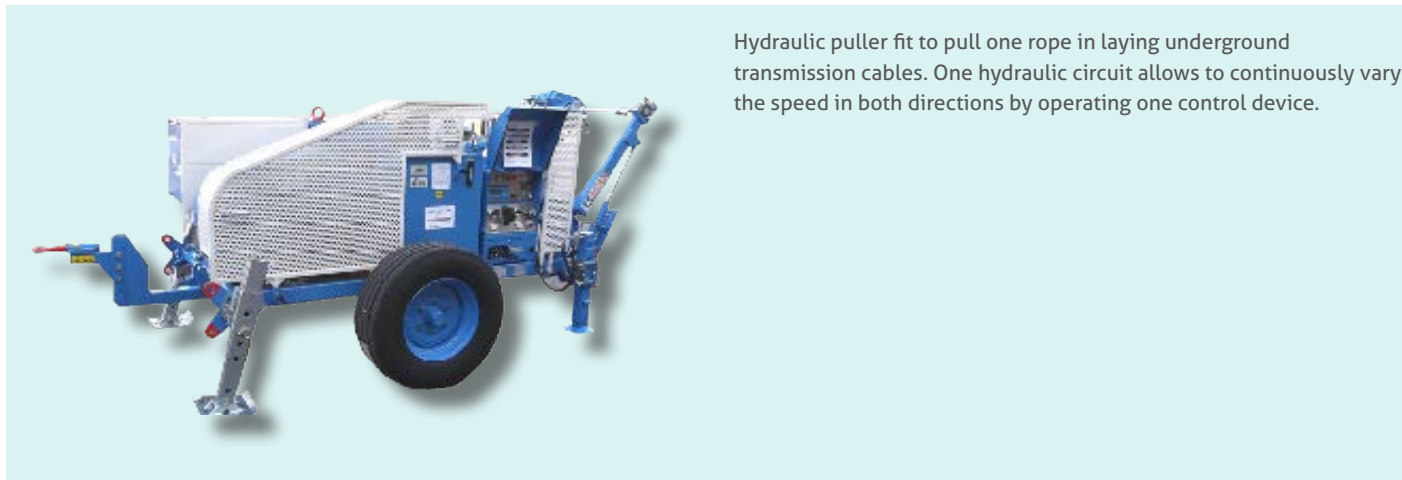

Hydraulic puller fit to pull one rope in laying underground transmission cables. One hydraulic circuit allows to continuously vary the speed in both directions by operating one control device.

FEATURES		ENGINE		PULL PERFORMANCES	
Capstans	2 x Ø 400 mm	Feeding	diesel	Max pull	60 kN
Capstans grooves	8	Power	57 hp / 42 kW	Speed at max pull	20 m/min
Max rope diameter	18 mm		75 hp / 55,4 kW *		23 m/min *
Max joint diameter	50 mm	Cooling	water	Max speed	70 m/min
Dimensions LxWxH	3,20x1,95x2,00 m	Starting	12 V		70 m/min *
Weight (without rope)	2300 kg			Pull at max speed	25 kN

**ALSO AVAILABLE F230.100.P**

Max pull	100 kN
Speed at max pull	12,5 m/min 16,5 m/min *
Max speed	55 m/min 55 m/min *
Pull at max speed	45 kN

**CONFIGURATION**

- One pair of multi-grooved steel capstans fit for stringing one steel rope.
- Machine control panel equipped with built-in electronic instrument DEG 4.0 featuring a 7" large graphic colour display and a USB port.
- **Maintenance-free load cell reading system.**
- **Electronic instrument by-pass.**
- Safety negative hydraulic brake.
- Chassis with rigid axle, manual brake and detachable drawbar for towing at low speed in the job-site.
- Hydraulic back stabilisers and manual front stabilisers.
- Attachments for anchoring and for lifting.
- Heat exchanger to cool the oil in the hydraulic circuit.
- Pulley for rope arranged for telescopic rod.
- Reelwinder fit for a 1600-mm-dia reel, with automatic ropewinder.

**OPTIONAL DEVICES**

- 007 Chassis with damped axle, overrun brake and drawbar for towing on road (homologation excluded).
- 026 PVC cloth cover.
- 028.7 Device to start the diesel engine and the hydraulic circuit at low temperatures (up to -30°C).
- 037 Remote control by cable, with 10 m of cable.
- 038 Radio-control (max distance 100 m).
- 047 Hydraulic front stabilisers.
- 051.3 Motorised rubber caterpillars.
- 038.C Radio-control for caterpillars.
- 069.5 Printer with accessories.
- 067.1 Telescopic rod for underground operations (art.F276).

\* According to the EC directive 97/68/CE with subsequent amendments and additions.

Performances of the machine without optional devices, at sea level and temperature 20°C.  
Dimensions and weights are without optional devices. All data may change without notice. Images and drawings are indicative only.

# F235.130.P

max pull 130 kN



Hydraulic puller fit to pull one rope in laying underground transmission cables. One hydraulic circuit allows to continuously vary the speed in both directions by operating one control device.

FEATURES		ENGINE		PULL PERFORMANCES	
Capstans	2 x Ø 450 mm	Feeding	diesel	Max pull	130 kN
Capstans grooves	9	Power	110 hp / 75 kW	Speed at max pull	17 m/min
Max rope diameter	24 mm		110 hp / 75 kW *		17 m/min *
Max joint diameter	60 mm	Cooling	water	Max speed	55 m/min
Dimensions LxWxH	3,70x2,15x2,10 m	Starting	12 V		55 m/min *
Weight (without rope)	3800 kg			Pull at max speed	40 kN

**ALSO AVAILABLE F235.150.P**

Max pull	150 kN
Speed at max pull	15 m/min
	15 m/min *
Max speed	56 m/min
	56 m/min *
Pull at max speed	40 kN

**CONFIGURATION**

- One pair of multi-grooved steel capstans fit for stringing one steel rope.
- Machine control panel equipped with built-in electronic instrument DEG 4.0 featuring a 7" large graphic colour display and a USB port.
- **Maintenance-free load cell reading system.**
- **Electronic instrument by-pass.**
- Safety negative hydraulic brake.
- Chassis with rigid axle, manual brake and detachable drawbar for towing at low speed in the job-site.
- Hydraulic back stabilisers and manual front stabilisers.
- Attachments for anchoring and for lifting.
- Heat exchanger to cool the oil in the hydraulic circuit.
- Pulley for rope arranged for telescopic rod.
- Reelwinder fit for a 1600-mm-dia reel, with automatic ropewinder.

**OPTIONAL DEVICES**

- 008 Axle with leaf spring suspensions, drawbar, pneumatic braking system, tyres and lights for towing on the road at 60 km/h (homologation excluded).
- 026 PVC cloth cover.
- 028.7 Device to start the diesel engine and the hydraulic circuit at low temperatures (up to -30°C).
- 037 Remote control by cable, with 10 m of cable.
- 038 Radio-control (max distance 100 m).
- 047 Hydraulic front stabilisers.
- 051.3 Motorised rubber caterpillars.
- 038.C Radio-control for caterpillars.
- 069.5 Printer with accessories.
- 084 Bigger reelwinder fit for a 1800-mm-dia reel.
- 067.1 Telescopic rod for underground operations (art.F276).
- 082 Device for pull force setting, which allows to maintain the pre-set force even at speed '0' (fit for pipe refurbishing).

\* According to the EC directive 97/68/CE with subsequent amendments and additions.

Performances of the machine without optional devices, at sea level and temperature 20°C. Dimensions and weights are without optional devices. All data may change without notice. Images and drawings are indicative only.

# F260.200.P

max pull 200 kN

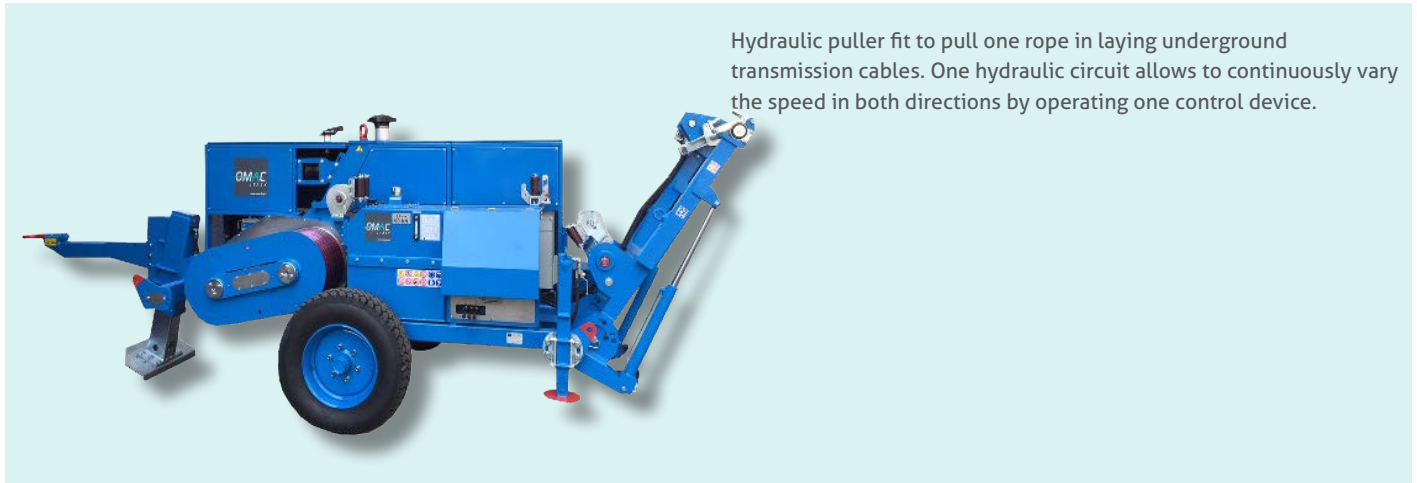

Hydraulic puller fit to pull one rope in laying underground transmission cables. One hydraulic circuit allows to continuously vary the speed in both directions by operating one control device.

FEATURES		ENGINE		PULL PERFORMANCES	
Capstans	2 x Ø 600 mm	Feeding	diesel	Max pull	200 kN
Capstans grooves	10	Power	131 hp / 97 kW 148 hp / 110 kW *	Speed at max pull	12 m/min 16 m/min *
Max rope diameter	24 mm	Cooling	water	Max speed	40 m/min 46 m/min *
Max joint diameter	60 mm	Starting	24 V	Pull at max speed	70 kN
Dimensions LxWxH	3,95x2,40x2,20 m				
Weight (without rope)	6500 kg				

## CONFIGURATION

- One pair of multi-grooved steel capstans fit for stringing one steel rope.
- Machine control panel equipped with built-in electronic instrument DEG 4.0 featuring a 7" large graphic colour display and a USB port.
- **Maintenance-free load cell reading system.**
- **Electronic instrument by-pass.**
- Safety negative hydraulic brake.
- Chassis with rigid axle, manual brake and detachable drawbar for towing at low speed in the job-site.
- Hydraulic back stabilisers and manual front stabilisers.
- Attachments for anchoring and for lifting.
- Heat exchanger to cool the oil in the hydraulic circuit.
- Pulley for rope arranged for telescopic rod.
- Reelwinder fit for a 1600-mm-dia reel, with automatic ropewinder.

## OPTIONAL DEVICES

- 006 Lights and pneumatic brake system for towing on the road at max 30 km/h.
- 008 Axle with leaf spring suspensions, drawbar, pneumatic braking system, tyres and lights for towing on the road at 60 km/h (homologation excluded).
- 026 PVC cloth cover.
- 028.7 Device to start the diesel engine and the hydraulic circuit at low temperatures (up to -30°C).
- 037 Remote control by cable, with 10 m of cable.
- 038 Radio-control (max distance 100 m).
- 047 Hydraulic front stabilisers.
- 051.3 Motorised rubber caterpillars.
- 038.C Radio-control for caterpillars.
- 069.5 Printer with accessories.
- 084 Bigger reelwinder fit for a 1800-mm-dia reel.
- 067.1 Telescopic rod for underground operations (art.F276).
- 082 Device for pull force setting, which allows to maintain the pre-set force even at speed '0' (fit for pipe refurbishing).

\* According to the EC directive 97/68/CE with subsequent amendments and additions.

Performances of the machine without optional devices, at sea level and temperature 20°C.  
Dimensions and weights are without optional devices. All data may change without notice. Images and drawings are indicative only.

# F260.400.P

max pull 400 kN



Hydraulic puller fit to pull one rope in laying underground transmission cables. One hydraulic circuit allows to continuously vary the speed in both directions by operating one control device.

FEATURES		ENGINE		PULL PERFORMANCES	
Capstans	2 x Ø 600 mm	Feeding	diesel	Max pull	400 kN
Capstans grooves	10	Power	176 hp / 130 kW	Speed at max pull	10 m/min
Max rope diameter	32 mm		176 hp / 130 kW *		10 m/min *
Max joint diameter	65 mm	Cooling	water	Max speed	36 m/min
Dimensions LxWxH	4,00x2,45x2,30 m	Starting	24 V		36 m/min *
Weight (without rope)	7500 kg			Pull at max speed	105 kN

## CONFIGURATION

- One pair of multi-grooved steel capstans fit for stringing one steel rope.
- Machine control panel equipped with built-in electronic instrument DEG 4.0 featuring a 7" large graphic colour display and a USB port.
- **Maintenance-free load cell reading system.**
- **Electronic instrument by-pass.**
- Safety negative hydraulic brake.
- Chassis with rigid axle, manual brake and detachable drawbar for towing at low speed in the job-site.
- Hydraulic back stabilisers and manual front stabilisers.
- Attachments for anchoring and for lifting.
- Heat exchanger to cool the oil in the hydraulic circuit.
- Pulley for rope arranged for telescopic rod.
- Reelwinder fit for a 1900-mm-dia reel, with automatic ropewinder.

## OPTIONAL DEVICES

- 006 Lights and pneumatic brake system for towing on the road at max 30 km/h max.
- 008 Axle with leaf spring suspensions, drawbar, pneumatic braking system, tyres and lights for towing on the road at 60 km/h (homologation excluded).
- 005.1 Chassis with 2 damped axles (tandem) air braking system and lights.
- 026 PVC cloth cover.
- 028.7 Device to start the diesel engine and the hydraulic circuit at low temperatures (up to -30°C).
- 037 Remote control by cable, with 10 m of cable.
- 038 Radio-control (max distance 50 m).
- 051.3 Motorised rubber caterpillars.
- 038.C Radio-control for caterpillars.
- 069.5 Printer with accessories.
- 084 Bigger reelwinder fit for a 2200-mm-dia reel (mod.162.220).
- 067.1 Telescopic rod for underground operations (art.F276).
- 082 Device for pull force setting, which allows to maintain the pre-set force even at speed '0' (fit for pipe refurbishing).
- 084.1 Bigger reelwinder fit for a 2200-mm-dia reel (mod.F162.220.1).

\* According to the EC directive 97/68/CE with subsequent amendments and additions.

Performances of the machine without optional devices, at sea level and temperature 20°C. Dimensions and weights are without optional devices. All data may change without notice. Images and drawings are indicative only.



# F224

pushing force 0-8 kN

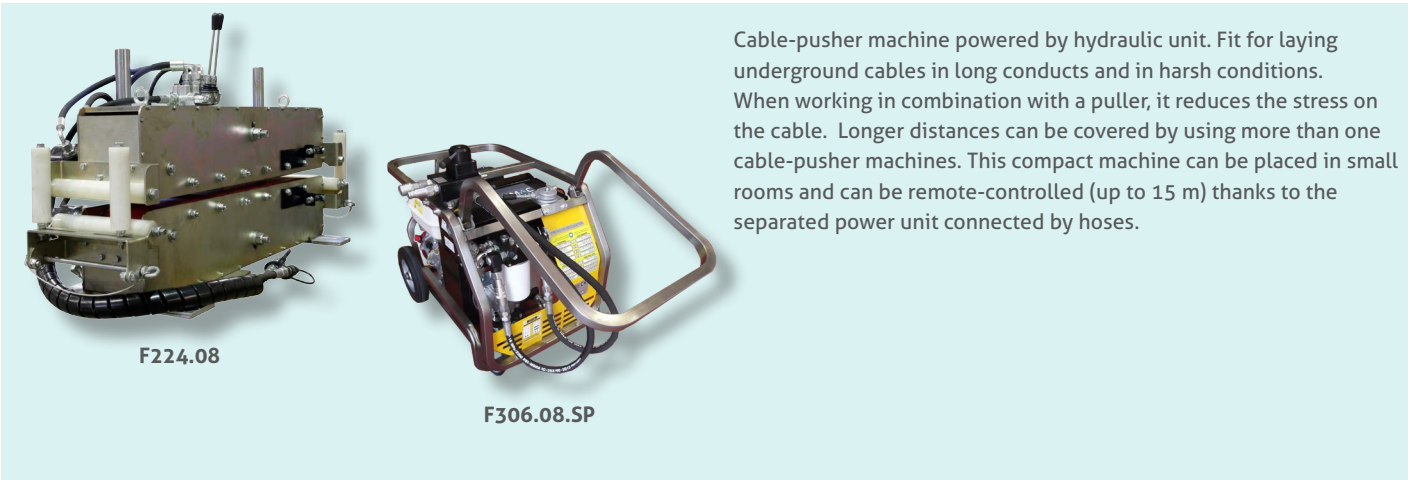

Cable-pusher machine powered by hydraulic unit. Fit for laying underground cables in long conducts and in harsh conditions. When working in combination with a puller, it reduces the stress on the cable. Longer distances can be covered by using more than one cable-pusher machines. This compact machine can be placed in small rooms and can be remote-controlled (up to 15 m) thanks to the separated power unit connected by hoses.

F224.08

F306.08.SP

CABLE-PUSHER UNIT F224.08	
Pushing force	0–8 kN
Pushing speed	0–20 m/min
Cable diameter (min - max)	40-135 mm
Track length	800 mm
Hoses length	5 m
Dimensions LxWxH	1,30x0,35x0,80 m
Weight	200 kg

POWER UNIT F306.08.SP	
Feeding	gasoline
Power	5,88 kW / 8 hp
Cooling	air
Starting	by rope
Max oil flow	20 l/min
Max pressure	150 bar
Dimensions LxWxH	0,75x0,50x0,60 m
Weight	65 kg

### CABLE-PUSHER UNIT

- Cable-pusher unit made of electro-welded steel frame with fittings for anchoring and lifting.
- One pair of tracks with upper tracks operated by hydraulic cylinders.
- Reversible hydraulic motor for operating the tracks. The motor is fitted with quick couplings to connect the power unit through flexible hoses.

### POWER UNIT

- Hydraulic power unit, with gasoline engine and hydraulic circuit, that permits to adjust, by a control valve, the pushing force (0 to max), and the pushing speed. Complete with wheels and handles.
- Flexible hoses 5-m long to connect the cable-pusher unit to the power unit.

### OPTIONAL DEVICES

- 090 Power unit equipped with monophase electric motor 220 V.
- 090.1 Power unit equipped with three-phase electric motor 380 V.
- 028.3 Power unit with air-cooled diesel engine.
- 418 Cable-pusher unit complete with wheels for easy moving.
- 078.1 Flexible hoses 10-m long.
- CAV-1 Machine arrangement suitable for push cable diameters up to Ø150 mm.
- POT-1 Thrust force / traction increased up to 12 kN, speed 0 – 17 m/min.

Performances of the machine without optional devices, at sea level and temperature 20°C. Dimensions and weights are without optional devices. All data may change without notice. Images and drawings are indicative only.

# DEG EVOLUTION 4.0



DEG 4.0 is the evolution of the digital system which has been used on all Omac machines for a long time. The new DEG integrates the latest technologies for monitoring the functions and the performances of machines in the stringing sector. Color graphic 7" touch-screen display, resistive type, intuitive as well as easy in setting-up and browsing through. Configuration, performances reading and recording, display of electronic diesel engine parameters, diagnostics and remote monitoring in one instrument built-in the machine.

## FEATURES

- Large-sized (7") color graphic display, built in the main control panel
- High capacity memory: over 200 km of line.
- High accuracy and reliability by means of the load cell and encoder system.
- Local Wi-Fi network allowing to display the machine status and to download data stored.
- USB port for data downloading.
- Software provided to handle data stored.
- Analog and digital signals for diagnostics.
- CAN port for monitoring electronic diesel engine parameters.



## FUNCTIONS

- Real-time reading and recording pulling force, speed and length of cable/conductor .
- ZOOM mode.
- Max pull force setting.
- Display of working hours.
- Fuel level
- Display of electronic diesel engine parameters.
- Display mirroring on smartphones through local WI-FI.
- Help page on board.
- Remote monitoring system for diagnostics and GPS through data connection (optional device).

## OPTIONAL 069.5

Portable printer c/w connection cable to be plugged to the machine. Fit for printing the recorded data directly in the job-site. Supplied in aluminium case.

## DIAGNOSTICS

- Self-diagnostics upon machine start.
- 5-level maintenance schedules.
- Maintenance alerts.
- Machine diagnostics for problem identification.
- Electronic diesel engines diagnostics.

Dimensions and weights are without optional devices. All data may change without notice. Images and drawings are indicative only.



## REC.1



Compact remote control by cable. Fit for "puller" machines with 1 hydraulic circuit. Pull/release buttons and emergency stop button. 10 m of connection cable.

## REC.2



Remote control by cable. Fit for "puller" machines.

The control is complete with:

- mini joystick for controlling the rotation of the capstans
- speed-adjustment control
- emergency stop button
- 10 m of the connection cable

### OPTIONAL DEVICES

- 01 Dynamometer to read the pulling force, metercounter and speedometer.
- 02 Engine start/stop.
- 03 Engine accelerator.

## RER.1



Remote radio-control fit for "puller" machines. Max operative distance: up to 100 m.

The radio-control is complete with:

- mini joystick for controlling the rotation of the capstans
- speed-adjustment control
- emergency stop button
- back-up cable for connecting the control to the machine in case of emergency.

### OPTIONAL DEVICES

- 01 Dynamometer to read the pulling force, metercounter and speedometer.
- 02 Engine start/stop.
- 03 Engine accelerator.

## 051.3



## FEATURES

- The caterpillar system allows to travel over steeply sloping ground, to turn in tight space.
- The power transmission is granted by the hydraulic circuit of the puller.
- Self-acting negative parking brakes.
- Reversible movement.
- Radio-control.
- Hydraulic controlled share on the pull side, for anchoring the machine.
- Back stabilizers.
- Front and back hooks for towing the machine.

PERFORMANCES	
Moving speed	adjustable
Max speed	2 km/h
Max inclination	80%
Minimum turning radius	4,50 m
Ground loading	0,26 kg/cm <sup>3</sup>

	Dimensioni LxWxH (mm)	Total weight kg
F215.P.30	1,80 x 1,60 x 1,20	1350
F275.P.40 / F275.P.50	2,15 x 1,80 x 1,40	1800
F280.P.100 / F285.P.100	2,86 x 1,85 x 1,87	3600
F290.P.200	3,10 x 2,20 x 2,00	6000
F275.30.P	1,95 x 1,45 x 1,40	1500
F280.40.P	2,20 x 1,60 x 1,60	2300
F230.60.P	3,20 x 1,95 x 2,00	3000

Performances of the machine without optional devices, at sea level and temperature 20°C.  
Dimensions and weights are without optional devices. All data may change without notice. Images and drawings are indicative only.

# F276 - F277 - F278



Telescopic rods for laying underground cables. Mounted on pullers properly arranged, they permit to pull the wire rope inside the manholes. Made with galvanised/painted steel, the rods are easily demountable to facilitate the transport. Telescopic rod for pulling the wire rope inside the pits. Guide system with 360° swivelling pulley.

## F276

Telescopic rod for pulling the wire rope inside the pits. Guide system with 360° swivelling pulley.

## F277

Telescopic rod for pulling the wire rope inside the pits. Guide system with 360° swivelling pulley. Equipped with demountable centerings fit for pipes diameter 80, 100, 120 and 150 mm.

## F278

Telescopic rod for guiding the wire rope inside the pits. Guide system with 360° swivelling pulley. Equipped with rollers device for obtaining a reserve of cable, and demountable centerings fit for pipes diameter 80, 100, 120 and 150 mm.

### OPTIONAL DEVICES

- 201 Supplementary reaction upper arm.
- 202 Reaction arm (90° respect to the pull line).
- 204 Interchangeable, demountable and openable centerings for pipes diam. 80, 100, 120 and 150 mm (standard for mod. F277 and F278).
- 205 Telescopic strut with pulley to space the puller from the manhole.
- 206 Hydraulic control of the rod extension (only for mod. F276 and F277).

	Max pull force	Pit depth (A min/max)	Distance from the pipe (B min/max)	Rod width (C)	Rod weight	Reserve of cable
	daN	mm	mm	mm	kg	m
F276.60	6000 / 10000	500 / 2000	1000 / 1500	120	150	-
F276.100	10000 / 15000	500 / 2000	1400 / 1800	150	200	-
F276.200	20000	1000 / 2000	1500 / 2000	200	350	-
F277.20	2000	0 / 1500	400 / 700	60	55	-
F277.40	3000 / 4000	0 / 1500	400 / 700	80	50	-
F278.20	2000	0 / 1500	1000 / 1400	60	55	2,5
F278.40	3000 / 4000	100 / 2000	1000 / 1500	80	100	3,0

Dimensions and weights are without optional devices. All data may change without notice. Images and drawings are indicative only.



02

# HYDRAULIC SERVICE WINCHES



# F206.10

max pull 10 kN



Hydraulic winch fit to pull one rope in service operations such as setting-ups and adjustment of transmission lines and underground cables laying. Direct pull on the drum. One closed hydraulic circuit allows to continuously vary the speed in both directions by operating one control device.

FEATURES		DRUM		ENGINE	
Dimensions LxWxH	1,65x1,25x1,10 m	Internal diameter	240 mm	Feeding	gasoline
Weight (without rope)	430 kg	External diameter	500 mm	Power	12 hp / 8,8 kW
		Width	480 mm	Cooling	air
		Capacity of rope:		Starting	by rope
		Ø 8 mm	800 m		
		Ø 6 mm	500 m		
PULL PERFORMANCES		ALSO AVAILABLE F206.20			
Max pull	10 kN	Max pull	20 kN		
Speed at max pull	0,9 km/h	Speed at max pull	0,9 km/h		
Max speed	2,4 km/h	Max speed	2,4 km/h		
Pull at max speed	4 kN	Pull at max speed	4,5 kN		
		Power	19 hp / 14 kw		

## CONFIGURATION

- Detachable drum.
- Automatic swinging rope-winder with idle position for manual operation.
- Dynamometer for reading the pull force.
- Freewheeling of the drum.
- Safety hydraulic negative brake.
- Rigid axle with tires and drawbar fit for towing at low speed in the job-site.
- Stabilisers and attachments for anchoring.
- Rope-driver rollers fit for vertical and horizontal pull.

## OPTIONAL DEVICES

- 003 Axle with independent torsion bar suspensions and tires for towing on the road at 60 km/h, with mechanical parking brake.
- 026 PVC cloth cover.
- 028.2 Diesel engine with rope starting.
- 034 Engine electric starting with battery 12 V.
- 035 Preselector of max pull force to stop the engine in case of overpull.
- 056.4 Service steel capstan beside the drum.
- 065 Automatic clamp for rope on side capstan.
- 090 Monophase electric motor 220 V.
- 090.1 Three-phase electric motor.
- 080 Heat exchanger to cool the oil in the hydraulic circuit.
- 127.3 Device for lifting material applications.

Performances of the machine without optional devices, at sea level and temperature 20°C.  
Dimensions and weights are without optional devices. All data may change without notice. Images and drawings are indicative only.

# F207.30

max pull 30 kN



Hydraulic winch fit to pull one rope in service operations such as setting-ups and adjustment of transmission lines and underground cables laying. Direct pull on the drum. One closed hydraulic circuit allows to continuously vary the speed in both directions by operating one control device.

**FEATURES**

Dimensions LxWxH	1,70x1,50x1,35 m
Weight (without rope)	950 kg

**DRUM**

Internal diameter	325 mm
External diameter	540 mm
Width	500 mm
Capacity of rope:	
Ø 12 mm	400 m
Ø 14 mm	350 m

**ENGINE**

Feeding	diesel
Power	35 hp / 26 kW 35 hp / 26 kW *
Cooling	water
Starting	12 V

**PULL PERFORMANCES**

Max pull	30 kN
Speed at max pull	1,5 km/h
Max speed	5 km/h
Pull at max speed	10 kN

**CONFIGURATION**

- Drum equipped with neutral device for unwinding the rope manually.
- Automatic swinging rope-winder with idle position for manual operation.
- Machine control panel with dynamometer and preselector of max pull force.
- Safety hydraulic negative brake.
- Rigid axle with tires and drawbar fit for towing at low speed in the job-site.
- Stabilisers and attachments for anchoring.
- Heat exchanger to cool the oil in the hydraulic circuit.
- Rope-driver rollers fit for vertical and horizontal pull.

**OPTIONAL DEVICES**

- 007 Damped axle, overrun brake and drawbar for towing on the road (homologation excluded).
- 026 PVC cloth cover.
- 027 Metallic coverage with doors.
- 037 Remote control by cable, with 10 m of cable.
- 038 Radio-control for remote control (max distance 100 m).
- 046.3 Rope-presser roller on the drum.
- 058 Service winch with large-groove capstan (Ø 160 or 200 mm) fed by the hydraulic circuit of the puller. Max pulling force 500 kg.
- 064 Device to control the load descent in case of diesel engine breakdown.
- 090.1 Three-phase electric motor.
- 127.3 Device for lifting material applications.

\* According to the EC directive 97/68/CE with subsequent amendments and additions.

Performances of the machine without optional devices, at sea level and temperature 20°C.  
Dimensions and weights are without optional devices. All data may change without notice. Images and drawings are indicative only.



# F210.50

max pull 50 kN



Hydraulic winch fit to pull one rope in service operations such as setting-ups and adjustment of transmission lines and underground cables laying. Direct pull on the drum. One closed hydraulic circuit allows to continuously vary the speed in both directions by operating one control device.

**FEATURES**

Dimensions LxWxH	2,25x1,80x1,50 m
Weight (without rope)	1900 kg

**DRUM**

Internal diameter	400 mm
External diameter	700 mm
Width	700 mm
Capacity of rope:	
Ø 16 mm	450 m
Ø 18 mm	400 m

**ENGINE**

Feeding	diesel
Power	57 hp / 42 kW 57 hp / 42 kW *
Cooling	water
Starting	12 V

**PULL PERFORMANCES**

Max pull	50 kN
Speed at max pull	1,2 km/h
Max speed	5 km/h
Pull at max speed	11 kN

**CONFIGURATION**

- Steel drum.
- Automatic swinging rope-winder with idle position for manual operation.
- Machine control panel with dynamometer and preselector of max pull force.
- Safety hydraulic negative brake.
- Rigid axle with tires and drawbar fit for towing at low speed in the job-site.
- Stabilisers and attachments for anchoring.
- Heat exchanger to cool the oil in the hydraulic circuit.
- Rope-driver rollers fit for vertical and horizontal pull.

**OPTIONAL DEVICES**

- |       |  |
|-------|--|
| 007   | Damped axle, overrun brake and drawbar for towing on the road (homologation excluded).   |
| 026   | PVC cloth cover.   |
| 027   | Metallic coverage with doors.  |
| 037   | Remote control by cable, with 10 m of cable.   |
| 038   | Radio-control for remote control (max distance 100 m).   |
| 046.3 | Rope-presser roller on the drum.   |
| 058   | Service winch with large-groove capstan (Ø 160 or 200 mm) fed by the hydraulic circuit of the puller.<br>Max pulling force 500 kg. |
| 064   | Device to control the load descent in case of diesel engine breakdown.   |
| 127.3 | Device for lifting material applications.  |

\* According to the EC directive 97/68/CE with subsequent amendments and additions.

Performances of the machine without optional devices, at sea level and temperature 20°C.  
Dimensions and weights are without optional devices. All data may change without notice. Images and drawings are indicative only.

# F44.15



Mechanical winch fit to pull one rope while laying underground cables. The motion to the capstans is transmitted through a multiple-disk clutch and a gearbox, operated by means of 2 levers.

## FEATURES

Dimensions LxWxH	1,20x0,80x0,80 m
Weight (without rope)	175 kg

## ENGINE

Feeding	Gasoline
Power	10 hp / 7,3 kW
Cooling	air
Starting	by rope

## PULL PERFORMANCES (capstan Ø160 mm)

### with capstan Ø 160 mm

Forward	18 kN @ 14 m/min
Reverse	15 kN @ 15 m/min

## CONFIGURATION

- Steel capstan dia. 160 mm at bottom groove.
- Gearbox with 1 forward and 1 reverse gears.
- Axle with detachable tires and drawbar fit for moving the machine by hand.
- Protection of capstans.
- The puller is easily decomposable in 4 light-weight groups.
- Rope-driver rollers.

## OPTIONAL DEVICES

- 028.2 Diesel engine with rope starting.
- 034 Engine electric starting with battery 12 V.
- 053 Dynamometer for reading the pull force.
- 091 Electric motor 220/380 V, one or two speeds.
- 101.2 Capstan ø200 at bottom groove (max pull 12 kN).

Performances of the machine without optional devices, at sea level and temperature 20°C.  
Dimensions and weights are without optional devices. All data may change without notice. Images and drawings are indicative only.

03

# REEL-STAND and TRAILERS



# F155

max load 70 to 200 kN



Stands fit for steel or wooden reels, used for lifting a reel and braking it while stringing the conductor/cable. The reel stands, as an option, can be hydraulically driven by a hydraulic power unit. Reel-stands are supplied in pairs.

- No. 1 self-braking disk brake.
- Each stand can be raised or lowered independently by a hydraulic hand pump.
- Mechanical safe-stops mounted on the jack arm.
- Side supports with ball joints.
- Spindle complete with accessories.
- Conical bushes for wooden reels (diameter on demand).
- Welded and painted steel framework with attachments for anchoring.
- Metallic tool box for the accessories.

### OPTIONAL DEVICES

- 423 Additional disk brake (2 brakes in total).
- 410.3 No. 1 or 2 disc brakes with hydraulic clamp controlled by manual pump.
- 408 Hydraulic drive to control the reel rotation, either recovering or releasing the conductor/cable (to be fed by hydraulic power unit).
- 078.1 Set of flexible hoses for feeding the drive unit (available lengths: 7, 10, 15 m).
- 401 Devices fit for steel reel and bushes to centre the reel hole (diameter on demand).
- 419.1 Manual rope-winder, fit to stratify different diameters of rope (max reel width to be confirmed). Available for mod. F155.070 only.
- 419.2 Automatic rope-winder, fit to stratify different diameters of rope (suitable for standard steel reels mod.F162 and F164). Available for mod. F155.150 and F155.200.
- 419.3 Automatic rope-winder, fit to stratify different diameters of rope (max reel width to be confirmed). Available for mod. F155.070 only.

	Reel diameter min-max <sup>(1)</sup>	Reel max width	Spindle diameter	Dimensions of each reel-stand	Weight of the pair of reel-stands <sup>(2)</sup>
	m	m	mm	m (LxW)	kg
F155.070	1,00-2,80	1,50	45	2,10 x 0,50	350
F155.100	1,50-3,20	1,70	55	2,40 x 0,55	540
F155.150	2,00-4,00	3,00	95	3,10 x 0,60	1100
F155.200	2,00-4,00	3,00	95	3,10 x 0,60	1250

(\*)on demand we can supply stands fit for reels with bigger diameter - (2) weight of a pair of standard stands, with no optional devices.

	Max load of the pair of reel-stands	Braking torque with standard brake	Braking torque with 2 brakes opt. 423	Braking torque with brake opt. 410.3	Performances with drive opt. 408		
					Max braking torque	Max recovery torque	Max speed <sup>(3)</sup>
	daN	daN m	daN m	daN m	daN m	km/h	
F155.070	7000	150	300	—	225	180	5
F155.100	10000	230	460	600	280	230	5
F155.150	15000	230	460	1000	312	250	5
F155.200	20000	280	560	1200	375	300	5

(3)powered by hydraulic circuit of a tensioner and puller-tensioner or power unit.

Dimensions and weights are without optional devices. All data may change without notice. Images and drawings are indicative only.

# F155.A

max load 300/500 kN



Stands fit for steel or wooden reels, used for lifting a reel and braking it while stringing the conductor/cable. The reel stands, as an option, can be hydraulically driven by a hydraulic power unit. Reel-stands are supplied in pairs.

- Each stand can be raised or lowered independently by a hydraulic hand pump.
- Side supports with ball joints.
- Spindle complete with accessories.
- Conical bushes for wooden reels and cylindrical bushes for steel reels (diameter on demand).
- Welded and painted steel framework with attachments for anchoring.
- Frame fit for being lifted by crane or fork.
- Metallic tool box for the accessories.
- Ladder and footboard for the operator.
- Dials to close and drag steel and wooden reels, with detachable disk brake.
- Disk brake with manual regulation.

**ALSO AVAILABLE F155.A.400 (40 TON MAX LOAD)**

### OPTIONAL DEVICES

- 402 Additional conical or cylindrical bushes for wooden or steel reels (diameter on demand).
- 408 Hydraulic drive to control the reel rotation, either recovering or releasing the conductor/cable (to be fed by hydraulic power unit).
- 408x2 Double hydraulic drive.
- 078.1 Set of flexible hoses for feeding the drive unit (available lengths: 7, 10, 15 m).
- 409 Steel containers for transporting and stocking the stands (2 containers).
- 410.3 One disc brake with hydraulic clamp controlled by manual pump.
- 419.3 Automatic rope-winder, fit to stratify different diameters of rope (max reel width to be confirmed).
- 423 Additional disk brake (2 brakes in total).
- 458 Reel lifting/lowering system controlled by separate hydraulic circuit. Complete with flexible hoses 10 m long with quick couplings.
- SP2 Base to raise up the stand, fit for reels with diameter up to 6 m.

	Reel diameter min-max	Reel width max <sup>(1)</sup>	Dimensions of each reel-stand	Spindle diameter	Weight of the pair of reel-stands <sup>(2)</sup>
	m	m	m (LxW)	mm	kg
F155.A.300	3,00 – 4,60	2,80	2,80 x 0,70	100 - 140	1600
F155.A.500	3,50 – 4,80	3,60	3,10 x 0,90	120 - 160	2400

<sup>(1)</sup> to be agreed - <sup>(2)</sup> weight of a pair of standard reel-stands, without optional devices.

	Max load of the pair of reel-stands	Braking torque with standard brake	Braking torque with 2 brakes opt. 423	Performances with drive opt. 408		
				Max braking torque opt.408	Max recovering torque opt.408	Max speed <sup>(3)</sup>
	daN	daN m	daN m	daN m	daN m	m/min
F155.A.300	30000	150	300	600	500	50
F155.A.500	50000	230	460	1600	1400	15

<sup>(3)</sup> powered by hydraulic power unit mod. F306.21.CC

Dimensions and weights are without optional devices. All data may change without notice. Images and drawings are indicative only.

# F155.C

max load 300/900 kN

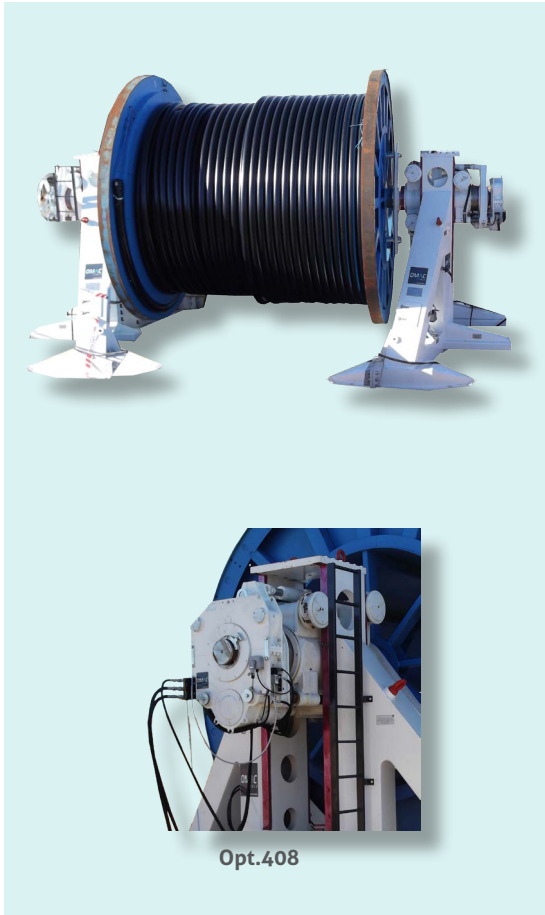

Tail-stock stands fit for steel reels, used for lifting a reel and braking it while stringing the conductor/cable. The reel stands, as an option, can be hydraulically driven by a hydraulic power unit. Reel-stands are supplied in pairs.

- Each stand can be raised or lowered independently by a hydraulic hand pump.
- Tail-stocks for sustaining the reel.
- Steel frame with detachable feet for reduced overall dimensions.
- Frame fit for being lifted by crane or fork.
- Pair of bushes for centring the reel hole (reel hole diameter to be specified).
- Disk brake with manual regulation (optional: two disk brakes – opt.423).

**OPTIONAL DEVICES**

- 402 Additional cylindrical bushes for steel reels (diameter on demand).
- 408 Hydraulic drive to control the reel rotation, either recovering or releasing the conductor (to be fed by hydraulic power unit), weight 380kg.
- 408x2 Double hydraulic motorization.
- 078 Set of flexible hoses (10 m long) for feeding the drive unit by separate hydraulic power unit.
- 410.3 One or two disc brakes with hydraulic control and manual pump.
- 423 Additional mechanical manual disk brake (2 brakes in total).
- 458 Reel lifting/lowering system controlled by separate hydraulic circuit. Complete with flexible hoses 10 m long with quick couplings.
- 464 Sliding tailstock controlled by hydraulic cylinder with hand pumps (the weight increases by 650 kg).

REEL-STANDS

	Max load of the pair of reel-stands	Reel diameter min-max (*)	Reel width max	Dimensions of each reel-stand	Tail-stocks diameter	Weight of each stand (?)
	daN	m	m	m (LxWxH)	mm	kg
F155.C.300	30.000	3,00 – 4,60	Infinite	3,00 x 1,50 x 2,70	120	3900
F155.C.500	50.000	3,00 – 5,00	Infinite	4,05 x 1,80 x 3,20	150	4500
F155.C.700	70.000	3,00 – 5,00	Infinite	4,05 x 1,80 x 3,20	150	4600
F155.C.900	90.000	3,60 – 5,20	Infinite	4,70 x 2,40 x 3,40	250	9500

(\*)on demand we can supply stands fit for reels with bigger diameter - (?) weight with no optional devices.

	Braking torque		Performances with drive opt. 408 (3)			
	with 1 brake (standard)	with 2 brakes (opt.423)	Braking		Recovering	
			Max torque	Speed	Max torque	Speed
	daN m	daN m	daN m	m/min	daN m	m/min
F155.C.300	200	400	700	25	600	15
F155.C.500	200	400	1600	25	1400	15
F155.C.700	200	400	1600	25	1400	15
F155.C.900	350	700	3000	25	2500	12

(3)powered by hydraulic unit mod. F306.21.CC

Dimensions and weights are without optional devices. All data may change without notice. Images and drawings are indicative only.



# C141

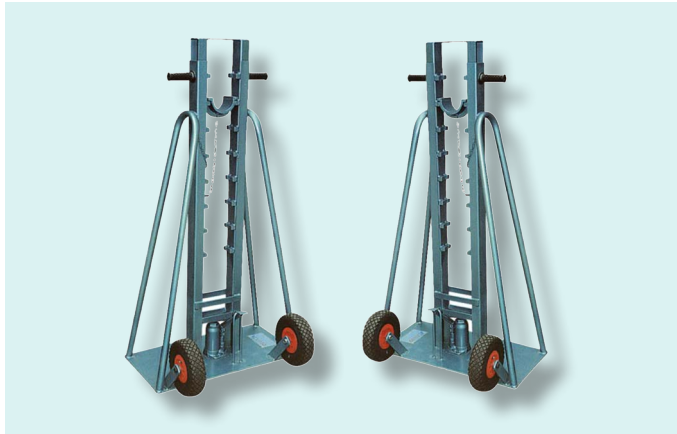

Reel-stand with hydraulic lifting system controlled by pedal. The stands are supplied in pairs.

	Max load	Reel diameter	Base	Shaft Ø	Weight
	kg	mm	mm	mm	kg
<b>C141.18</b>	1800	700-2000	42x30	60	24
<b>C141.30</b>	3000	800-2500	54x34	75	55
<b>C141.50</b>	5000	1000-3200	80x40	75	88
<b>C141.100</b>	10000	1350-3600	100x50	90	100

# C141.A



Shaft made of galvanized steel tubular with ball bearings.

	Diameter	Length	Max load	Weight
	mm	mm	kg	kg
<b>C141.A60.15</b>	60	1500	1800	18,0
<b>C141.A75.15</b>	75	1500	3000/5000	14,6
<b>C141.A75.18</b>	75	1800	3000/5000	18,5
<b>C141.A90.15</b>	75	2050	3000/5000	19,6
<b>C141.A90.18</b>	90	1500	10000	18,5
<b>C141.A90.20</b>	90	1800	10000	22,2

# C141.B



Galvanized steel collar.

	for spindle Ø	Weight
	mm	kg
<b>C141.B60</b>	60	1,2
<b>C141.B75</b>	75	1,5
<b>C141.B90</b>	90	1,7

# C141.C

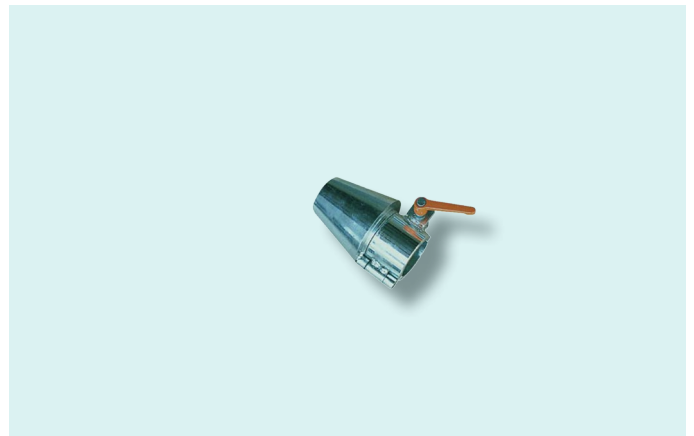

Centering cone.

	for spindle Ø	for reel hole Ø	Weight
	mm	mm	kg
<b>C141.C60</b>	60	65-11	3
<b>C141.C75</b>	75	85-130	7
<b>C141.C90</b>	90	110-150	8,5

Dimensions and weights are without optional devices. All data may change without notice. Images and drawings are indicative only.



# F10.50



Trailer fit to transport and unwind reels of cable weighting up to 4000 kg.

REEL-STANDS

### TRAILER CHARACTERISTICS

Dimensions LxWxH	6,40x3,30x2,60 m
Total weight with drum	5000 kg
Drum max diameter	2800 mm
Drum max width	1500 mm

### Performances with optional drive (opt.408.4 or 408.5)

Pulling force	0 - 9 kN
Pulling speed	0 - 60 m/min

### ALSO AVAILABLE TRAILERS WITH DIFFERENT CAPACITY

#### CONFIGURATION

- Framework made of 3 steel sections.
- Spindle rotating on ball joints, with arm for close and drag the reel, and collars for wooden reel.
- Safe mechanical locking in working position.
- Mechanical locking of the spindle rotation for safe transport.
- Single rigid axle and rigid towing assembly.
- Towing speed 40 Km/h.
- Front support.
- No brakes and No lights.

#### OPTIONAL DEVICES

- 006.1 12V light system.
- 006.6 Hand parking brake for trailer.
- 425 Mechanical back supports.
- 438 Hydraulic reel lift with hand pump.
- 007-A Damped single axle, towing speed 60 km/h. Complete with ABS system.
- 007-B Dumped single axle, towing speed 80 km/h. Complete with ABS system and pneumatic suspensions.
- 029.2 Electric start of the diesel/gasoline engine, with battery.
- 401 Devices fit for using steel reels with the reel-elevator.
- 408.4 Hydraulic drive with quick connections for controlling the reel rotation both recovering and releasing cables, complete with power unit and gasoline engine.
- 408.5 Hydraulic drive with quick connections for controlling the reel rotation both recovering and releasing cables, complete with power unit and diesel engine.
- 410.1 Disk brake with manual regulation of the braking to keep under control the unwinding.

Dimensions and weights are without optional devices. All data may change without notice. Images and drawings are indicative only.



# F10.100



Trailer fit to transport and unwind reels of cable weighting up to 8000 kg.

## TRAILER CHARACTERISTICS

Dimensions LxWxH	7,30x3,50x2,70 m
Total weight with drum	10000 kg
Drum max diameter	3000 mm
Drum max width	1600 mm

## Performances with optional drive (opt.408.4 or 408.5)

Pulling force	0 - 9 kN
Pulling speed	0 - 60 m/min

## ALSO AVAILABLE TRAILERS WITH DIFFERENT CAPACITY

### CONFIGURATION

- Framework made of 3 steel sections.
- Spindle rotating on ball joints, with arm for close and drag the reel and collars for wooden reels.
- Safe mechanical locking in working position.
- Mechanical locking of the spindle rotation for safe transport.
- Single rigid axle and rigid towing assembly.
- Towing speed 40 Km/h.
- Front support.
- No brakes and no lights.

### OPTIONAL DEVICES

- 006.1 12V light system.
- 006.6 Hand parking brake for trailer.
- 425 Mechanical back supports.
- 438 Hydraulic reel lift with hand pump.
- 005.1 Damped tandem axle, towing speed 60 km/h. Complete with ABS system.
- 005.3 Damped tandem axle, towing speed 80 km/h. Complete with ABS system and Pneumatic suspensions.
- 029.2 Electric start of the diesel/gasoline engine, with battery.
- 401 Devices fit for using steel reels with the reel-elevator.
- 408.4 Hydraulic drive with quick connections for controlling the reel rotation both recovering and releasing cables, complete with power unit and gasoline engine.
- 408.5 Hydraulic drive with quick connections for controlling the reel rotation both recovering and releasing cables, complete with power unit and diesel engine.
- 410.1 Disk brake with manual regulation of the braking to keep under control the unwinding.

Dimensions and weights are without optional devices. All data may change without notice. Images and drawings are indicative only.

# F10.120



Trailer fit to transport and unwind reels of cable weighting up to 10000 kg.

REEL-STANDS

### TRAILER CHARACTERISTICS

Dimensions LxWxH	7,30x3,50x2,70 m
Total weight with drum	12000 kg
Drum max diameter	3000 mm
Drum max width	1600 mm

### Performances with optional drive (opt.408.4 or 408.5)

Pulling force	0 - 9 kN
Pulling speed	0 - 60 m/min

### ALSO AVAILABLE TRAILERS WITH DIFFERENT CAPACITY

#### CONFIGURATION

- Framework made of 3 steel sections.
- Spindle rotating on ball joints, with arm for close and drag the reel, and collars for wooden reel.
- Safe mechanical locking in working position.
- Mechanical locking of the spindle rotation for safe transport.
- Single rigid axle and rigid towing assembly.
- Towing speed 40 Km/h.
- Front support.
- No brakes and No lights.

#### OPTIONAL DEVICES

- 006.1 12V light system.
- 006.6 Hand parking brake for trailer.
- 425 Mechanical back supports.
- 438 Hydraulic reel lift with hand pump.
- 005.1 Damped tandem axle, towing speed 60 km/h. Complete with ABS system.
- 005.3 Damped tandem axle, towing speed 80 km/h. Complete with ABS system and Pneumatic suspensions.
- 029.2 Electric start of the diesel/gasoline engine, with battery.
- 401 Devices fit for using steel reels with the reel-elevator.
- 408.4 Hydraulic drive with quick connections for controlling the reel rotation both recovering and releasing cables, complete with power unit and gasoline engine.
- 408.5 Hydraulic drive with quick connections for controlling the reel rotation both recovering and releasing cables, complete with power unit and diesel engine.
- 410.1 Disk brake with manual regulation of the braking to keep under control the unwinding.

Dimensions and weights are without optional devices. All data may change without notice. Images and drawings are indicative only.

# F10.500



Trailer fit to transport and unwind reels of cable weighting up to 50000 kg.

## REEL CHARACTERISTICS

Drum max diameter	5000 mm
Drum max width	2700 mm
Drum max weight	50000 kg
Total weight of the trailer with reel	59000 kg

## Performances with optional drive (opt.408.4 or 447)

Max braking torque	750 daN
Max recovering torque	500 daN

## TRAILER CHARACTERISTICS

Dimensions LxWxH	8,80x4,20x3,00 m
Weight	9000 kg

## CONFIGURATION

- Framework made of welded steel sections.
- Hydraulic cylinders operated by hand pump for lifting the reel (opt.447, drum lifting from hydraulic power pack)
- Spindle rotating on ball bearings, with arm for close and drag the reel.
- Safe mechanical locking in working position.
- Mechanical locking of the reel rotation for safe transport.
- No. 6 semi-axle shafts, tires and drawbar for towing at low speed in the workplace max 15 km/h
- Mechanical stabiliser on towing side.
- Manual parking brake of the truck.
- Disc brake with manual regulation of the braking to keep under control the unwinding, complete with dragger for reels (max braking torque 150 daNm).

## OPTIONAL DEVICES

- 006 Lights and braking system of the trailer.
- 008 Suspensions on semi-axles, and pneumatic braking system, tyres and lights for towing on the road at 20km/h (homologation excluded).
- 401 Devices fit for using steel reels with the reel-elevator (reel hole diameter to be specified).
- 447 Diesel engine with control pump of the hydraulic circuit for lifting the reel.
- 408.4 Hydraulic drive with quick connections for controlling the reel rotation both recovering and releasing cables, complete with power unit and gasoline engine.
- 459 Device that allows to tighten the trailer to a width "B" on the trailer min 2.5 m.
- 460 Trailer adjustments fit for transporting drums with max width 3500 mm.
- 461 Tail-stocks system for supporting the drum (instead of the shaft system).
- 462 Swivel and adjustable towing bar to facilitate the trailer handling in limited spaces.
- 463 Steerable towing assembly complete with axle, wheels and towing arm on fifth wheel.

Dimensions and weights are without optional devices. All data may change without notice. Images and drawings are indicative only.





04

# HYDRAULIC POWER UNITS





# F306.09.CA



Hydraulic power unit with one hydraulic circuit (open type) fit to feed various equipment.

ENGINE		PERFORMANCES	
Feeding	gasoline	Working pressure	150 bar
Power	9 hp / 6,6 kW	Capacity	20 L/min
Revolutions per minute	2800 rpm	Noise level	80 dbA
Cooling system	air		
Starting	by rope		
Dimensions LxWxH	0,70x0,50x0,60 m		
Weight	68 kg		

## CONFIGURATION

- Control lever.
- Manometer to control the pressure.
- Quick couplings to connect hydraulic hoses.
- Hydraulic oil tank.
- Wheels with tow handle.
- Protective frame.

## OPTIONAL DEVICES

- 028 Air cooled diesel engine.
- 034 Engine electric starting with battery.
- 078 Set of flexible hoses (10m long) with quick couplings.
- 080 Oil cooling system (needed for operating in hot environments).
- 090 Monophase electric motor 220 V, 3kW.
- 090.1 Three-phase electric motor 380 V, 3 kW.

Performances of the machine without optional devices, at sea level and temperature 20°C.  
Dimensions and weights are without optional devices. All data may change without notice. Images and drawings are indicative only.

# F306.18.CC



Hydraulic power unit with one hydraulic circuit (closed type) fit to feed reel-stands drive.

## ENGINE

Feeding	gasoline
Power	18 hp / 13,2 kW
Cooling system	air
Starting	12 V
Dimensions LxWxH	1,20x0,90x0,95 m
Weight	475 kg

## PERFORMANCES

Fit for motorizations of reel-stands with capacity	120-500 kN
Pump delivery (variable)	0-28 cm <sup>3</sup>
Working pressure	210 bar

## ALSO AVAILABLE F306.21.CC

feeding	diesel
power	21 hp / 15,4 kW
starting	12 V
cooling system	air
fit for motorizations of reel-stands with capacity	300-500 kN
pump delivery (variable)	0-40 cm <sup>3</sup>
working pressure	210 bar

## CONFIGURATION

- Control panel with joystick for puller use, dynamometer and preselector of max pull force, valve to adjust the tension force and control for unlocking the negative brake.
- Group of quick couplings to connect the hydraulic hoses.
- Rigid axle, tires, hand brake and drawbar for towing at low speed in the subsite.
- Metallic coverage with side doors.
- Oil cooling system.

## OPTIONAL DEVICES

- 011 Auxiliary hydraulic circuit for additional equipment (like hydraulic cylinders).
- 028 Air-cooled diesel engine.
- 028.1 Water-cooled diesel engine.
- 078.3 Set of flexible hoses (10 m long) with quick-joints to feed additional equipment (with opt. 011).

Performances of the machine without optional devices, at sea level and temperature 20°C.  
Dimensions and weights are without optional devices. All data may change without notice. Images and drawings are indicative only.

05

# REELS and ROPES



# 21.12



Anti-twisting galvanized steel rope specifically designed for stringing operations. Made up of 12 braided strands. High resistant to break, antitwisting, flexible, safe and easy to handle. The linear contact between the braided strands grants a low stress on the rope. Supplied wound up on steel or wooden reels.

	Nominal diameter	Breaking load	Weight	Standard Lengths (*)
	mm	kN	kg	m
21.12.08	8	44	0,22	1000
21.12.10	10	72	0,35	1000
21.12.13	13	105	0,55	1000
21.12.16	16	163	0,80	1000
21.12.18	18	235	1,07	1000
21.12.20	20	268	1,24	1000
21.12.22	22	330	1,56	900
21.12.24	24	380	1,80	800
21.12.28	28	480	2,80	600

(\*) other lengths on request

### HIGH RESISTANCE (18 strands)

	Nominal diameter	Breaking load	Weight	Standard Lengths (*)
	mm	kN	kg	m
21.18.22	22	402	1,86	900
21.18.24	24	490	2,34	800
21.18.30	30	720	3,25	500

(\*) other lengths on request

### OPTIONAL DEVICES

- 146.2 Spliced eyes at both ends
- 146.3 Clamped eyes at both ends

Dimensions and weights are without optional devices. All data may change without notice. Images and drawings are indicative only.

## 22...1



Pilot rope made of an external polyester mesh stocking and a hi-tenacity nylon core. Double torsion. Highly resistant to wear and UV rays. white colour. Supplied wound up on wooden reels or in coils.

### OPTIONAL DEVICES

- Clamped eyes with metallic collars at the ends (note: the clamped eyes have breaking load 30-35% lower than the rope).
- Sewn eyes (note: available up to Ø18 mm. The breaking load of the clamped eyes is the same as the breaking load of the rope).

	Nominal diameter	Elongation under tension		Breaking load	Weight	Standard Lengths (*)				
	mm	at 10 % BL <sup>(1)</sup>	at 30 % BL <sup>(2)</sup>	daN	kg/m	m				
22.06.1	6	4%	7,5%	750	0,027	500	1000	1500	2000	3000
22.08.1	8	4%	7,5%	1.200	0,045	500	1000	1500	2000	3000
22.10.1	10	4%	7,5%	2.000	0,073	500	1000	1500	2000	3000
22.12.1	12	4%	7,5%	3.500	0,115	500	1000	1500	2000	3000
22.14.1	14	4%	7,5%	4.300	0,142	500	1000	1500	2000	
22.16.1	16	4%	7,5%	5.000	0,195	500	1000	1500	2000	
22.18.1	18	4%	7,5%	5.800	0,240	500	1000	1500		
22.20.1	20	4%	7,5%	6.500	0,295	500	1000	1500		
22.22.1	22	4%	7,5%	8.300	0,350	500	900			
22.24.1	24	4%	7,5%	9.500	0,410	500	800			

(<sup>1</sup>) elongation rate at 10% of breaking load (<sup>2</sup>) elongation rate at 30% of breaking load

## 22...2

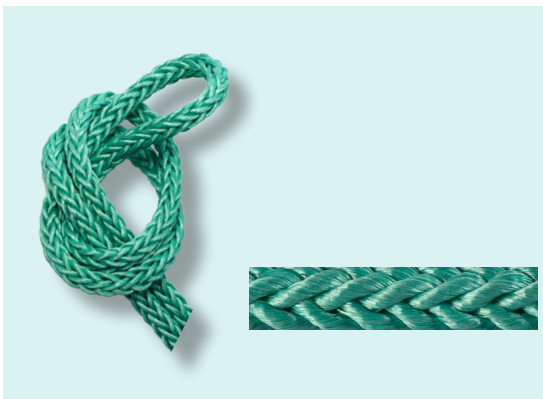

Pilot rope made of polypropylene and polyester hi-tenacity 12-fuses mesh. Light-weight, waterproof and UV resistant. Easy to splice without any special tool. Green colour. Supplied wound up on wooden reels or in coils.

### OPTIONAL DEVICES

- Hand-spliced ends.

	Nominal diameter	Elongation under tension	Breaking load	Weight	Standard Lengths (*)				
	mm	at 50 % BL <sup>(1)</sup>	daN	kg/m	m				
22.10.2	10	5%	1.500	0,040	1000				
22.12.2	12	5%	2.300	0,060	1000				
22.14.2	14	5%	2.800	0,075	1000				
22.16.2	16	5%	3.300	0,088	1000				
22.18.2	18	5%	4.500	0,120	1000				
22.20.2	20	5%	5.500	0,150	1000				
22.22.2	22	5%	6.200	0,165	800				
22.24.2	24	5%	8.500	0,240	800				

Dimensions and weights are without optional devices. All data may change without notice. Images and drawings are indicative only.

## 23...P

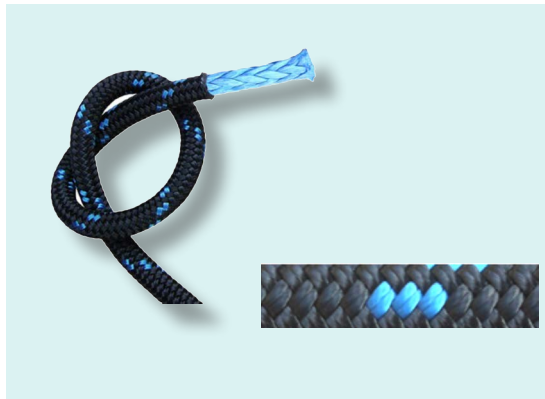

Rope with Dyneema-core and polyester covering. Supplied wound up on wooden reels or in coils.

### OPTIONAL DEVICES

- Clamped eyes with metallic collars at the ends (note: the clamped eyes have breaking load 30-35% lower than the rope).
- Hand-spliced eyes.
- Head stocking-grip with eyes.
- Steel reel Ø 1100, 1400 or 1600 mm.

	Nominal diameter	Elongation under tension (*)	Breaking load	Weight	Standard Lengths (*)
	mm	%	daN	kg/m	m
23.06.P	6	3%	3.100	0,050	500 <b>1000</b> 1500 2000 3000
23.08.P	8	3%	5.480	0,064	500 <b>1000</b> 1500 2000 3000
23.10.P	10	3%	8.210	0,078	500 <b>1000</b> 1500 2000 3000
23.12.P	12	3%	11.860	0,120	500 <b>1000</b> 1500 2000
23.14.P	14	3%	16.430	0,139	500 <b>1000</b> 1500 2000
23.16.P	16	3%	20.990	0,200	500 <b>1000</b>

(\*) elongation rate at 8% of breaking load

## 23...D



High resistance dyneema rope. Light-weight and wear resistant. Supplied wound up on wooden reels or in coils.

### OPTIONAL DEVICES

- Clamped eyes with metallic collars at the ends (note: the clamped eyes have breaking load 30-35% lower than the rope).
- Hand-spliced eyes.
- Head stocking-grip with eyes.
- Steel reel Ø 1100, 1400 or 1600 mm.

	Nominal diameter	Elongation under tension	Breaking load	Weight	Standard Lengths (*)
	mm	at 2 %	daN	kg/m	m
23.06.D	6	3%	4.000	0,02	500 1000 1500 2000 3000
23.08.D	8	3%	6.000	0,03	500 1000 1500 2000 3000
23.10.D	10	3%	9.000	0,05	500 1000 1500 2000 3000
23.12.D	12	3%	13.000	0,07	500 1000 1500 2000
23.14.D	14	3%	18.000	0,08	500 1000 1500 2000
23.16.D	16	3%	23.000	0,12	500 1000 1500 2000
23.18.D	18	3%	29.000	0,17	500 800 1000
23.20.D	20	3%	36.500	0,20	500 800 1000

Dimensions and weights are without optional devices. All data may change without notice. Images and drawings are indicative only.

## C02...AC

Bright steel rope 216 wires + steel core. Construction 6 (14+7/7+7+1) WS+WR. Right and left crossed.  
UNI 7297-74. Resistance of wires: 180 kg/mm<sup>2</sup>.

OPTIONAL  
• Galvanization

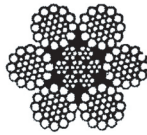

Nominal diameter	Wires diameter	Breaking load	Weight
mm	mm	kN	kg/m
6	0,38	27,2	0,15
8	0,50	47,3	0,28
10	0,62	75	0,43
11	0,68	89	0,52
12	0,75	108	0,62
14	0,77	131	0,82
16	0,88	168	1,07
18	0,99	220	1,35
20	1,10	270	1,68
22	1,22	320	2,03
24	1,33	380	2,40
26	1,44	450	2,83
28	1,55	504	3,30
30	1,66	600	3,80
32	1,77	670	4,33

## C02...LR

Bright steel rope 133 wires. Construction 19x7.  
Lang lay or regular lay. Resistance of wires 200 kg/mm<sup>2</sup>.

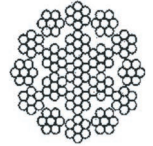

Rope diam.	Wires diam.	Sect.	Breaking load		Weight
mm	mm	mm <sup>2</sup>	kN	kN <sup>(1)</sup>	kg/m
<b>Lang lay</b>					
6	0,38	16,5	26	26	0,15
8	0,51	29,3	48,1	46,1	0,27
10	0,64	45,7	72,1	72,1	0,41
11	0,70	55,3	87,2	87,2	0,50
12	0,76	65,8	104	104	0,60
13	0,83	77,3	122	122	0,70
14	0,89	89,6	141	141	0,81
16	1,02	117	185	185	1,06
18	1,15	148	234	234	1,34
<b>Regular lay</b>					
20	1,27	183	288	281	1,66
22	1,40	221	349	340	2,01
24	1,53	263	415	405	2,39
26	1,65	309	487	475	2,81

(<sup>1</sup>) Galvanised type.

## C02...AR

Bright steel rope 216 wires "compacted strands", high resistance, with metal core.  
Resistance of wires: 220 kg/mm<sup>2</sup>

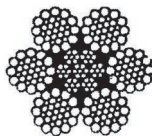

Nominal diameter	Wires diameter	Breaking load	Weight
mm	mm	kN	kg/m
10	0,59	90,2	0,45
11	0,66	111	0,55
12	0,72	132	0,67
13	0,78	153	0,78
14	0,84	176	0,90
16	0,96	240	1,18
18	1,08	294	1,48
20	1,20	367	1,85
22	1,32	443	2,25
24	1,41	525	2,50
26	1,53	613	3,04
28	1,64	704	3,64
30	1,76	809	4,20

## C02...AT

Bright steel rope. Construction 35x7. Resistance of wires 220 kg/mm<sup>2</sup>.



Nominal diameter	Wires diameter	Breaking load	Weight
mm	mm	kN	kg/m
8	0,40	49,2	0,26
10	0,50	77	0,42
12	0,60	110,8	0,60
14	0,70	150,9	0,82
16	0,80	197,1	1,07
18	0,90	249,4	1,36
20	1,00	308	1,68
22	1,10	372,6	2,03
24	1,20	443,5	2,42
26	1,30	520,5	2,84
28	1,40	603,6	3,29
30	1,40	693	3,78

Dimensions and weights are without optional devices. All data may change without notice. Images and drawings are indicative only.



# F162

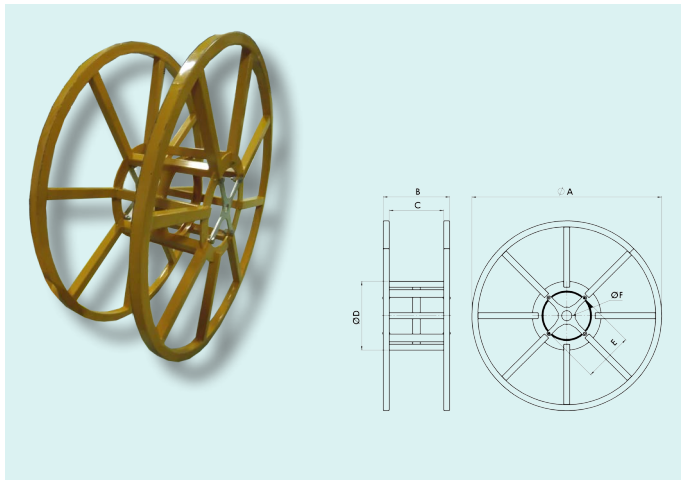

Welded and painted steel reel, complete with central dials and bolts.

### OPTIONAL DEVICES

- Total galvanization.
- Additional pair of standard dials.
- Pair of dials equipped with ball bearings.
- Reinforced reel, made of square tubular (30% heavier than the standard version).

	Dimensions mm						Weight (without rope)
	A	B	C	D	E	F	kg
F162.060	700	530	460	219		50	27
F162.110	1100	560	460	570	420	50	66
F162.140	1400	560	460	570	420	50	105
F162.160	1600	560	460	570	420	50	120
F162.190	1900	560	460	570	420	50	140
F162.220	2200	1560	1400	1010	420	100	950

# F164

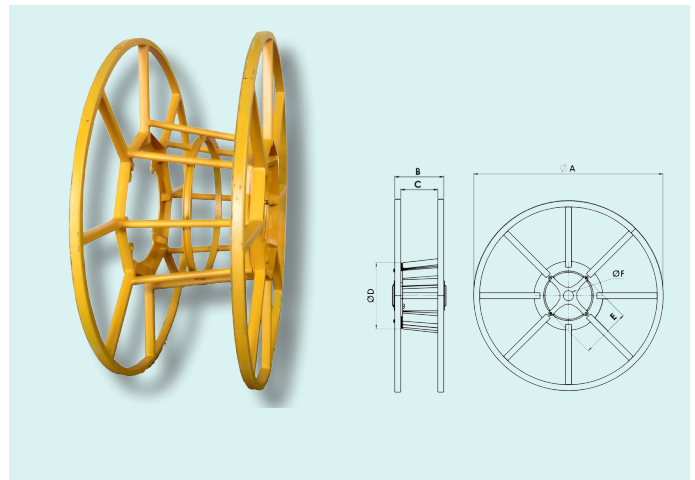

Welded and painted steel conical reel with openable side. Complete with central dials and bolts.

### OPTIONAL DEVICES

- Total galvanization.
- Additional pair of standard dials.
- Pair of dials equipped with ball bearings.
- Drum core covered with steel sheet.

	Dimensions mm						Weight (without rope)
	A	B	C	D	E	F	kg
F164.060	700	530	460	219		50	40
F164.110	1100	560	460	570	420	50	85
F164.140	1400	560	460	570	420	50	115
F164.160	1600	560	460	570	420	50	130
F164.190	1900	560	460	570	420	50	220
F164.205	2050	1310	1170	630	420	50	550
F164.220	2200	1310	1170	1010	420	100	1050

REEL CAPACITY (meters of rope)						
Rope diameter (mm)	F162.060	F162.110	F162.140	F162.160	F162.190	F162.220
	F164.060	F164.110	F164.140	F164.160	F164.190	F164.220
6	2000	6300	13000	17000	25000	-
7	1500	4500	9000	12000	18000	-
8	1200	3500	6000	5500	14000	-
9	900	2800	5400	7500	11000	-
10	800	2300	4400	6000	9000	33000
11	500	1900	3600	5000	7500	31000
12	450	1600	3000	4200	6000	22000
13	400	1400	2600	3600	5400	19000
14	300	1250	2200	3000	4600	16000
16	250	1000	1700	2400	3500	13000
18	-	800	1300	1900	2800	10000
20	-	650	1100	1600	2200	8000
22	-	500	900	1200	1900	6000
24	-	-	750	1000	1500	5000
26	-	-	650	900	1300	4500
28	-	-	560	800	1100	4000
30	-	-	490	700	1000	3500
32	-	-	430	600	850	3000

Dimensions and weights are without optional devices. All data may change without notice. Images and drawings are indicative only.



06  
**EQUIPMENT**



## GF..00

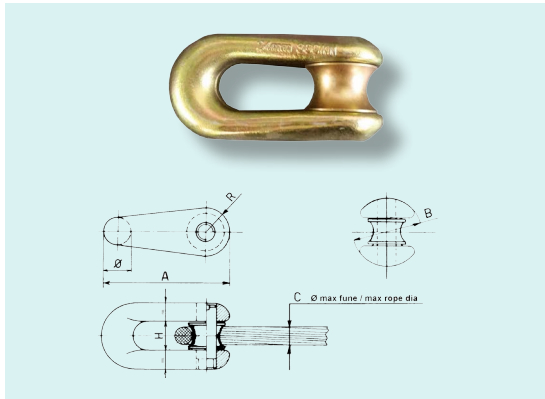

Joint made of high tensile galvanised steel, fit to connect pilot rope lengths and pulling rope. Designed to pass on the capstan grooves of pullers or puller/tensioners.

	Dimensions mm					for rope	W.L	Weight
	A	H	B	Ø	R	Ø mm	kN	kg
GF.10.00	68	14	36	17	13	10/12	23	0,20
GF.13.00	76	17	37	21	15	13/14	37	0,30
GF.16.00	96	19	50	22	20	16	53	0,60
GF.18.00	110	25	56	24	22	18/20	73	0,90
GF.24.00	125	26,5	60	28	24	22/24	120	1,30
GF.26.00	168	30	72	38	30	26/28	250	3,00
GF.32.00	178	35	80	44	34	28/32	280	3,50

## F250.R

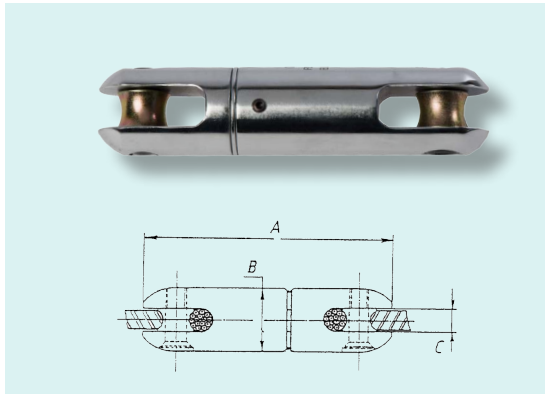

Swivel joint for ropes and conductors. Designed to release the torsion efforts during the pulling operations. Made of galvanised steel, complete with an axial bearing for an easy rotation.

	Dimensions mm			for rope	W.L	Weight
	A	B	C	Ø mm	kN	kg
F250.R.06.1	60	18	8,5	7	4	0,10
F250.R.08.1	96	24	12	9	8	0,22
F250.R.12.1	137	32	13	14	25	0,50
F250.R.13.1	152	39	17	16	40	1,00
F250.R.16.1	177	45	20	18	63	1,20
F250.R.18.1	182	52	22	22	80	2,60
F250.R.24.1	228	60	25	26	130	3,30
F250.R.28.1	310	80	36	32	260	7,00
F250.R.32.1	322	77	31	38	280	8,50

Dimensions and weights are without optional devices. All data may change without notice. Images and drawings are indicative only.

## C08

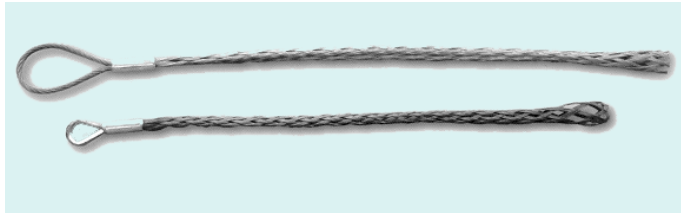

Dead end stocking for pulling underground cables.  
Long stocking type art. C08.L also available.

	Ø cable min - max	Length (¹)	Stocking length (²)	Breaking load
	mm	mm	kN	kg
C08.01	10-15	600	900	2000
C08.02	15-20	600	900	2000
C08.03	20-25	600	1000	2500
C08.04	25-30	600	1200	3000
C08.05	30-40	700	1500	4500
C08.06	25-45	700	1500	5000
C08.07	40-50	800	1500	5000
C08.08	45-60	800	1600	5000
C08.09	60-80	800	1800	8000
C08.10	80-100	1000	2000	10000
C08.11	100-140	1200	2000	10000
C08.12	140-170	1200	2000	10000
C08.13	170-200	1200	2000	10000

(¹) standard stocking (²) longer type stocking art. C08.L

## C09



Joining stocking for pulling underground cables.

	Ø cable min - max	Length	Breaking load
	mm	mm	kg
C09.01	10-15	1200	2000
C09.02	15-20	1200	2000
C09.03	20-25	1200	2500
C09.04	25-30	1200	3000
C09.05	30-40	1400	5000
C09.06	25-45	1400	5000
C09.07	40-50	1600	5000
C09.08	45-60	1600	5000
C09.09	60-80	1600	8000
C09.10	80-100	2000	10000
C09.11	100-140	2400	10000
C09.12	140-170	2400	10000
C09.13	170-200	2400	10000

## C10

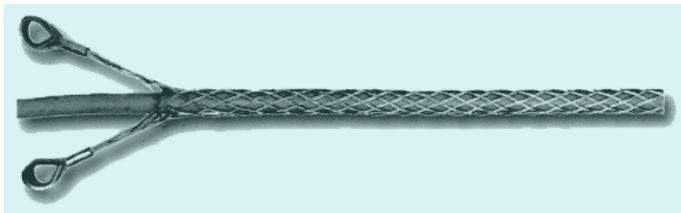

Double eye stocking for pulling underground cables.

	Ø cable min - max	Length	Breaking load
	mm	mm	kg
C10.01	10-15	800	2000
C10.02	15-20	800	2000
C10.03	20-25	800	2500
C10.04	25-30	800	3000
C10.05	30-40	1000	4500
C10.06	25-45	1000	5000
C10.07	40-50	1000	5000
C10.08	45-60	1000	5000
C10.09	60-80	1000	8000
C10.10	80-100	1200	10000
C10.11	100-140	1400	10000
C10.12	140-170	1400	10000
C10.13	170-200	1400	10000

## C11

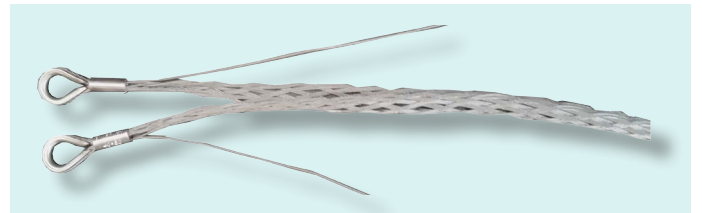

Double eye stocking with open sleeve for pulling underground cables.

	Ø cable min - max	Length	Breaking load
	mm	mm	kg
C11.01	10-15	800	2000
C11.02	15-20	800	2000
C11.03	20-25	800	2500
C11.04	25-30	800	3000
C11.05	30-40	1000	4500
C11.06	25-45	1000	5000
C11.07	40-50	1000	5000
C11.08	45-60	1000	5000
C11.09	60-80	1000	8000
C11.10	80-100	1200	10000
C11.11	100-140	1400	10000
C11.12	140-170	1400	10000
C11.13	170-200	1400	10000

Dimensions and weights are without optional devices. All data may change without notice. Images and drawings are indicative only.

## C108.A



Galvanised steel cable roller.

**FEATURES**

Max load	180 kg
Max cable	Ø 120 mm
Roller	Ø 70/110 x 185 mm
Dimensions	300 x 240 x 250 mm
Weight	4,1 kg

## C108.A1



Heavy version with shielded bearings.

**FEATURES**

Max load	400 kg
Max cable	Ø 200 mm
Roller	Ø 80/130 x 280 mm
Dimensions	300 x 300 x 260 mm
Weight	7,1 kg

## C108.B



Aluminium cable roller with galvanised steel base.

**FEATURES**

Max load	200 kg
Max cable	Ø 120 mm
Roller	Ø 75/115 x 175 mm
Dimensions	300 x 240 x 250 mm
Weight	4,5 kg

## C108.C



Straight cable roller with 3 aluminium rollers.

**FEATURES**

Max load	200 kg
Max cable	Ø 150 mm
Roller	Ø 50/60 x 100 mm
Dimensions	250 x 250 x 250 mm
Weight	4,9 kg

## C108.E

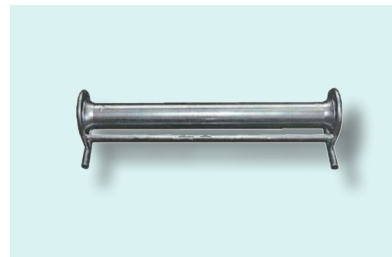

Galvanised horizontal cable roller.

**FEATURES**

Max load	400 kg
Max cable	Ø 120 mm
Roller	Ø 75/110 x 800 mm
Dimensions	850 x 250 x 250 mm
Weight	13 kg

## C108.E1

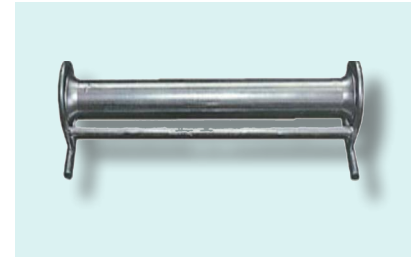

Heavy version shielded bearings.

**FEATURES**

Max load	1000 kg
Roller	Ø 80 x 950 mm
Dimensions	1000 x 250 x 250 mm
Weight	22 kg

## C108.F



Galvanised cable guiding run-off frame.

**FEATURES**

Max load	300 kg
Roller	Ø 35 x 620 mm
Dimensions	1050 x 470 x 520 mm
Weight	14 kg

## C108.F1

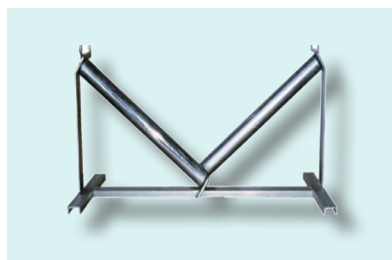

Heavy version with shielded bearings.

**FEATURES**

Max load	1000 kg
Roller	Ø 80 x 700 mm
Dimensions	1200 x 600 x 450 mm
Weight	28 kg

Dimensions and weights are without optional devices. All data may change without notice. Images and drawings are indicative only.

## C109.A



**C109.A** Galvanised steel cable roller.

**C109.A1** Heavy version with shielded bearings.

	max load	max cable	rollers	dimensions	weight
	kg	mm	mm	mm	kg
C109.A	300	Ø 120	Ø 83x200	370x330x420	17
C109.A1	1000	Ø 200	Ø 90x250	400x360x420	27

## C109.B

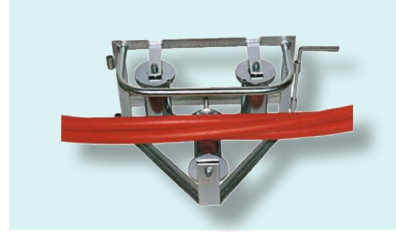

**C109.B** Galvanised steel corner roller.

**C109.B1** Version with aluminium rollers.

**C109.B2** Heavy version with shielded bearings.

	max load	max cable	rollers	dimensions	weight
	kg	mm	mm	mm	kg
C109.B	300	Ø 120	Ø 75/110x185	550x340x370	14
C109.B1	350	Ø 120	Ø 70/130x170	550x340x370	17
C109.B2	1000	Ø 200	Ø 80/130x280	600x400x420	31

## C109.C

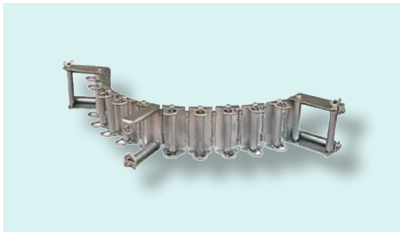

Chain of rollers for bends made of 12 horizontal rollers and 6 vertical rollers. Made of galvanised steel.

	max load	rollers	dimensions	weight
	kg	mm	mm	kg
C109.C	200	Ø 32x180	230x1300	28

## C109.D

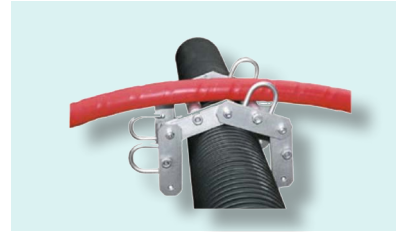

Galvanised chain rollers.

	max load	rollers	rollers	dimensions	weight
	kg	mm	n°	mm	kg
C109.D.3	100	Ø 32x185	3	420x230x120	4
C109.D.4	100	Ø 32x185	4	540x230x120	4,5
C109.D.5	100	Ø 32x185	5	670x230x120	5
C109.D.6	100	Ø 32x185	6	820x230x120	6

## C109.E



**C109.E** Galvanised roller guide with swivel angled base.

**C109.E1** Heavy version in painted steel.

	max load	rollers	dimensions	weight
	kg	mm	mm	kg
C109.E	120	Ø 75/110x130	350x250x210	5,8
C109.E1	200	Ø 135/205x80	315x250x230	18,2

Dimensions and weights are without optional devices. All data may change without notice. Images and drawings are indicative only.



## C109.G

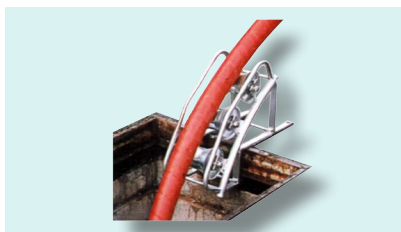

**C109.G** Galvanised triple guide roller for manholes.  
**C109.G1** Version with aluminium rollers.

	rollers	dimensions	weight
	mm	mm	kg
C109.G	Ø75/110x180	500x220x400	13
C109.G1	Ø70/130x170	500x220x400	17

## C109.I



Adjustable boom with aluminium cable roller.

	rollers	boom length	weight
	mm	mm	kg
C109.I.1	Ø110/210x110	300-500	12
C109.I.2	Ø110/210x110	500-800	15
C109.I.3	Ø110/210x110	600-1000	19
C109.I.4	Ø110/210x110	1000-1500	24
C109.I.5	Ø110/210x110	1500-1800	27
C109.I.6	Ø110/210x110	1800-2400	30

## C109.M

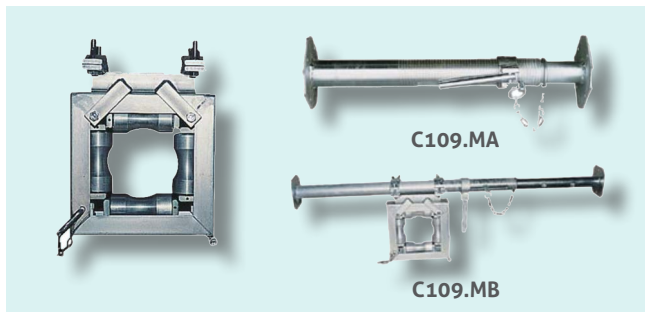

**C109.M** Cable guiding device with 4 protection rollers.  
**C109.MA** Adjustable boom for cable guiding device C109.M.  
**C109.MB** Cable guiding device with 4 protection rollers Ø60mm (C109.M), complete with adjustable boom (C109.MA).

## C109.H



Adjustable boom with aluminium cable roller.

	rollers	boom length	weight
	mm	mm	kg
C109.H.1	Ø110/210x110	300-500	9,5
C109.H.2	Ø110/210x110	500-800	10
C109.H.3	Ø110/210x110	600-1000	13
C109.H.4	Ø110/210x110	1000-1500	16
C109.H.5	Ø110/210x110	1500-1800	18
C109.H.6	Ø110/210x110	1800-2400	23

## C109.L

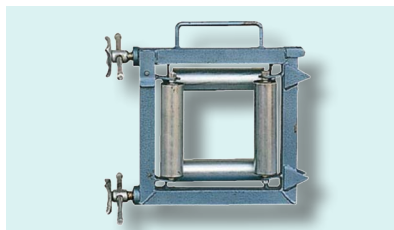

Cable guiding device with 4 protection rollers.

	passage between rollers	rollers	dimensions	weight
	mm	mm	mm	kg
C109.L	250	Ø 60	550x130x500	15

	passage between rollers	rollers	dimensions	weight
	mm	mm	mm	kg
C109.M	250	Ø 60	550x130x500	15

	boom length	weight	boom length	weight	
	mm	kg	mm	kg	
C109.MA.1	500-800	7	C109.MB.1	500-800	10
C109.MA.2	600-1000	10	C109.MB.2	600-1000	13
C109.MA.3	1000-1700	12	C109.MB.3	1000-1700	15
C109.MA.4	1400-2400	14	C109.MB.4	1400-2400	17

Dimensions and weights are without optional devices. All data may change without notice. Images and drawings are indicative only.

## C110.A

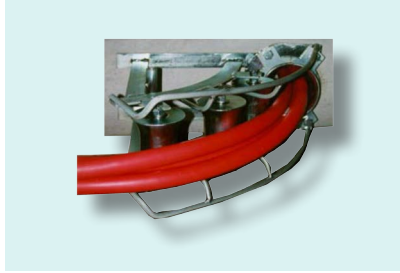

Galvanised steel cable and rope entrance device.

	bending radius	Ø socket	weight
	mm	mm	kg
C110.A.07	420	75	16,5
C110.A.09	420	90	17,0
C110.A.10	420	101	17,5
C110.A.12	420	114	18,0
C110.A.15	420	152	18,5
C110.A.17	420	168	19,0

## C110.B



Galvanised steel cable and rope entrance device.

	bending radius	Ø socket	weight
	mm	mm	kg
C110.B.07	1000	75	22,0
C110.B.09	1000	90	22,5
C110.B.10	1000	101	23,0
C110.B.12	1000	114	23,7
C110.B.15	1000	152	24,5
C110.B.17	1000	168	25,0

## C110.C



Galvanised spare socket for rope entrance devices C110.A and C110.B.

	Ø external	weight		Ø external	weight
	mm	kg		mm	kg
C110.C.07	75	1,0	C110.C.12	114	1,9
C110.C.09	90	1,5	C110.C.15	152	2,0
C110.C.10	101	1,7	C110.C.17	168	2,1

## C110.M

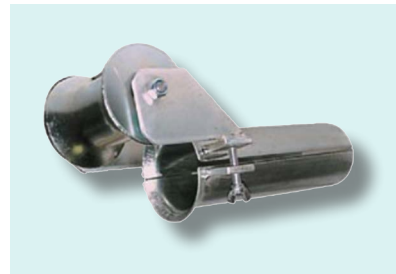

Galvanised cable protector with roller.

	Ø external	weight		Ø external	weight
	mm	kg		mm	kg
C110.M.05	51	4,0	C110.M.10	114	6,0
C110.M.06	61	4,2	C110.M.12	133	7,0
C110.M.07	75	4,5	C110.M.13	140	7,3
C110.M.09	89	5,0	C110.M.15	152	7,5

## C110.P

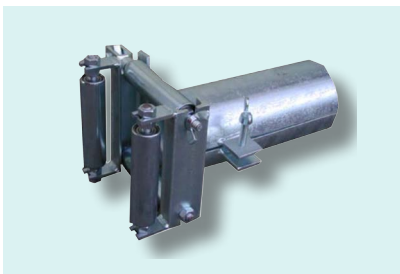

Galvanised cable entrance device with adjustable double protection.

	Ø external	weight		Ø external	weight
	mm	kg		mm	kg
C110.P.05	51	2,5	C110.P.13	140	6,4
C110.P.07	75	3,5	C110.P.15	152	6,6
C110.P.09	89	4,2	C110.P.17	169	7,4
C110.P.10	114	5,0	C110.P.20	196	8,3
C110.P.12	133	6,2			

Dimensions and weights are without optional devices. All data may change without notice. Images and drawings are indicative only.





**OMAC**  
via Pizzo Camino, 13  
24060 Chiuduno (BG) - Italy  
T +39 035 838092 - F +39 035 839323  
omac@omac-italy.it



watch the video