

TALON P-1C PROFILE SHARPENER

MULTI AXIS OPERATING SYSTEM UPGRADE!

TALON
3 YEAR
or up to 3 million
tips unconditional
parts warranty



The Talon P-1C is designed to profile grind circular saws with a state-of-the-art computer control system to accurately profile grind, maintain wheel shape, diameter, and wheel R.P.M. With unmatched performance you will be able to achieve superior saw quality allowing higher cutting performance. The computerized controller can store many tooth profiles with the ability to set automatic wheel shaping and adjusting. The PP65 Power Panel with 30 function keys and Color TFT display with QVGA resolution simplifies operation and makes programming by the end user a viable option. The Talon can also be linked to the internet for program downloading of the tooth profiles.

SAW SHARPENING SYSTEMS

See us on the Internet at ...
WWW.WRIGHTTOOLS.COM

TALON P-1C PROFILE SHARPENER

FEATURED IMPROVMENTS!

- Ethernet 10/100 And 2 USB Ports For Online Communication And Upgrades.
- Synchronous Servo Motors & Motor Drives = More Torque In A Smaller Package With Smoother Motion.
- I/O: Input And Output Connections Are All Funneled To One Location With Individual Lights Indicating Status.
- On Screen Diagnostics.
- Program Tooth shapes from CAD Drawing.
- Precision Ball Screws.
- Precision Linear Motion Slides.
- 2 H.P. Spindle Motor.
- Quick Change Clamp Jaws.
- Automatic Wheel Shaping.
- Filtered Full Flood Coolant.
- Arc Index To Match Saw Diameter.
- High Output Air Operated Coolant Pump.

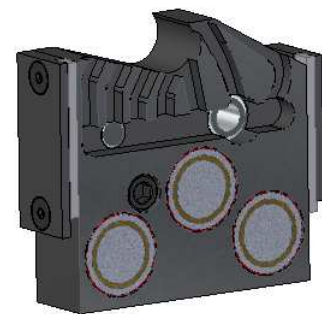

SPECIFICATIONS

Circle saw diameter	8"-28"
Power Consumption	1.5 kw
voltage standard	230V 3PH 50/60
Air	2 C.F.M @ 80 P.S.I.
Ship Weight	2,100 LBS.
Crate Size	73" X 49" X 81"

WRIGHT MACHINE TOOL
 365 PALMER AVE.
 COTTAGE GROVE, OREGON
 97424
 PH. 541-942-3712

Specifications and availability subject to change without notice.



See us on the Internet at ...
WWW.WRIGHTTOOLS.COM