



# Operating Instructions and Service Manual

## T-2 Model Cooling Towers

MEMBER



196 Lower Cherry Street  
Macon, GA 31201  
800-752-1905  
478-755-1905  
800-203-4925 FAX  
478-755-8304 FAX

[www.coolingtowersystems.com](http://www.coolingtowersystems.com)  
[info@coolingtowersystems.com](mailto:info@coolingtowersystems.com)



# Preface

Adequate knowledge of cooling tower maintenance and control is necessary for optimum, safe performance over time. In this manual, equipment construction, function, operation and checking procedures will be described as follows:

## (1) TOWER CONSTRUCTION

### 1.1 Type

CTS incorporates an induced-draft counter-flow design with an axial flow fan mounted on top of the tower to draft air out. The low internal pressure loss and circular-shaped design ensure optimum efficiency and space economy.

### 1.2 Casing

The F.R.P. (fiberglass reinforced polyester) is composed of fiberglass mat laminated from unsaturated polyester resin. The high structural strength of the material protects the unit against impact and cracking. Gel coat is then applied to form a smooth surface.

### 1.3 Water Basin

Also made of F.R.P. material. The circular-shaped basin with a cylindrical suction sump (ST200-1000) keeps cavitation of the pump to a minimum. A drain connection is provided for removal of accumulated dirt from the basin.

### 1.4 Tower Support Framework

(a) T-25 – T-2175: The F.R.P. base legs are incorporated with the water basin in a single unit to withstand wind pressure and vibration.

(b) T-2200 – T-3000: Provided with hot-dip galvanized steel to resist corrosion and rust.

### 1.5 Motor Support Framework

Made of hot-dip galvanized steel to resist corrosion and rust.

### 1.6 Air Inlet Louver

The P.V.C. plastic mesh is fitted on the air inlet to prevent foreign material from falling into the basin of water splashing out of the basin.

### 1.7 Filling

Made of rigid polyvinyl chloride sheet which is embossed and corrugated in a honeycomb configuration. It provides maximum air-to-water contact for highest thermal efficiency.

### 1.8 Sprinkler Device

Consists of a set of sprinkler pipes and one sprinkler head that is mounted on top of the stand pipe on the cooling tower. The sprinkler is rotated by the pressure of circulating water. There are numerous holes in the sprinkler pipe to allow the water to jet out as the pump impacts rotation.

The speed can be controlled by adjusting the sprinkling angle in accordance with the water flow rate. There are two types of sprinkler heads.

- (a) T-25 – T-260 (refer to figure 1): The outer casing is made of nylon material; the sliding part is lubricated by the water.

- (b) T-270 – T-3000 (refer to figure 2): The whole body is made of aluminum alloy and is fitted with sealed type bearings to take thrust and radial loads and to ensure that the sprinkler head revolves smoothly.

## 1.9 Fan Blade

The cooling tower blades move large volumes of air quietly and efficiently.

- (a) T-25 – T-230: Made of reinforced plastic material, the blades are coupled to the fan hub by bolts and paste.
- (b) T-240: Made of aluminum alloy, the blades are freely adjustable by the pitch angle scale of the fan hub.

## (2) PREPARATIONS FOR STARTING

### 2.1

Open the drain at the bottom of the water basin and wash dust and dirt away while scrubbing the water basin with a brush.

### 2.2 Trial Circulation Wafer

Fill water in the water basin to the level where the discharge from the ball tap stops. Slowly rotate the sprinkler by hand to check whether it is free. Start the circulating pump, and after washing the interior of the tower and the water pipes thoroughly, refill the circulating water.

### 2.3 Checking

After the circulation test, check if there is any dirt or foreign matter sticking to the interior of the tower or the outlets of the sprinkling pipes. Check to see if the speed reducer belt has been adjusted correctly.

After confirming that the fan revolves smoothly by turning it by hand, check the state of the gap between the tip of the blades and the tower casing. Measure the supplied voltage and make sure that the power supply is in the regulated type. Revolve the fan for a short time and make sure that air is blown upward. Revolve the fan two or three hours to see if any vibrations or abnormal sounds are generated.

Slowly move the float of the ball tap up and down and make sure the discharge and control system of water is accurate.

In case the tower has been left idle for a long time, check the following points and make sure that nothing is wrong.

Confirm the insulation of the motor with a megger (see that it is 1M $\Omega$  or above using a 500V megger).

See that no loose nuts are found at various important junctions such as the tightened places of fan driving motor and the junctions between the supporting base and the tower casing. Turn the sprinkler with hand and see if it operates smoothly.

**(3) STARTING**

**3.1 Pump Driving**

In order to make the circulating water fill every part of the circulation system, revolve the circulation pump for a short while, to drain the air out of the piping of the circulating water.

Before entering steady operation, confirm again that the water basin is filled to the specified level, and then start the pump.

Gradually open the adjusting valve and adjust it so that the water will reach the volume specified on the name plate of the cooling tower. When circulation of water becomes steady, check to see if the sprinkler is revolving smoothly and properly.

**3.2 Fan Driving**

Clean up the surroundings of the tower and make sure that no foreign matter is near the air inlet and outlet.

When the equipment goes into steady operation, measure phase voltages and phase currents to see if the motor is operating at the rated current range indicated on the name plate.

**(4) CAUTIONS DURING OPERATION**

**4.1 Performance**

Since the cooling performance will be affected by the volume of the circulating water, be sure to maintain the regulation water flow at all times.

Keep the interior of the tower always clean and take care that no scale or moss grows.

**4.2 Water Level**

When the level of the water in the water basin drops, air is sucked in and "cavitation" may develop; therefore, it is necessary to keep the water at the proper level at all times.

**4.3 Functioning**

Pay close attention to the vibration, noise, temperature of the cooling water and electric current during operation and make sure that nothing goes wrong. Vibrations or noises come mainly from the moving parts in the speed reducer and the fan, be careful not to overlook even a slight defect.

Revolution of the Sprinkler							
T-2	3	5-30	40-60	80-250	300-350	400-700	800-3000
RPM	12-17	7-10	5-8	5-7	3.5-5	2.5-4	2-3

Sprinkler Head										
T-2 Model No:	3-10	15-20	25-40	50-60	70-100	125-175	200-250	300-400	500-700	800-1000
LSU Model No:	-040-	-050-	-065-	-080-	-100-	-125-	-150-	-200-	-250-	-300-

Item No:	Specifications						
	Description	LSH-100	LSH-125	LSH-150	LSH-200	LSH-250	LSH-300
1	Cap						
2	Circlip						
3	Bearing	6301Z	6302Z	6302Z	6303Z	6304Z	6405
4	Bearing Housing						
5	Center Pole						
6	Bearing	6002Z	6003Z	6003Z	6004Z	6005Z	6006Z
7	Oil Seal						
8	Spring Washer						
9	Nut						
10	Head						
11	Body						

(D) V-Belts

Maintain belt adjustment as described above. This drive uses high quality special V-belts. The V-belts are designed to operate 5,000 to 10,000 hours. If slipping or belt abrasion becomes evident after operating over 5,000 hours then replace the belt sets. If after 5,000 hours, excessive adjustments of belt tension are required due to belt stretch, the belts have reached

the end of their life and should be replaced with belts as recommended in the V-belt table. Since V-belts are not widely available, please contact our nearest distributor for replacement. **Belts must always be replaced in matched sets: i.e., both upper and lower sets must be replaced simultaneously.** Hence, one faulty belt requires the replacement of up to 10 belts.

V-Belt Table (I)						
V-Belt Speed Reducer Model No.	T-2 Model	Fan Speed R.P.M.	Belts No. V-Belt Model No.	Belts No. of Upper Pulley	Belts No. of Lower Pulley	Belts No. Total
LBM-055C	225 & 250	398	2-11MS-800	1	-	1
			3-11MS-800	-	1	1
LBM-075	300 & 350	398	2-11MS-800	-	2	2
			3-11MS-800	1	-	1
LBM-110	400 & 500	342	2-11MS-1400	1	-	1
			3-11MS-1400	-	1	1
LBM-150	600 & 700	282	2-11MS-1400	1	1	2
			3-11MS-1400	-	1	1
LBM-220	800 & 1000	265	2-11MS-1550	-	2	2
			3-11MS-1550	1	1	2

V-Belt Table (II)						
V-Belt Speed Reducer Model No.	T-2 Model	Fan Speed R.P.M.	Belts No. V-Belt Model No.	Belts No. of Upper Pulley	Belts No. of Lower Pulley	Belts No. Total
LBM-055C	225 & 250	398	11M-800	2	3	5
LBM-075	300 & 350	398	11M-800	3	4	7
LBM-110	400 & 500	342	11M-1400	2	3	5
LBM-150	600 & 700	282	11M-1400	2	5	7
LBM-220	800 & 1000	265	11M-1550	3	7	10

**MOTOR AND V-BELT SPEED REDUCER**

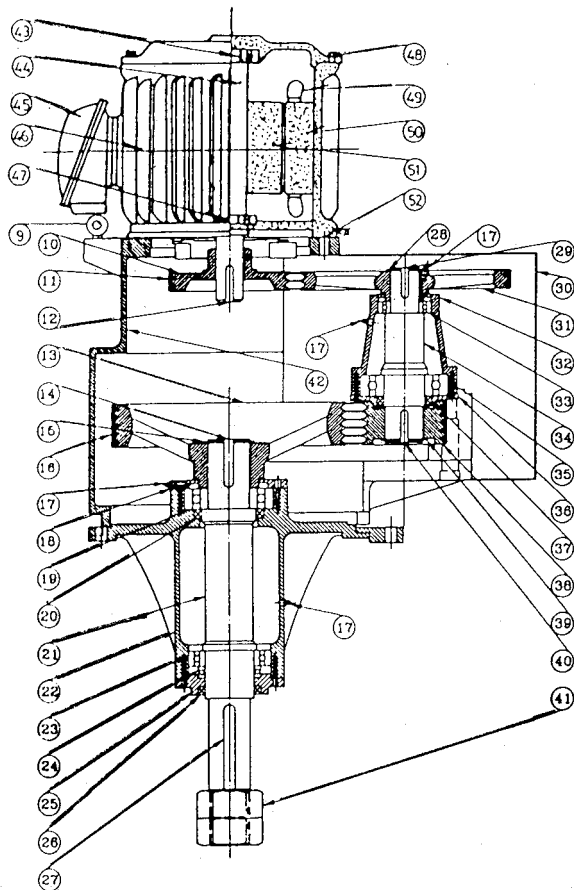

**V-BELT SPEED REDUCER SECTION**

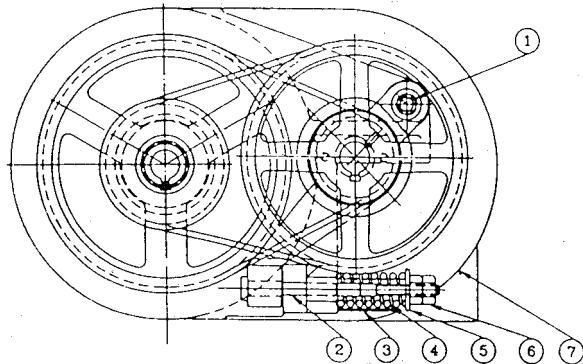

Item No.	Description
1	Support Pin
2	Adjusting Lever
3	Adjusting Gauge
4	Adjusting Spring
5	Washer
6	Adjusting Bolt
7	Sight Glass
8	Cooling Fan
9	Lifting Ring
10	Pulley No. 1
11	V-Belts (Upper)
12	Key A
13	Pulley No. 4
14	Key D
15	Circlip D
16	V-Belts (Lower)
17	Grease Nipple
18	Housing Cover No. 1
19	Bearing D
20	Oil Seal D
21	Fan Shaft
22	Housing (Fan Shaft)
23	Bearing E
24	Bearing G
25	Housing Cover No. 2
26	Oil Seal E
27	Key E
28	Circlip B
29	Key B
30	Belt Cover
31	Pulley No. 2
32	Interm. Shaft Housing
33	Bearing B
34	Intermediate Shaft
35	Bearing C
36	(Interm. S.) Housing Cover
37	Oil Seal C
38	Pulley No. 3
39	Circlip C
40	Key C
41	Fan Shaft Nut
42	Belt Case
43	Bearing F
44	Motor Shaft
45	Terminal Box
46	Stator Frame
47	Bearing A
48	Set Screw 1
49	Stator Coil
50	Stator Core
51	Rotor Core
52	Set Screw 2

**V-BELT SPEED REDUCER BEARING TABLE**

V-Belt Speed Reducer Model No.	LBC Model	Bearing						
		F	A	B	C	D	E	G
LBM-055C	225 & 250	6306zz	6308zz	6207z	6309z	6211z	6012z	51112
LBM-075	300 & 350	6306zz	6308zz	6208z	6310z	6211z	6012z	51112
LBM-110	400 & 500	6308zz	6309zz	6208z	6310z	6213z	6213z	51113
LBM-150	600 & 700	6308zz	6309zz	6209z	6313z	NJ313	NJ215	51115
LBM-220	800 & 1000	6309zz	6311zz	6213z	6317z	NJ317	NJ217	51117
LBM-300	1250 & 1500	6312zz	6312zz	6213z	6317z	NJ317	NJ217	51117

**(5) MAINTENANCE AND CONTROL**

**5.1 Sprinkler Pipe**

The sprinkler pipe must be clean without blockage. If there is some foreign material retarded in the pipe, take the following steps:

- (A) Loosen the set screw or lock nut on sprinkler device, then remove sprinkler pipe and clean.
- (B) Align the dot mark on sprinkler head and reinstall.

For T-25 – T-215 models, they are fitted with type A and B pipe (the hole pitch is different to assure even water distribution).

**5.2 Sprinkler Head**

The sprinkler head rotation will slow or even stop if scale is stuck to it. In this case, check it as follows:

- (A) T-25 – T-260 (refer to Fig. 1)
  - a. remove set screw cap on top of sprinkler head.
  - b. loosen nut and washer, then take head off.
  - c. clean it with fresh water and check if any component is worn out.
- (B) T-270 – T-3000 (refer to Fig. 2)
  - a. remove the cap and take circlip off.
  - b. pull the rotary part off the fixing part and check: replace if necessary.

**5.3 Tower Casing**

No coating is needed for the tower casing as it is made of F.R.P. If it becomes soiled, wipe it with soap or a water-soaked piece of cloth and then wash it thoroughly with water.

**5.4 Water Basin**

As dust and dirt are liable to get into the water basin, open the drain at the bottom of the drop-in tank from time to time and wash it clean. This applies also to the water basin in particular, as sediments are liable to accumulate near the outlet, so keep the tank clean so that the strainer mesh will not be clogged.

**5.5 Filling**

No special care is needed if the control of the quality of water is adequate during operation.

**5.6 Fan**

Watch the surface of the blades carefully to see that no damage develops and make sure that proper space is maintained between the internal wall of tower casing and the tip of blades.

**5.7 Coating**

It is desirable to periodically recoat the metal parts as they are subject to rusting.

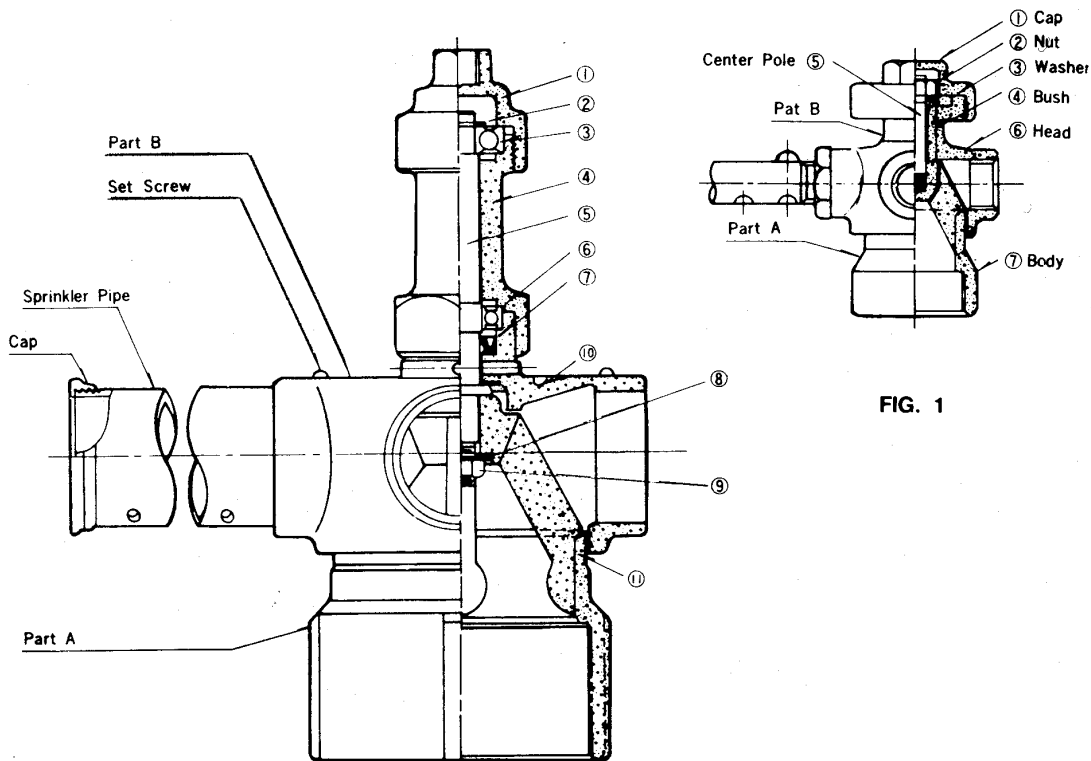

**FIG. 2**

**FIG. 1**



**(6) V-BELT SPEED REDUCER**

With increasing public awareness of noise, our engineers have developed a V-belt drive to reduce operating noise levels.

This new drive produces much lower noise levels than those obtained from conventional gear drives of the equivalent size. The V-belt is a wide angle (60°C) and is made of a special polyurethane compound with polyester tension cords (tensile member). Very compact V-belt drives are possible with this belt.

The life of the belts depends on the maintenance of proper tension. The adjusting gauge is factory set and should not be altered.

**6.2 Testing of Drive Operation**

After checking the belt adjustment, spin the fan by hand to see whether it is free. If it spins freely and smoothly, start the fan motor. After 2 to 4 hours operation, check amperage and voltage and compare the readings with motor nameplate data. Check the motor temperature and check noise and vibration.

T-2 Model No.	5-8	10-15	20-30	40-50	60-80	100-125	150-200	225-350	400-500	600-700	800-1000
LSF Model No.	-050-	-070-	-080-	-100-	-120-	-150-	-180-	-240-	-300-	-340-	-360-

With proper maintenance, the V-belt drive will operate reliably; however, proper maintenance is essential and the following instructions are very important.

**6.1 Belt Adjustment**

Before operation, open the adjustment access cover and check whether the washer on the adjusting bolt is aligned with the adjusting gauge. (Ref. Fig. A) Tighten the adjusting nut if necessary.

During operation, the belt may stretch, allowing belt slip and abrasion. Hence, the belt tension should be checked according to the following:

- (A) 50 hours after commissioning.
- (B) Thereafter, carry out 3 checks, each at 100 hour intervals.
- (C) After the 4<sup>th</sup> check, at 350 hours, then check each month.

Off-Season Shut Down – For a long-time shut down, slacken the adjusting nut 4-5mm to prevent bolt stretch. Re-adjust belts prior to putting the cooling tower back into service.

Adjustment Precaution – If a gap exists between the adjusting gauge and the washer, the belts are too slack. If the washer and the adjusting nut overlap the adjusting gauge, the belts are too tight.

**6.3 Maintenance**

The following work should be performed.

**(A) Drive Section**

Clean out the inside of the driving section annually.

**(B) Motor Insulation**

Before putting the tower into service in each cooling season, check the motor insulation with a 500 Volt Megger. A resistance greater than 1MΩ is acceptable.

**(C) Bearings**

Although it is unnecessary to lubricate the sealed bearings, an annual change of grease will extend their life. To repack the bearings, remove the seal plates with a sharp tool inserted as indicated by the arrow in Fig. B. Replace the seal plates after replacing the bearings.

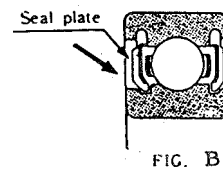
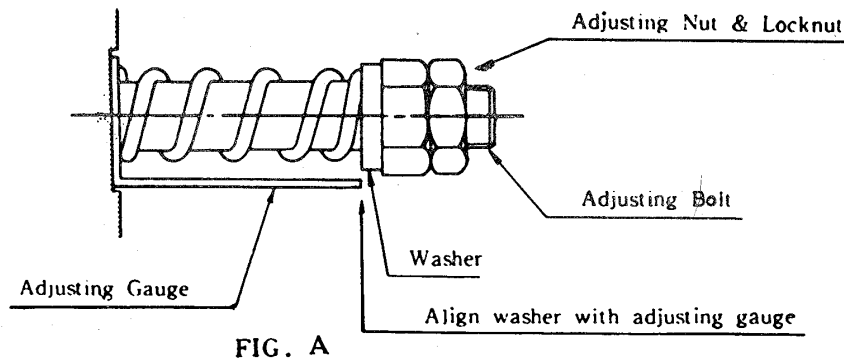

To replace belts, remove the belt cover from the belt case, slacken the adjusting nut and push the intermediate pulley assembly toward the motor (refer Fig. C). Remove old belts and replace with new sets.

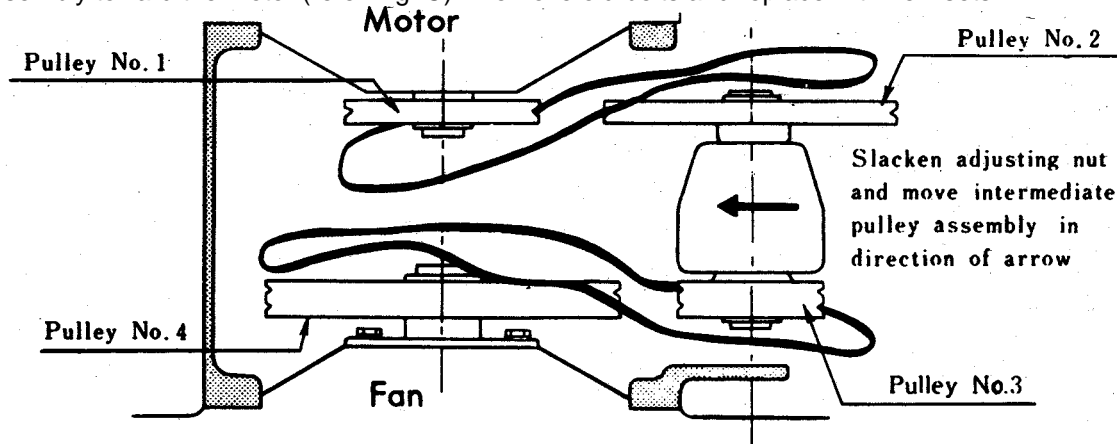

**FIG. C**

**(7) PRECAUTIONS IN PROLONGED IDLENESS**

Unless the circulation water is drained, it may freeze in winter and cause the pipes to crack. If the drain of the drop-in tank is kept open, rain-water and snow water will not accumulate in it. Make sure that tightening bolts on the various parts of the tower, especially on the moving parts are tight. As the cooling tower is installed on top of the roof, it is desirable to cover up the tower casing and the air exhaust outlet.

**(8) WATER TREATMENT**

**A. Bacterial Contamination**

Bacterial contamination of recirculated water in the cooling tower is possible.

It is therefore recommended that, after the cooling

tower is commissioned, a regular maintenance program be investigated. This should include treatment of the recirculated water.

As we are not experts in this field, we strongly recommend that a reputable water treatment company be consulted for the treatment of the system's recirculated water.

**B. Water Quality Control**

Poor quality of recirculated water due to air pollution, corrosion, scale and algae growth will impede the performance of water cooling equipment. We recommend a periodic water analysis and that blow-down be initiated to maintain the water quality within the water cooling system to the following criteria:

Permissible Value of Water Analysis (JCI Code)		
PARAMETER	Make-up water	Circulating water
PH (25° C)	6-8	6-8
Electric conductivity (µv/cm)	200 below	500 below
Total hardness (CaCO <sub>3</sub> ) ppm	50 below	200 below
M alkalinity (CaCO <sub>3</sub> ) ppm	50 below	100 below
Chlorine ion (Cl) ppm	50 below	200 below
Sulphuric acid ion (SO <sub>4</sub> ) ppm	50 below	200 below
Silicic acid (SiO <sub>2</sub> ) ppm	30 below	50 below
Ferric (Fe) ppm	0.3 below	1.0 below



<b>Trouble Analysis Table</b>		
<b>Trouble</b>	<b>Causes</b>	<b>Counter-Measures</b>
Rise in cooling water temperature	<ol style="list-style-type: none"> <li>1. Excess or inadequate cooling water flow.</li> <li>2. Irregular flow of air.</li> <li>3. Recirculation of air exhausted from tower.</li> <li>4. Irregular operation of sprinkler pipes.</li> <li>5. Improper flow of air.</li> <li>6. Blocking of the filling.</li> </ol>	<ol style="list-style-type: none"> <li>1. Adjust to the specified flow.</li> <li>2. Improve ventilation.</li> <li>3. Same as above or install baffles.</li> <li>4. Remove dust and scale.</li> <li>5. Adjust the angle of fan blades.</li> <li>6. Clean the blocked areas.</li> </ol>
Drop in the volume of cooling water	<ol style="list-style-type: none"> <li>1. Blocking of the sprinkler pipe holes.</li> <li>2. Blocking of strainer mesh.</li> <li>3. Drop in the water level of water basin.</li> <li>4. Improper selection of water circulating pump.</li> </ol>	<ol style="list-style-type: none"> <li>1. See section for maintenance and adjustment.</li> <li>2. Remove strainer and clean.</li> <li>3. Adjust float valve.</li> <li>4. Replace the pump with one matching planned volume of water.</li> </ol>
Noise and vibration	<ol style="list-style-type: none"> <li>1. Fan blade tips touching fan stack.</li> <li>2. Improper mounting of fan blades.</li> <li>3. Loose belts.</li> <li>4. Shortage of speed reducer oil.</li> </ol>	<ol style="list-style-type: none"> <li>1. Adjust the fan mounting.</li> <li>2. Correct the blade angle settings.</li> <li>3. Tighten loose bolts.</li> <li>4. Supply oil up to the level specified.</li> </ol>
Excessive current draw	<ol style="list-style-type: none"> <li>1. Drop in voltage.</li> <li>2. Irregularities in the angles of the fan blades.</li> <li>3. Overload through excess airflow.</li> </ol>	<ol style="list-style-type: none"> <li>1. Check supply voltage. Notify power company if necessary.</li> <li>2. Adjust fan blade angles.</li> <li>3. Adjust fan blade angles.</li> </ol>
Water carry over	<ol style="list-style-type: none"> <li>1. Irregular operation of sprinkler pipes.</li> <li>2. Blocking of the filling.</li> <li>3. Defective eliminator.</li> <li>4. Too much circulating water.</li> </ol>	<ol style="list-style-type: none"> <li>1. Adjust the angle of the sprinkler pipes in the sprinkler head.</li> <li>2. Eliminate blockage at the upper edge of the filling.</li> <li>3. Renew the eliminator.</li> <li>4. Adjust the water flow by means of the valve.</li> </ol>

Construction & Installation Data

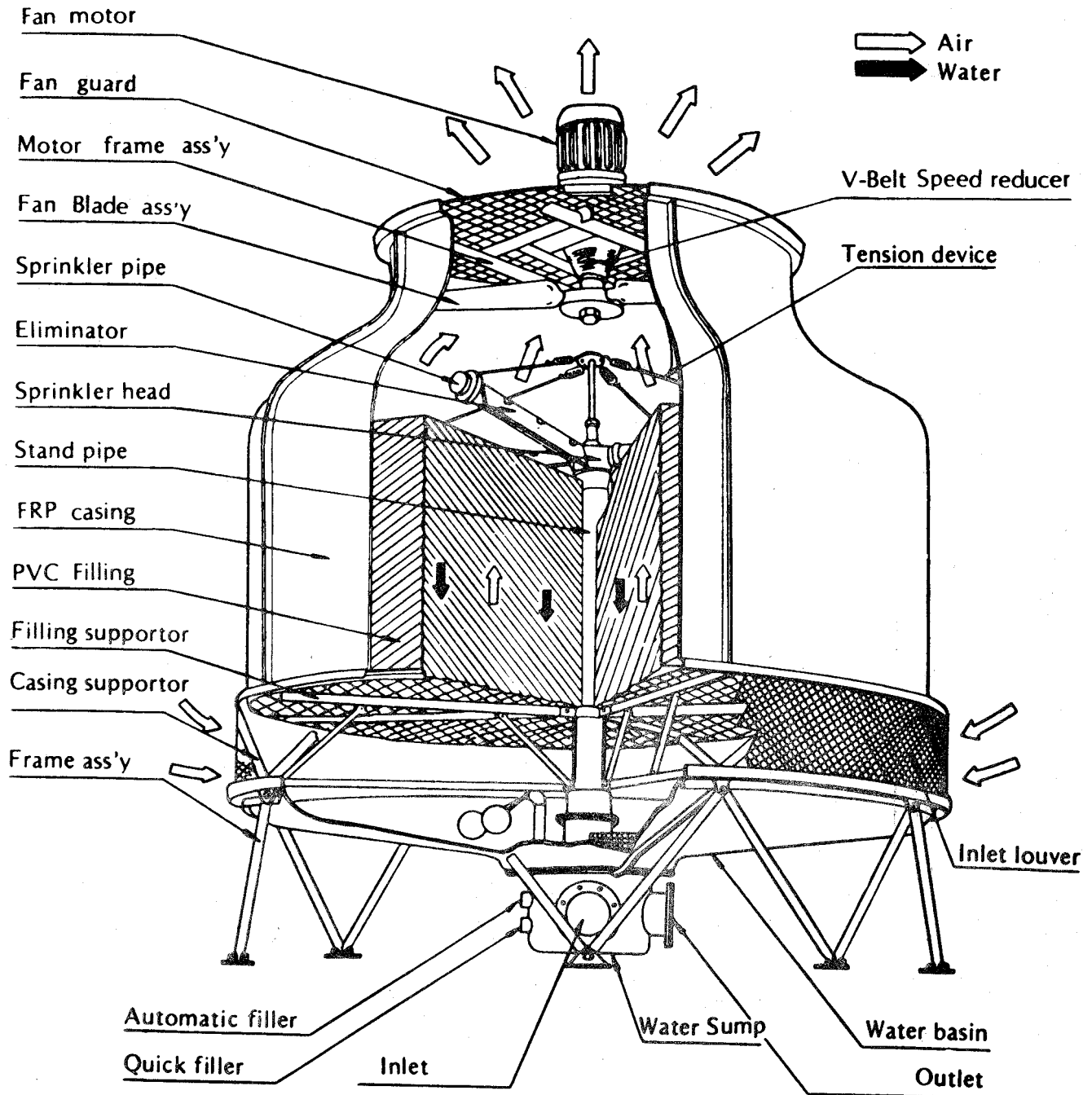

## Guarantee

**COOLING TOWER SYSTEMS, INC. GUARANTEE IS AS FOLLOWS:**

**DOMESTIC – WITHIN THE CONTINENTAL UNITED STATES:**

- A. Ten Years on FRP, (fiberglass) casing, and cold water basins.
- B. Two (2) years on all PVD fillings.
- C. One (1) year on all fan motors, major drive components, and all internal moving parts.

NOTE: An Extended Manufacturer's Warranty is available, for an additional nominal fee, and is set into place as part of the original purchase.

**INTERNATIONAL ORDERS/WARRANTY:**

- A. **Eighteen (18) months, after shipping date.**
- B. One (1) year, after initial start-up of Cooling Tower.
- C. \*Note – only "A" or "B" is applicable, which ever comes first.

Cooling Tower Systems, Inc. wishes to *Thank You* for your patronage and we look forward to adding you as a satisfied customer!