



*The Best Just Got Better*

---

# MODEL T-2700

# TOWER SPECIFICATIONS



---

Cooling Tower Systems, Inc.

196 Lower Cherry Street Macon, GA 31201

TF: 800.752.1905

F: 478.755.8304

[www.coolingtowersystems.com](http://www.coolingtowersystems.com)

[info@coolingtowersystems.com](mailto:info@coolingtowersystems.com)



# TOWER SPECIFICATIONS: MODEL T-2700 Cooling Tower Systems, Inc.

Design and Operating Conditions		Water Distribution System Construction Materials	
Tower Type:	Counter Flow Induced Draft	Stand Pipe:	PVC
Water Flow Rate (GPM):	2,101 GPM	Sprinkler Head:	AC
Entering Water Temperature	95°F	Sprinkler Pipes:	PVC
Leaving Water Temperature	85°F	<b>Mechanical Equipment</b>	
Wet Bulb Temperature:	75°F	Fan Unit:	One Unit per Tower
Total Fan BHP:	20 HP	Type:	Axial Flow
Total Pump Head:	18.2'	Manufacturer:	CTS
Drift Loss of Water Flow:	0.1%	Diameter:	133 1/8"
Evaporation Loss of Water Flow:	0.93%	Blade Material:	AC
Design Wind Load:	41 lbs/sq. ft.	Hub Material:	AC
<b>Structural Details</b>		Nominal Air Volume:	125,000 CFM
Overall Diameter:	259 7/8"	<b>Fan Motor</b>	
Overall Height:	181 5/16"	Number of motors:	One Unit per Tower
Dry Weight:	7,863 lbs.	Type:	Induction
Operating Weight:	27,896 lbs.	Manufacturer:	CTS
<b>Basic Tower Construction Materials</b>		Insulation:	F Class
Tower Support Frame Assembly	HDGS	Rated HP:	20 HP
Casing:	FRP	Voltage and phase:	220/440V/3
Casing Supporters	HDGS	<b>Piping Connections</b>	
Cold Water Basin	FRP	Primary Water Inlet Diameter	10"
Filling:	PVC	Primary Water Outlet Diameter:	10"
Filling Supports:	HDGS	Auto fill inlet diameter:	2"
Fan Guard	HDGS	Quick fill inlet diameter:	2"
Mechanical Equipment Supports:	HDGS	Overflow outlet diameter:	4"
Inlet Louvers:	PVC	Drain diameter:	2"
Bolts, Nuts & Washers:	STS	Water Flow (GPM):	2,101 GPM
<b>Materials Key</b>			
FRP	Fiberglass Reinforced Polyester	STS	Stainless Steel
HDGS	Hot Dipped Galvanized Steel	AC	Aluminum Alloy Cast

**Cooling Tower Systems, Inc.**

196 Lower Cherry Street Macon, GA 31201

TF: 800.752.1905

F: 478.755.8304

www.coolingtowersystems.com

info@coolingtowersystems.com

# PARTS LIST: MODEL T-2700

FOR ASSEMBLY DIAGRAM		
Ref. No.	Description	QTY
01-01	Base Plate - A	8
01-02	Ring Frame	8
01-03	Truss Pipe - A1	8
01-04	Truss Pipe - A2	8
01-06	Tie Rod	8
02-01	Water Sump	1
02-02	Outlet Nozzle	1
02-03	Inlet Nozzle	1
02-04	Over Flow Nozzle	1
02-05	Drain Nozzle	1
02-06	Automatic Filler Nozzle	1
02-08	Float Valve Assembly	2
02-09-01	Over Flow	1
02-09-02	Overflow Connector Pipe	1
02-10	Suction Strainer	1
02-12A	Connector	1
03-01	Water Basin	16
04-01	Base Plate - B	8
04-02	Stiffener Ring - 1	8
04-03	Truss Pipe - B1	8
04-04	Truss Pipe - A1	8
05-01	Casing (Diffuser)	16
05-02	Casing (Cylinder)	16
05-06	Hand Hole Cover	1
06-01	Stand Pipe	1
06-02	Stand Pipe Base	1
06-03	Packing	1
07-02	Column	1
08-01	Filling Supporter - A	8
08-02	Filling Supporter - B	8
08-03	Filling Supporter - C	24
08-04	Fill Supt. Clamping Band	16
08-06	Filling Supporter - E	16
10-01-1	Ladder (A Section - 1)	1
10-01-2	Ladder (A Section - 2)	1
10-02	Ladder (B Section)	1
10-03	Ladder Bracket - A	2
10-04	Ladder Bracket - B	2
11-01	Filling (Inner Section)	-
11-03	Filling (1/3 Section)	6
11-06	Filling (1/6 Section)	-
11-08	Filling (1/8 Section)	16
11-09	Filling (1/10 Section)	-
12-01	Sprinkler Head	1
12-02	Center Post	1
12-03	Turnbuckle	8
12-04	Tension Wire	8
13-01	Sprinkler Pipe	8
13-02	End Cap	8
13-03	Eliminator	8
14-01	Frame Ass'y Main Pipe	2
14-02	Frame Ass'y Stay Pipe	2
15-01	Motor Base	1
15-02	U-Bolt	4
15-03	U-Bolt	4
16-01	Motor	1
16-02	Speed Reducer	1

16-03	Fan Key	1
16-04	Fasten Nut	1
16-05	Lock Nut	1
17-01	Fan Hub	1
17-02	Fan Blade	4
17-04	U-Bolt	8
18-01	Fan Guard	8
19-00	Basin Supporter Ass'y	16
20-01	Louver Supporter	48
20-01B	Louver Supporter - B	48
20-02	Inlet Louver	16
20-08	Wing Bolt	144
20-09	Plastic Washer	144
OTHERS	Bolts & Nuts	1 SET

FOR TECHNICAL DIAGRAMS			
Item	Description	Material	QTY
1	Fan Motor	-	1 pcs
2	V-Belt Reducer	-	1 set
3	Motor Frame Assembly	HDGS	1 set
4	Fan	AC	1 set
5	Fan Guard	HDGS	1 set
6	Casing	FRP	16 pcs
7	Hand Hole	EVA	1 pcs
8	Sprinkler Head	AC	1 set
9	Sprinkler Pipe	PVC	8 pcs
10	Eliminator	FRP	8 pcs
11	Tension Device	HDGS	1 set
12	Stand Pipe	PVC	1 set
13	Filling	PVC	1 set
14	Stopper or Column	HDGS	1 set
15	Filling Supporter	HDGS	1 set
16	Casing Supporter	HDGS	6 pcs
17	Inlet Louver	PVC	1 set
18	Frame Assembly	HDGS	1 set
19	Water Basin	FRP	12 pcs
20	Water Sump	FRP	1 pcs
21	Ladder	HDGS	1 set
22	Strainer	HDGS	1 pcs
23	Flange	HDGS	2 pcs
24	Basin Supporter	HDGS	16 pcs

Materials Key	
FRP	Fiberglass Reinforced Polyester
HDGS	Hot Dipped Galvanized Steel
STS	Stainless Steel
AC	Aluminum Alloy Cast
Water Basin Sealing Material	
Fiberglass	1 Set—A
Polyester	1 Keg—B
Catalyst	1 Bottle—C

Cooling Tower Systems, Inc.

196 Lower Cherry Street Macon, GA 31201

TF: 800.752.1905

F: 478.755.8304

www.coolingtowersystems.com

info@coolingtowersystems.com



# ASSEMBLY DIAGRAM: MODEL T-2700

Cooling Tower Systems, Inc.

Pictured below is LBM Vbelt speed reducer hook up

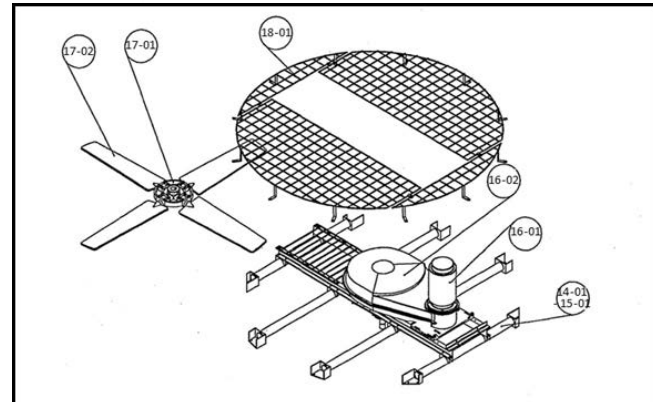
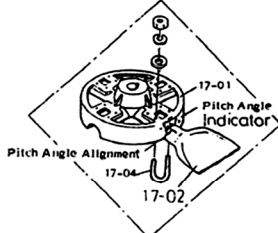
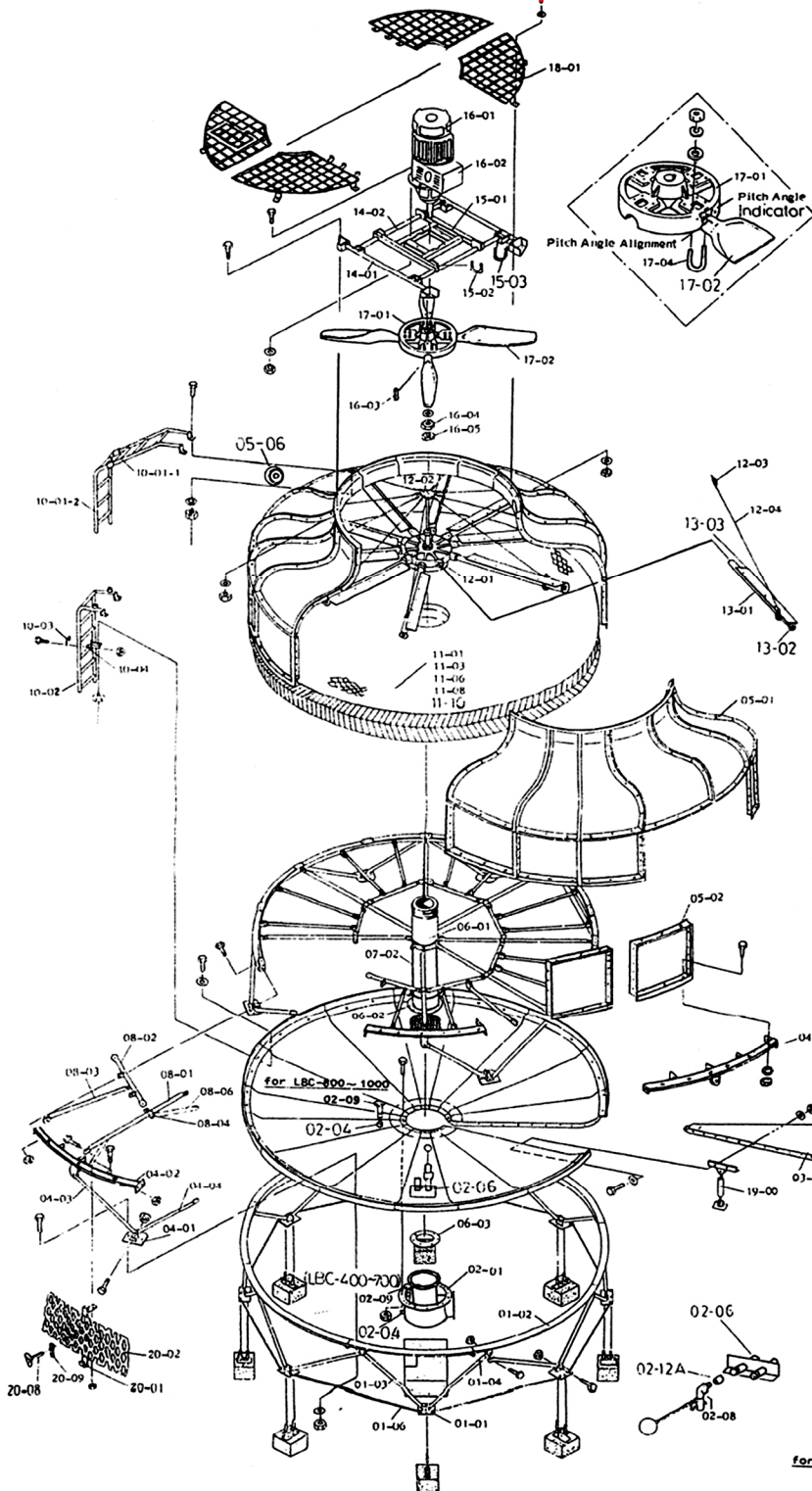

\*Pictured above is VBA style right angle drive vbelt speed reducer hook up. All parts are the same but mounting is as shown above.

Cooling Tower Systems, Inc.

196 Lower Cherry Street Macon, GA 31201

TF: 800.752.1905

F: 478.755.8304

www.coolingtowersystems.com

info@coolingtowersystems.com



Cooling Tower Systems, Inc.

# TECHNICAL IMAGE A: MODEL T-2700

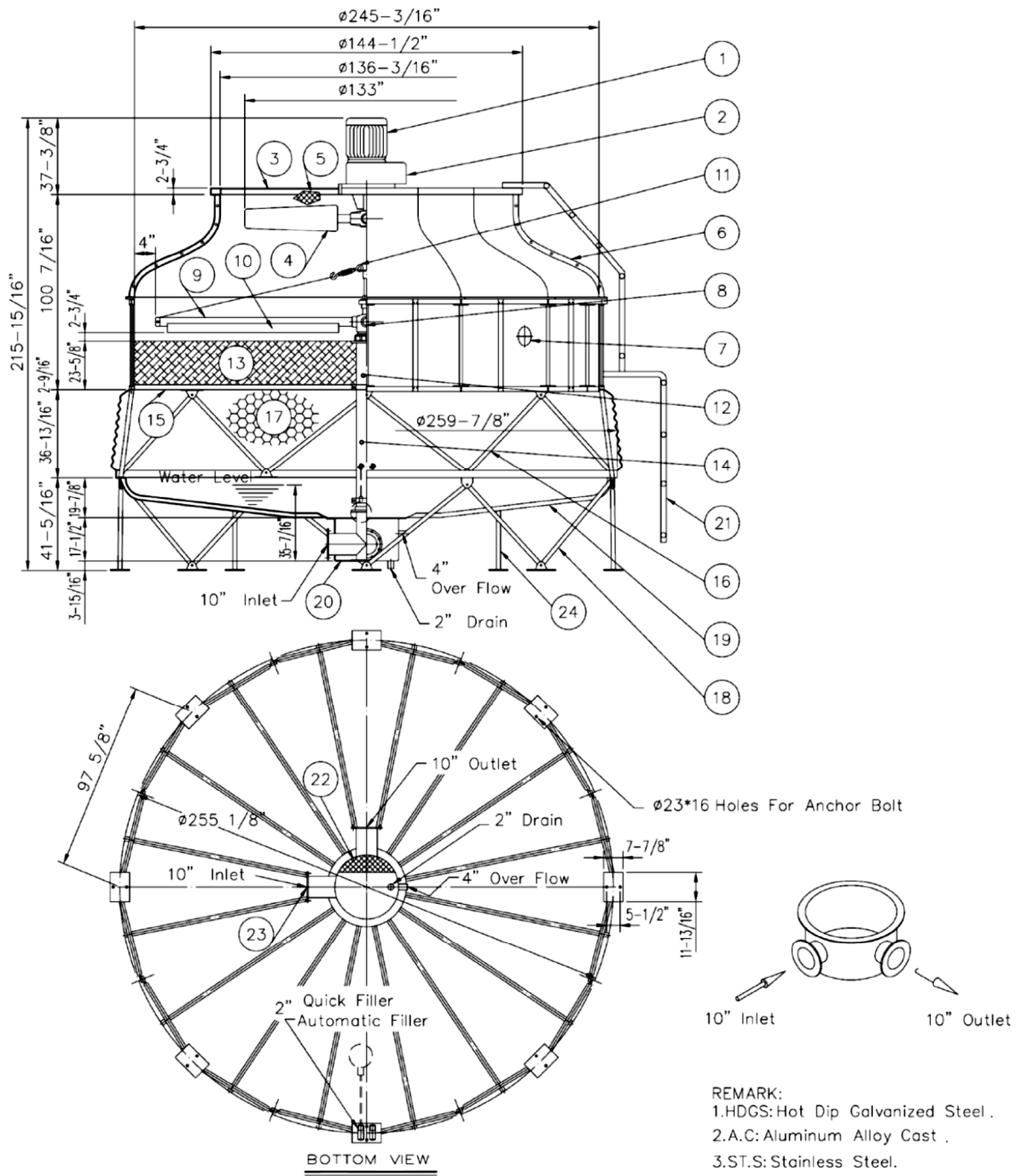

Cooling Tower Systems, Inc.

196 Lower Cherry Street Macon, GA 31201

TF: 800.752.1905

F: 478.755.8304

www.coolingtowersystems.com

info@coolingtowersystems.com



# FOUNDATION DRAWING: MODEL T-2700 Cooling Tower Systems, Inc.

T-	øD	W	øD1	L TYPE ANCHOR BOLT		
				SIZE	L	PCS
2600	141 3/4	97 5/8	255 1/8	W3/4	8	16
2700	141 3/4	97 5/8	255 1/8	W3/4	8	16
2800	163 1/2	113	295 1/4	W3/4	8	16
3000	163 1/2	113	295 1/4	W3/4	8	16

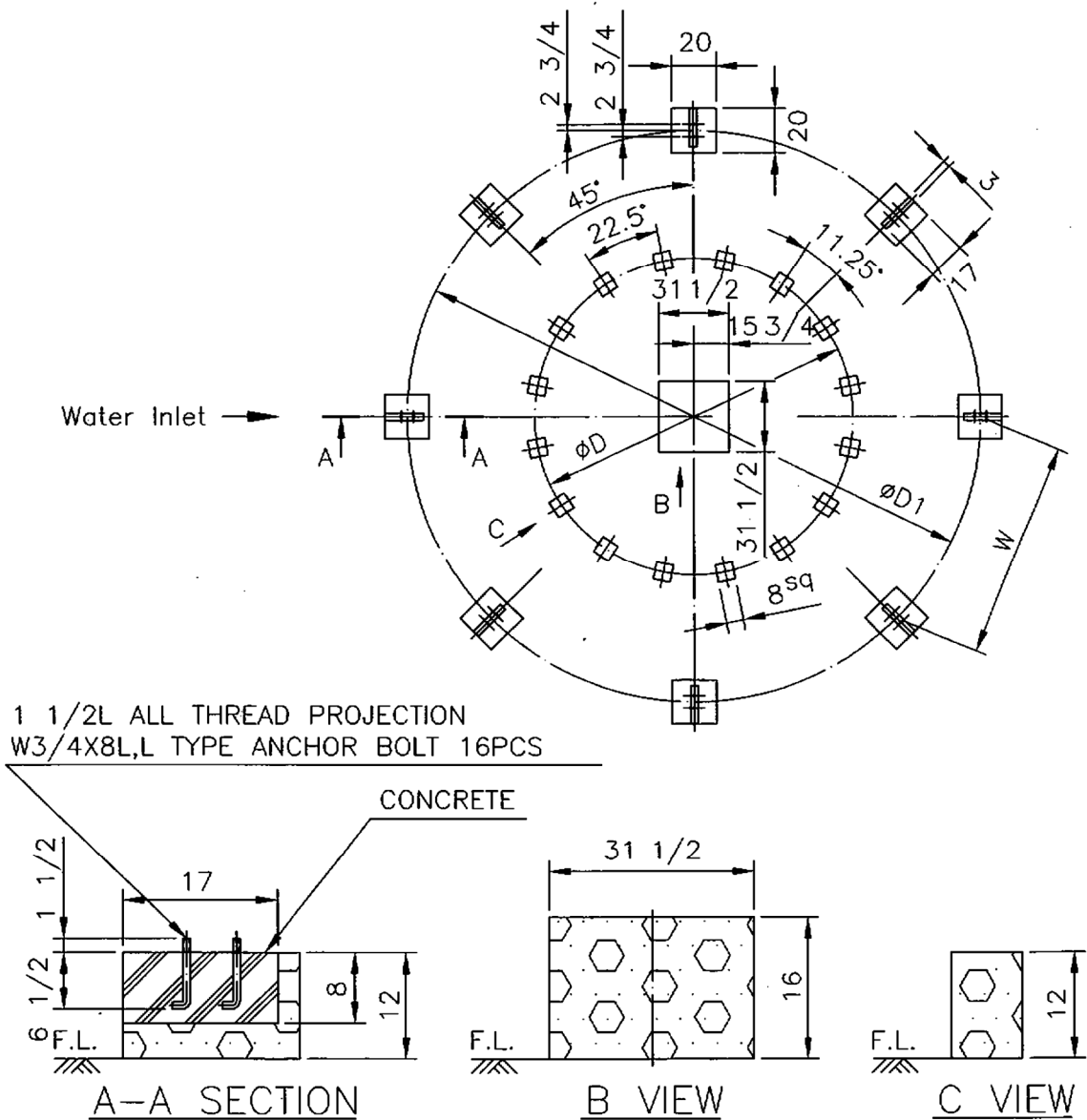

Cooling Tower Systems, Inc.

196 Lower Cherry Street Macon, GA 31201

TF: 800.752.1905

F: 478.755.8304

www.coolingtowersystems.com

info@coolingtowersystems.com



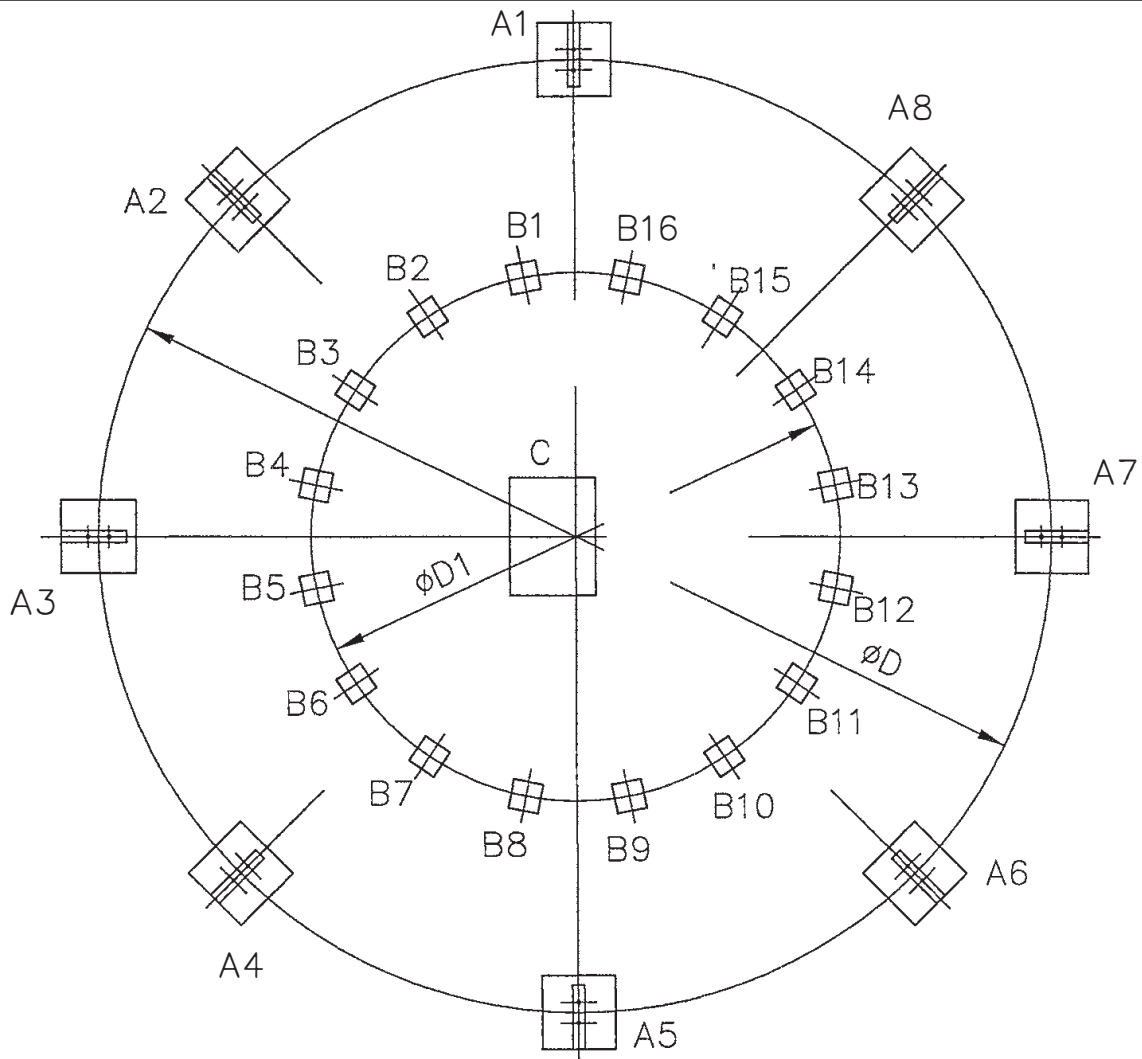

TOWER MODEL T-2	$\phi D$	$\phi D1$	DEAD LOAD		
			A1=...=A8	B1=...=B16	C
600	255 1/8"	141 3/4"	1602lb	250lb	10627lb
700	255 1/8"	141 3/4"	1635lb	244lb	10904lb
800	295 1/4"	163 1/2"	2461lb	345lb	16140lb
1000	295 1/4"	163 1/2"	2524lb	327lb	16502lb

TOWER MODEL T-2/3	LIVE LOAD		
	A1=...=A8	B1=...=B16	C
600	433lb	68lb	2870lb
700	459lb	72lb	3044lb
800	563lb	88lb	3737lb
1000	596lb	94lb	3956lb