



Series e-1531 Pumps

THE INDUSTRY STANDARD IN END SUCTION PUMP DESIGN

TECHNICAL BROCHURE

Series e-1531 Close-Coupled Pumps

Standard Design Features

- 1. Internally Flushed Mechanical Seals** ensure maximum seal face lubrication, heat dissipation and debris removal without vulnerable, external flush tubing. As much as 25 percent of the total pump flow continuously flushes the seal faces.
- 2. Back Pull-out** design allows one service tech ease of maintenance.
- 3. Stainless Steel Shaft Sleeve** construction is standard. Special sealing between the sleeve and shaft prevents corrosion of the shaft by the pumped fluid.
- 4. ISO G6.3 Balanced Impeller** for quiet, vibration-free performance. Impellers are precision fitted to the shaft and positively locked with a shaft key.
- 5. Heavy Duty Cast Iron Volute** construction for 175 PSI working pressure.
- 6. Jacking bolts** provide ease of volute disassembly.
- 7. Gauge tappings** on the suction and discharge flanges along with volute vent and drain tappings are standard.
- 8. Hydrostatic testing** of each pump is standard.

Pump Options

- Stainless Steel Volute Wear Ring
- External Flush Line
- Stuffing Box Configuration
- Epoxy Coated Internal Cast Iron Components
- Special Impeller Balancing (ISO 1940 G2.5 or G1.0)
- Certified Performance Tests (Per HI Standard 14.6)

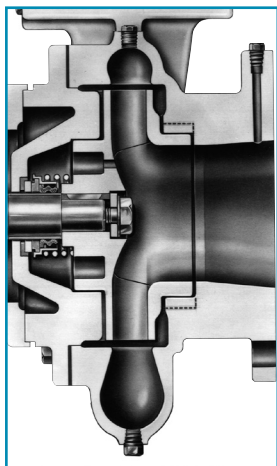
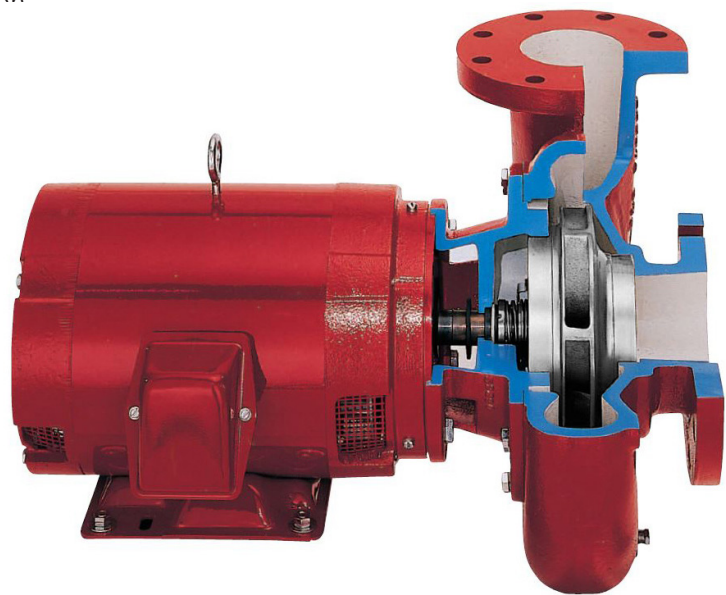

Standard Configuration

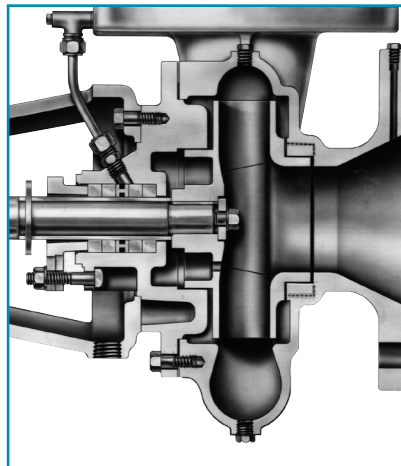

Stuffing Box Configuration

Series e-1531 Materials of Construction

Description	Stainless Steel Fitted
1 Shaft	Carbon Steel Grade per Motor Manufacturer
2 Volute	Cast Iron ASTM A48 Class 30B
3 Impeller	ASTM A743 Grade CF8 - 304 Stainless Steel
4 Shaft Sleeve	ASTM A312 Grade TP304 - 304 Stainless Steel
5 Impeller Key	#304 Stainless Steel
6 Impeller Washer	Steel
7 Impeller Lock Washer	#304 Stainless Steel
8 Impeller Cap Screw	#304 Stainless Steel
9 Volute Gasket	Cellulose Fiber
10 Seal Assembly	Reference Tables Below

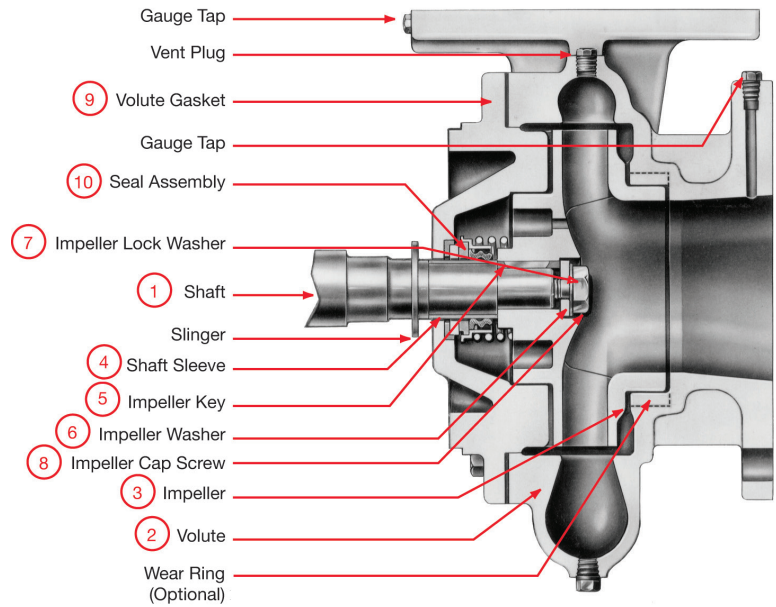

Standard Mechanical Configuration

Standard Mechanical Seal	
Temperature Range	-20 to 225°F
Maximum Pressure	175 PSI
pH Limitations	7.0 - 9.0
Elastomer	Buna
Rotating Face	Carbon
Stationary Face	Ceramic
Hardware	Stainless Steel / Brass

Mechanical Seal Options			
Temperature Range	-20 to 250°F	-10 to 225°F	-20 to 250°F
Maximum Pressure	175 PSI	175 PSI	175 PSI
pH Limitations	7.0 - 11.0	7.0 - 9.0	7.0 - 12.5
Elastomer	EPR (Ethylene Propylene Rubber)	FKM (Viton™ or Fluoroelastomer)	EPR (Ethylene Propylene Rubber)
Rotating Face	Carbon	Carbon	Silicon Carbide
Stationary Face	Tungsten Carbide	Ceramic	Silicon Carbide
Hardware	Stainless Steel / Brass	Stainless Steel	Stainless Steel

Stuffing Box Configuration

Mechanical Seal	
Temperature Range	-20 to 300°F*
Maximum Pressure	175 PSI
pH Limitations	7.0 - 11.0
Elastomer	EPR (Ethylene Propylene Rubber)
Rotating Face	Tungsten Carbide
Stationary Face	Carbon
Hardware	Stainless Steel

Packing Option	
Temperature Range	0 to 250°F
Maximum Pressure	175 PSI
pH Limitations	7.0 - 9.0
Material	Braided Graphite Impregnated PTFE

recommended for temperatures above 225°F for optimum seal life. On closed systems cooling is accomplished by inserting a small heat exchanger in the flush line to cool the seal flushing fluid. Flush-line Filters and Sediment Separators are available on special request.

* For operating temperatures above 250°F a cooled flush is required and is

Job/Project:	Representative:	
ESP-Systemwize: WIZE-6A20CE	Created On: 09/15/2020	Phone:
Location/Tag:	Email:	
Engineer:	Submitted By:	Date:
Contractor:	Approved By:	Date:

Close Coupled End Suction Pump

Series: e-1531

Model: 1.5BC



Features & Design

- "Best in Class" hydraulic performance
- Best choice for lowest life cycle cost
- Internally self-flushing mechanical seals
- Hydrostatic testing of each pump standard

*The Bell & Gossett Series e-1531 is available in 18 sizes and a variety of configuration options that enable customization and flexibility to fit a broad range of operating conditions.

<http://bellgossett.com/pumps-circulators/end-suction-pumps/e-1531/>

Pump Selection Summary

Duty Point Flow	125 US gpm
Duty Point Head	240 ft
Control Head	0 ft
Duty Point Pump Efficiency	57.8 %
Part Load Efficiency Value (PLEV)	0.0 %
Impeller Diameter	7.5 in
Motor Power	15 hp
Duty Point Power	13.3 bhp
Motor Speed	3600 rpm
RPM @ Duty Point	3525 rpm
NPSHr	23 ft
Minimum Shutoff Head	253 ft
Minimum Flow at RPM	33.9 US gpm
Flow @ BEP	170 US gpm
Fluid Temperature	68 °F
Fluid Type	Water
Weight (approx. - consult rep for exact)	260 lbs
Pump Floor Space Calculation	2.88 ft ²

Performance Curve

Energy Efficiency Ratings:

Pump & Motor PEIc: 0.83 ERcI: 17
Pump, Motor & Drive: PEIv: 0.42 ERvI: 58



e-1531
1.5BC
3525 RPM

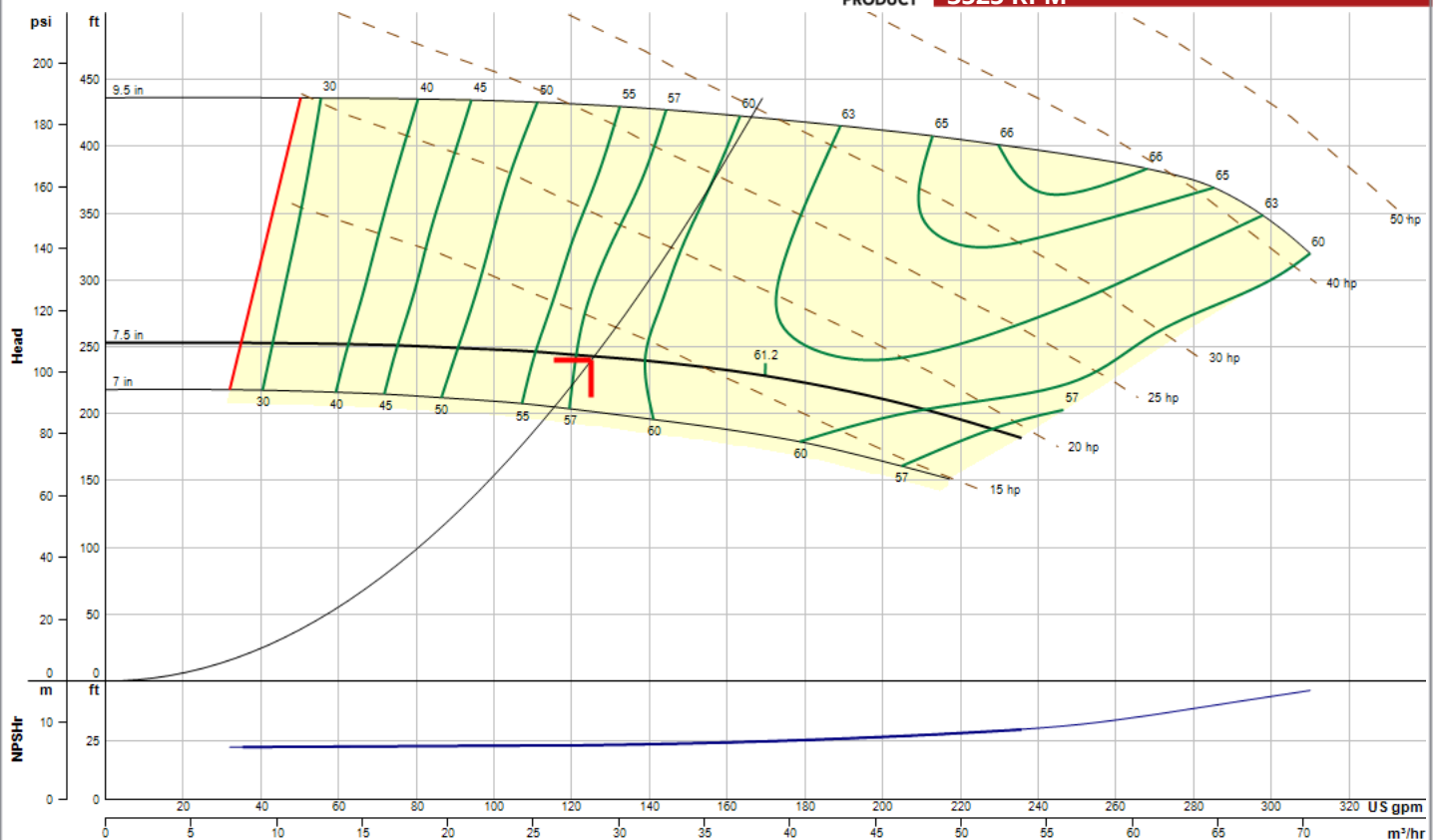

Performance curve meets 14.6 / ISO 9906 acceptance criteria

WIZE-6A20CE

Cooling Tower Systems, Inc.

196 Lower Cherry Street Macon, GA 31201
TF: 800.752.1905 F: 478.755.8304 www.coolingtowersystems.com info@coolingtowersystems.com

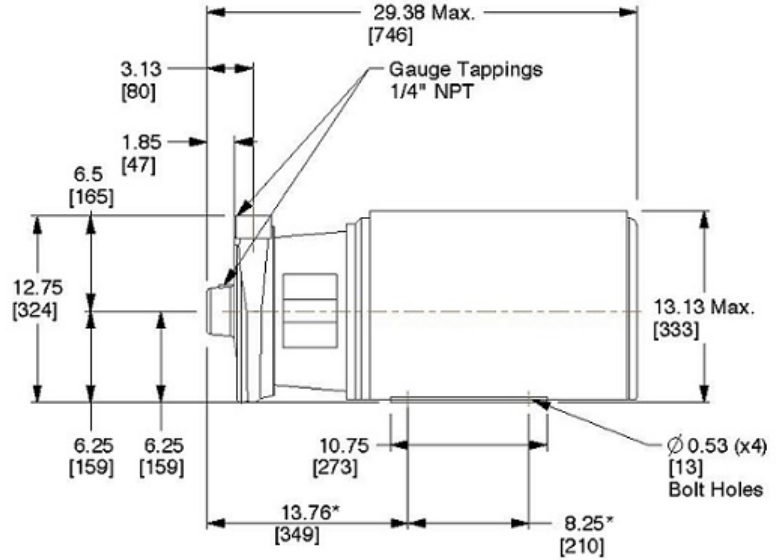
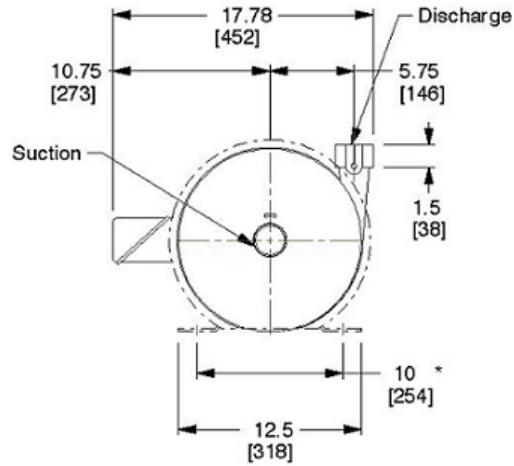

* Dist. Between Bolt Holes



Cooling Tower Systems, Inc.

This drawing and the information depicted therein is the property of Xylem. Copies are issued in strict confidence and shall not be reproduced or copied, or used as the basis for the manufacture or sale of products without prior written permission of Xylem.

Dimensions are subject to change
Not to be used for construction unless certified

BG-E1531-150BC-254-SS

Series e-1531 Close-Coupled Centrifugal Pumps
Motor Frame : 254JM | Seal Type : Standard Seal

Dimensions : IN (mm)

Scale : N.T.S.

Submittal # : B-883.16

Standard Materials of Construction *contact your local rep for optional ES Bearing Frame

Construction:	Stainless Steel Fitted
1 Shaft:	Carbon Steel Grade per Motor Manufacturer
2 Volute:	Cast Iron ASTM A48 Class 30B
3 Impeller:	ASTM A743 Grade CF8 - 304 Stainless Steel
4 Shaft Sleeve:	ASTM 312 Grade TP304 - 304 Stainless Steel
5 Impeller Key:	#304 Stainless Steel
6 Impeller Washer:	Steel
7 Impeller Lock Washer:	#304 Stainless Steel
8 Impeller Cap Screw:	#304 Stainless Steel
9 Volute Gasket:	Cellulose Fiber

Pump Options *contact your local rep to configure

Stainless Steel Volute Wear Ring	Stuffing Box Configuration
External Flush Line	Epoxy Coated Internal Cast Iron Components
Certified Performance Tests (Per HI Standard 14.6)	Special Impeller Balancing (ISO 1940 G2.5 or G1.0)

10 Standard Mechanical Seal Assembly

Elastomer:	Buna
Rotating Face:	Carbon
Stationary Face:	Ceramic
Hardware	Stainless Steel/Brass

Maximum Working Pressure

Max Working Pressure (standard) 175 psi (12 bar) W.P.

