

# TORQUEMASTER PLUS SPRING

## REPLACEMENT INSTRUCTIONS

- SPRING REMOVAL Page 2
- SPRING INSTALLATION Page 4
- FAQS & TIPS Page 8

### Tools Required

WD-TMSPLUS-INST

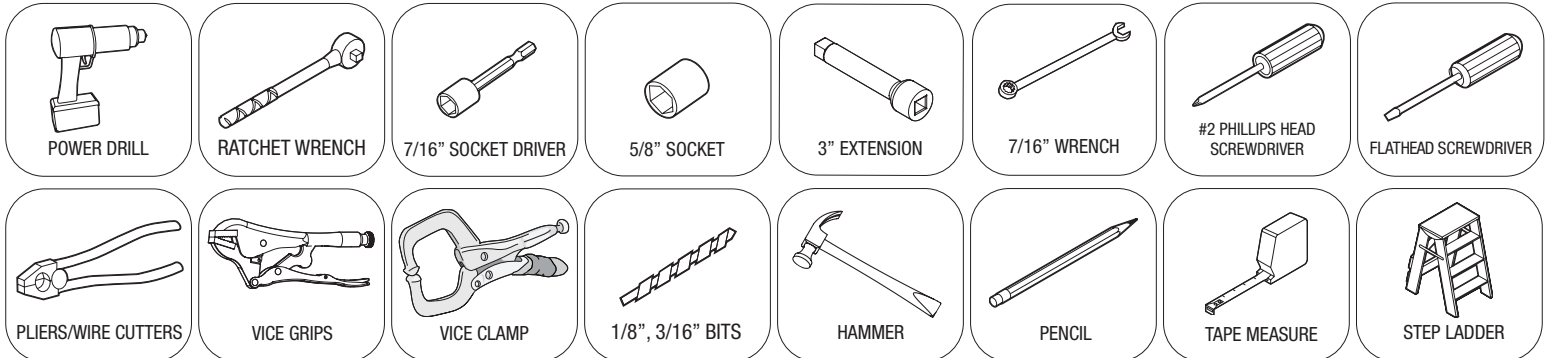

### Pre-Install

- 1 The left hand spring winding cone will be red or marked with a red slash of paint. The right hand spring cone will be gray or silver. Side is determine from inside garage looking out.
- 2 Save the plastic sleeves from your old springs to reuse. Trim to fit your new springs. This is a noise dampener.

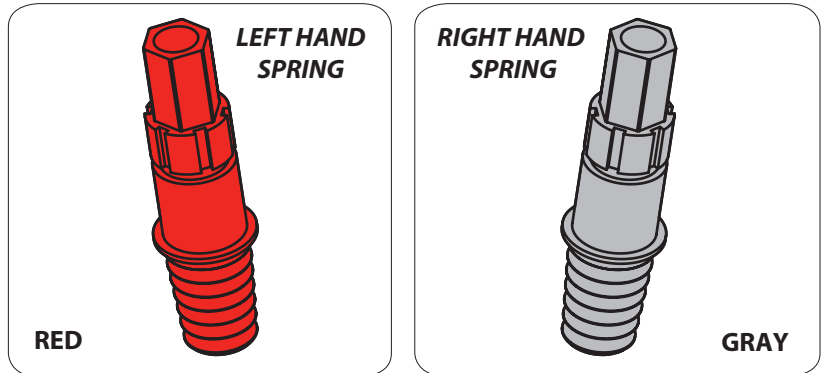

### Spring Looks Different

Spring manufacturing has changed, so there may be some differences as outlined below. This is **NORMAL**.

- 1 Springs may be a different **length** (can be up to a foot shorter), **diameter**, or **wire size** than your old springs. This is due to changes in the manufacturing process.
- 2 Did your old spring have an inner rod and the new ones don't? That's normal too! Due to manufacturing changes, some spring sizes don't need the inner rod now. If your spring needs it, it will come pre-installed that way.
- 3 Spring pairs may also be different lengths than each other. This is the way they are designed to work together.

You can go ahead and install your new springs!

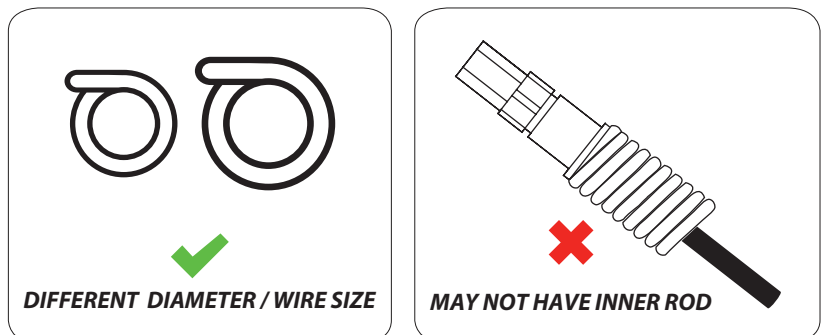
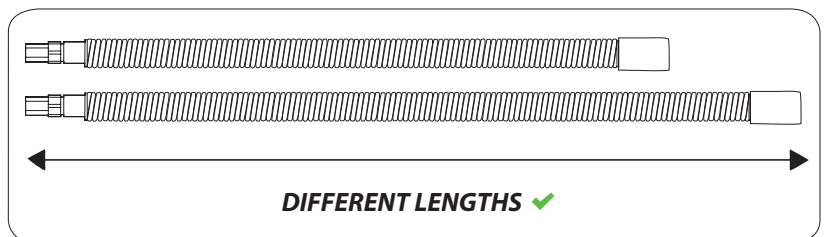

**ATTENTION:** The installation of this product can be dangerous. A powerful spring releasing energy suddenly can cause severe, even fatal, injury. If you are unsure of how to properly install this product, please consult a local Wayne Dalton garage door dealer.

# SINGLE AND DOUBLE SPRING - REMOVAL INSTRUCTIONS

**IMPORTANT!** RIGHT AND LEFT HAND IS ALWAYS DETERMINED FROM INSIDE GARAGE LOOKING OUT. SPRING TENSION MUST BE RELEASED BEFORE REMOVING ANY HARDWARE

## Step 1

Remove drum wraps from cable drums (if installed). Twist the drum wrap while pulling it away from the drum (**Fig. 1.1**)

Check for spring tension by pulling the cable on the right hand cable drum away from garage door (**Fig. 1.2**)

If there is no spring tension, the cable will be loose and the spring tube should rotate freely. If loose, proceed to **Step 3**. If cable isn't loose and spring tube is difficult to rotate, proceed to **Step 2**.

## Step 2

Starting with right hand side, place pawl knob in upper position to remove spring tension (**Fig. 1.3**)

Place a ratchet with a 5/8" socket (3" extension for clearance as needed) on winding shaft (**Fig. 1.4**). Ensure ratchet and socket are set to add tension: Counterclockwise on right side and clockwise on left side.

Rotate ratchet to release pressure between pawl and end bracket inner gear. Push in on pawl to allow gear teeth to pass by.

Be prepared to hold the full tension of the spring. Gently let ratchet rotate upward, while watching the number of teeth on inner gear pass by pawl. Remove 1/4 turn at a time.

Release pawl to engage with the inner gear. Repeat this process until all spring tension has been removed from spring. For Double Springs, repeat on left side. Cables should be loose and spring tube should rotate freely.

- 6'-0" Door Height = 14 turns
- 6'-3" Door Height = 14 1/2 turns
- 6'-6" Door Height = 15 turns
- 6'-9" Door Height = 15 1/2 turns
- 7'-0" Door Height = 16 turns
- 7'-3" Door Height = 16 1/2 turns
- 7'-6" Door Height = 17 turns
- 7'-9" Door Height = 17 1/2 turns
- 8'-0" Door Height = 18 turns

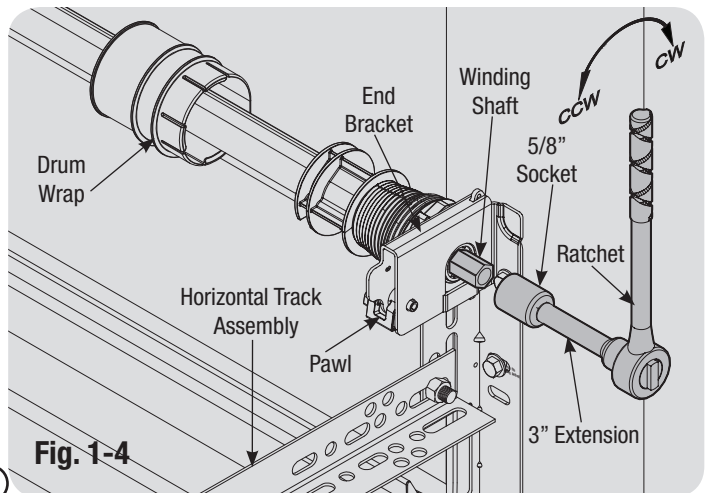
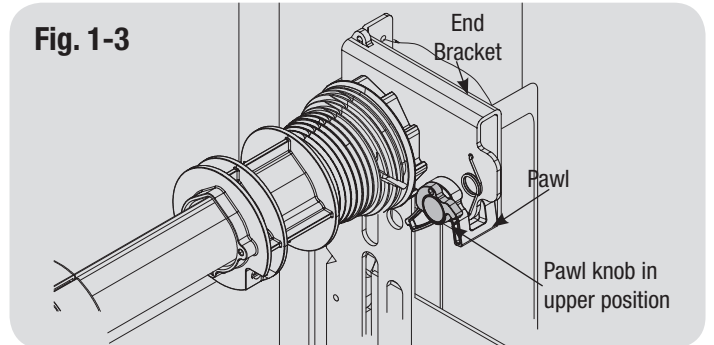
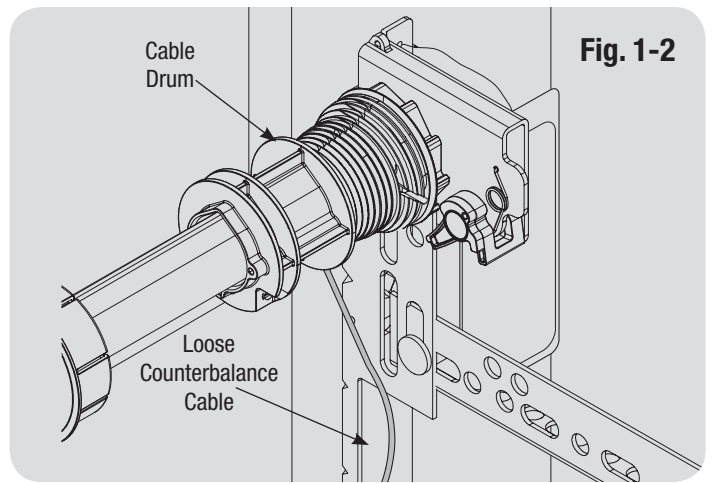
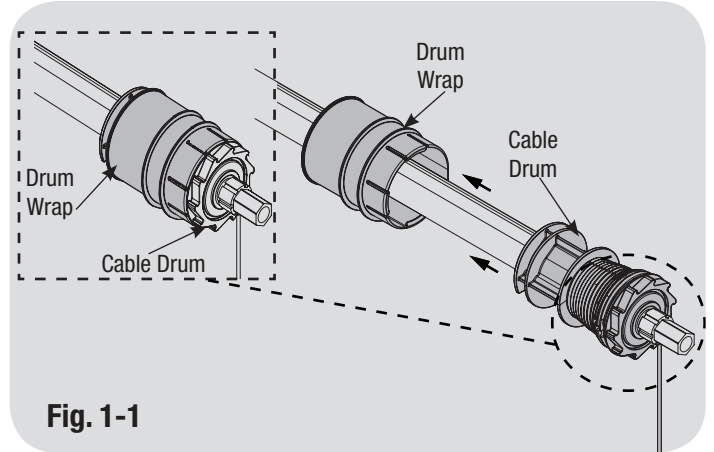

## Step 3

**IMPORTANT:** Single springs with idler bracket **FIG 2.1** (left side): Idler bracket cannot be removed from the left hand cable drum. Idler bracket may break if your try to remove it.

### STANDARD & LOW HEADROOM - FRONT MOUNT:

Start with right bracket. Remove carriage bolt and hex nut, then remove lag screw. **FIG 1.5**

1

### STANDARD & LOW HEADROOM - REAR MOUNT:

Start with right bracket. Remove track bolt and nut. Then remove shim, hex head screw and nut. **FIG 1.6 & FIG 1.7 - DO NOT DISCARD SHIM**

2

Hold bracket with locking pliers and carefully pry away from flagangle/rear support bracket and winding shaft with flat head screwdriver **FIG 1.8**. Repeat for left side.

3

### FOR SINGLE SPRING WITH IDLER BRACKET:

On left hand side, remove track bolt, flat washer (if applicable) and flange hex nut. Next, remove hex head screw and nut from the idler bracket. **FIG 2.1**

4

Take note how many times cable has been wrapped around drum to duplicate later. Cable drums require either 1/2 - 3/4 wraps or 1 1/2 - 1 3/4 wraps.

5

Bend center bracket tab over **FIG 1.9**. Lift right side of tube and slide cable drum off. If drums or springs are hard to remove, twist them to aid removal.

6

Realign groove in winding shaft with round notch in flag angle / rear support bracket and drape cable with drum over the flag angle / rear support bracket **FIG 2.0**. Repeat for other side.

7

Lay tube on floor and remove all contents including plastic sleeve, rod, and spring pieces. Tube should be completely empty and free of debris.

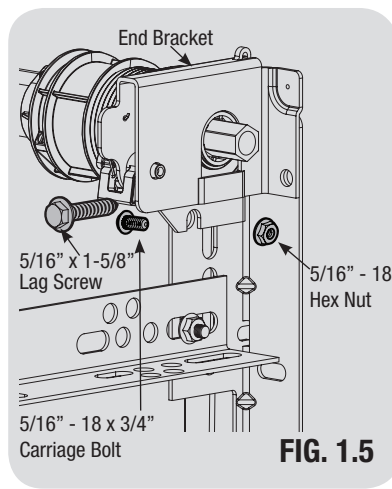

**FIG. 1.5**

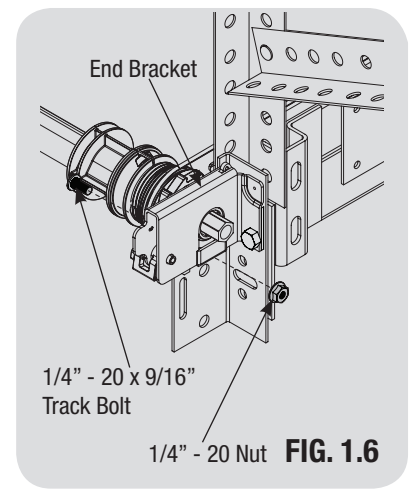

**FIG. 1.6**

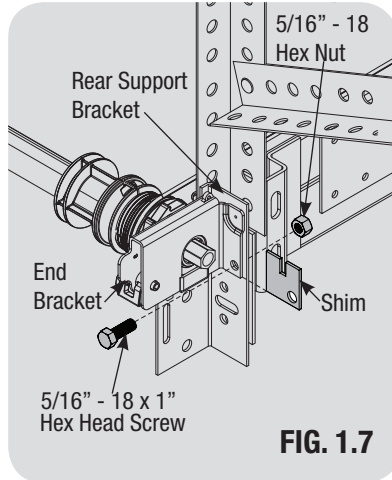

**FIG. 1.7**

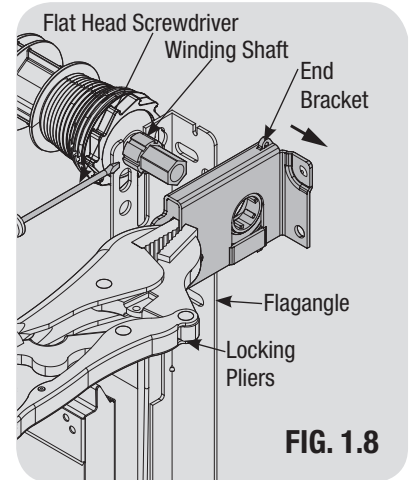

**FIG. 1.8**

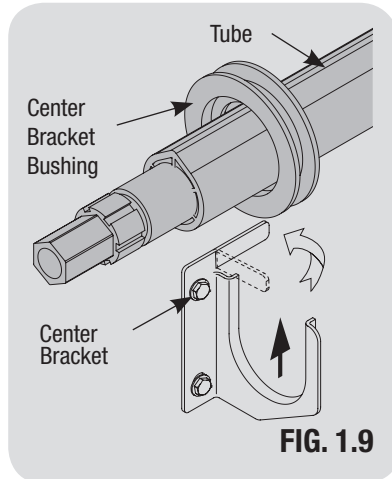

**FIG. 1.9**

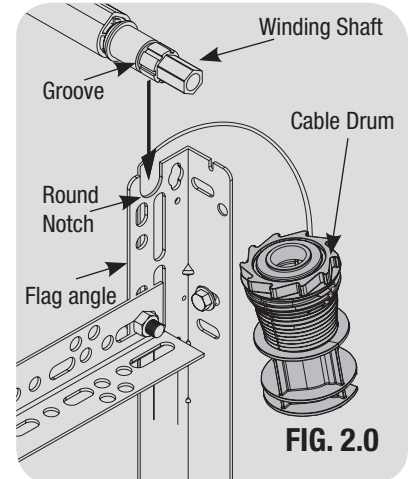

**FIG. 2.0**

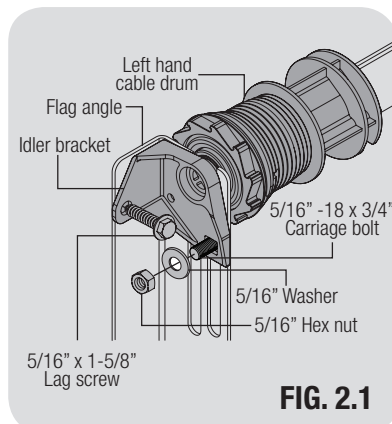

**FIG. 2.1**

# SINGLE AND DOUBLE SPRING - INSTALLATION INSTRUCTIONS

**IMPORTANT!** RIGHT AND LEFT HAND IS ALWAYS DETERMINED FROM INSIDE GARAGE LOOKING OUT.

## Step 1

Slide new spring(s), perch end first, into spring tube, **FIG 2.2**. For single spring applications, there will be no left hand spring inserted into the spring tube assembly. Instead you will install the idler bracket (in future steps).

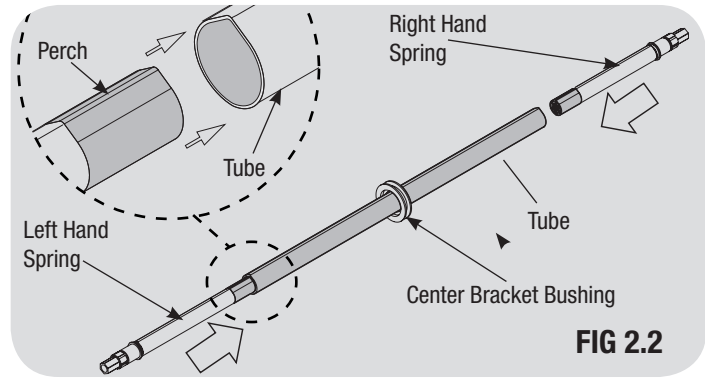

## Optional Drum Wraps

If you don't have drum wraps (optional), then skip this step. Drum wraps are only required on Rear Mount Low Headroom setups.

Drum wraps must be installed prior to installing the end bracket. The drum wraps are side specific as pictured - **FIG 2.3**.

Slide left drum wrap over left side spring tube with tabs facing left. Slide right hand drum wrap over right side of spring tube with tabs facing right.

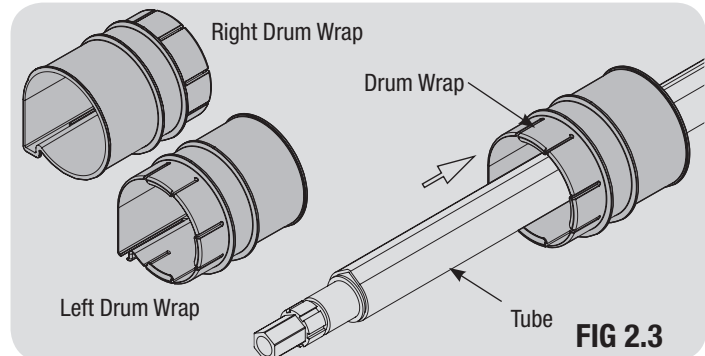

## Step 2 - Cable Drums

1 Shake the spring tube gently to extend the winding shafts out about 5" on each side. Align the center bushing into the center bracket. Check tube for level and adjust if necessary. Bend center bracket tab back over center bushing - **FIG. 2.4**

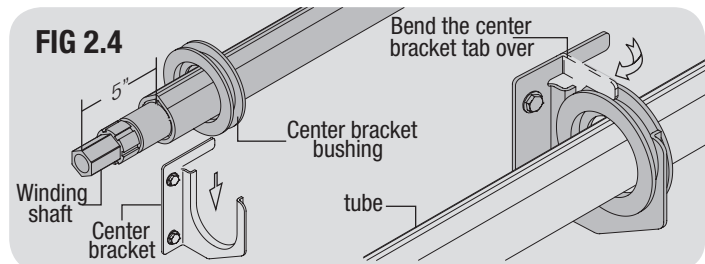

2 Winding shaft must extend past cable drum far enough to expose splines and groove. Align winding shaft groove with round notch in flag angle / rear support bracket. Adjust cable drum by rotating to match previous settings. Prewrap cable 1-1/2 turns - **FIG. 2.5**

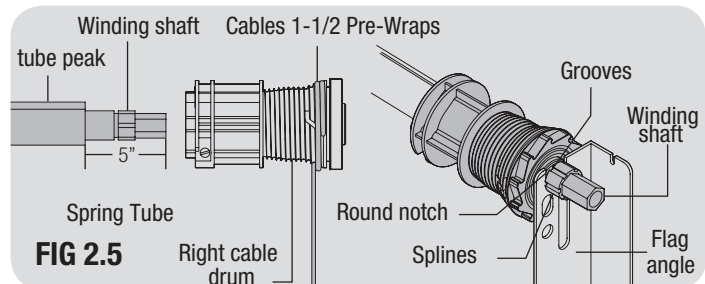

3 **STANDARD & LOW HEADROOM - FRONT MOUNT:**  
Starting on right side, position spring tube so that tube tear drop shaped peak is pointing straight up.

3 **STANDARD & LOW HEADROOM - REAR MOUNT:**  
Starting on right side, position spring tube so that tube tear drop shaped peak is pointing towards the door sections.

4 Cable drums and spring tube are tear drop shaped to fit together only one way. Slide the correct cable drum over the winding shaft until it seated against tube - **FIG 2.5**

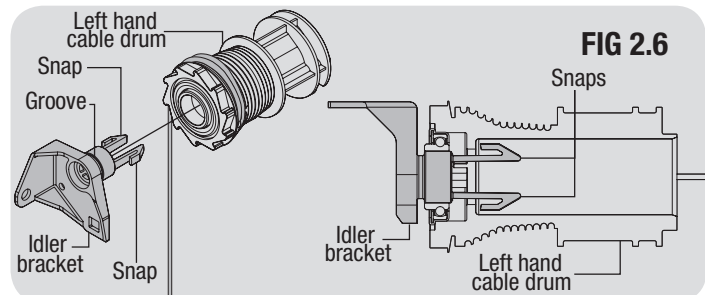

**For Double Springs:** Repeat above steps for left side.

5 **For Single Springs:** Insert idler bracket into left cable drum. Lightly press idler bracket into cable drum until two distinct clicks are heard, or bracket is inserted all the way - **FIG 2.6**

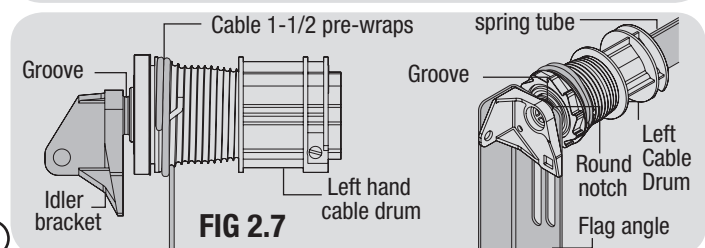

Slide spring tube into cable drum until seated against tube. Align idler groove with round notch in flag angle / rear support bracket

## Step 3 - End Brackets

You can identify the right bracket by the cable guide - **FIG 2.8**

**NOTE:** If ratchet wheel falls out of end bracket, ensure teeth on ratchet wheel are pointing upward in a clockwise position when sliding it back inside bracket - **FIG 2.9**

### STANDARD & LOW HEADROOM - FRONT MOUNT:

Starting with right side, slide end bracket onto winding shaft so splines in ratchet wheel fit onto winding shaft grooves - **FIG 2.8**  
Attach end bracket to flag angle with carriage bolt, washer and hex nut. Then secure end bracket to jamb using lag screw **FIG 2.9**

**NOTE:** Prior to fastening the end bracket(s) / idler bracket to door jamb, drill a pilot hole using a 3/16" drill bit. Punch hole in flag angle / rear support bracket as needed for carriage bolt if hole not located in correct position **FIG 2.9**

### STANDARD & LOW HEADROOM - REAR MOUNT:

On right side, slide end bracket on winding shaft so ratchet wheel fits on winding shaft grooves. Slide shim (as needed) between end bracket and rear support bracket. Attach end bracket to rear support bracket and reinforcing bracket (if applicable) using hex head bolt and hex nut. Secure end bracket to rear support bracket using track bolt, flat washer and hex nut - **FIG 3.0**

**FOR DOUBLE SPRINGS:** Repeat above steps for left side.

**FOR SINGLE SPRING:** Make sure left hand cable drum bearing is snug up against flag angle. If drum is pulled away from flag angle, then idler bracket can rub cable drum causing noise.

Secure the idler bracket to the flag angle / rear support bracket using carriage bolt, washer hex nut. Then secure idler bracket to jamb using lag screw - **FIG 3.1** or **FIG 3.2**

**IMPORTANT:** If flag angle / rear support bracket doesn't have a slot for the tab on end bracket - break tab off so end bracket can sit flush. **FIG 3.3**

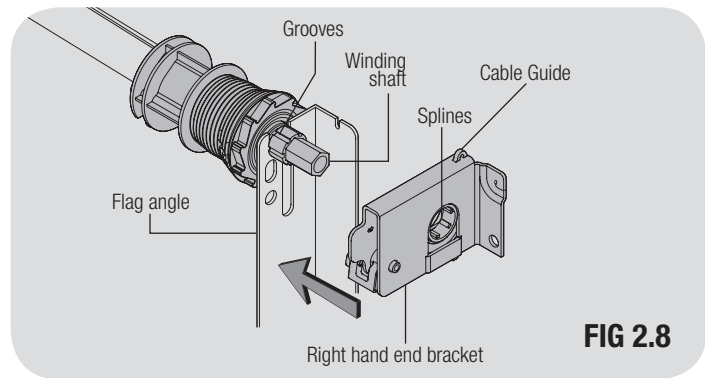

**FIG 2.8**

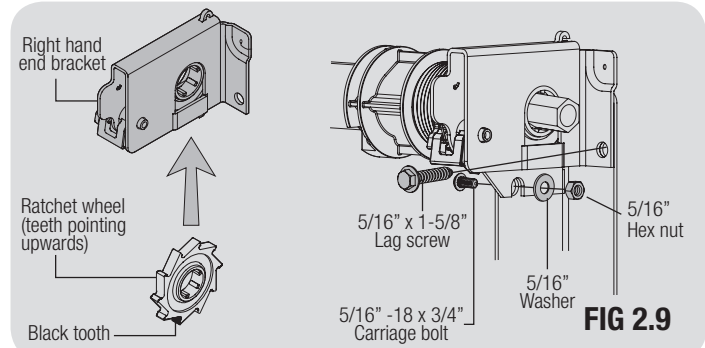

**FIG 2.9**

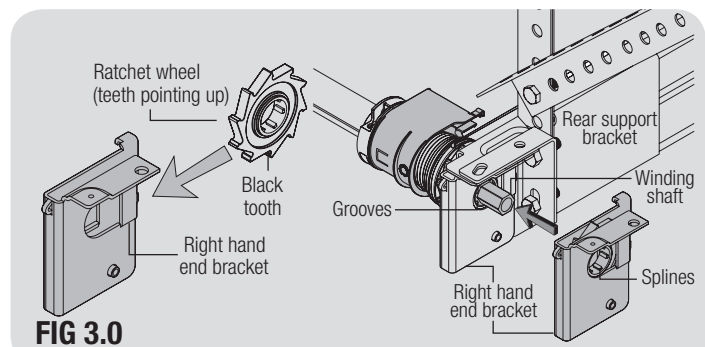

**FIG 3.0**

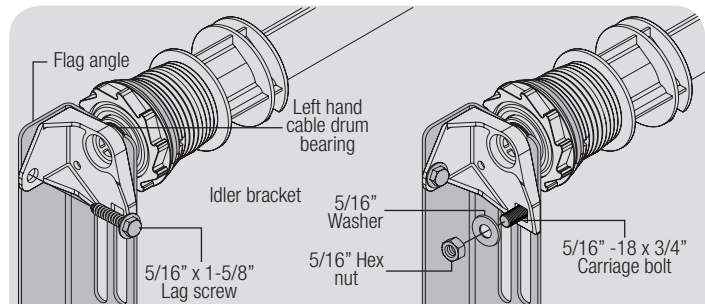

**FIG 3.1**

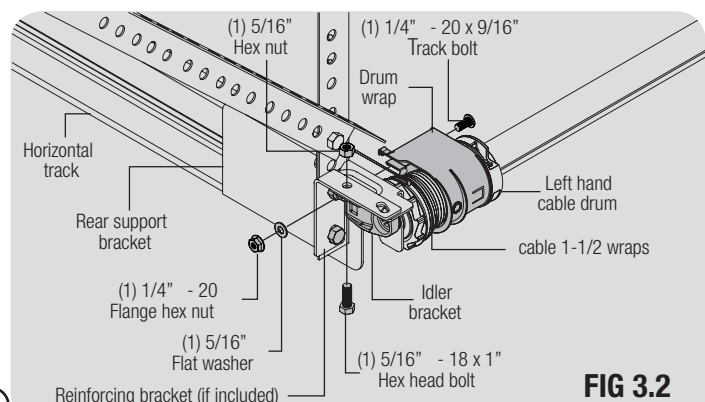

**FIG 3.2**

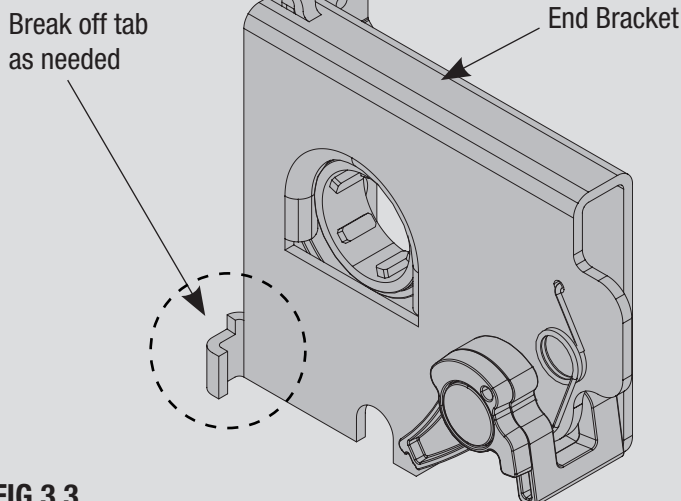

**FIG 3.3**

## Step 4 - Cable Adjustments

### STANDARD & LOW HEADROOM - FRONT MOUNT:

Start on right side. Adjust drum by rotating drum until set screw faces directly away from header. Peak of spring tube should be pointing straight up - **FIG 3.4**

1

### STANDARD & LOW HEADROOM - REAR MOUNT:

Start on right side. Route cable over drum and adjust drum by rotating drum until set screw is pointing towards ceiling. Peak of spring tube should be pointing towards door sections - **FIG 3.5**

2

Loosen the set screw no more than 1/2 turn. Ensure cable is aligned and seated in first and second grooves of cable drum. Pull end of cable to remove all cable slack and ensure cable tension is equal on both sides of door.

3

Snug the set screw and tighten additional 1-1/2 turns. Measure approximately 6" of cable and cut off excess. Insert end of cable into hole on cable drum. Repeat for left hand cable drum.

FIG 3.4

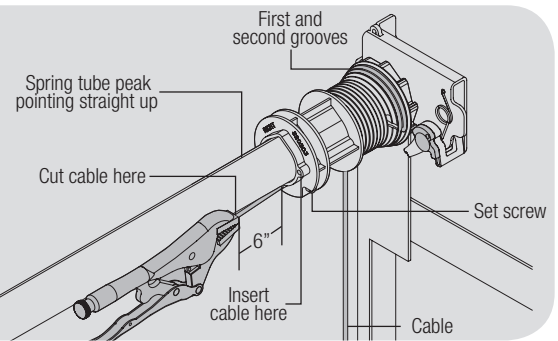
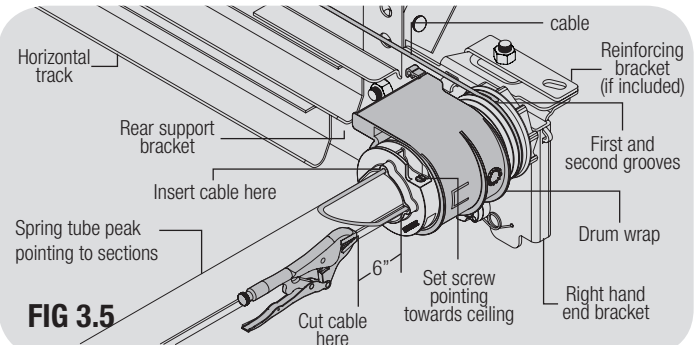
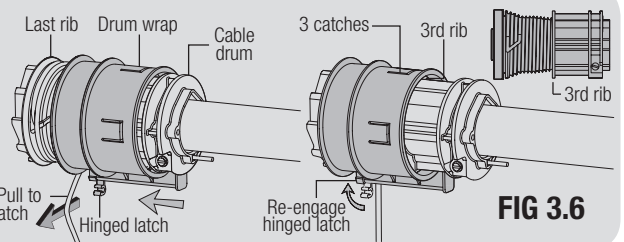

FIG 3.5



## OPTIONAL DRUM WRAPS

If you don't have drum wraps, skip this step. Position left drum wrap. Slide left drum wrap over cable drum assembly. Pull cable to clear latch, and slide drum wrap against last rib until three catches engage 3rd rib. Secure hinge latch by rotating upward until a distinct snap is felt. Confirm catch is fully engaged by lightly tugging on it. Repeat for right side - **FIG 3.6**



## Step 5 - Winding Springs

1

Place vice clamps on both vertical tracks just above third roller to prevent door from raising while winding springs. Double check cable is aligned in first and second grooves of drums. Mark on winding shaft (or socket) and end bracket to count turns - **FIG 3.7**

2

Start on right side. Turn pawl knob on end bracket to the upper position. Use a ratchet wrench with 5/8" socket (3" extension if needed) on winding shaft to wind spring. Rotate winding shaft counter clockwise. Watch mark to count turns.

3

After 2 to 3 turns, remove ratchet wrench and adjust cable on left side. Ensure cables are in first and second grooves on drums and equally tensioned on both sides before fully winding springs.

**FOR SINGLE SPRING:** Return to the right hand end bracket and continue winding to required turns for door. Place pawl knob in lower position. **NOTE:** Singles require no spring winding on left side, but cable tension needs to be adjusted.

4

**FOR DOUBLE SPRINGS:** Place ratchet on left winding shaft and rotate clockwise. Watch mark on winding shaft to count turns. Rotate winding shaft to required turns for door. Then return to right side and wind to required turns. Place pawl knob in lower position on both sides.

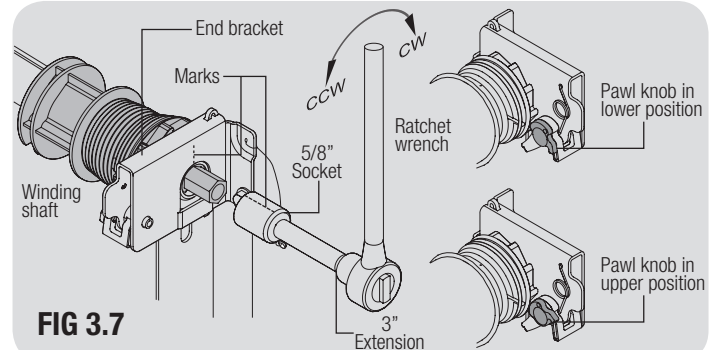

FIG 3.7

WINDING SPRING TURN CHART

DOOR HEIGHT	SPRING TURNS
6'-0"	14
6'-3"	14-1/2
6'-5"	15
6'-6"	15
6'-8"	15-1/2
6'-9"	15-1/2
7'-0"	16
7'-3"	16-1/2
7'-6"	17
7'-9"	17-1/2
8'-0"	18

**IMPORTANT:** Total turns to balance door may be different from suggested chart values above. Make adjustments  $\pm 1/4$  turn on each side as needed until door is balanced.

## Step 6 - Balancing Door

1

Remove any vice clamps. Lift door and check its balance. Adjust spring(s) if door lifts by itself (hard to pull down) or if door is difficult to lift (easy to pull down). Anytime spring adjustments are made, ratchet pawl knob must be in upper position. An unbalanced door can cause operation problems.

2

Place vice clamps on both vertical tracks just above third roller to prevent door from raising while winding springs.

**IMPORTANT:** When adjusting only add or remove 1/4 turn (three teeth on ratchet wheel) at a time. Both sides need to be adjusted equally on double spring doors.

**Add spring tension:** Ensure ratchet and socket is set so it will tighten counter clockwise on right side and clockwise on left side. Place pawl knob in upper position. Place ratchet wrench with 5/8" socket (3" extension if needed) on winding shaft, pull down to add 1/4 turn. Watch as three teeth pass over pawl, will click 3 times. Place pawl knob in lower position. Repeat for other side if double spring door.

3

**Remove spring tension:** Place regular 5/8" wrench on winding shaft. Place pawl knob in upper position. Pull down on wrench to relieve pressure between pawl and ratchet wheel. Push in on pawl to allow three ratchet wheel teeth to pass by pawl. Carefully allow wrench to rotate upward, release pawl to engage with ratchet wheel. Place pawl knob in lower position. Repeat for other side if double spring door.

**IMPORTANT:** Be prepared to hold full spring tension.

If door does not operate easily, close door and unwind right hand spring to zero and check the following:

4

1. Check door, spring tube and flag angles for level.
2. Check distance between flag angles, must be door width plus 3-3/8" to 3-1/2"
3. Check cables for equal tension - loosen set screws and adjust.
4. Rewind the spring(s).
5. Make sure door isn't rubbing on jambs

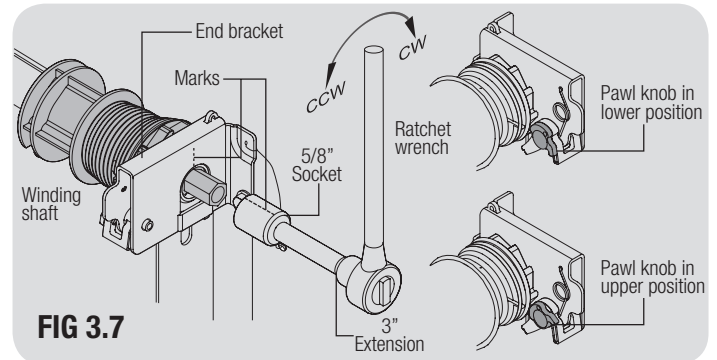

FIG 3.7

WINDING SPRING TURN CHART

DOOR HEIGHT	SPRING TURNS
6'-0"	14
6'-3"	14-1/2
6'-5"	15
6'-6"	15
6'-8"	15-1/2
6'-9"	15-1/2
7'-0"	16
7'-3"	16-1/2
7'-6"	17
7'-9"	17-1/2
8'-0"	18

**IMPORTANT:** Total turns to balance door may be different from suggested chart values above. Make adjustments  $\pm 1/4$  turn on each side as needed until door is balanced.

# FAQS & TIPS

## **Why is the spring I received much shorter than my old spring?**

The torquemaster springs you receive will not always match the length of your old springs due to the switch from an oil tempered spring to a new high tensile strength music wire spring. It may be different in length, diameter, or wire size than your existing spring, but it is the correct part that you ordered for the size of your garage door.

## **The springs I received are too short for the width of my door. How do I connect it on the inside?**

The springs you received are what is rated for the height and weight of your door as ordered. The width of your door is not a factor because Torquemaster springs are self anchoring to expand and contract inside the spring tube. There must be empty space inside the tube for this to happen. Torquemaster spring tubes are teardrop shaped. The anchor cone on the end of the spring that goes inside the tube is also teardrop shaped. This design allows the anchor cone to lock into place when wound to provide the tension needed to lift and lower your door. As this happens the spring coils will stretch and contract. You do not connect the inside cone with anything inside the tube. Make sure your spring tube is completely empty before installing.

## **My old spring had a rod inside of it and the new spring doesn't. What do I do with this part?**

You can safely discard the rod and any broken spring pieces found inside your spring tube. Some of the newer springs no longer require an inner rod. If all the information you provided when ordering is correct, the spring that you receive will be the spring currently manufactured for your garage door.

## **My new spring didn't come with plastic sleeves. What do I do?**

You can reuse your old spring sleeves. Just remove them from the spring tube, trim them down to fit inside the cones on your new spring, slide onto new spring prior to reinstalling spring in tube. Don't have the sleeves anymore? That's ok. The spring sleeves only serve as a noise dampener and springs can be installed without them.

## **The end bracket won't sit flush against the flag angle / rear support bracket. How can I install properly?**

If flag angle / rear support bracket doesn't have a slot for the tab on end bracket - break tab off so end bracket can sit flush. **FIG 3.3**

## **The holes on the end bracket don't line up with the holes/slots in my flag angle / rear support bracket. How can I install properly?**

Prior to fastening the end bracket(s) / idler bracket to door jamb, drill a pilot hole using a 3/16" drill bit. Punch hole in flag angle / rear support bracket as needed for carriage bolt if hole not located in correct position **FIG 2.9**