



Trolley Arm Attachment / Operator Bracket

Models: 9100, 9600, 5120, 5140

Installation Instructions Insert

Wayne-Dalton, a Division of Overhead Door Corporation
 P.O. Box 67, Mt. Hope, OH 44660
 www.Wayne-Dalton.com

Use this insert in conjunction with your door's Installation Instructions and Owner's Manual.

1

OPERATOR BRACKET

NOTE: Operator bracket must be mounted and secured prior to installing top section.

IMPORTANT! WHEN CONNECTING A TROLLEY TYPE GARAGE DOOR OPENER TO THIS DOOR, A WAYNE-DALTON OPENER / TROLLEY BRACKET MUST BE SECURELY ATTACHED TO THE TOP SECTION OF THE DOOR, ALONG WITH ANY U-BARS PROVIDED WITH THE DOOR. THE INSTALLATION OF THE OPENER MUST BE ACCORDING TO MANUFACTURER'S INSTRUCTIONS AND FORCE SETTINGS MUST BE ADJUSTED PROPERLY.

Prior to installing top section, locate the center of the top section and seat the operator bracket on male part of top section, align the center of both tabs of the bracket with the section's center line.

For retro fit applications, the operator bracket must be aligned with an existing operator and positioned on top section so it bridges the transition point of the section thickness, as shown in FIG. 1.1 and 1.2.

Install (2) #12 x 1/2" phillips head screws on the opposite side of operator bracket, as shown in FIG. 1.3.

Install top section at this time. Secure u-bar (if furnished) using 1/4" - 20 x 11/16" self-drilling screws as instructed in the door manual and then clamp operator bracket to u-bar, as shown in FIG. 1.4.

First attach (3) 1/4" - 14 x 5/8" self-tapping screws to the operator bracket, as shown in FIG. 1.5.

Then attach (2) 1/4" - 14 x 5/8" self-tapping screws to the operator bracket, as shown in FIG. 1.6. Remove vice clamps.

NOTE: If you have a 9100 door, you can use two of the 1/4" - 20 x 11/16" self-drilling screw used to attach the u-bar instead of the 1/4" - 14 x 5/8" self-tapping screw when attaching operator bracket to u-bar, as shown in FIG. 1.6.

NOTE: When attaching operator bracket to top section with u-bar, apply additional pressure to thread the fasteners into the u-bar.

NOTE: See FIG. 1.7 for installing operator bracket on top section without u-bars.

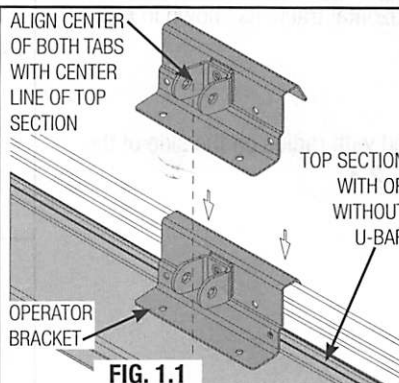

FIG. 1.1

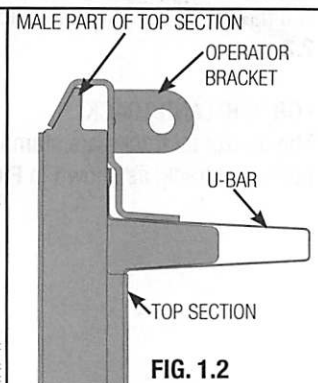

FIG. 1.2

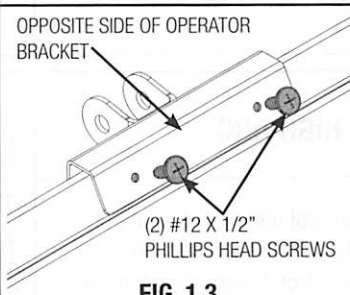

FIG. 1.3

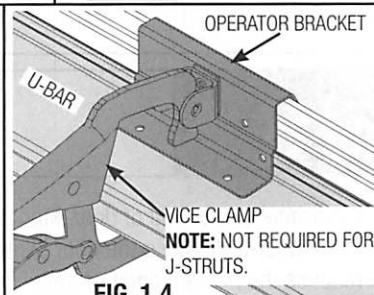

FIG. 1.4

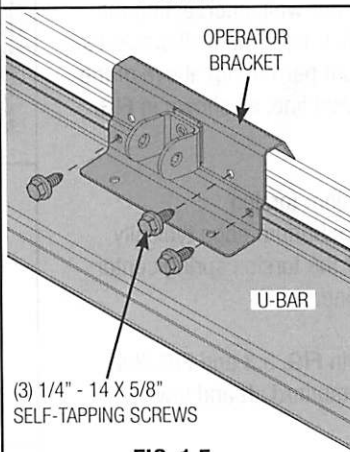

FIG. 1.5

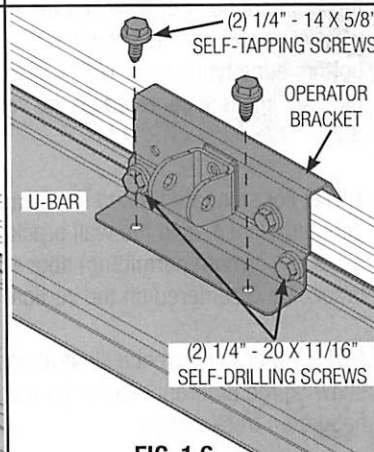

FIG. 1.6

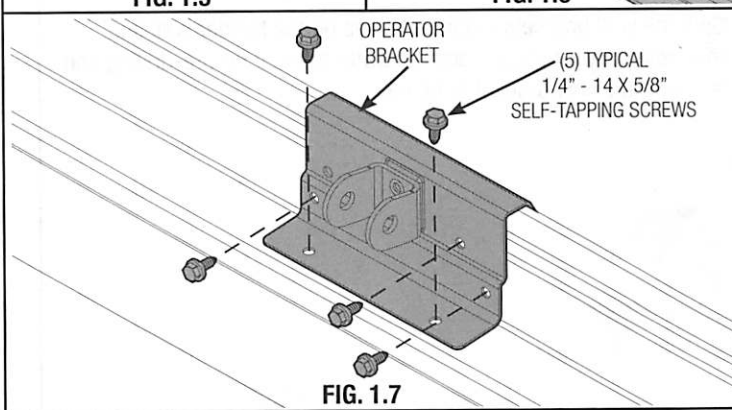

FIG. 1.7

2

IDENTIFY TRACK RADIUS

NOTE: If you have a low headroom track system (FIG. 2.1), proceed to Step 3.

DETERMINE THE WAYNE-DALTON TRACK RADIUS BEING USED:

FOR MOUNT HOPE AND PENSACOLA TRACK:

Measure the curved ends of the horizontal track to determine if you have a 12" or 15" radius horizontal track, as shown in FIG. 2.2.

FOR PORTLAND TRACK:

The horizontal tracks are stamped with radius on the side of the horizontal track, as shown in FIG. 2.3.

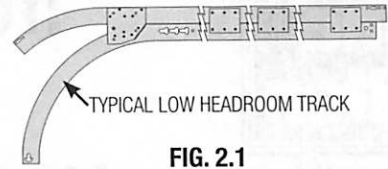

FIG. 2.1

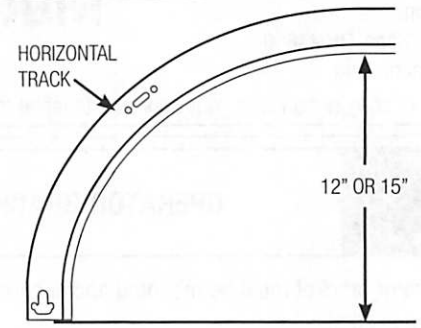

FIG. 2.2

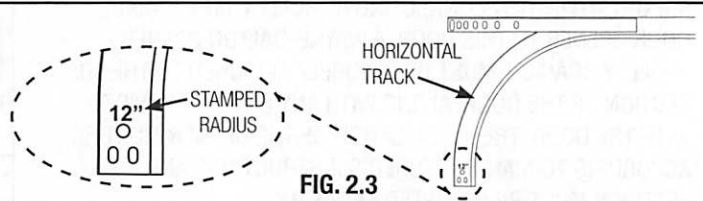

FIG. 2.3

3

HIGH ARC

Determine center line of door. Mark vertical line at this point, on the header wall. Raise the door slightly until the top section reaches the highest point of travel (high arc). Using a level, mark this high arc point of travel on the header wall, intersecting the vertical center line, as shown in FIG. 3.1. Hold the wall bracket's bottom edge typically to 1/2" - 1" (room permitting) above of the high arc line and centered on the vertical line, as shown in FIG. 3.2.

NOTE: For standard lift and low headroom torsion counterbalance, hold the wall bracket's bottom edge typically a 1/2" - 1" (room permitting) above of the torsion spring center bracket and centered on the vertical line.

NOTE: Refer to reference illustrations in FIG. 3.3 and FIG. 3.4, showing the difference between the standard lift and low headroom track system.

Spot the wall brackets mounting holes on the header wall and then refer to your garage door operator manual for pre-drilling and securing the wall bracket to header.

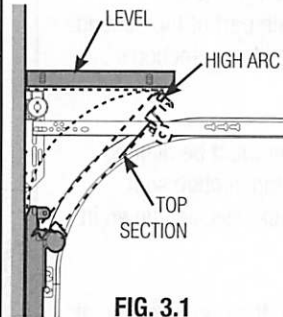

FIG. 3.1

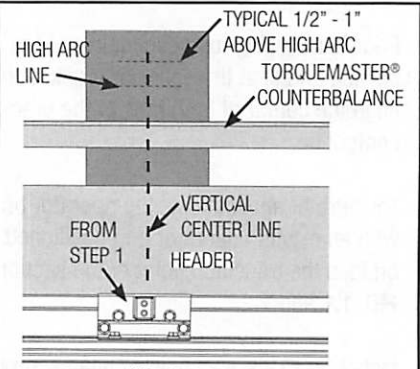

FIG. 3.2

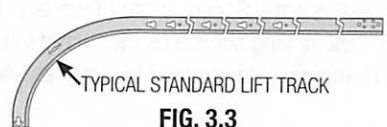

FIG. 3.3

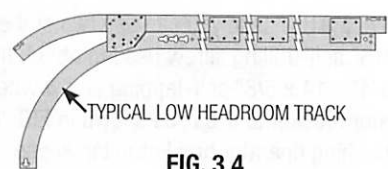

FIG. 3.4

4

OPERATOR HOOK-UP

Using the OPERATOR HOOK-UP CHARTS, refer to referenced illustrations in FIG. 4.1 through FIG. 4.3 for correct arm hook-up from trolley to operator bracket.

NOTE: Refer to your operator manual for specific details on how to assembly the curved and straight arm, as shown in FIG. 4.1 through FIG. 4.3.

NOTE: Depending on your setup, you may have to cut straight arm to accomplish trolley settings, as shown in FIG. 4.1 through FIG. 4.3.

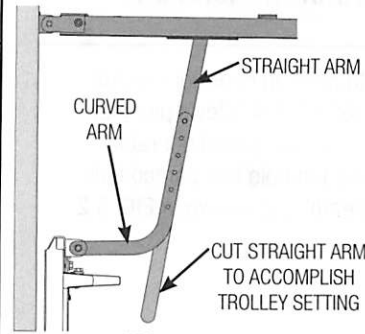

FIG. 4.1

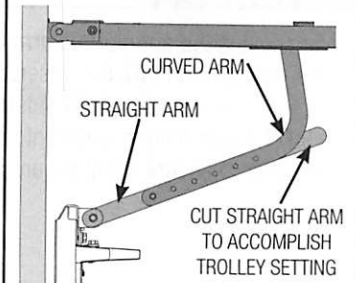

FIG. 4.2

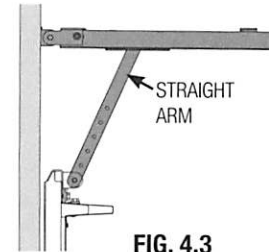

FIG. 4.3

TORQUEMASTER® AND EXTENSION SPRINGS

OPERATOR HOOK-UP CHART STANDARD LIFT FOR 10" AND 12" RADIUS

OPERATOR MODELS	TYPE OF ARM BEING USED	REF. ILLUSTRATIONS ABOVE
QUANTUM/CLASSIC	CURVED / STRAIGHT	FIG. 4.2
LINEAR	STRAIGHT / CURVED	FIG. 4.1
LIFTMASTER (SEARS)	CURVED / STRAIGHT	FIG. 4.2
GENIE	CURVED / STRAIGHT	FIG. 4.2

OPERATOR HOOK-UP CHART STANDARD LIFT FOR 14" AND 15" RADIUS

OPERATOR MODELS	TYPE OF ARM BEING USED	REF. ILLUSTRATIONS ABOVE
QUANTUM/CLASSIC	CURVED / STRAIGHT	FIG. 4.2
LINEAR	STRAIGHT / CURVED	FIG. 4.1
LIFTMASTER (SEARS)	CURVED / STRAIGHT	FIG. 4.2
GENIE	CURVED / STRAIGHT	FIG. 4.2

TORSION SPRINGS

OPERATOR HOOK-UP CHART STANDARD LIFT FOR 10" AND 12" RADIUS

OPERATOR MODELS	TYPE OF ARM BEING USED	REF. ILLUSTRATIONS ABOVE
QUANTUM/CLASSIC	STRAIGHT / CURVED	FIG. 4.1
LINEAR	STRAIGHT / CURVED	FIG. 4.1
LIFTMASTER (SEARS)	CURVED / STRAIGHT	FIG. 4.2
GENIE	STRAIGHT	FIG. 4.3

OPERATOR HOOK-UP CHART STANDARD LIFT FOR 14" AND 15" RADIUS

OPERATOR MODELS	TYPE OF ARM BEING USED	REF. ILLUSTRATIONS ABOVE
QUANTUM/CLASSIC	STRAIGHT / CURVED	FIG. 4.1
LINEAR	STRAIGHT / CURVED	FIG. 4.1
LIFTMASTER (SEARS)	CURVED / STRAIGHT	FIG. 4.2
GENIE	CURVED / STRAIGHT	FIG. 4.2

OPERATOR HOOK-UP CHART FOR LOW HEADROOM

OPERATOR MODELS	TYPE OF ARM BEING USED			
	PREFERRED HOOKUP	REF. ILLUSTRATIONS ABOVE	OPTIONAL HOOKUP	REF. ILLUSTRATIONS ABOVE
QUANTUM/CLASSIC	CURVED / STRAIGHT	FIG. 4.2	STRAIGHT	FIG. 4.3
LINEAR	STRAIGHT	FIG. 4.3	N/A	N/A
LIFTMASTER (SEARS)	CURVED / STRAIGHT	FIG. 4.2	STRAIGHT	FIG. 4.3
GENIE	CURVED / STRAIGHT	FIG. 4.2	STRAIGHT	FIG. 4.3

OPERATOR HOOK-UP CHART FOR LOW HEADROOM

OPERATOR MODELS	TYPE OF ARM BEING USED			
	PREFERRED HOOKUP	REF. ILLUSTRATIONS ABOVE	OPTIONAL HOOKUP	REF. ILLUSTRATIONS ABOVE
QUANTUM/CLASSIC	CURVED / STRAIGHT	FIG. 4.2	STRAIGHT	FIG. 4.3
LINEAR	CURVED / STRAIGHT	FIG. 4.2	STRAIGHT	FIG. 4.3
LIFTMASTER (SEARS)	CURVED / STRAIGHT	FIG. 4.2	STRAIGHT	FIG. 4.3
GENIE	CURVED / STRAIGHT	FIG. 4.2	STRAIGHT	FIG. 4.3

5

DOOR ARM ATTACHMENT

Align hole in the appropriate arm with holes in operator bracket tabs, as shown in FIG. 5.1. Insert 5/16" x 1-1/4" clevis pin, making sure hole in clevis pin is outside of second tab of operator bracket. Insert hairpin cotter into clevis pin hole and spread hairpin cotter to ensure it will secure assembly, as shown in FIG. 5.2.

