

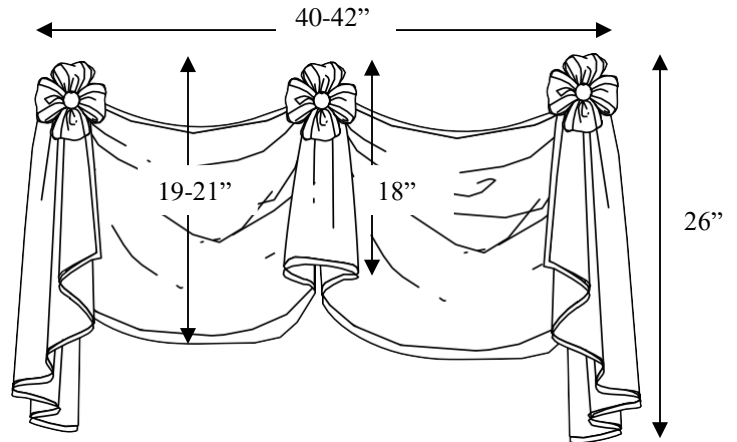

## MORRISON VALANCE

©2003 Pate-Meadows Designs, Inc. (Rev. 10/13)

- This unique valance is a casual take on a formal style and can be adapted to fit any size window by adding additional swag sections. Our instructions are for a valance that is 40" to 42" finished width. The information needed to add to or reduce the width is included. The finished length of the valance is approximately 21" at the swag, 18" at the middle jabot and 26" at the side jabots. The valance is trimmed in a bias band out of contrasting fabric.



- This valance works best when constructed out of a medium-weight decorative fabric.
- With drapery interlining, the valance has better shaping and the color of the contrasting fabric does not bleed through to the face fabric when sun shines through the valance. Interlining is a flannel-like cotton fabric that hangs between the face fabric and the lining. It is available in white and natural colors and can be found at most decorative fabric stores or at [www.patemeadows.com](http://www.patemeadows.com). It is **not** the same thing as interfacing.
- We mounted our valance on hidden brackets constructed out of a 4" piece of 1 x 4 and angle irons. (See instructions on page 13.) We have also included directions for mounting this treatment on a wooden pole (page 15).

### MATERIALS

*These amounts are for a valance measuring 40" to 42" finished, installed width. See chart for other widths. These amounts are based on 54" wide fabric.*

#### Fabrics:

- 3 ¼ yards of decorative fabric for valance front\*\*
- 2 ½ yards drapery interlining to add body & shape\*
- 1 ½ yards of lining\*
- 2 ½ yards of contrasting fabric for lining of jabots and banding
- *Optional:* Trim along bottom edge – 4 yards

#### Supplies:

- Temporary fabric marker\*
- [Steam-A-Seam2® - ½" \\*](#)
- 1" bias tape maker \*
- 3 cover-your-own buttons 1 ½" diameter \*
- Glue gun
- Staple gun
- Three 4" pieces of a 1 x 4 board

\*Available at [www.patemeadows.com](http://www.patemeadows.com)

\*\*Allow extra fabric for matching of patterned fabric

### YARDAGE FOR OTHER WINDOW WIDTHS

Window Width	Face fabric*	Contrasting fabric for lining jabots & bands	Lining	Interlining	Optional Trim for bottom edge of valance
Up to 44"	3 ¼ yds	2 ½ yds	1 ½ yds	2 ½ yds	4 yds
44" to 67"	4 ½ yds	2 ½ yds	1 ½ yds	3 ¼ yds	5 yds
68 to 90"	5 ½ yds	3 yds	2 ¼ yds	4 yds	6 yds
90 to 113"	6 ½ yds	3 yds	3 yds	4 ¾ yds	7 yds

\* These amounts are based on 54" wide fabric. Allow extra fabric to match patterns and plaids. These amounts are based on unaltered swag sections (A). Allow extra fabric if swag section (A) has been enlarged (see page 3).