



PARTNER is the ultimate compact solution for discreet personal power and data, complimenting any office workstation or meeting room table.

PARTNER can be ordered with Australian or international power sockets, Data and AV connectivity, and our class leading TUF PD USB fast charger or TUF HP USB C fast laptop charger.

PARTNER is one of the smallest and most compact indesk solutions from OE Elsafe and is equipped with an easy open lid for a clean and contemporary look.

PARTNER is great for office desks, flip tables, hot desking, educational facilities or anywhere a compact solution is needed.



COMMON COMPONENTS



* Wide range of Data / AV cutouts and couplers available on request
QikFIT Modules available as standard in Black and White

PARTNER DIMENSIONS

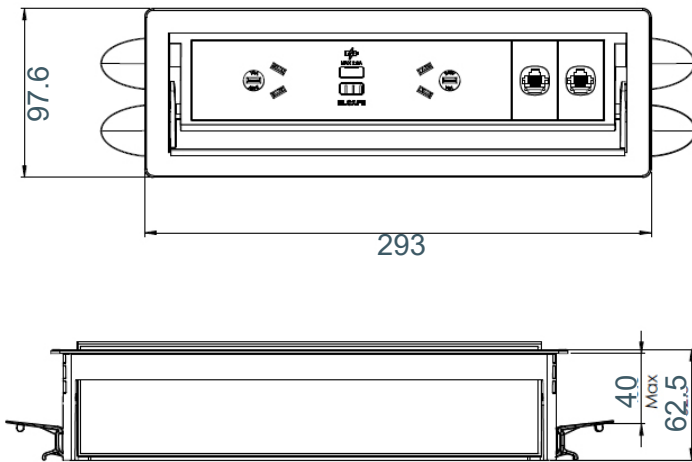

CUTOUT INSTRUCTIONS

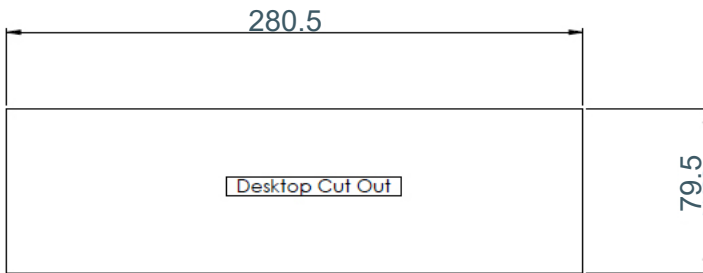

FEATURES

Power and Data configurations available

- Power or Data only
- Power and USB Fast Charging
- Combined (Power, USB Fast Charging & Data/AV)
- TUF-HP (high powered) USB Laptop Charging option
- International Sockets available on request

Reversible USB A Port: Accepts cable both ways.

Insulation: QikFIT modules with reinforced insulation.

Testing: 100% testing – continuity, polarity, insulation & earth.

Soft Wiring

Power hardwired to Wieland GST connector allows starter cables to be changed to suit requirements, especially useful during moves and changes (CHURN)

Soft Wiring (Data/AV)

As well as soft wired power, PARTNER can be supplied with pre-fabricated (100% end-of-line tested) fly leads for data (CAT5e, CAT6, CAT6A) and AV connections thereby providing a complete 'plug and play' soft wiring solution. If necessary, branded data can be accommodated to retain full channel warranties, please call for advice (see our Soft Wiring Data Brochure).

Partner is designed and intended for commercial use.

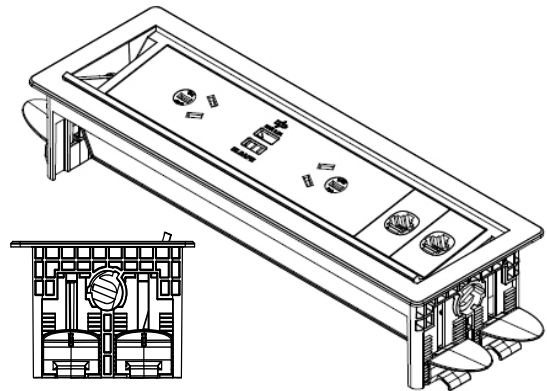

PARTNER
is perfect for
flip tables