





Find us on Social Media

-  @Loocam
-  @LoocamTech
-  @LoocamTech

Copyright 2021 © Loocam Technology LLC, California. All rights reserved.
Apple and App Store are trademarks of Apple Inc., registered in the U.S. and other countries.
Google and Google Play are trademarks of Google Inc.



Quick Start Guide

Wireless Security Camera System with 12.5 Inches
LCD Screen and 8-Channel NVR

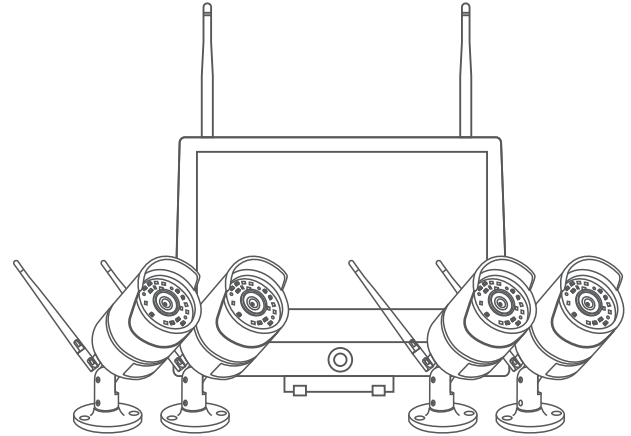

ATTENTION: Please read carefully and keep this guide in a safe place.
www.loocam.com

Contents

- 1. What's in the box 01
- 2. Product Overview 01
- 3. Installation and Setup 03
 - Security System Connection
 - Paring Add-on Camera
- 4. Operating NVR System 06
 - NVR System Setup
 - Video Recording
 - Motion Detection
 - Human Figure Detection
 - Backup via USB flash drive
 - System Upgrade via USB flash drive
- 5. Setup for Remote Viewing (Smartphone) 09
 - APP Download
 - Add Device
- 6. Setup for Remote Viewing (PC) 11
 - Client Installation
 - Add/Manage Device
 - Live view and Control
- 7. Camera Installation 12
 - Installation Tips
- 8. Warranty and Support 13

1. What's in the box

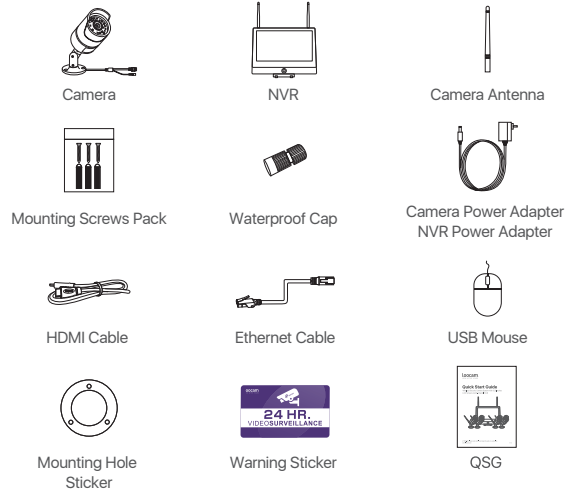

2. Product Overview

NVR

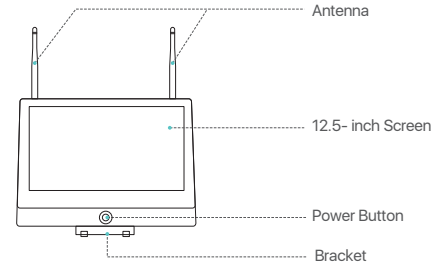

IP Camera

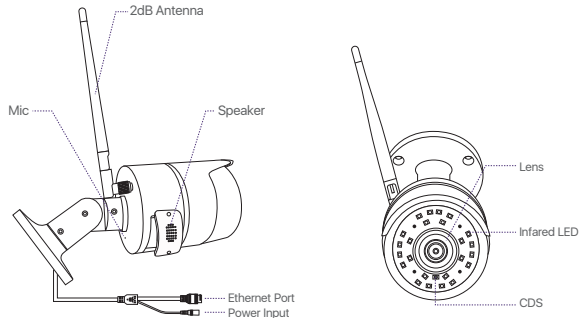

Safety Precautions

- Use the camera with compatible LOOCAM NVRs.
- Read this guide carefully and keep it for future reference.
- Follow all instructions for safe use of the product and handle with care.
- Use the camera within given temperature, humidity and voltage levels noted in the camera's specifications.
- Do not disassemble the camera.
- Do not point the camera directly towards the sun or intense light source .
- Use only a regulated power supply with the product . Using of a non-regulated, non-conforming power supply can damage the product and void the warranty.
- Periodic cleaning may be required. Use a damp cloth only. Do not use any harsh, chemical-based cleaners.

⚠ Do not open the case while power is on.

3. Installation and Setup

Some camera kits may not include hard drive, depending on the camera kit you purchase. This kit support most 3.5" HDD up to 8TB.

Note: Please skip this step if your recorder has a pre-installed hard disk.

- ① Power off the NVR, unscrew and remove the back cover of recorder.
- ② Align the holes of the hard disk with the holes of the back cover, and fix the hard disk on the back cover of NVR (As shown in figure 3.2).



Figure 3.1



Figure 3.2

- ③ Connect the power cable and data cable of the hard drive to the corresponding ports in the recorder, as shown in figure 3.3.

- ④ Close the back cover of the recorder and tighten the screws.



Figure 3.3



Figure 3.4

Note: After installing the hard disk, you should format the hard disk before recording. Right-click the mouse> enter the Main Menu> Hard Disk Management> select the hard disk> click Format> Apply

Security System Connection

To ensure that the product works properly and not damaged while in transit, we recommend you to test the whole system before installation.

- (1) Use a network cable to connect the NVR to the router.
- (2) Insert the USB mouse into the USB port on the side of the NVR
- (3) Connect the cameras to the power adapter (DC 12V/1A).
- (4) Connect the power adapter (DC 12V/2A) to the NVR power input.

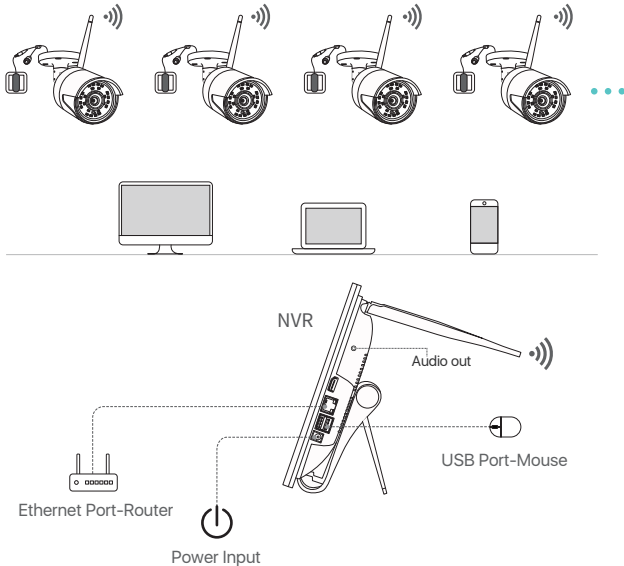

Pairing Add-on Camera

The cameras have been paired before shipping. Simply plug and play. It is recommended to test the system with the cameras before installation. If it does not work, try resetting the camera. If the problem still persists, please contact Loocam customer service.

To add a new camera or reset the camera, please follow the following steps. Take out the camera and install the antenna. Next connect NVR and camera with a network cable. Make sure the system can display normally on the monitor before performing the steps below.

- (1) Right-click on the mouse which is connected to the NVR for operation menu.
- (2) Click on the <IPC channel config> to enter the IPC channel configuration interface.

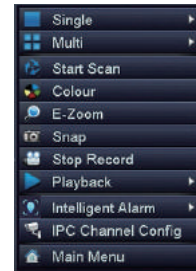

- (3) Click on the search button on the IPC channel configuration page to search for the corresponding IPC;
- (4) If you want to add the camera, select the IPC you wanted to add from the search result and click wireless add. Upon successful connection, the connected IPC will appear at the bottom of the page. Now you can see live feed from the newly added channel of the camera.

If you want to reset the camera, select the IPC to be reset from the search list, then click "Reset IPC", and wait for the camera to reset successfully. Repeat the above steps to reconnect the camera.

4. Operating NVR system

NVR System Setup

After connecting the system, power on the NVR and a Wizard page setting will appear. On the Wizard page setting, you can edit device name, select Language, Date Format, Time Format, Time Zone, System Date and System Time.



Password Setting:

From the NVR live viewing screen, right-click and tap Main Menu > Setup > Users. Select the account you want to set password and click <Change Password>. Default password (Empty). When setting the password, please enter at least 6 characters or more. Note: You can write down the password in case you forget.

Password: _____

Video Recording

From the NVR live viewing screen, right-click and tap Main Menu > Search, system will display as shown:

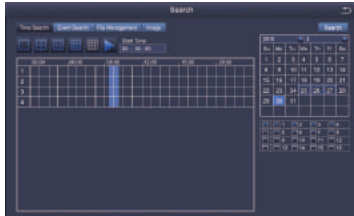

Search the video you want via Time or Event, then click on play button.



Select the channel



Start playing

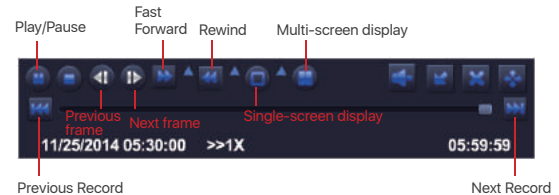

Previous Record:

Move to last recorded event

Next Record:

Move to next recorded event

Fast Forward:

Video can be played at different speed, from 1/4x to 16x speed.

Rewind:

Video play can be rewind at 1x, 8x, 16x and 32x speed.

Screen Display Mode:

Both single-screen and multi-screen are available. You can choose how many channels you want to playback one time. Channel without records displays blank screen.

Motion Detection

After setting motion detection, the NVR will only record when it detects movement or activity.

Right-click > Main Menu> Setup > Alarm > Motion.

Select the camera you want to setup motion detection by ticking the box under 'Enable'



Note: An icon  will be shown when motion is detected by the camera and the system will start recording.

Human Figure Detection

This NVR supports human figure detection. When human figure is detected, it will trigger alarm/recording. Combining motion detection and human figure detection, the false alarm rate will decrease.



Backup via USB flash drive

Insert the USB flash drive. Right click > Main Menu> Backup > select channel and time >

Search >select the video clips > Backup > select storage media > Start.

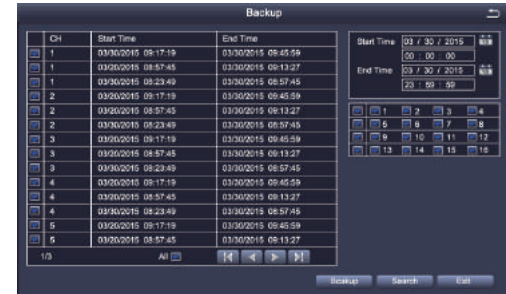

System Upgrade via USB flash drive

You can contact our official customer service or download the latest program directly from the official website. Copy the firmware file to the root of USB flash drive. Then proceed as follows:

First plug in the USB flash drive, and then unplug the NVR power supply. Plug in the power plug, you will see an "upgrading" upgrade interface on the monitor. Please wait for a while. After the upgrade is completed, unplug the USB flash drive and the upgrade has completed.

Note: After the upgrade is completed, please do not restart the power supply when the U disk is still plug in, otherwise the system will perform the upgrade again.

5. Setup for Remote Viewing (Smartphone)

APP Download

Scan the QR Code or search Loocam in AppStore or Google Play to download the free app.

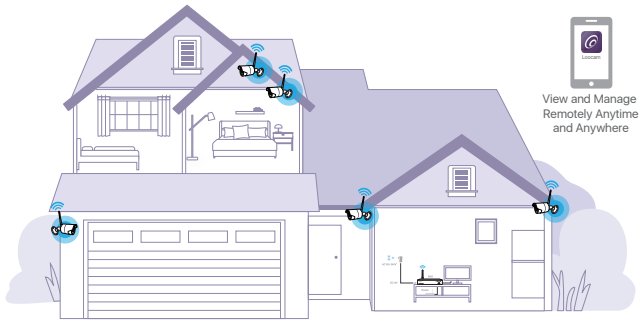

This camera system can work without internet connectivity. For the best user experience, remote-control via internet is recommended.

After downloading, register and create account.

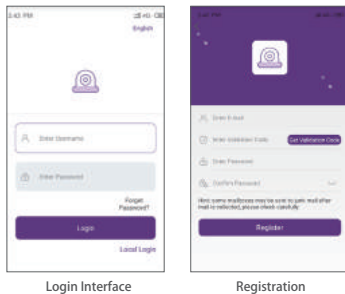

Note: You can write down your account information below, in case you forgot. (Registered email or phone number, user account name, password or a security question) _____

Add Device

- (1) Go to Loocam App in your phone, tap the icon [+] in the top right corner to add device.
- (2) Select your device type of NVR.
- (3) Scan the UID QR code on the NVR cover. This UID QR code also can be found on the NVR startup screen or in the NVR main menu (Information-System-Device ID).
- (4) Follow the instructions to add your device and watch the live streaming video.

Note: Two-way voice via Loocam App for cameras with built-in mic and speaker.

6. Setup for Remote Viewing (PC)

Client Installation

Download Mac or Windows client (AVSS) from Loocam official website www.loocam.com.

Note: If you have registered an account through Loocam APP, simply login using the same account for AVSS.

Add/Manage Device

Click  under Device List to add device, edit device or configure device.

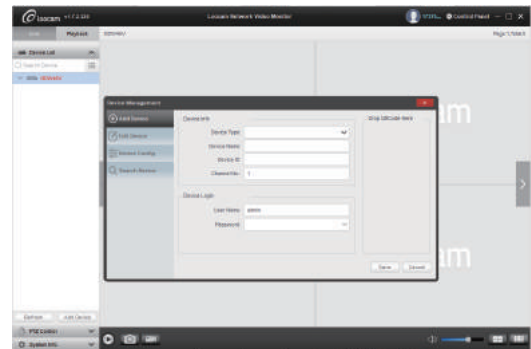

Live View and Control

Once you have successfully added device, click on the device name of the device you want to view under Device List, select the channels to start viewing.



- Play
- Screenshot
- Record
- Channel View
- Full Screen

7. Camera Installation

Step 1: Loosen the bracket screws, fold the camera bracket and screw the antenna in the corresponding place (as shown in the diagram).

Note: Install the cameras at least 7ft. above the ground with antenna vertical for optimal signal.

Step 2: Drill holes on the wall according to the position of the mounting hole sticker, and insert the plastic anchors into the holes.

Step 3: Align the mounting hole of the camera with the wall with the plastic anchors, then screw the screws in.

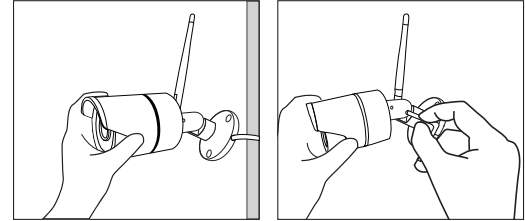
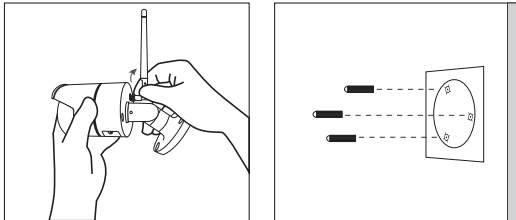

Installation Tips

- Refer to the image right for the ideal position. It is recommended to place the camera at least 7 ft. above the ground and tilting it towards the area of surveillance for best visual coverage.
- Ensure that the camera has clear line of sight.
- Place the camera at no more than 20 ft away from the area you want to monitor.

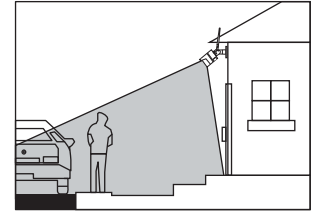

- Install the camera within the wireless signal range of the NVR.
- Install outdoor without worry. Cameras have strong weather resistance casing (IP66 full protection grade).
- Install the cameras within the maximum line-of-sight (LoS) distance of 2000ft. from the NVR. The maximum LoS distance will be reduced by each wall, ceiling or major obstruction between the cameras and the NVR.

8. Warranty and Support

Loccam Technology LLC provides a one-year limited warranty from the date of purchase. Please keep your dated purchase receipt which is required for limited warranty requests. For more details on warranty, please visit www.loccam.com.

If you have any questions in regards to your new Locom security product, please email us loccare@loccam.com.