

ITEM NO.	PRODUCT CODE	DESCRIPTION	QTY.
1	RWT2270T	2270L RAIN WATER TANK	1
2	OFF9	OVERFLOW PVC FLANGED 90MM	1
3	S3	300mm LEAF STRAINER	1
4	LH01	25mm [1"] BRASS BSP TANK OUTLET	1
5	BV1	25mm [1"] BALL VALVE - BRASS	1

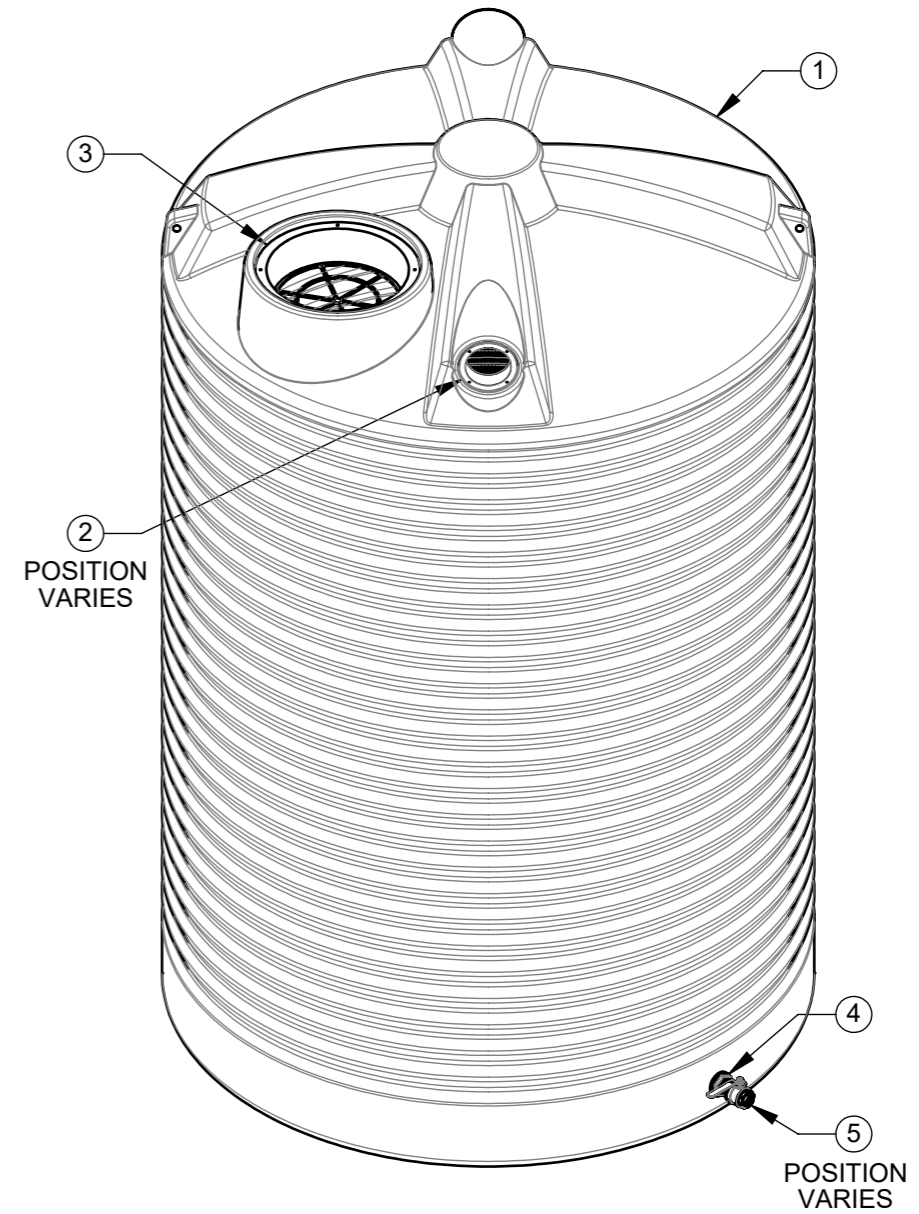

ISOMETRIC VIEW

NOTE:
DUE TO SHRINKAGE VARIATIONS IN MANUFACTURE,
ALL MEASUREMENTS ARE APPROXIMATE ONLY.

NOTE: ALL TOLERANCES UNLESS OTHERWISE STATED $\pm 10\text{mm} / \pm 1^\circ$
DO NOT SCALE, USE DIMENSIONS. ALL DIMENSIONS ARE IN mm
This drawing is the property of Polymaster Group Pty. Ltd. It cannot be copied
in part or in full without the written permission of Polymaster Group Pty. Ltd.

© POLYMASTER GROUP



161 KARINIE STREET
SWAN HILL. VIC.
3585
Ph: (03) 5033 9000
Fx: (03) 5033 0224

DESCRIPTION	2270L RAIN WATER TANK	A3 SHEET SIZE	SCALE: 1:15
PRODUCT CODE	RWT2270T		
MATERIAL			
COLOUR			
DRAWING No.	RWT2270T GA	DRAWN	MV 28/06/22 1/1 Rev: A