

MINI 112cm

MAXI 185.3cm

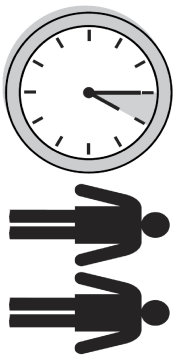
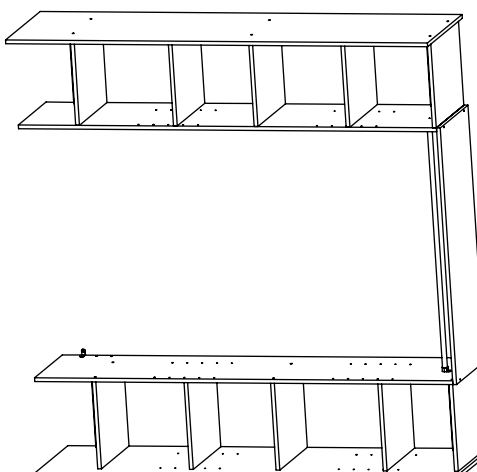
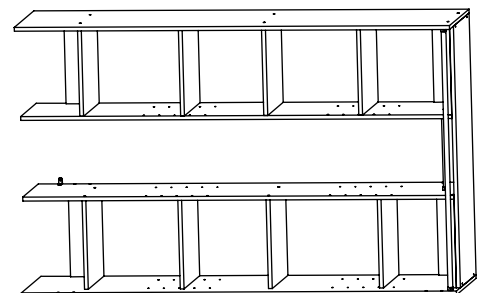

220512 Indice:D

4018

4021

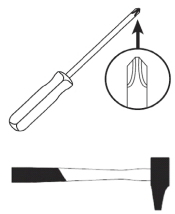

Contêntes z le contenu de votre colis avant de procéder au montage.
 - Ne défilez pas l'emballage. Il vous sera utile pour protéger les éléments des coups ou rayures pendant le montage.
 - Assemblez ensuite le meuble en suivant l'ordre défini par la numérotation.
 - Conservez ce notice et en cas de problème contactez notre service après vente.
 - Vormli de verpakking niet li ha het verwijderen van eventuele hulpjes kunt u het op de grond leggen om de plinten te beschermen tegen teessen en duwen tijdens het monteren.
 - Geleive de inhoud van uw pakket te controleren alvorens aan de montage te beeginnen.
 - Steek daarna het meubel in elkaar, de juiste volgorde van de nummering volgend.
 - Check the content of your parcel before assembling.
 - Do not throw away the packaging which could be very useful to protect the panels from the damage.
 - Assemble the article following the order of the numbers indicated.
 - Confira o conteúdo da sua encomenda antes de iniciar a montagem.
 - Proceda à montagem do móvel seguindo a ordem definida pela numeração, de golpes ou rasgos durante a montagem.
 - Para quando estiver a montar, conserve os nossos serviços através do telefone.
 - Para cualquier asesoramiento, contacte os nossos serviços através do telefone.

1	
CAX24	
ECX24	
DAX16	
DBX16	
ILX4	
RKX8	
NEDX4	
FBX4	
EAX16	
IX4	
NDX4	

Codé	Long	Larg	Ep	Qt
1	1816	500	16	2
2	1800	400	16	2
3	1087	400	16	1
4	368	398	16	10
6	368	120	16	4
8	1048			1
9	1816			1

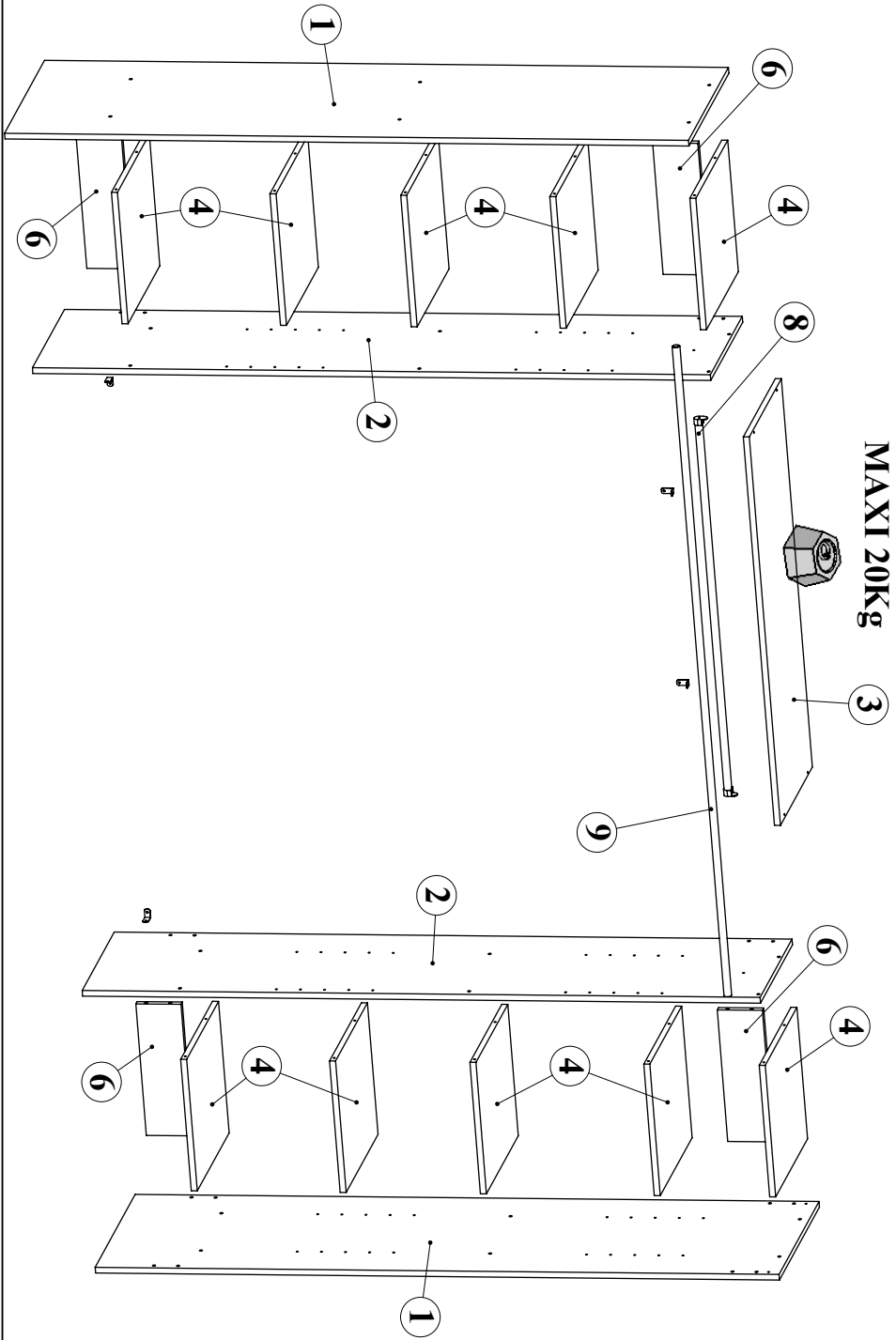

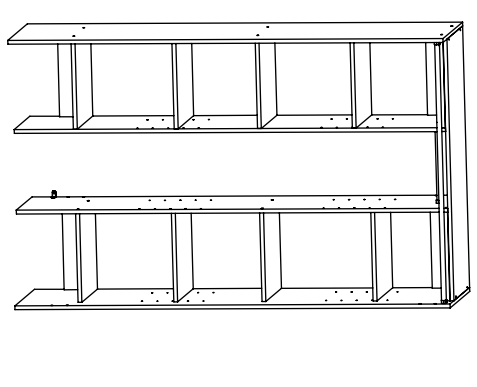
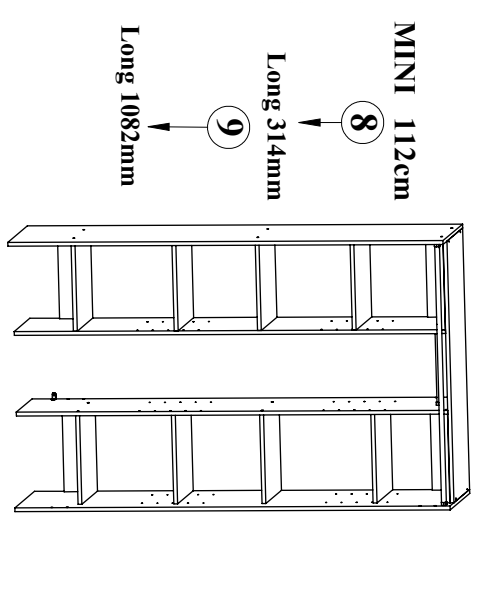
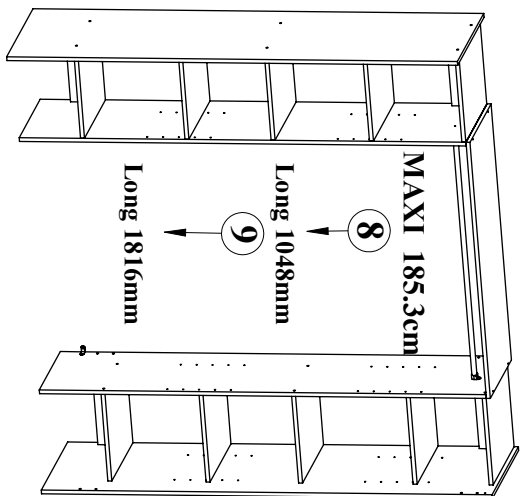
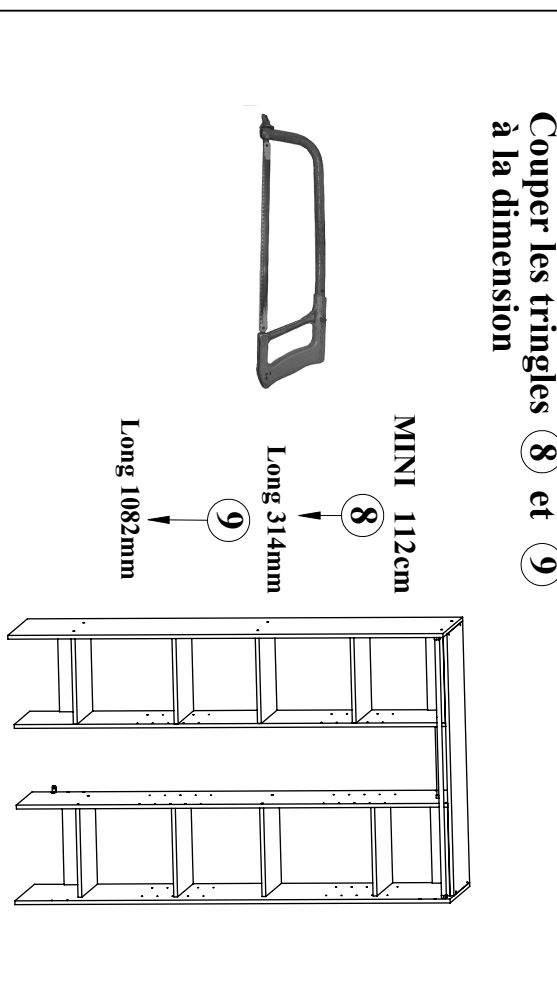
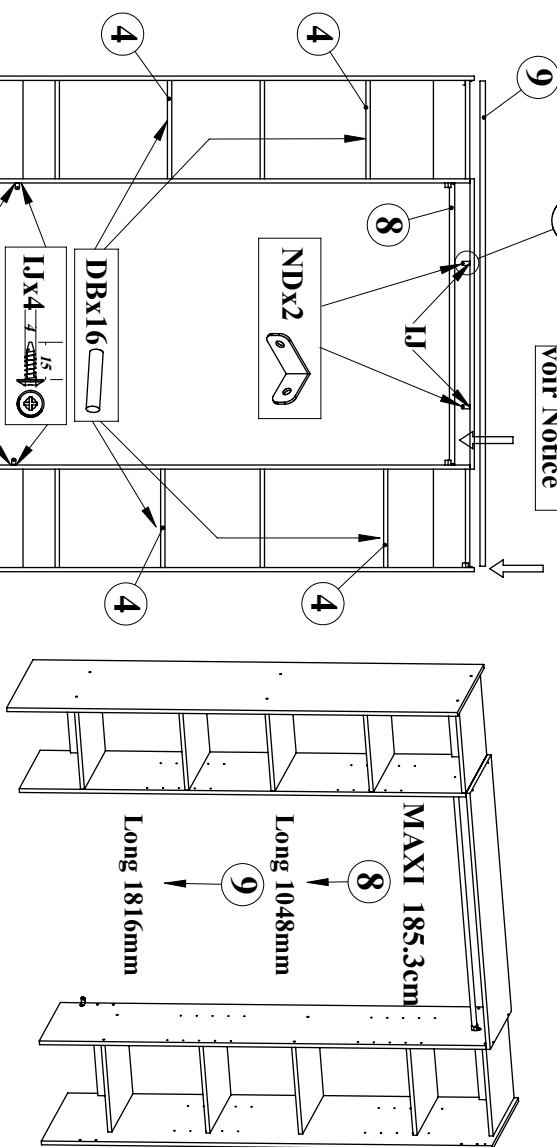
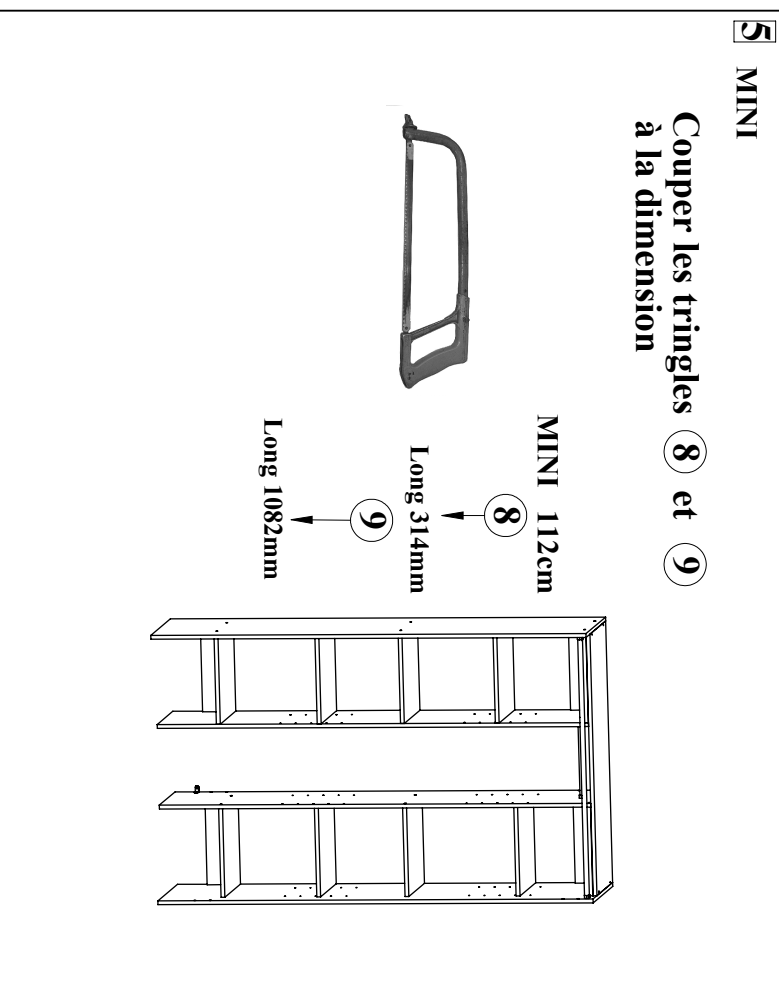
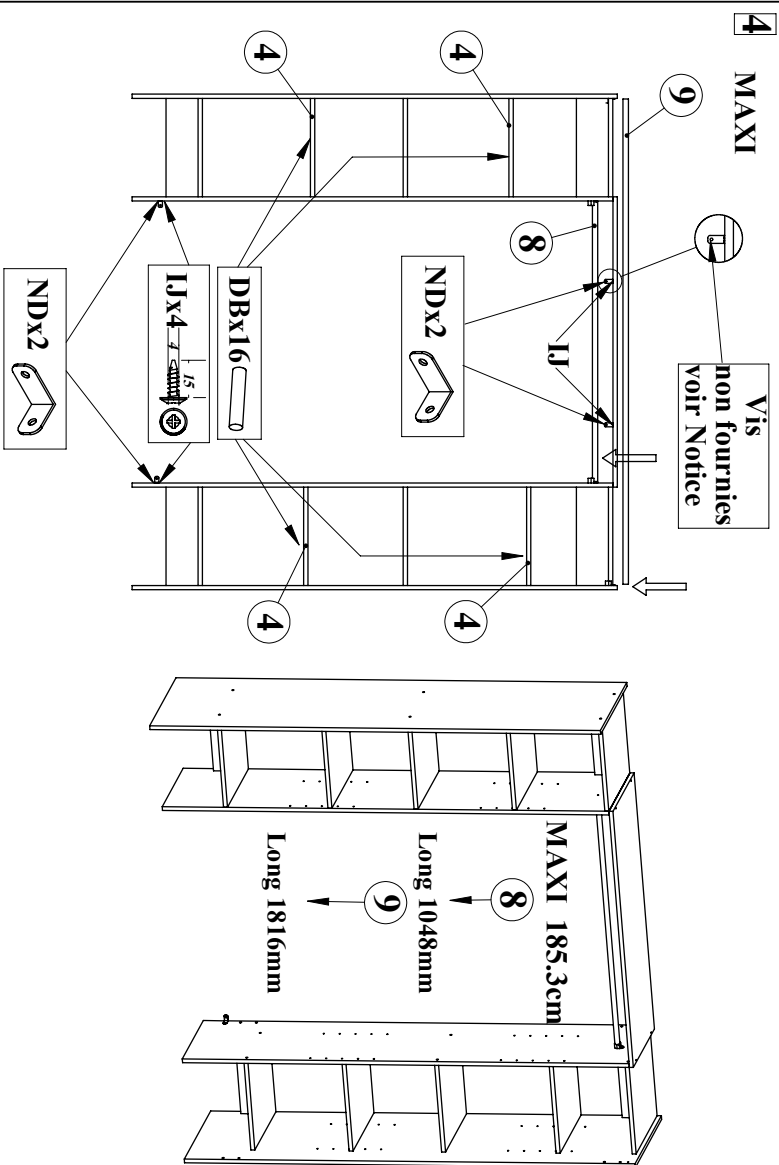
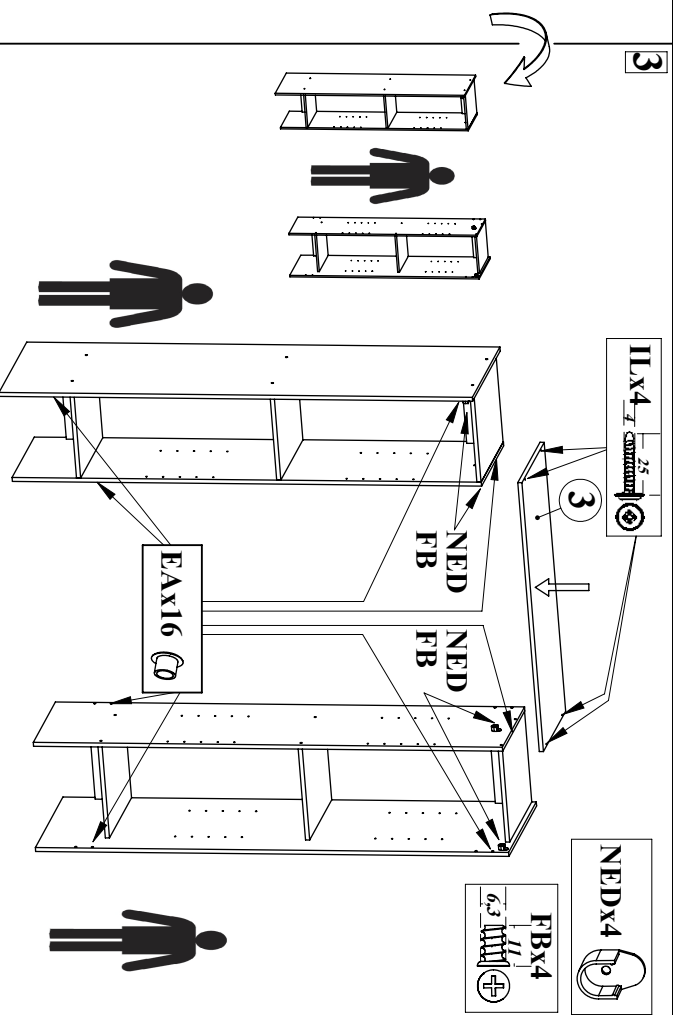
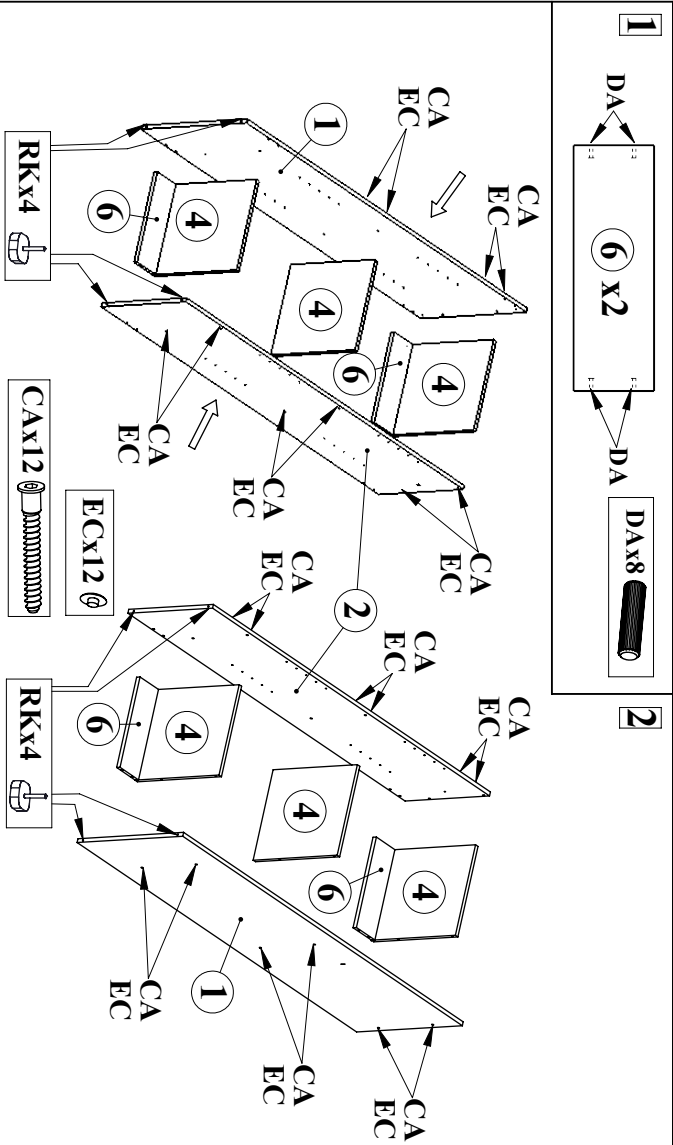

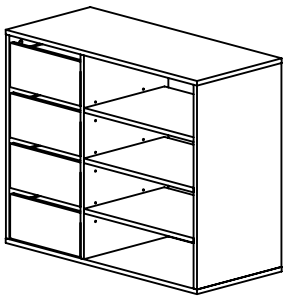

Notice de montage
Assembling instructions
Montageanleitung

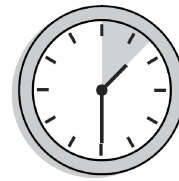

Symbiosis
easy living interiors

4085 IA (Prod. Ref)
Bloc de rangement
895 x 396 x 732

N° Pièce/Part/Teile

N° Pièce	Qte	Dimensions
1	1	895 x 396 x 16
2	1	895 x 396 x 16
3	1	700 x 395 x 16
4	1	700 x 395 x 16
5	1	700 x 395 x 16
6	3	513 x 376 x 16
7	1	342 x 704.50 x 3
8	4	329 x 152 x 16
9	4	360 x 120 x 12
10	4	360 x 120 x 12
11	4	299 x 120 x 12
12	4	354 x 308 x 3

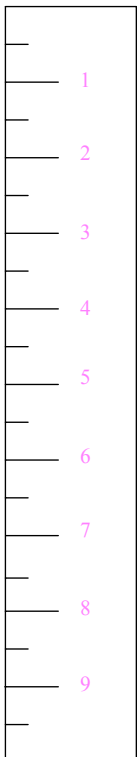
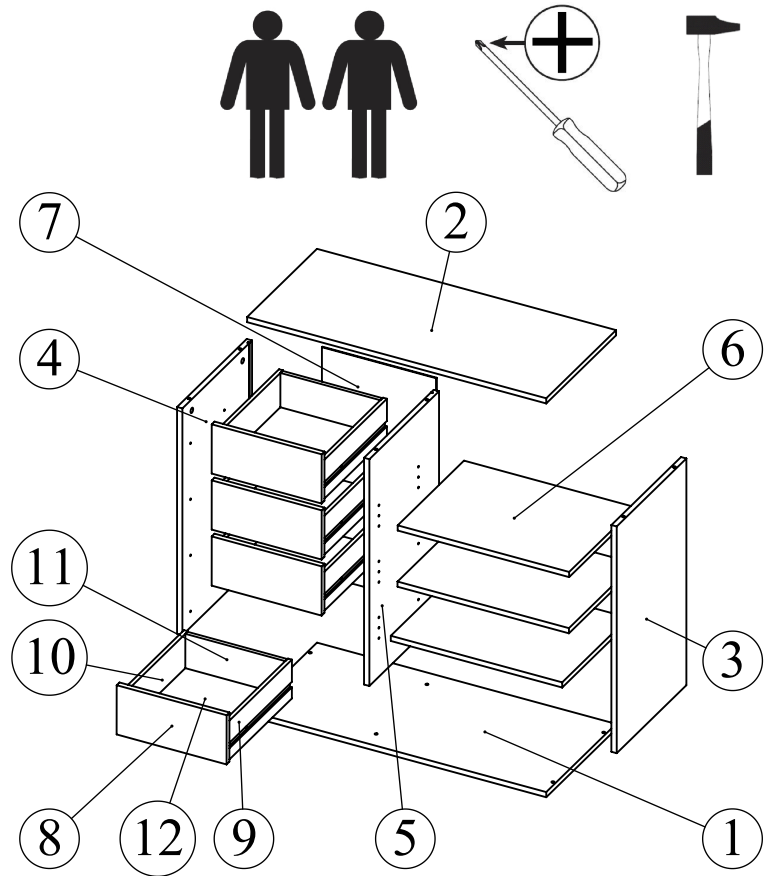

N° Pièce	Qte	Image
AA	6	
BA	6	
AB	8	
BB	8	
CA	6	
OH	8	
DD	12	
FB	16	
ITB	8	
ND	2	
IJ	2	
DA	24	
NM	2	
Clef	1	

1

BA  X6	AA  X6	FB  X16	DD  X12	OH  X8
----------------------------------------------------------------------------------------	----------------------------------------------------------------------------------------	-----------------------------------------------------------------------------------------	------------------------------------------------------------------------------------------	------------------------------------------------------------------------------------------

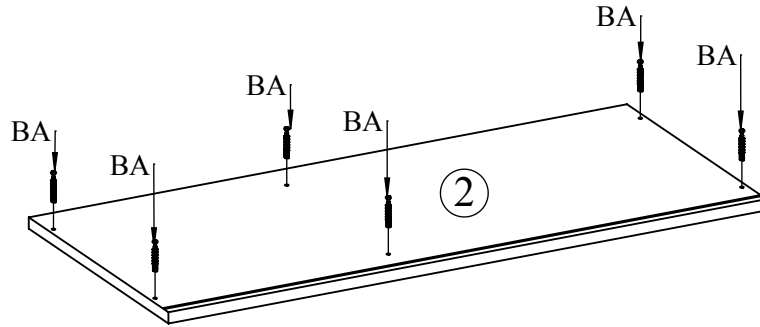
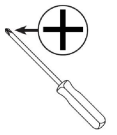

A

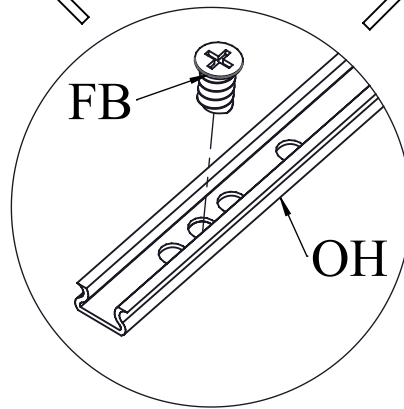
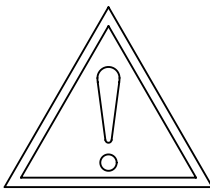
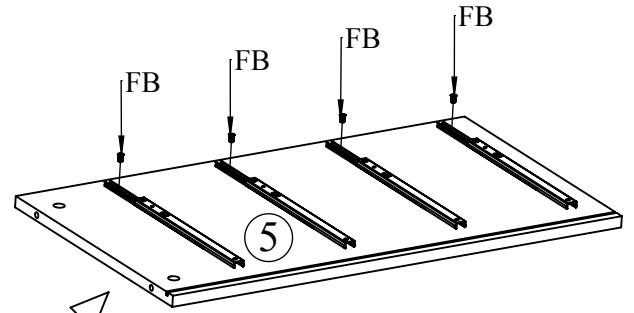
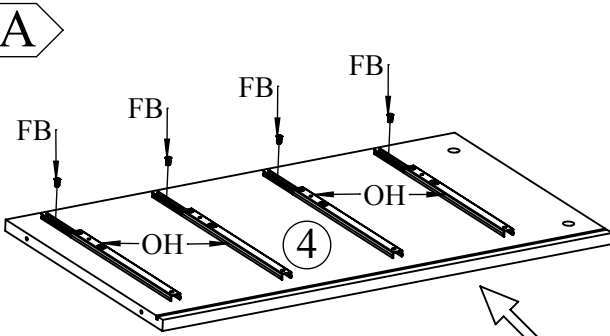

B

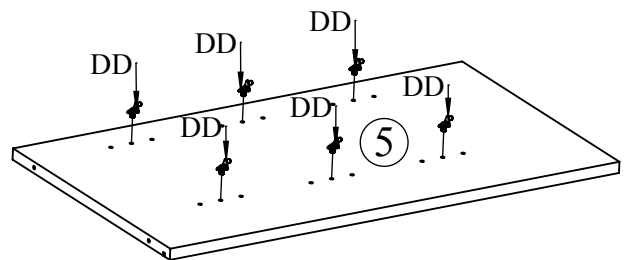
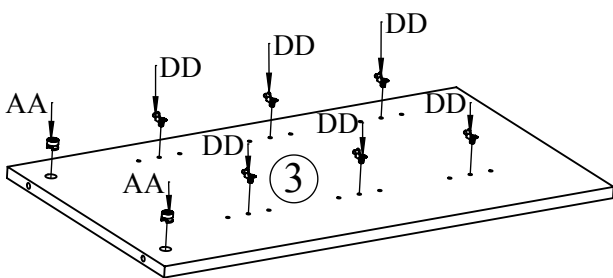
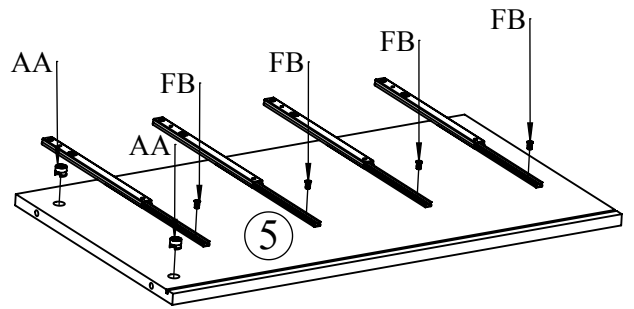
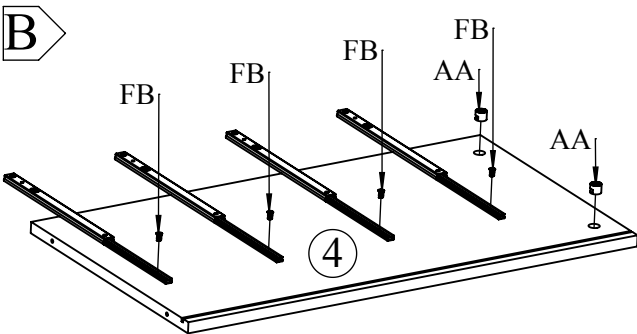

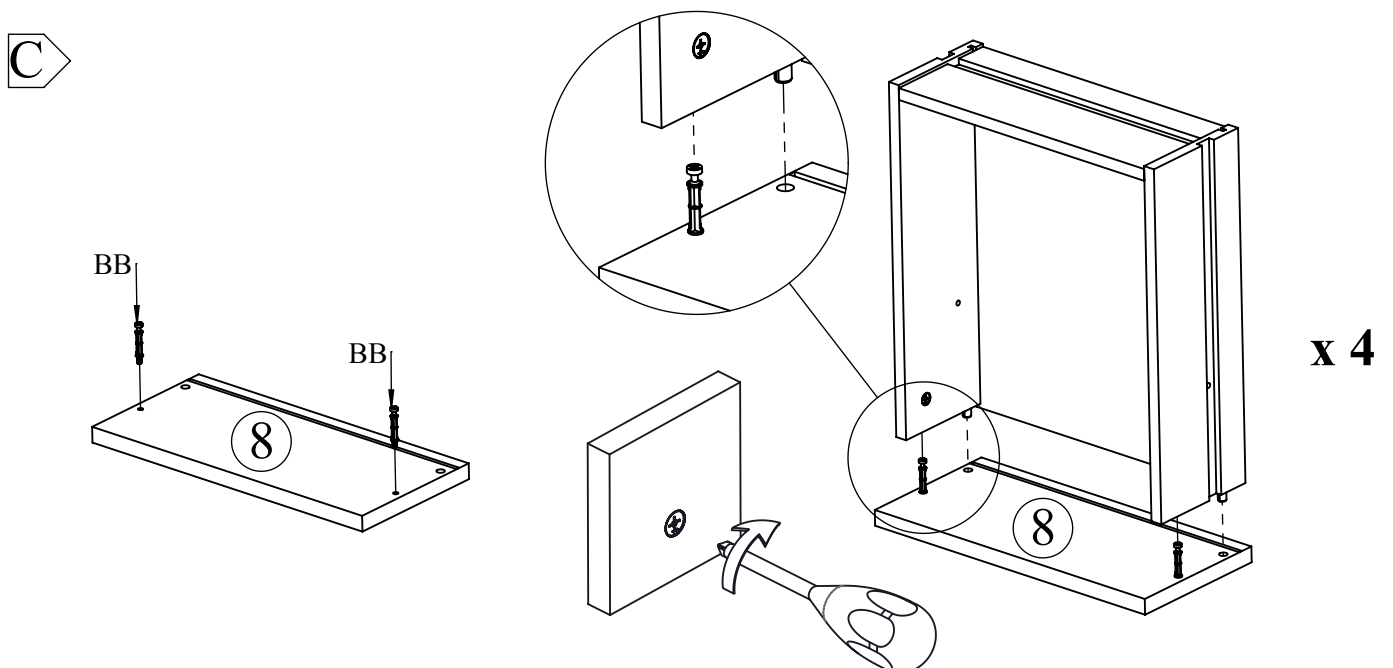
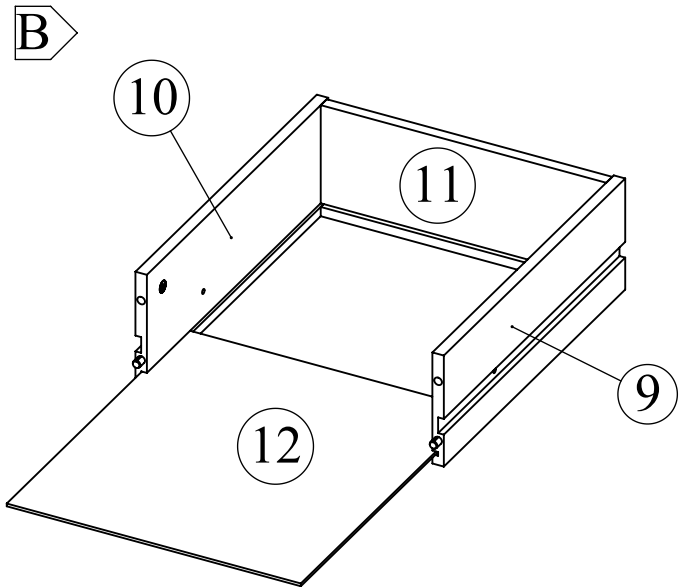
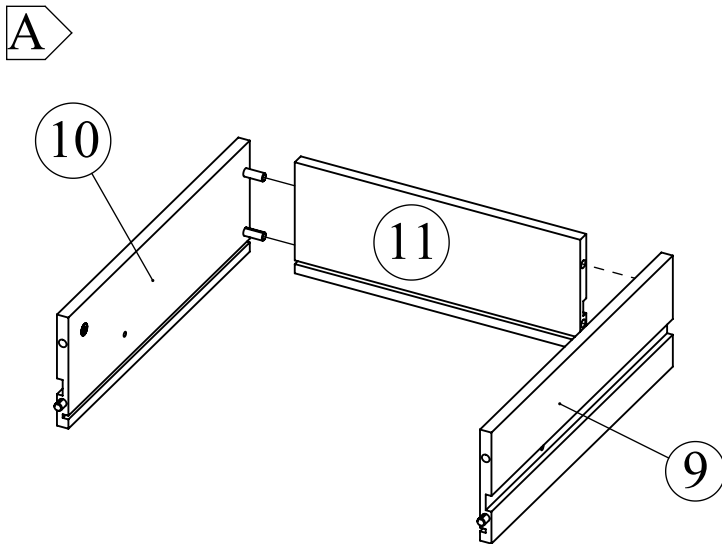
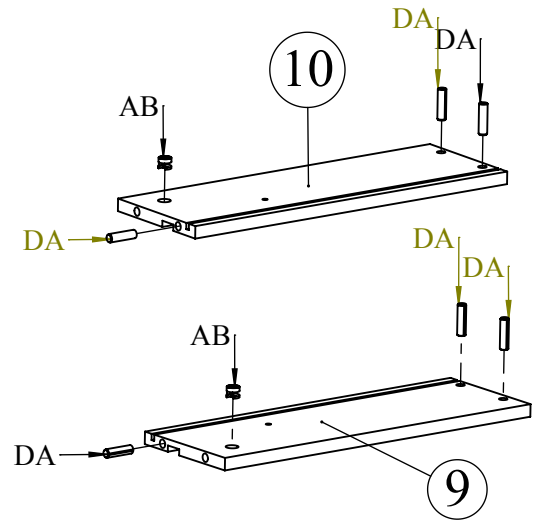
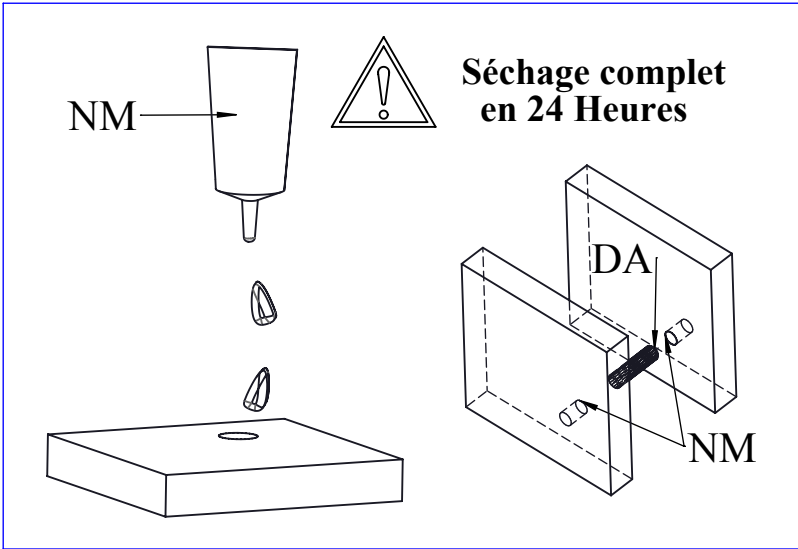
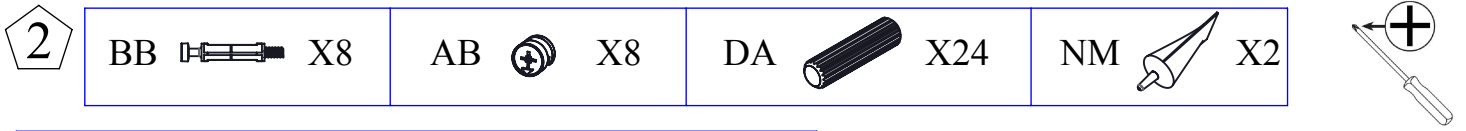

3

CA  x6

ITB  x8

IJ  x1

ND  x1

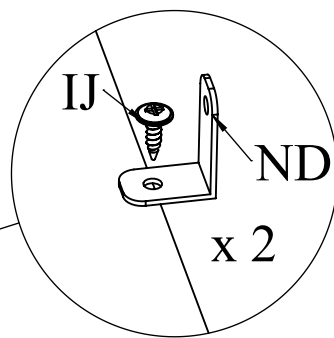
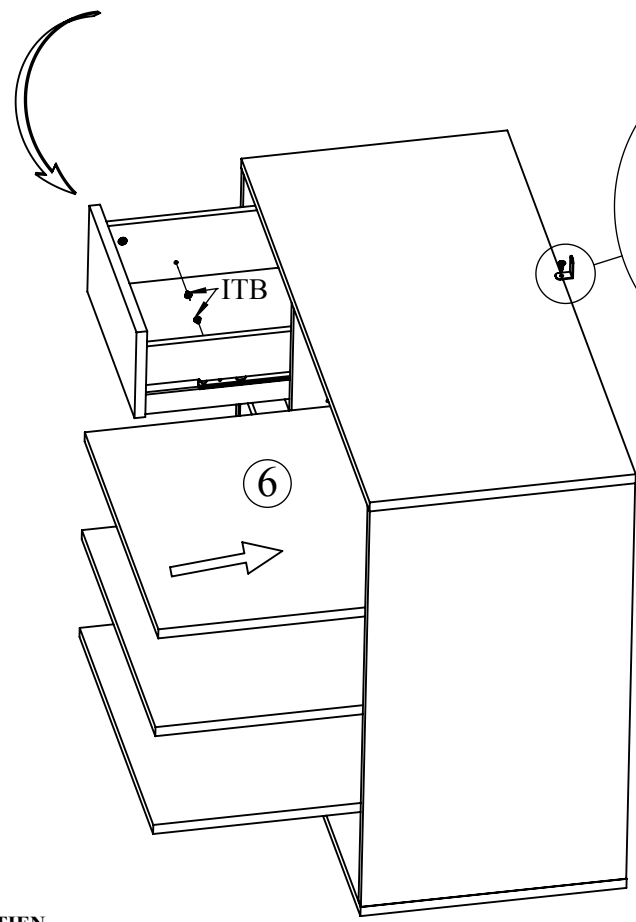
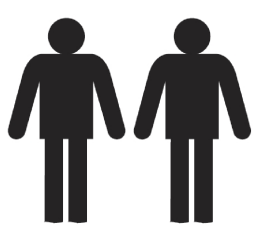
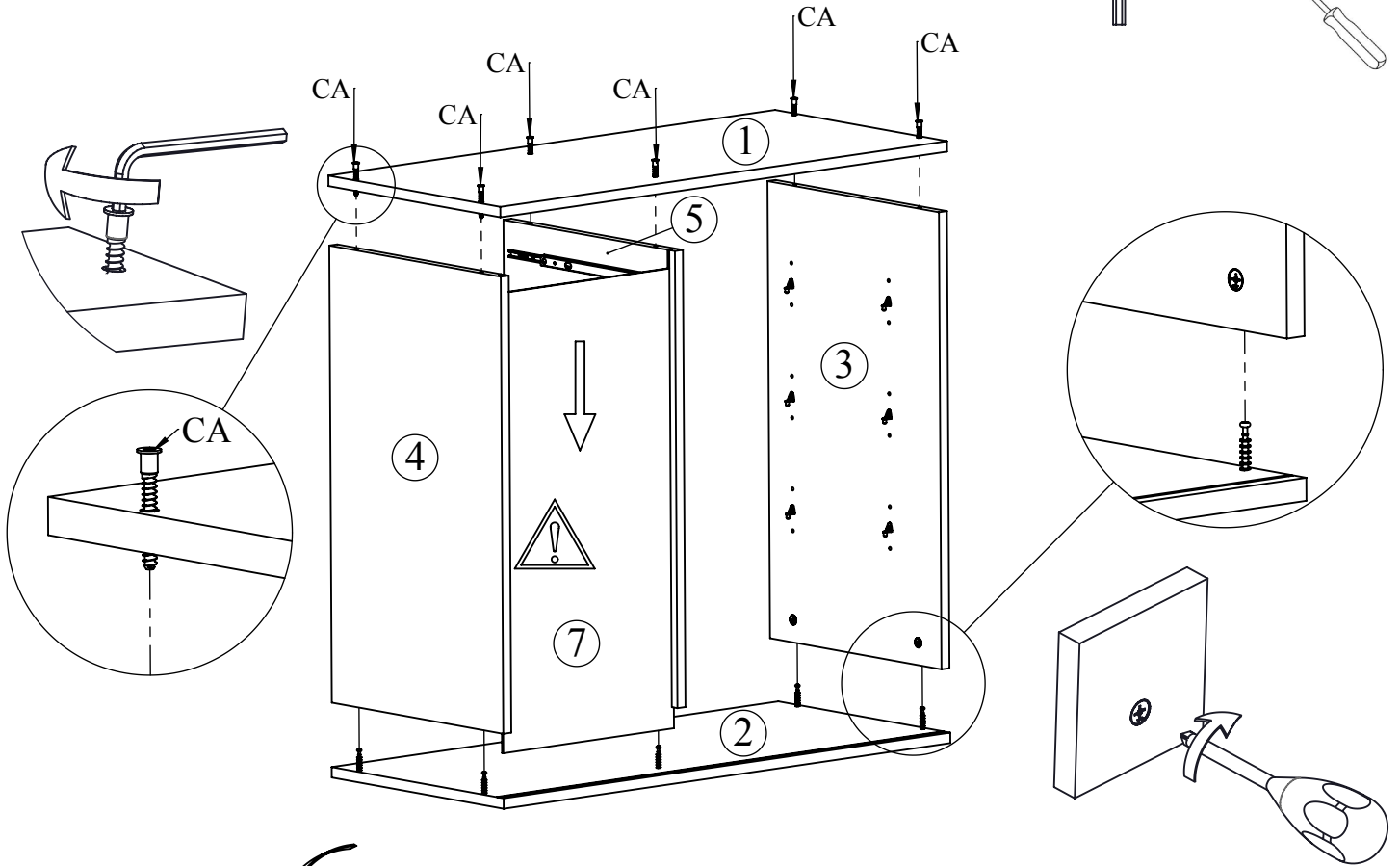
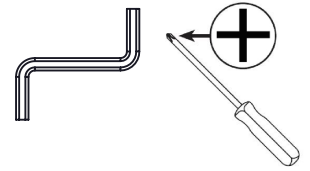

FR. Fixation murale impérative par une personne compétente avec vis et chevilles adaptées à la nature du mur.
EN. Unit must be secured to the wall by a competent person with appropriate screws and plugs
DE. Die Wandbefestigung muss von Fachmann und mit den dazu passenden Material montiert werden.

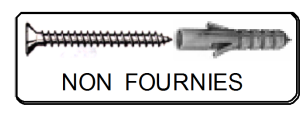

INSTRUCTIONS D'ENTRETIEN
 Laver les surfaces à l'aide d'un chiffon doux, préalablement trempé dans une solution savonneuse (max. 1%)
ATTENTION! Ne pas utiliser de produit contenant de l'alcool ou de l'abrasif.
 Essuyer à l'aide d'un chiffon doux.

CARE AND CLEANING INSTRUCTIONS
 Wash the surfaces with a soft cloth damped in a mild soap solution (max 1%).
NOTE! Do not use cleaners containing alcohol or abrasives.
 Wipe the surface dry with a soft cloth.

PFLEGEHINWEIS
 Zur Reinigung und Pflege verwenden sie, ein feuchter Lappen mit Seifenlauge (max 1%) zum Abwischen
WICHTIG! Keine alkoholhaltigen Mittel oder Schleifmittel verwenden.
 Die Oberfläche mit einem weichen Tuch abtrocknen.