

**KLIMAIRE**®

The Klimaire logo is a registered Trademark of Klimaire Products inc.  
Copyright 2010 Klimaire Products Inc.

2190 NW 89 Place, Doral, FL 33172 - USA  
Tel: (305)593-8358 Fax (305) 675-2212  
www.klimaire.com sales@klimaire.com

The design and specifications are subject to change without prior notice for product improvement. Consult with the sales agency or manufacturer for details.

**KSTIV**

**SERIES**

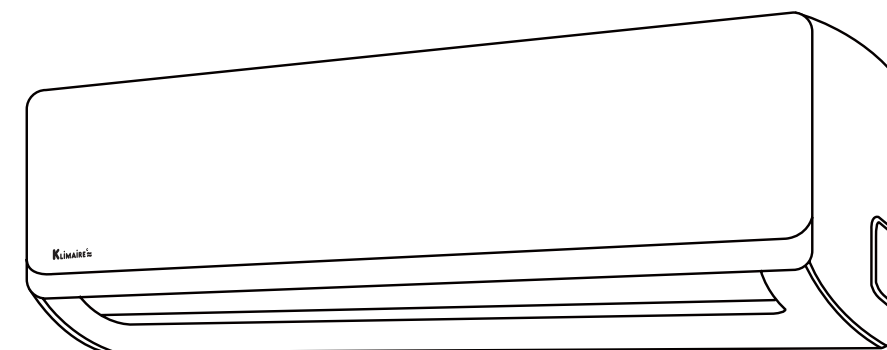

**KLIMAIRE**®

**SPLIT-TYPE ROOM AIR CONDITIONER**

# User's Manual

**IMPORTANT NOTE:**

Read this manual carefully before installing or operating your new air conditioning unit. Make sure to save this manual for future reference.



## **READ BEFORE OPERATION**

---

When using this air conditioner in the European countries, the following informations must be followed:

- This appliance can be used by children aged from 8 years and above and persons with reduced physical, sensory or mental capabilities, or lack of experience and knowledge if they have been given supervision or instruction concerning use of the appliance in a safe way and understand the hazards involved. Children shall not play with the appliance. Cleaning and user maintenance shall not be made by children without supervision.

**DISPOSAL:** Do not dispose of this product as unsorted municipal waste. Collection of such waste separately for special treatment is necessary.

It is prohibited to dispose of this appliance in domestic household waste. For disposal, there are several possibilities:

- A) The municipality has established collection systems, where electronic waste can be disposed of at least free of charge to the user.
- B) When buying a new product, the retailer will take back the old product at least free of charge.
- C) The manufacturer will take back the old appliance for disposal at least free of charge to the user.
- D) As old products contain valuable resources, they can be sold to scrap metal dealers.

Wild disposal of waste in forests and landscapes endangers your health when hazardous substances leak into the ground-water and find their way into the food chain.

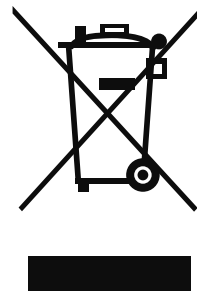

## **CONTENTS**

### **SAFETY PRECAUTIONS**

Warning .....	3
Caution .....	4

### **NAMES OF PARTS**

Indoor unit .....	5
outdoor unit .....	5
Display window .....	5

### **OPERATING INSTRUCTIONS**

Operating temperature.....	6
Manual operation .....	6
Airflow directional control .....	7
How the air conditioner works .....	8
Special functions .....	9

### **CARE AND MAINTENANCE**



Before maintenance.....	11
Cleaning the unit.....	11
Cleaning the air filter and air freshening filter .....	11
Preparation for extended non-operation.....	12
Pre-season inspection.....	12

### **TROUBLESHOOTING TIPS**



Troubleshooting tips.....	13
Troubleshooting guide .....	14

## SAFETY PRECAUTIONS

To prevent injury to the user or other people and property damage, the following instructions must be followed. Incorrect operation due to ignoring of instructions may cause harm or damage. The seriousness is classified by the following indications.

 <b>WARNING</b>	This symbol indicates the possibility of death or serious injury.
 <b>CAUTION</b>	This symbol indicates the possibility of injury or damage to property.

■ Meanings of symbols used in this manual are as shown below.

	<b>Strictly prohibited.</b>
	<b>Be sure to follow the instructions.</b>

### **WARNING**



- Do not extend the cable and never use multiple plugs. A poor electrical connection, poor insulation or voltage which is higher than permitted can cause fire.
- Do not expose your body directly to the cool air for prolonged period.
- Never poke fingers, sticks or other objects in the air inlet and outlet vents.
- Never attempt to repair, relocate, modify the air conditioner yourself. Always contact your service provider if required.
- Never pull the plug out by pulling on the cable. Hold the plug firmly and pull it out of the plug socket, otherwise there is a risk of damaging the cable.
- Do not operate your air conditioner in a wet room such as a bathroom or laundry room.



- Remove all dirt from the power plug and plug it firmly. Soiled plugs can cause fire or an electric shock.
- In the event of any abnormalities such as smell of burning, immediately switch off the device and pull the plug. Contact your service provider.
- Always switch off the device and pull the plug before you start to clean it.
- Use specified power cord.
- Contact the authorized installer for installation of this unit.
- Contact an authorized service technician for repair or maintenance of this unit.
- This appliance is not intended for use by persons (including children) with reduced physical, sensory or mental capabilities, or lack of experience and knowledge, unless they have been given supervision or instruction concerning use of the appliance by a person responsible for their safety.
- Children should be supervised to ensure that they do not play with the air conditioner.

## SAFETY PRECAUTIONS

### **CAUTION**



- Never actuate any switches with a wet hand. It may cause an electric shock.
- Never use the device for any other purpose than the intended use. Never place food, precision instruments, plants, animals, paint, etc. on the unit.
- Do not expose plants or animals directly to the air flow.
- Never clean the air conditioner with water.
- Never use combustible cleaning agents as these could cause a fire or deformation.
- Never place any burning objects close to the device if they could be directly affected by the emitted air.
- Never step onto the outdoor unit and never place anything on it.
- Never use an unsteady or rusty base.
- Never install the air conditioner in places where combustible gas can be emitted.
- Emitted gas may collect and cause an explosion.
- Never allow the air conditioner to run for too long with the doors or windows open, or if the humidity is very high.



- If the air conditioner is to be used in conjunction with other heaters, the air should be refreshed periodically, otherwise there is a risk of lack of oxygen.
- Always pull out the power plug if the unit is not going to be used for any lengthy period of time. Collections of dust can cause fire.
- Always switch off the air conditioner and pull out the power plug during a storm, otherwise, electrical parts may get damaged.
- Check that the drainage line is correctly connected. If not, water will escape.
- Check that the condensation water can run off unhindered. It may cause water damage if the condensation water cannot run off properly.
- The air conditioner must be earthed in accordance with the local codes.
- For electrical safety purposes we recommend that you install an earth-leakage circuit-breaker.
- If the power cord is damaged, it must be replaced by the manufacturer, its service agent or similarly qualified persons in order to avoid a hazard.

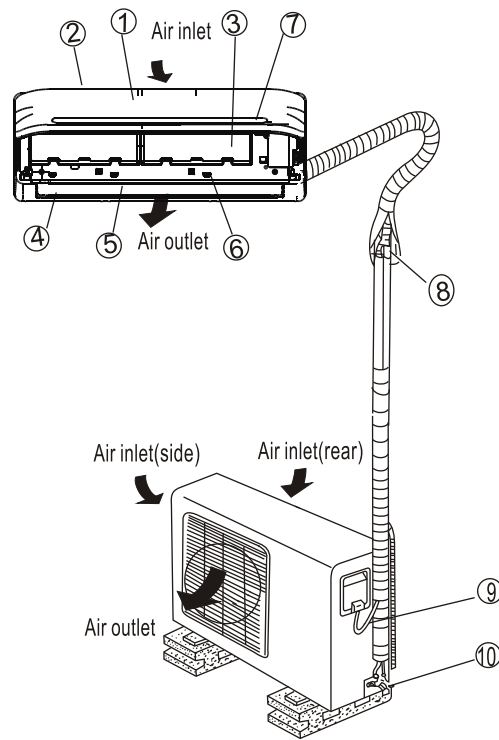

**Names of parts**

**Indoor unit**

1. Front panel
2. Air inlet
3. Air filter
4. Air outlet
5. Horizontal air flow grille
6. Vertical air flow louver(inside)
7. Display window

**Outdoor unit**

8. Connecting pipe
9. Connecting cable
10. Stop valve

**NOTE:**

All the pictures in this manual are for explanation purposes only. The actual shape of the indoor unit you purchased may be slightly different on front panel and display window. The actual shape shall prevail.

**Display window**

**Display window**

The display window of indoor unit may look like one of the following:

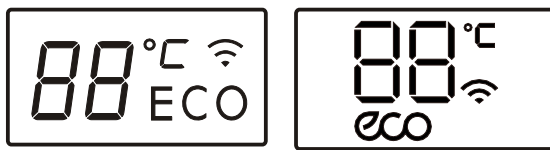

**ECO**

**Energy saving display(optional):**

Displays when the energy saving feature is activated.



**Wireless control display(optional):**

Displays when the Wireless control feature is activated.

**NOTE:**

A guide on using the infrared remote is not included in this literature package.

**BB Digital display:**

- Displays the temperature settings when the air conditioner is operational.
- Displays the room temperature in FAN mode.
- Displays the self-diagnostic codes.
- Displays 'ON' for three seconds when Timer ON, Fresh, Swing, Turbo or Silence feature is activated.
- Displays 'OF' for three seconds when Timer OFF is set.
- Displays 'OF' for three seconds when Fresh, Swing, Turbo or Silence feature is cancelled.
- Displays 'DF' under defrosting operation.
- Displays 'EF' when anti-cold air feature is activated under heating mode.
- Displays 'SC' during self clean operation(if applicable).
- Displays 'FF' under 8°C heating operation(if applicable).

**°C (Optional)**

- According to the operation mode, the "°C" indicator displays different colour:
- Under Cool or Dry mode, it displays as cool colour.
  - Under Heat mode, it displays as warm colour.

**Operating temperature**

Mode	Cooling operation	Heating operation	Drying operation
Room temperature	17°C~32°C (62°F~90°F)	0°C~30°C (32°F~86°F)	10°C~32°C (50°F~90°F)
Outdoor temperature	0°C~50°C (32°F~122°F)	-15°C~30°C (5°F~86°F)	0°C~50°C (32°F~122°F)
	-15°C~50°C/5°F~122°F) ( For the models with low temperature cooling system		0°C~60°C/32°F~140°F) (For special tropical models)
	0°C~60°C/32°F~140°F) (For special tropical models)		0°C~60°C/32°F~140°F) (For special tropical models)

**NOTE:**

1. Optimum performance will be achieved within these operating temperatures. If air conditioner is used outside of the above conditions, certain safety protection features might come into operation and cause the unit to function abnormally.
2. Room relative humidity less than 80%. If the air conditioner operates in excess of this figure, the surface of the air conditioner may attract condensation. Please sets the vertical air flow louver to its maximum angle (vertically to the floor), and set HIGH fan mode.

**Suggestion:** For the unit adopts an Electric Heater, when the outside ambient temperature is below 0°C(32°F), we strongly recommend you to keep the machine plugged in order to guarantee it running smoothly.

**Manual operation**

Units are equipped with a switch to run emergency operation mode. It can be accessed by opening the front panel. This switch is used for manual operation in case the remote controller fails to work or maintenance necessary.

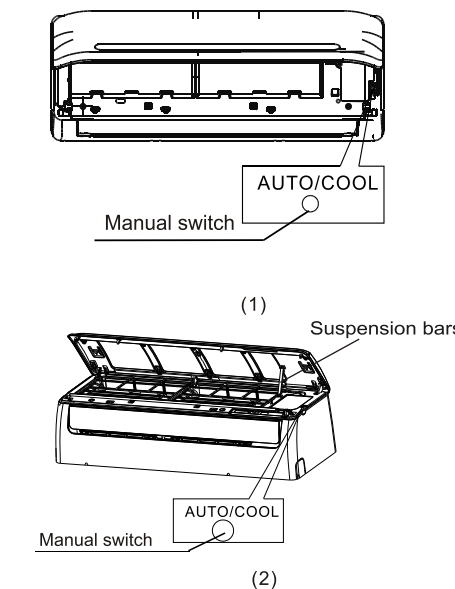

- ① Open the front panel by carefully lifting both ends at the same time. Once lifted sufficiently, a click is heard and it becomes self-supporting. For some models, please use suspension bars to prop up the panel.
- ② One press of the manual control switch will lead to the forced AUTO operation. If press the switch twice within five seconds, the unit will operate under forced COOL operation.
- ③ After operation, close the panel by firmly tugging downwards on both ends until it returns to its original position.

**CAUTION:**

- This switch is used for testing purposes only. Please do not use it unless necessary.
- To restore the remote controller operation, use the remote controller directly.



**Airflow directional control**

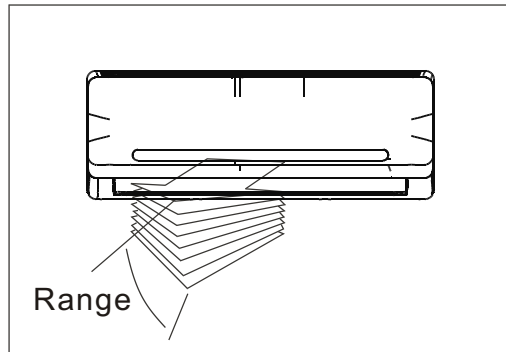

- Adjust the air flow direction properly, otherwise it might cause discomfort or cause uneven room temperatures.
- Adjust the horizontal louver using the remote controller.
- Adjust the vertical louver manually.

**Adjusting vertical air flow(Up--Down)**

Perform this function while the unit is in operation. Use the remote controller to adjust the vertical air flow direction. The horizontal louver can move slightly for each press, or continuously swing up and down automatically. Please refer to the ‘‘REMOTE CONTROLLER OPERATION MANUAL’’ for details.

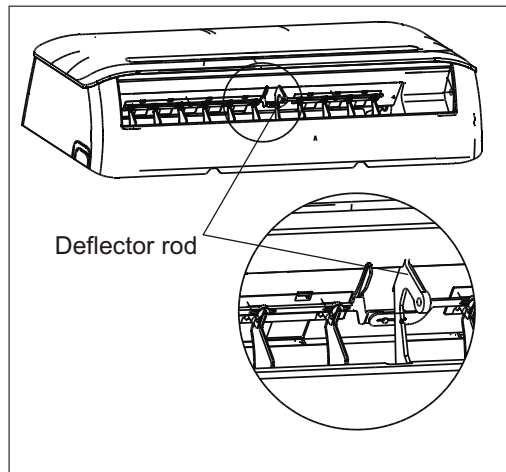

**Adjusting horizontal air flow (left - right)**

- Move the deflector rod manually to adjust the air flow in the direction you prefer.
- IMPORTANT:** Do not put your fingers into the panel of the blower and suction side. The high-speed fan inside may cause injury.
- For some models, the vertical louver can be adjusted by using the remote controller. Please refer to the ‘‘REMOTE CONTROLLER OPERATION MANUAL’’ for details.

**CAUTION**

- Do not operate the air conditioner for long periods with the air flow direction set downward in cooling or dehumidifying mode. Otherwise, condensation may occur on the surface of the horizontal louver causing moisture to drop on to the floor or on furnishings.
- After a quick restart, the horizontal louver may remain static for approximately 10 seconds.
- Open angle of the horizontal louver should not be set too small, as COOLING or HEATING performance may be reduced due to too restricted air flow area.
- Do not move the horizontal louver manually, otherwise the horizontal louver will be out of sync. But if this happens, please cease operating, unplug power for a few seconds, then restart the air conditioner.

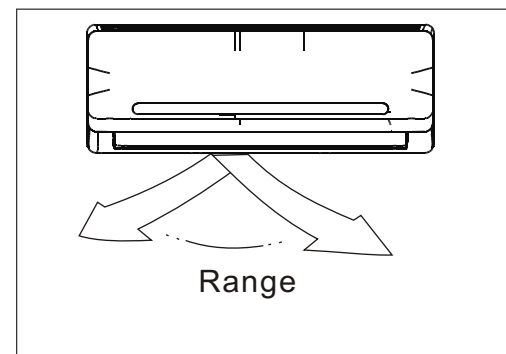

**How the air conditioner works**

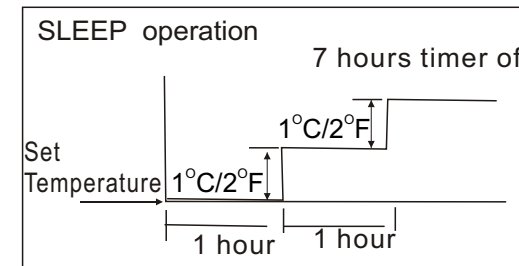

**Cooling**

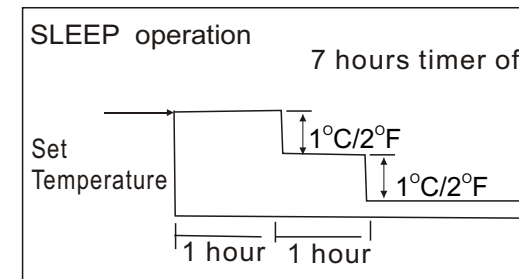

**Heating**

**Basic operation modes:** AUTO/COOL/DRY/HEAT \*  
 (\* ) Model dependent

**AUTO operation**

- When you set the air conditioner in AUTO mode, it will automatically select cooling, heating(cooling/heating models only), or fan only operation depending on set temperature and the room temperature.
- The air conditioner will control room temperature automatically to the temperature point you set.
- If you feel uncomfortable in the AUTO mode, you can set your desired temperature.

**SLEEP operation**

When selected, the set temperature will increase (cooling) or decrease (heating) by 1°C/2°F per hour for the first 2 hours. Thereafter it keeps this new temperature for 5 hours before switching off. This operation saves energy and improves night time comfort by synchronising with the body’s metabolism.

**DRYING operation**

- The temperature is regulated while dehumidifying by repeating turning on and off of the cooling operation or fan only. The fan speed is LOW.

**HEATING operation**

This air conditioner operates on the heat-pump principle, absorbing heat from air outdoors and transferring that heat to the indoor unit. As a result, the operating performance is reduced as outdoor air temperature drops. If you feel that the heating performance is insufficient, we recommend you to use this air conditioner in conjunction with other kinds of heating appliance.

**Optimal operation**

To achieve optimal performance, please note the following:

- Adjust the air flow direction correctly so that it is not towards people.
- Adjust the temperature to achieve moderate comfort levels. Excessively low or high temperature waste energy.
- Improve performance by keeping windows and doors closed.
- Limit energy usage(run time) by using the TIMER function.
- Do not put any object near air inlet or air outlet, as the efficiency of the air conditioner may be reduced and may cause the air conditioner to stop running.
- Inspect the air filters periodically, and clean them when needed.

**Special functions****Refrigerant Leakage Detection(Optional)**

When refrigerant leakage is detected, the indoor unit will display 'EC' code or flash LEDs(model dependent).

**Louver Angle Memory Function(optional):**

Within the scope of safety angle, the horizontal louver angle is memorised and will return to the position last selected by user. If it exceeds, it will memorize the boundary of safety angle. This will not happen when Turbo or manual control buttons are pressed or after a power interruption. So we strongly suggest that the open angle of the horizontal louver should not be set too small, in case the condensed water forms and drips from the horizontal louver.

**SELF CLEAN function(Optional)**

- Airborne bacteria use the moisture on the indoor heat exchanger to grow. Regular drying of the exchanger prevents this growth. By simply pressing the SELF CLEAN button, the system will automatically manage the process. This cleaning action may be done as frequently as desired.
- For cooling models, only the indoor fan is active in low speed for 30 minutes and the unit turns off automatically.
- For cooling & heating models, the unit will operate as in the following sequence : FAN mode at Low fan speed--Heating operation with LOW fan speed ---FAN operation--Stop Operation---Turn off.

**Note:**

- This function is only activated in COOLING or DRY mode.
- Before activation the air conditioner, it is recommended to run the air conditioner under cooling operation for about 30 minutes.
- Pressing the SELF CLEAN or ON/OFF button again during the cleaning cycle will cancel the operation and turn the unit off.

**CLEAN AIR function(Optional)**

Improving the quality of indoor air is one of the purposes of an air conditioner. This air conditioner is equipped with ionizer or Plasma Dust Collector(model dependent). With the anions generated by Ionizer, the air circulation of the air conditioner fills the room with refreshing, natural and healthy air. The Plasma Dust Collector generates a high voltage ionization zone, through which the air is converted to plasma. Inside the air most of the dust, smoke, and pollen particles are captured by the electrostatic filter.

**Anti-mildew function(Optional)**

When turns off the unit on COOL, DRY, AUTO (Cool) mode, the air conditioner will continue operating for about 10 minutes (depending on models) with soft wind. This will help to dry up the condensed water inside the evaporator, and prevent the mildew growth. Under Anti-mildew operation, do not restart the air conditioner until the unit is completely off.

**Auto-restart function(Optional)**

In event of power interruption such as a blackout, the air conditioner stops once. But it restarts automatically and performs previous operation when the power supply is resumed.

**Wireless Control Function(optional)**

Wireless control allows you to control your air conditioner using your mobile phone and a wireless connection. For the USB device access, replacement, maintenance operations must be carried out by professional staff.

**Air Filter Reminding Function(optional)****Cleaning filter reminding function:**

After 240 hours of operation, the indoor display window will display and flash 'CL', this feature is a reminder to clean the Air Filter for more efficient operation. After 15 seconds, the system will revert back to the previous display again. When the 'CL' indicator appears and flashes, please press the LED button on remote controller for 4 times or press the Manual control button for 3 or more times to clear the registered hours, otherwise the 'CL' indicator will display and flash again for another 15 seconds at the next time of starting the unit.

**Replacing filter reminding function:**

After 2880 hours of operation, the indoor display window will display and flash 'nF', this feature is a reminder to replace the Air Filter for more efficient operation. After 15 seconds, the system will revert back to the previous display again. When the 'nF' indicator appears and flashes, please press the LED button on remote controller for 4 times or press the Manual control button for 3 or more times to clear the registered hours, otherwise the 'nF' indicator will display and flash again for another 15 seconds at the next time of starting the unit.

**Mute operation(optional)**

Press the LED button on the remote controller can turn off the indoor screen display, and also turn off the Air conditioner buzzer, which create a comfortable and quiet environment.

**Care and Maintenance**

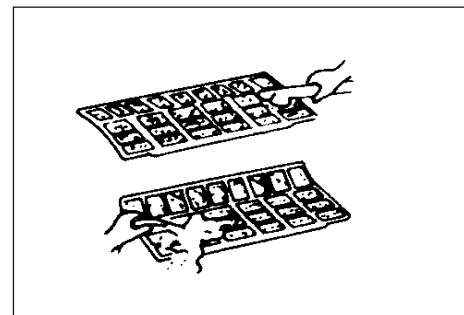
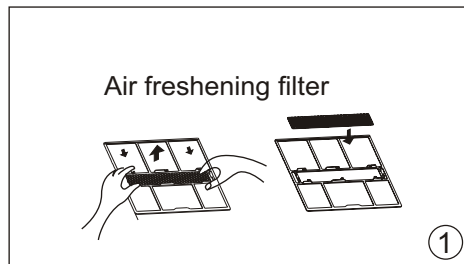
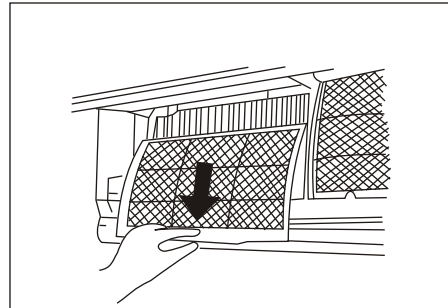
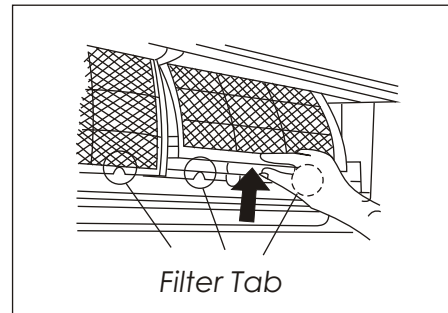
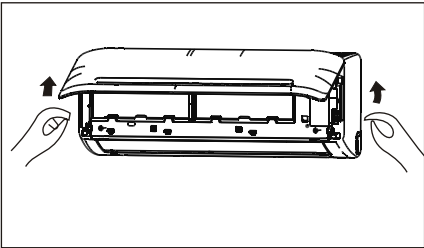

**Before maintenance**

- Turn the system off before cleaning. To clean, wipe with a soft, dry cloth. Do not use bleach or abrasives.

**NOTE: Power supply must be disconnected before attempting to clean or service!**

**CAUTIONS**

- Do not use a chemically treated cloth or duster to clean the unit.
- Do not use benzene, thinner, polishing powder, or similar solvents for cleaning. These may cause the plastic surface to crack or deform.
- Never use water hotter than 40°C/104°F to clean the front panel, it could cause deformation or discoloration.

**Cleaning the unit**

wipe the unit with a soft dry cloth only. If the unit is very dirty, wipe it with a cloth soaked in warm water.

**Cleaning the air filter and air freshening filter**

A clogged air filter reduces the cooling efficiency of this unit. Please clean the filter once every 2 weeks.

1. Open the front panel by carefully lifting both ends at the same time. At a certain angle, a clicking sound is heard and it becomes self-supporting. For some models, please use the suspension bars to prop up the panel.
2. Use the tab provided to move the filter first up a little, then slightly towards you. Now extract the filter by gently drawing downwards.
3. Unclip the small air freshening filter from the large air filter. Clean it with vacuum, and replace it occasionally.
4. Clean the large air filter with soapy water. Rinse with fresh water. Shake off excess water and dry it up in cool place, replace it occasionally.

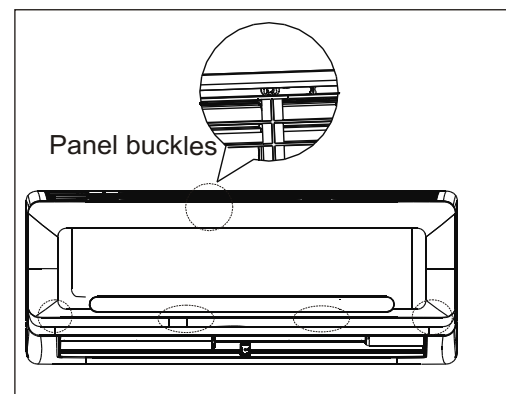
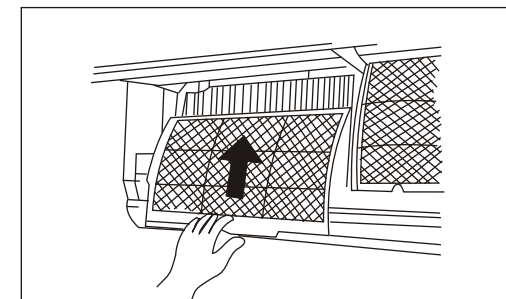
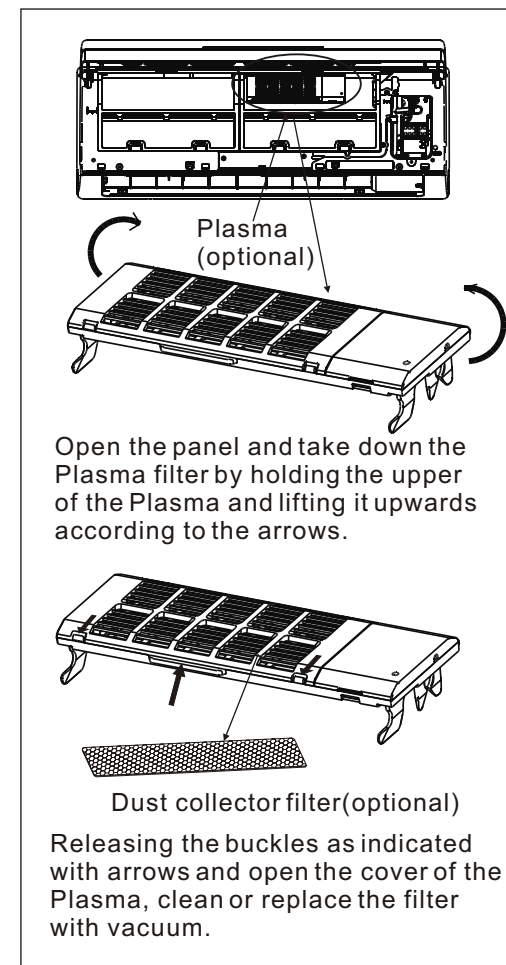

**!** For the models adopts Plasma, do not touch the plasma within 10 minutes after you open the panel. Clean the Plasma according to the description in the figure left.

5. Refit the small air freshening filter onto the large air filter.
6. Re-insert into unit in the reverse order described in point 2 above.
7. Close the front panel. Make sure the buckles are fully fit and the panel is completely closed.

**Preparation for extended non-operation**

If you plan to idle the unit for a long time, perform the following:

- (1) Clean the indoor unit and filters.
  - (2) Operate the fan for about half a day to dry the inside of the unit.
  - (3) Stop the air conditioner and disconnect power.
  - (4) Remove the batteries from the remote controller.
- The outdoor unit requires periodic maintenance and cleaning. Do not attempt to do this yourself. Contact your dealer or service provider.

**Pre-season inspection**

- Damaged or disconnected wires.
- Clean the indoor unit and filters.
- Check water or oil leaks.
- Check if the air outlet or inlet is blocked after the air conditioner has not been used for a long time.

**Caution**

- Do not touch the metal parts of the unit when removing the filter. Injuries can occur when handling sharp metal edges.
- Do not use water to clean inside the air conditioner. Exposure to water can destroy the insulation, leading to possible electric shock.
- When cleaning the unit, first make sure that the power and circuit breaker are turned off.
- Do not wash air filter with hot water at more than 40°C/104°F. Shake off moisture completely and dry it in the shade. Do not expose it directly to the sun, it may shrink.



**Troubleshooting tips**

The following events may occur during normal operation, and may not indicate malfunction.

Symptom	Cause
Operation is delayed after restart	To prevent blowout of the fuse, the compressor will not operate while the protection circuit is working for about 3 minutes after sudden OFF--ON operation of the power supply.
Fan speed changes-off, very slow and then normal	Automatically happens in heating mode : --prevents cold air blowing onto occupants when the heating operation is start, --perform automatic defrosting operation, --perform low temperature heating operation
Heating operation stops suddenly and defrost-light blinks	In HEAT mode, the indoor unit temporarily stops for maximum of 10 minutes to perform the automatic defrosting operation.
Mist coming out of the indoor unit	In COOL mode, a mist generated by condensation formed with sudden cooling process may be emitted. Mist may generate due to moisture generated from defrosting process when the air conditioner restarts in HEAT mode operation after defrosting.
Low volume sounds are emitted by the air conditioner	Hissing sound-- during operation or immediately after stopping the air conditioner, refrigerant flowing sound may be heard. Squeaking sound-- normal expansion and contraction of plastic and metal parts caused by temperature change during the operation. Rushing air-- when louver resets its position.
Dust discharges from the unit	May occur when air conditioner is used for the first time or has not been used for a long time.
Emits a peculiar odour	Various smells generated from interior textile, furniture, or cigarette smoke absorbed into the air conditioner may be emitted. If not the case call your suitable contractor.
Changes to fan only while cooling or heating mode	Room temperature reaches the temperature setting of the remote control. If not the case call your suitable contractor.
Operation is erratic, unpredictable or unresponsive	Interference from cell phone towers and remote boosters may cause the unit to malfunction Disconnect the power and then re-connect. Press the ON/OFF button on the remote controller to restart operation.

**NOTE:** If the problem is not resolved, please contact a local dealer or the nearest customer service center. Be sure to inform them of the detailed malfunctions and unit model number.

**Troubleshooting guide**

Before you call for or request servicing, troubleshoot a problem by performing following checks:

Symptom	Diagnostic
Unit will not operate	-- Is there a power failure?
	-- Has a switch been turned off, a circuit breaker tripped or a fuse blown?
	-- Is the timer operating?
	-- Are the batteries used in the remote controller exhausted? -- Are the batteries used in the remote controller loaded properly?
Poor cooling or heating performance	-- Are the air filters dirty?
	-- Is air flow unrestricted in & out of indoor & outdoor units?
	-- Are the temperature and mode settings correct?
	-- Are the windows or doors left opened?
	-- Is fan speed on high and louvers allowing maximum flow?
	-- Is direct or strong sunlight shining into the room in cooling operation? -- Are there other heating apparatus or computers operating, or too many people in the room in cooling operation? -- Is the "SILENCE" function(some units) is activated? Under "SILENCE" operation, noise reduction is prioritized and the air-conditioning performance may become lower.
Indicator lamps continue flashing	-- The unit may stop operation or continue to run in a safety condition (depending on models). Waiting for about 10 minutes, the fault may be recovered automatically, if not, disconnect the power and then connect it in again. If the problem still exists, disconnect the power and contact the nearest customer service center.
Error code appears in the indoor unit, such as: E0,E1,E2.... P1,P2,P3....or F1, F2, F3.....	

If the problem persists even if you perform these checks or diagnostics, immediately stop operation and contact the authorized service center. Be sure to inform them of the detailed malfunctions and unit model number.

**⚠ CAUTION**

**In the case of ANY of the following, turn off the unit immediately!**

- Power cord is damaged or abnormally warm.
- Burning odours are smelled.
- Loud or abnormal sounds are heard.
- A power fuse blows or a circuit breaker trips frequently.
- Water or other objects fall into or out of the unit.

**⚠ DO NOT ATTEMPT TO CORRECT THESE ITEMS YOURSELF!  
CONTACT A AUTHORIZED SERVICE PROVIDER!**



此面无需印刷：

说明书技术要求：

尺寸：**A4**

材质：**80克双胶纸**

颜色：黑白

装订