



# Mini Jacks Instruction Manual

**MODELS: J11050, J11055  
J11100  
J11200**

**-5 Ton Capacity  
-10 Ton Capacity  
-20 Ton Capacity**

SFA Companies 10939 N. Pomona Ave. Kansas City, MO 64153  
Tel: 888-332-6419 \* Fax: 816-448-2142  
E-mail: sales@bvahydraulics.com Website: www.bvahydraulics.com



This is the safety alert symbol. It is used to alert you to potential personal injury hazards. Obey all safety messages that follow this symbol to avoid possible injury or death.

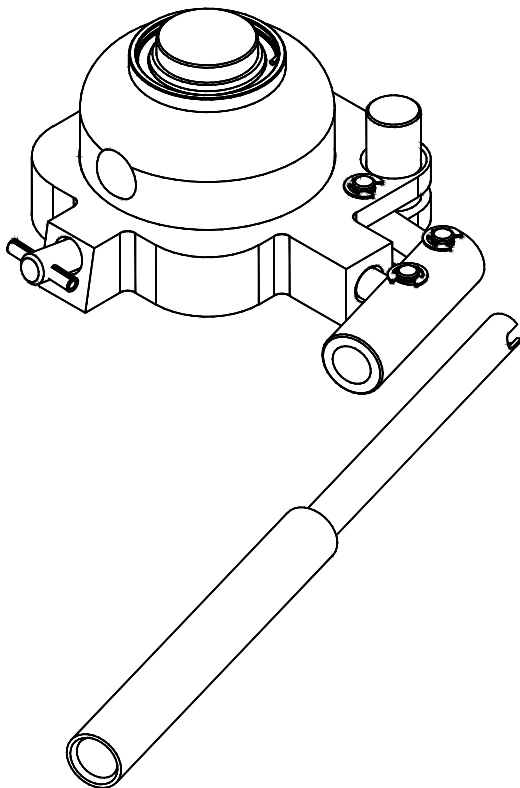

Model: J11050 & J11055

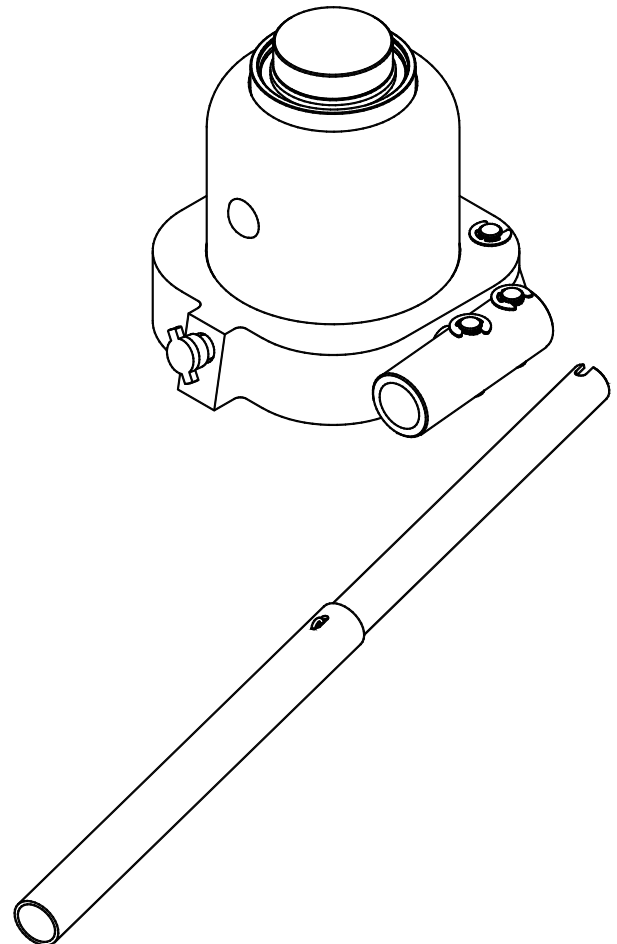

Model: J11100 & J11200

**Save these instructions.** For your safety, read, understand, and follow the information provided with and on this jack before using. The owner and/or operator of this equipment shall have an understanding of this jack and safe operating procedures before attempting to use. The owner and/or operator shall be aware that the use and repair of this product may require special skills and knowledge. Instructions and safety information shall be conveyed in the operator's native language before use of this jack is authorized. If any doubt exists as to the safe and proper use of this jack, remove from service immediately.

**Inspect before each use.** Do not use if broken, bent, cracked, or damaged parts (including labels) are noted. Any jack that appears damaged in any way, operates abnormally or is missing parts, shall be removed from service immediately. If you suspect that the jack was subjected to a shock load (a load dropped suddenly, unexpectedly upon it), immediately discontinue use until the jack has been checked by a BVA Hydraulics authorized service center (contact distributor or manufacturer for list of Authorized Service Centers). It is recommended that an annual inspection be done by qualified personnel. Labels and owner's manuals are available from manufacturer.

## PRODUCT DESCRIPTION

This product is designed to lift, position, or move, **but not sustain**, rated capacity loads. It is **not** designed to be used as a stand-alone device. Any load lifted, positioned, or otherwise moved by this device, must immediately be supported by appropriately rated mechanical means. A wide variety of applications exist for this category of product. Special skill, knowledge and training may be required for a specific task and this product may not be suitable for all jobs listed. Unsuitable applications include applications that call for a device to lift, position, move or support persons, animals, hazardous materials, mobile homes and dwellings in general, mirrors, plate glass or to connect/secure hatches, components, and materials between bulkheads. The user ultimately must make the decision regarding suitability of the product for any given task and therefore accept responsibility for that decision.

## HYDRAULIC JACK TECHNICAL SPECIFICATIONS

Rated Capacity of J11050, J11055: 10,000 lb. (5 ton)

Rated Capacity of J11100: 20,000 lb. (10 ton)

Rated Capacity of J11200: 40,000 lb. (20 ton)

Brand name: BVA

Hydraulic Pressure @ Rated Capacity:

J11050, J11055: 7,000 psi

J11100: 7,850 psi

J11200: 10,800 psi

## ⚠ WARNING

### To avoid personal injury and/or property damage:

- **Read**, understand and follow all printed materials provided with and on this jack.
- **This is a lifting device only! Never** work on, under, or around a load supported only by a hydraulic jack.
- **Immediately** support the lifted load with appropriately rated mechanical means.
- **Use only** on hard, level surfaces capable of sustaining rated capacity loads.
- Center load on saddle.
- No alteration shall be made to this device. Use **only** attachments, adapters and accessories provided by the manufacturer.
- **Be alert** and **sober** when using this product! **Never** operate this equipment when under the influence of drugs or alcohol.
- Use **only** high grade hydraulic jack oil in this product.
- **Always** use a calibrated means of determining how much force is being applied by this product. Never exceed the rated capacity of the jack.

## BEFORE USE

⚠ Before using this jack, ensure that the intended load contact point is able to withstand the load applied by this jack.

1. Before using this product, read the owner's manual completely and familiarize yourself thoroughly with the product, its components, and recognize the hazards associated with its use.
2. To familiarize yourself with basic operation, use the operating handle to engage and turn the release valve:
  - a. Clockwise until firm resistance is felt to further thread engagement. This is the '**CLOSED**' release valve position used to pressurize the hydraulic fluid and **raise** the ram plunger.
  - b. Counter-clockwise, but no more than 1/2 turn from the closed position. This is the '**OPEN**' release valve position used to **lower** the ram plunger.
3. Check that the pump operates smoothly before putting into service. Replace damaged or missing parts with factory authorized replacement parts only. Repair of this product may require special skills and knowledge and should only be attempted by a factory authorized service center. Contact the manufacturer or distributor of this product for a list of factory authorized service centers. Lubricate as instructed in Maintenance Section.

### Bleeding/ Venting Trapped Air

With the release valve in the OPEN position (2b above) and with saddle fully lowered, locate and remove the oil filler plug. Insert the handle into the handle sleeve; then pump 6 to 8 full strokes. This will help release any pressurized air which may be trapped within the reservoir. Oil level should be even with the bottom of the oil filler plug hole. Reinstall the oil filler plug.

⚠ *Use of this device may require special skills and knowledge. Read, understand, and follow **all** printed materials provided with and on this device before use.*

## SPECIFICATIONS

Model	Capacity (ton)	Min. Height (in)	Max. Height (in)	Base Size (LxW)	Weight (lb.)
J11050	5	2 3/8	3 1/8	4 1/8" x 4"	4.6
J11055	5	3 3/8	4 7/8	4 1/8" x 4"	5.3
J11100	10	4 3/4	6 1/4	4 7/8" x 4 3/8"	12.6
J11200	20	5 1/8	6 3/4	5 3/8" x 4 3/4"	16.7

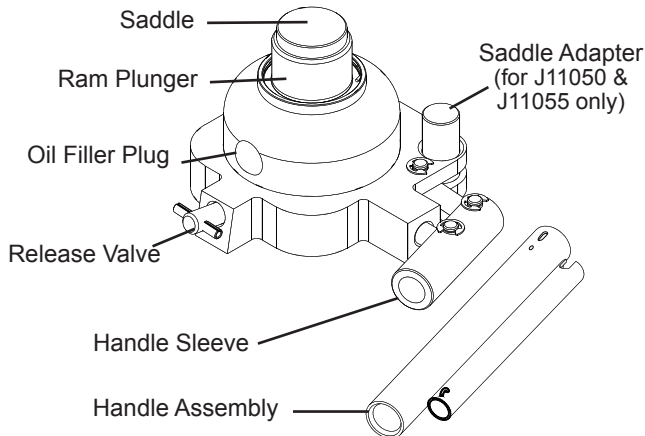

Figure 1 - Typical Mini Jack Components (J11050 shown)

### OPERATION

**▲ Use of this device may require special skills and knowledge. Read, understand, and follow all printed materials provided with and on this device before use.**

#### Raising the Ram Plunger

1. Locate and close release valve by turning handle clockwise until firm resistance is felt to further thread engagement.
2. Pump until load reaches desired height. **Immediately** secure with appropriately rated mechanical devices. It is recommended you follow the load with cribbing and blocking where practical.

**▲ Never allow personnel to work or pass under a load until the load is secured by cribbing, blocking, or other mechanical means.**

#### Lowering

**▲ Make certain that all personnel are clear of the load before lowering. Control the rate of descent of the load at all times. The more you open the release valve, the faster the load descends.**

1. Use the manufacturer's provided operating handle to engage and slowly turn the release valve counter-clockwise, but no more than 1/2 turn.

**▲ If the operating handle is damaged, operates abnormally, or will not positively engage the release valve, immediately discontinue use of the jack until a manufacturer's replacement handle assembly can be acquired.**

2. Push ram down and handle sleeve in to reduce exposure to rust and contamination after removing jack from under load.

### MAINTENANCE

**Important:** Use only good grade hydraulic jack oil. Avoid mixing different types of fluid and **NEVER** use brake fluid, turbine oil, transmission fluid, motor oil or glycerin. Improper fluid can cause premature failure of the jack and the potential for sudden and immediate loss of load. We recommend BVA FJZ01 or equivalent.

#### Adding

1. With saddle fully lowered set jack in its upright, level position. Locate and remove oil filler plug.
2. Fill with oil even with the bottom of the oil filler hole. Reinstall the oil filler plug.

#### Changing oil

For best performance and longest life, replace the complete fluid supply at least once per year.

1. With saddle fully lowered set jack in its upright, level position. Locate and remove oil filler plug.
2. Lay the jack on its side and drain the fluid into a suitable container.

**Note:** Dispose of hydraulic fluid in accordance with local regulations.

3. Fill with oil even with the bottom of the oil filler hole. Reinstall the oil filler plug.

#### Lubrication

A periodic coating of light lubricating oil to pivot points will help to ensure that pump piston linkages move freely.

**Note:** Never apply oil to saddle.

#### Cleaning

Periodically check the pump piston and ram plunger, and saddle for signs of rust or corrosion. Clean as needed and wipe with a clean, oil soaked rag.

**Note:** Never use sandpaper or abrasive material on these surfaces !

#### Storage

Store the jack with pump piston, ram plunger/saddle fully lowered and release valve open, but never more than 1/2 turn. This will help prevent rust and corrosion to those critical surfaces.



# Mini Jacks Service Parts

**MODELS: J11050 & J11055**

SFA Companies 10939 N. Pomona Ave. Kansas City, MO 64153  
Tel: 888-332-6419 \* Fax: 816-448-2142  
E-mail: sales@bvahydraulics.com Website: www.bvahydraulics.com

**Note:** Not all components of the jack are replacement items, but are illustrated as a convenient reference of location and position in the assembly sequence.

## Parts Illustration

(refer to **page 5** for parts list)

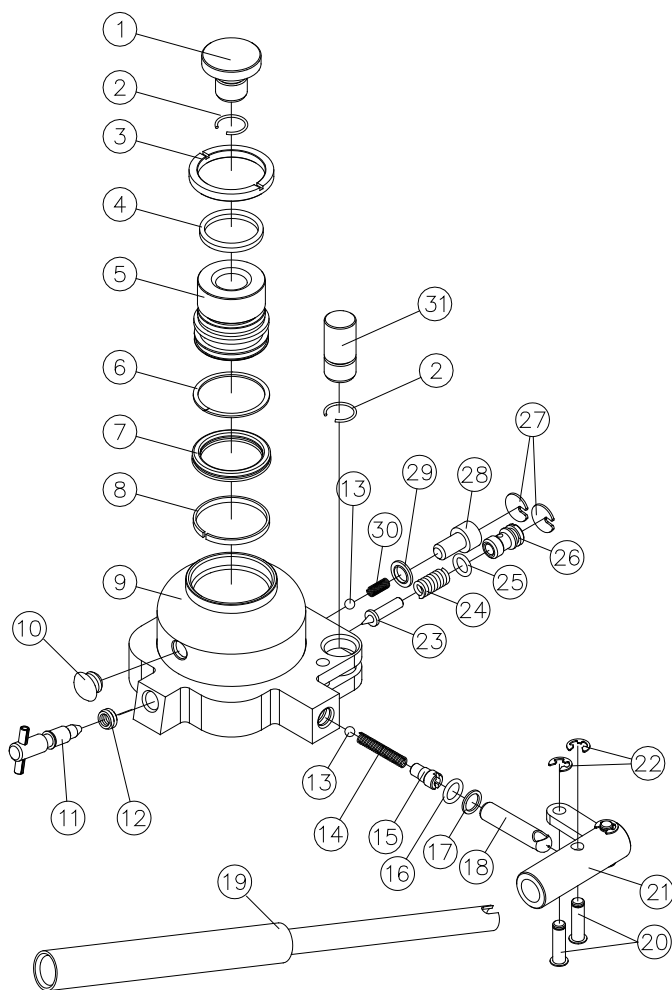

**Note:** To insure safe and reliable performance, replace worn or damaged parts with BVA Hydraulics authorized replacement parts only.



# Mini Jacks Service Parts

## MODELS: J11050 & J11055

SFA Companies 10939 N. Pomona Ave. Kansas City, MO 64153  
 Tel: 888-332-6419 \* Fax: 816-448-2142  
 E-mail: sales@bvahydraulics.com Website: www.bvahydraulics.com

**Note:** Not all components of the jack are replacement items, but are illustrated as a convenient reference of location and position in the assembly sequence.

### Parts List

Item	Model J11050	Model J11055	Description	Qty.
1	115-6-1103-104	115-6-1103-104	Saddle	1
2	115-6-1110-101	115-6-1110-101	Retaining Ring	2
3	115-6-1810-109	115-6-1810-109	Upper Bearing	1
4	580-7-0270-101	581-7-0268-000	Dust Seal	1
5	N/A	N/A	Ram Plunger	1
6	*	*	Back-up Ring	1
7	*	*	U-cup	1
8	599-7-0360-002	599-7-0360-002	Special Washer	1
9	N/A	N/A	Base Assy.	1
10	505-9-0092-207	505-9-0092-207	Oil Filler Plug	1
11	115-3-1700-104	115-3-1700-104	Release Valve	1
12	*	*	Oil Seal	1
13	601-7-0006-005	601-7-0008-009	Steel Ball	2
14	511-2-0052-001	512-2-0061-009	Spring	1
15	115-6-1603-104	115-6-1603-104	Screw	1
16	*	*	O-ring	1
17	*	*	Back-up Ring	1
18	115-6-1306-108	115-6-1306-108	Pump Piston	1
19	115-4-2100-101	115-4-2100-101	Handle	1
20	518-4-0060-102	518-4-0060-102	Pin	2
21	115-4-1300-104	115-4-1300-104	Handle Sleeve	1
22	677-5-0050-105	677-5-0050-105	"E" Clip	2
23	414-6-1216-107	414-6-1216-107	Needle	1
24	512-2-0067-010	512-2-0067-010	Safety Spring	1
25	*	*	O-ring	1
26	414-6-1215-307	414-6-1215-307	Safety Valve Screw	1
27	509-9-0145-109	509-9-0145-109	Safety Valve Cap	2
28	649-1-0080-027	649-1-0080-027	Socket Head Bolt	1
29	*	*	Gasket	1
30	511-2-0048-000	511-2-0048-000	Spring	1
31	115-6-1104-106	115-6-1104-106	Saddle Adapter	1
(*)	115-3-9901-104	115-3-9901-104	Repair Kit	-

(\*) - Indicates items included in, and available only as part of Repair Kit.

N/A - Part is not available as replacement.



# Mini Jacks Service Parts

**MODELS: J11100 & J11200**

SFA Companies 10939 N. Pomona Ave. Kansas City, MO 64153  
Tel: 888-332-6419 \* Fax: 816-448-2142  
E-mail: sales@bvahydraulics.com Website: www.bvahydraulics.com

**Note:** Not all components of the jack are replacement items, but are illustrated as a convenient reference of location and position in the assembly sequence.

## Parts Illustration

(refer to **page 7** for parts list)

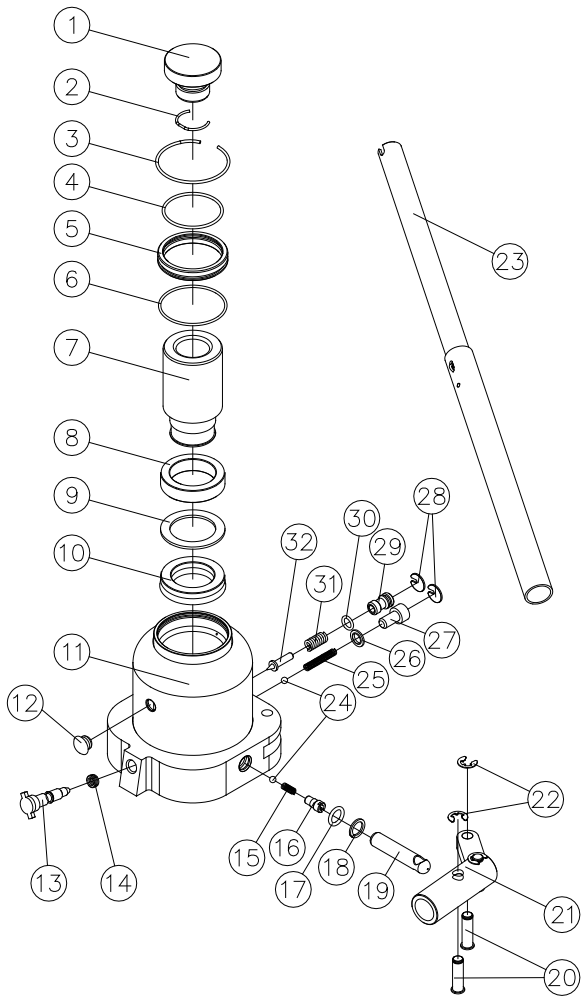

**Note:** To insure safe and reliable performance, replace worn or damaged parts with BVA Hydraulics authorized replacement parts only.



# Mini Jacks Service Parts

## MODELS: J11100 & J11200

SFA Companies 10939 N. Pomona Ave. Kansas City, MO 64153  
 Tel: 888-332-6419 \* Fax: 816-448-2142  
 E-mail: sales@bvahydraulics.com Website: www.bvahydraulics.com

**Note:** Not all components of the jack are replacement items, but are illustrated as a convenient reference of location and position in the assembly sequence.

## Parts List

Item	Model J11100	Model J11200	Description	Qty.
1	125-6-1103-102	135-6-1103-100	Saddle	1
2	A24-6-4302-107	430-6-4302-406	Retaining Ring	1
3	125-6-1808-100	226-6-1808-106	Retaining Ring	1
4	*	*	O-ring	1
5	125-6-1204-108	135-6-1204-106	Dust Seal	1
6	*	*	O-ring	1
7	N/A	N/A	Ram Plunger	1
8	125-6-1209-108	135-6-1209-106	Ram Bearing	1
9	*	*	Back-up Ring	1
10	*	*	U-cup	1
11	N/A	N/A	Base Assy.	1
12	505-9-0092-207	505-9-0092-207	Oil Filler Plug	1
13	238-6-1701-403	238-6-1701-403	Release Valve	1
14	*	*	Oil Seal	1
15	511-2-0052-001	512-2-0052-008	Spring	1
16	115-6-1603-104	115-6-1603-104	Screw	1
17	*	*	O-ring	1
18	*	*	Back-up Ring	1
19	125-6-1306-106	125-6-1306-106	Pump Piston	1
20	518-4-0080-016	518-4-0080-016	Pin	2
21	125-4-1300-102	125-4-1300-102	Handle Sleeve	1
22	677-5-0070-101	677-5-0070-101	"E" Clip	2
23	125-4-2100-109	135-4-2100-107	Handle	1
24	601-7-0006-005	601-7-0006-005	Steel Ball	2
25	511-2-0048-000	511-2-0048-000	Spring	1
26	*	*	Gasket	1
27	649-1-0080-027	649-1-0080-027	Socket Head Bolt	1
28	509-9-0145-109	509-9-0145-109	Safety Valve Cap	2
29	414-6-1215-307	414-6-1215-307	Safety Valve Screw	1
30	*	*	O-ring	1
31	512-2-0067-010	512-2-0067-010	Spring	1
32	414-6-1216-107	414-6-1216-107	Needle	1
(*)	125-3-9901-102	135-3-9901-100	Repair Kit	-

(\*) - Indicates items included in, and available only as part of Repair Kit.

N/A - Part is not available as replacement.

## TROUBLESHOOTING

Symptom	Possible Causes	Corrective Action
Jack will not pressurize	<ul style="list-style-type: none"> <li>• Release valve not tightly closed</li> <li>• Load is too heavy</li> </ul>	<ul style="list-style-type: none"> <li>• Ensure release valve tightly closed</li> <li>• Consider higher capacity jack</li> </ul>
Jack *bleeds off after lift * 'bleeds off' means load slowly and unintentionally lowers after lifting	<ul style="list-style-type: none"> <li>• Hydraulic unit malfunction</li> </ul>	<ul style="list-style-type: none"> <li>• Contact Service Center</li> </ul>
While lowering, fluid leaks from reservoir area Jack saddle will not descend to lowest advertised height	<ul style="list-style-type: none"> <li>• Reservoir overfilled</li> <li>• Ram plunger/cylinder deformed, seized up in ram cylinder and/or top nut, likely the result of off-center loading</li> </ul>	<ul style="list-style-type: none"> <li>• Drain fluid to proper level</li> <li>• Contact Service Center</li> </ul>
Ram plunger will not remain lowered after released from contact with load (creeps back up)	<ul style="list-style-type: none"> <li>• Air trapped in system</li> </ul>	<ul style="list-style-type: none"> <li>• Follow the Owners Manual instructions for bleeding air from system.</li> </ul>
Poor lift performance	<ul style="list-style-type: none"> <li>• Fluid level low</li> <li>• Air trapped in system</li> <li>• Hydraulic unit malfunction</li> </ul>	<ul style="list-style-type: none"> <li>• Ensure proper fluid level</li> <li>• Follow the Owners Manual instructions for bleeding air from system.</li> <li>• Contact Service Center</li> </ul>
Will not lift to full extension	<ul style="list-style-type: none"> <li>• Fluid level low</li> </ul>	<ul style="list-style-type: none"> <li>• Ensure proper fluid level</li> </ul>

## LIMITED LIFETIME WARRANTY

BVA Hydraulics®, represented in the United States by SFA Companies ["SFA"] warrants this product to be free from defects in material and workmanship for the life of the product as long as the original purchaser owns the product. The warranty is non-transferable and is subject to the terms, exclusions, and limitations described below:

- Damaged components, including but not limited to bent rams, dented or crushed cylinder walls, broken welds or couplers as well as worn out seals, o-rings and springs are the result of misuse and not covered by warranty and BVA Hydraulics will not provide any warranty credit for such damaged components.
- This warranty does not cover ordinary wear and tear, overloading, alterations (including repairs or attempted repairs not performed by BVA Hydraulics or one of its authorized personnel), improper fluid use, or use of the product in any manner for which the product was not intended or the use of which is not in accordance with the instructions or warnings provided with the product.
- In the unlikely event that a BVA Hydraulics product fails due to material defect in workmanship, you may contact SFA for disposition. In such cases, the customer's sole and exclusive remedy for any breach or alleged breach of warranty is limited to the repair or replacement of the defective product.
- Under no circumstances is BVA Hydraulics liable for any consequential or incidental damage or loss whatsoever.
- THIS WARRANTY IS LIMITED TO NEW PRODUCTS SOLD THROUGH AUTHORIZED DISTRIBUTORS AND OTHER CHANNELS DESIGNATED BY BVA HYDRAULICS. NO AGENT, EMPLOYEE OR OTHER REPRESENTATIVE OF BVA HYDRAULICS IS AUTHORIZED TO MODIFY THIS WARRANTY.
- THE FOREGOING IS EXCLUSIVE AND IS IN LIEU OF ALL OTHER EXPRESS AND IMPLIED WARRANTIES, INCLUDING BUT NOT LIMITED TO THE IMPLIED WARRANTIES OF MERCHANTABILITY AND FOR A FITNESS FOR A PARTICULAR PURPOSE.
- Components not manufactured by BVA Hydraulics including certain motor systems, gasoline engines, and others are not covered by this warranty and instead are covered by the manufacturer's separate manufacturer's warranty provided in the package.
- BVA Hydraulics' liability in all cases is limited to, and will not exceed the purchase price paid for the product.



SFA Companies  
10939 N. Pomona Ave. Kansas City, MO 64153  
Tel: 888-332-6419  
E-mail: sales@bvahydraulics.com