

**GENERATION 3 PRO**



I N S T R U C T I O N M A N U A L

**YOU ARE MOMENTS AWAY  
FROM USING THE FINEST  
KNIFE SHARPENER IN THE  
WORLD. MADE OF TOP QUALITY  
MATERIALS AND STATE OF THE  
ART MANUFACTURING, THE  
WICKED EDGE PRECISION  
KNIFE SHARPENER WILL CHANGE  
THE WAY YOU THINK ABOUT  
SHARPENING KNIVES. IT IS THE  
CHOICE OF PROFESSIONALS.**

**wickededge**  
precision knife sharpeners

W W W . W I C K E D E D G E U S A . C O M

## C O N G R A T U L A T I O N S !

Hi, I'm Clay Allison, developer of the Wicked Edge Precision Sharpener, and I want to thank you for your purchase and welcome you to the Wicked Edge community. I know you'll enjoy what this fine machine can do for your knives and I sincerely hope you, your kids and grandkids get many years of great results and enjoyment from it. A lot of care has gone into the design and manufacturing of our sharpeners and we've been helped immensely by feedback from within our community so that the machine is constantly evolving and getting better. Our team here at Wicked Edge are entirely dedicated to ensuring the satisfaction of each and every customer. If there is something you need, please let us know.

You'll find that our website is a great resource with a thriving forum, a burgeoning Wiki and a quickly growing database of knives and their Wicked Edge settings. The forum in particular is filled with thousands of passionate sharpeners that know all kinds of great tips and tricks for the Wicked Edge. You'll find the culture is very open and welcoming, and people are sharing information and learning from each other constantly. I hope you'll log on and create an account so you can participate in the lively discussions happening daily. There are a large, and increasing, number of videos under the Demo section where you can see the sharpener in action and learn about various, sharpening specific, skills. Our tech support crew is available by phone and email and is very enthusiastic about helping you get the most from your Wicked Edge.

## A FEW POINTERS TO GET YOU STARTED

**1. Choosing your angle** - If you're new to sharpening, it's probably best to match the angles already ground onto your knife. You can easily find what those are by coloring in the bevel with a marker and observing how much marker comes off when you're using the stones. Please see page 12 for detailed instructions on discovering your knife's angle. Located in the website's [Instructions](#) section, you'll find a complete tutorial on using a marker to find your angle.

**2. Drawing and detecting a burr** - In order for a knife to be truly sharp, both bevels' planes need to intersect at a fine point or apex. To verify that the bevels meet, it's important to draw a burr from each side of the knife along the entire length of the blade. You should do this when you're first getting started with a knife while using the coarser grits. Please see page 18 for detailed instructions for drawing and detecting a burr. Also in the website's [Instructions](#) section is a complete tutorial on drawing and detecting a burr.

**3. Letting your stones break in** - Your new diamond plates will be very aggressive at first and will need to have a lot of the extra, loose diamonds knocked off. The best way to do this is to work on a few inexpensive knives. As you perfect your technique, you'll also break in your stones and your results will continue to get better and better. I can't really overstate the necessity of letting your stones break in. The difference in edge quality you'll achieve as your stones hit their stride is significant.

## A FEW POINTERS TO GET YOU STARTED

**4. Pressure** - Don't use too much! For most applications, you'll want to use only the weight of the stones themselves against the blade. There are exceptions, like when you want to remove a lot of metal and change the angles of the blade, but for the most part, a light touch is your friend.

**5. Safety** - You're knives will get very sharp with the Wicked Edge and extra care needs to be taken to prevent cuts. Don't leave a knife clamped in the machine when you're not actively using it, and don't reach across the machine when a knife is mounted. Always pay attention to what you're doing when operating the sharpener and don't let yourself become distracted.

Thank you again for choosing Wicked Edge and please let me know if there is ever anything I can do for you.

Sincerely,

A handwritten signature in white ink that reads "Clay Allison". The signature is written in a cursive, flowing style.

Clay Allison

## TABLE OF CONTENTS

<b>Anatomy of a Knife</b> .....	Pg. 7
<b>In the Box</b> - Numbered Parts List .....	Pg. 8
<b>Getting Started</b> - Setting up your Generation 3 Pro Sharpener .....	Pg. 9
<b>Mounting Your Knife</b> - Getting familiar with your new sharpener .....	Pg. 10, 11
<b>Setting the Angle</b> - Matching the existing angle or choosing your own .....	Pg. 12, 13
<b>Correct Positioning</b> - Knife placement and finding the "Sweet Spot." .....	Pg. 14, 15
<b>Recording Your Settings</b> - 3 steps necessary for angle repeatability .....	Pg. 16
<b>Basic Sharpening</b> - Sharpening your knife for the first time with the Wicked Edge .....	Pg. 17
<b>Creating and Detecting a Burr</b> - Critical step for success .....	Pg. 18
<b>Progressing Through Your Stones</b> - Sharpening motion and breaking in your stones .....	Pg. 19
<b>Removing Your Knife</b> - Safely remove your knife from the sharpener .....	Pg. 19
<b>Touching Up Your Knife</b> .....	Pg. 20
<b>Knife Sharpening Tables</b> - Track your knives for fast touch-ups .....	Pg. 21, 22
<b>Knife Sharpener Warranty</b> .....	Pg. 23

# ANATOMY OF A KNIFE

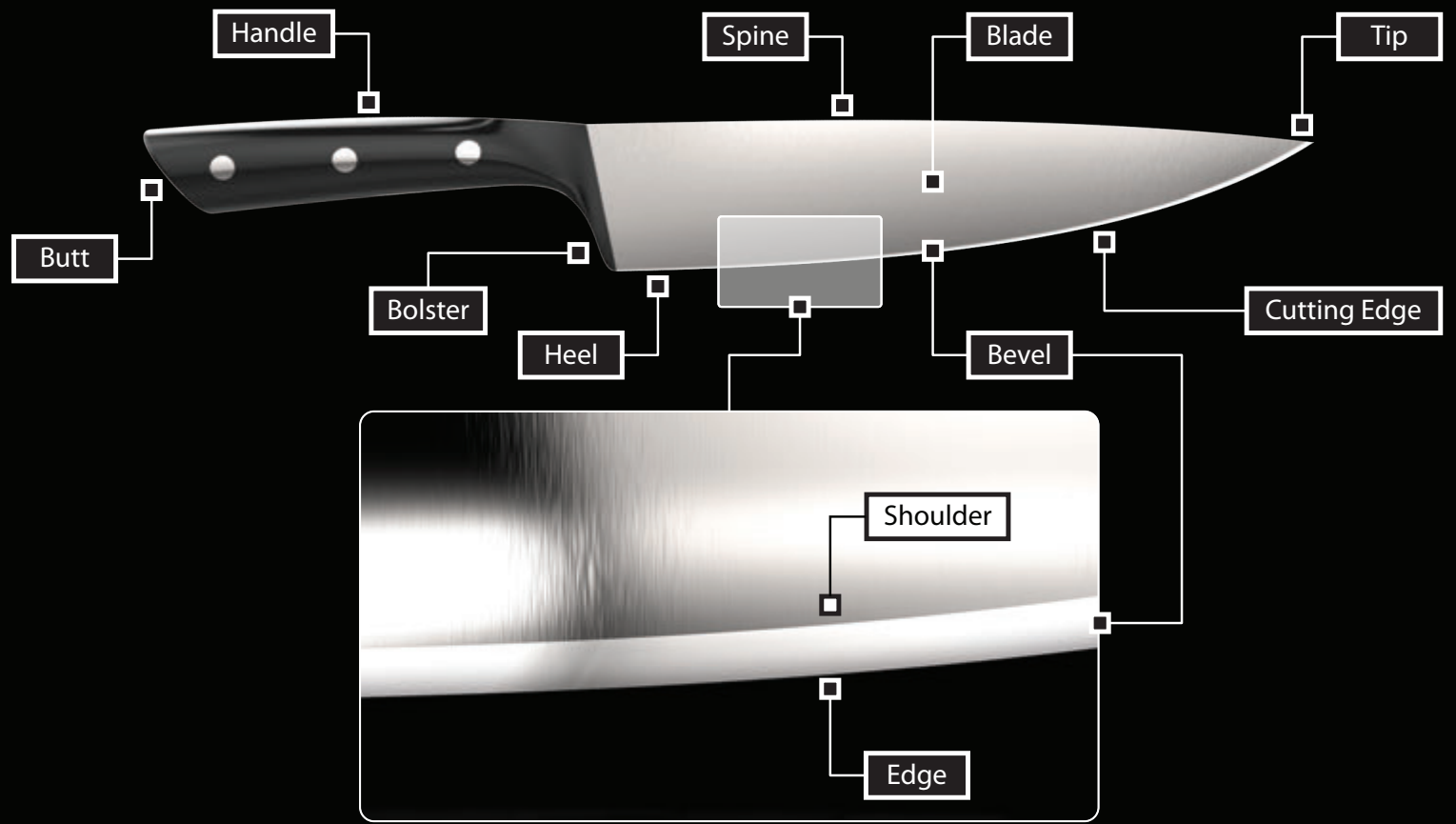

*Bevel Detail*

## IN THE BOX

Please check to ensure you have all of the components of your sharpener. You should have each of the items listed here in the quantity shown in parentheses.

1. Vise Jaw
2. Two Depth Settings for Repeatable Mounting
3. Depth Key
4. Vise Lever / Vise Lever Block
5. Thumb Screw for Vise Lever
6. Ball Jointed Guide Rod (2)
7. Numbered Angle Settings
8. Angle Lever
9. Shelf for Sharpening Stones (2)
10. Alignment Guide
11. Guide Rod Post
12. 1/8" Allen Wrench for Micro-Adjustment
13. Coarse 100 Grit / Medium Coarse 200 Grit Diamond Stones Pack
14. Medium 400 Grit / Fine 600 Grit Diamond Stones Pack
15. Extra Fine 800 Grit / Ultra Fine 1000 Grit Diamond Stones Pack

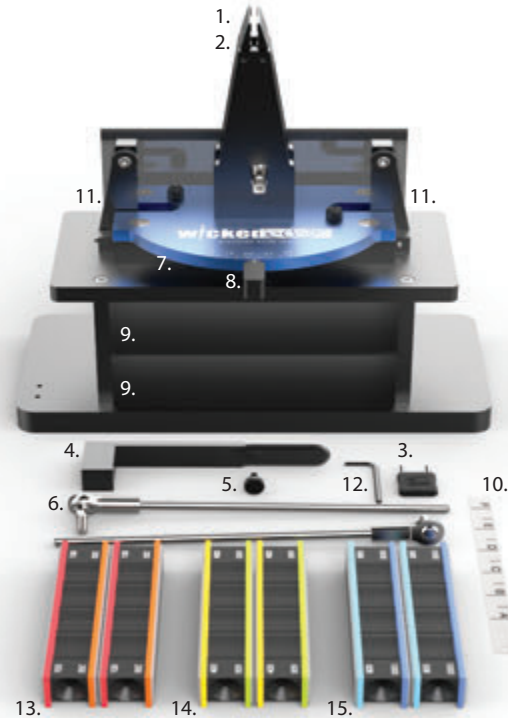



## GETTING STARTED

**Step 1:** Use the #12 1/8" Allen Wrench to insert the #6 Ball Jointed Guide Rods into the #11 Guide Ros Posts. The Guide Rods should be mounted so the Ball Joints are on the inside of the Posts, towards the sharpener, as shown in *Figure 2*.

**Step 2:** Attach the #4 Vise Lever to the sharpener by sliding the square hole on the Vise Lever Block onto the square Cam Shaft, which is located toward the bottom of the #1 Vise Jaw, as shown in *Figure 2*. When attached, the lever should be to the right of the #1 Vise Jaw. Use the #5 Thumb Screw to secure the Vise Lever onto the Sharpener.

**Step 3:** Place your sharpening stones onto the #9 Shelves for easy access while sharpening.

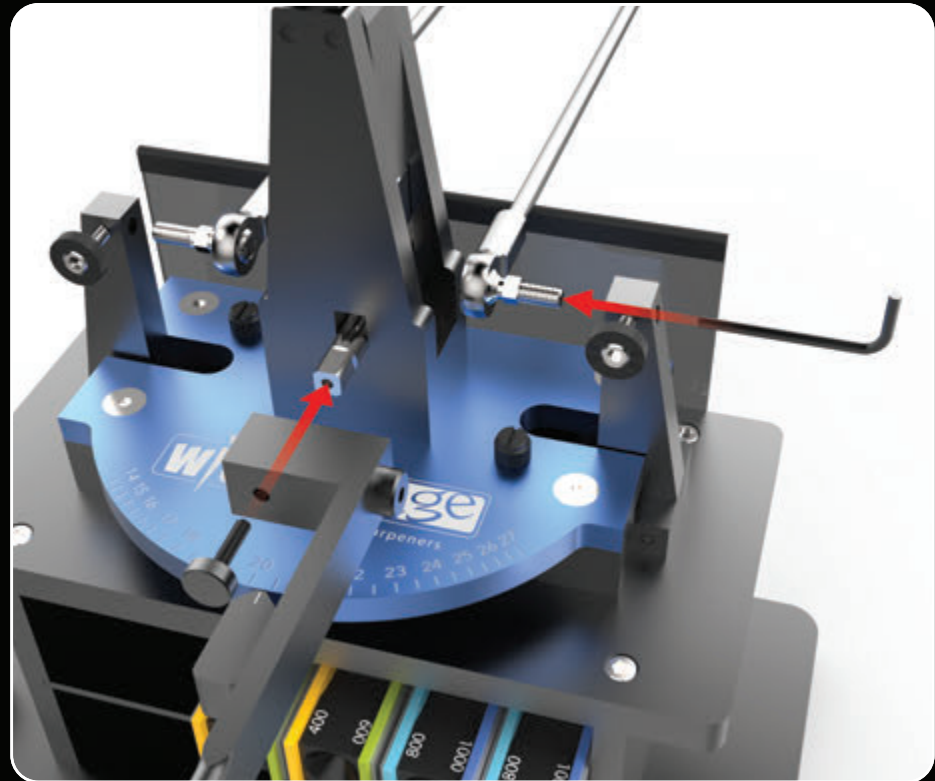

*Fig. 2*

## MOUNTING YOUR KNIFE

Attach the #10 Alignment Guide to the #3 Depth Key and insert the two prongs of the Depth Key into one of the two #2 Depth Settings located at the top of the Vise Jaw, as shown in *Figure 3*. (Hint: if you are sharpening a larger knife, use the bottom settings. If you are sharpening a smaller knife, use the top settings.)

Holding the knife so the tip is facing directly away from you and the edge is facing upward, mount the knife so it is approximately centered in the Vise Jaw. The spine of the knife should make contact with both prongs of the Depth Key as shown in *Figure 4*. If your knife does not have a flat spine, place it in the Vise Jaw so the tip and heel of the knife are level.

While firmly holding the knife with one hand, use your other hand to lift the Vise Lever up from its resting position against the Back Plate, as shown in *Figure 5*.

Push the Vise Lever all the way down, until the knife is secured in place, as shown in *Figure 6*.

On a scratch piece of paper, record the depth setting (top or bottom) and the alignment setting that is aligned with the tip of the knife. Then remove the Depth Key and Alignment Guide. (Hint: your settings may change after you find the correct positioning for your knife, which is why we recommend to use a scratch piece of paper during this step. We'll get to the correct positioning shortly.)

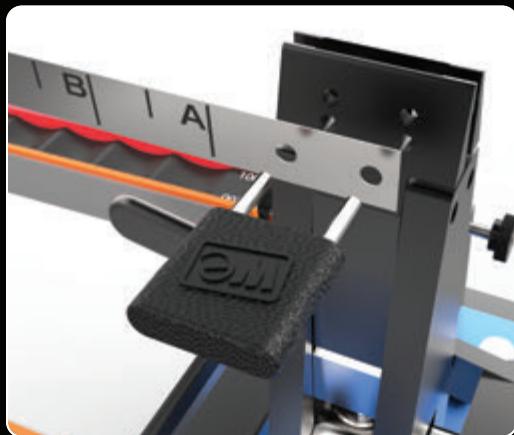

Fig. 3



Fig. 4



Fig. 5



Fig. 6

## SETTING THE ANGLE

There are three ways to find your angle.

1. Consult the manufacturers documentation
  2. Use a laser goniometer available from CATRA at [www.catra.org](http://www.catra.org)
  3. Use a marker to color in the bevel and observe how the stones remove the marker (recommended)
- You may also refer to the [Knife Database](#) located on our website to see if someone with a similar knife has recorded their settings.

This is the procedure for using a marker to find your angle:

Color in your bevel as shown in *Figure 7-1*.

Set a fine stone on the Guide Rod and lay it up against the bevel of the knife. Move the Angle Lever until the stone appears to lay flat against the bevel. Make a pass or two with the stone, as shown in *Figure 8* on the next page, and observe where the marker is removed. If the marker is removed from the bottom of the bevel, as shown in *Figure 7-3*, then the angle is too narrow. Move the Angle Lever to the next highest angle, as shown on *Figure 9* on the next page, and try again. If the marker is removed at the top of the bevel, as shown in *Figure 7-4*, the angle is too wide. Move the Angle Lever to the next lowest angle setting and try again. When you find the angle that allows the stone to remove the marker from the entire bevel with one pass, that is the angle of your edge.

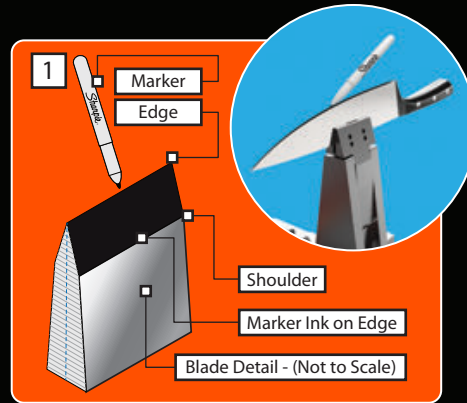

Fig. 7-1

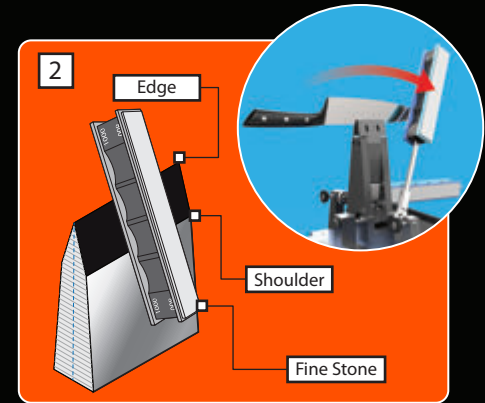

Fig. 7-2

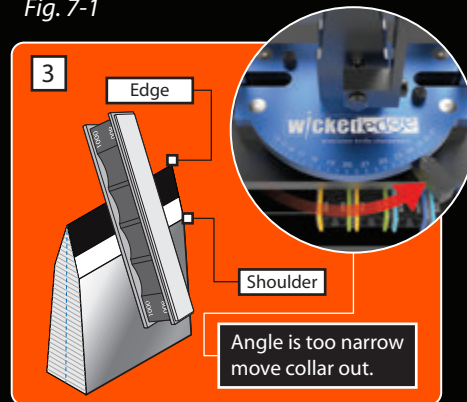

Fig. 7-3

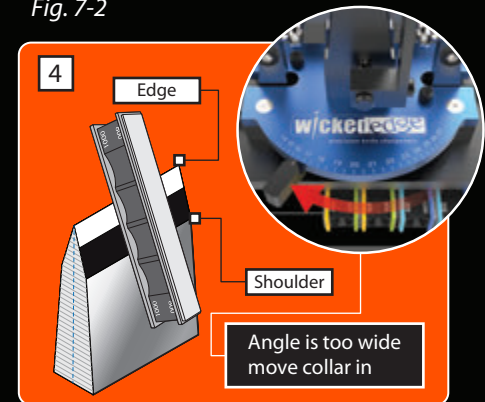

Fig. 7-4

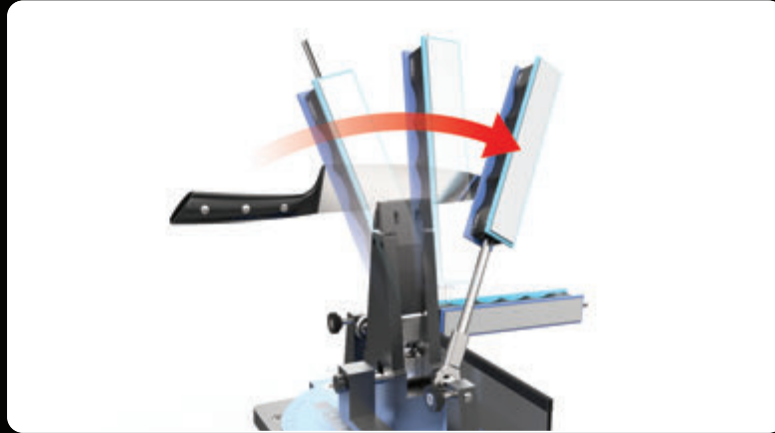

Fig. 8

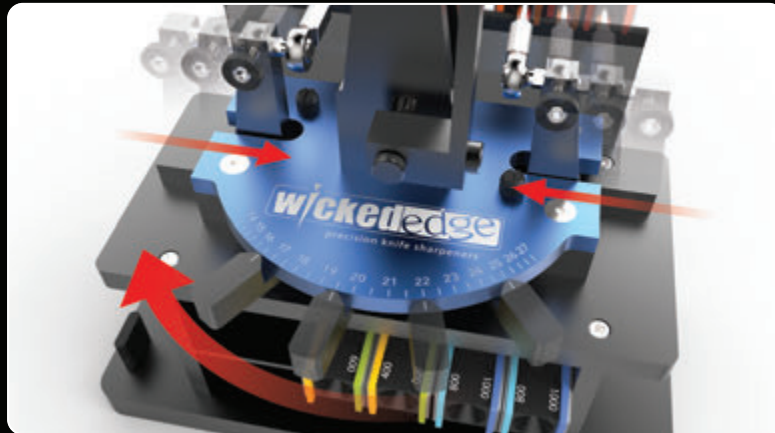

Fig. 9

## C O R R E C T P O S I T I O N I N G

The curvature of a knife is an important factor to consider when sharpening because it can effect the sharpening geometry, so it is important to position the knife correctly in the clamp. Doing so will let you keep your bevels even, from the heel of the knife to the tip.

The easiest way to find the optimal front-to-back positioning for a given knife is to, again, use a marker. Color in the entire bevel, on both sides. Then, lightly swipe a fine stone down the entire length of the blade to see where the marker is removed. Look closely to see how the stone effects the coloring on the edge. If the stone is removing the marker from the edge along the straight portion but dipping down along into the shoulder toward the tip, as shown in *Figure 10-2* on the next page, reposition the knife with the tip closer to the clamp. If the opposite happens – that the stone removes the marker at the shoulder of the bevel along the straight portion and then moves to the edge along the curve, as shown in *Figure 10-3* on the next page, then the knife should be repositioned with the tip further from the Vise Jaw. Once you find the position where the marker is removed evenly from the entire bevel, as shown in *Figure 10-4* on the next page, you have found the optimum positioning for your knife. Any time you reposition your knife, it is important to re-insert the Depth Key and Alignment Guide and re-record your settings.

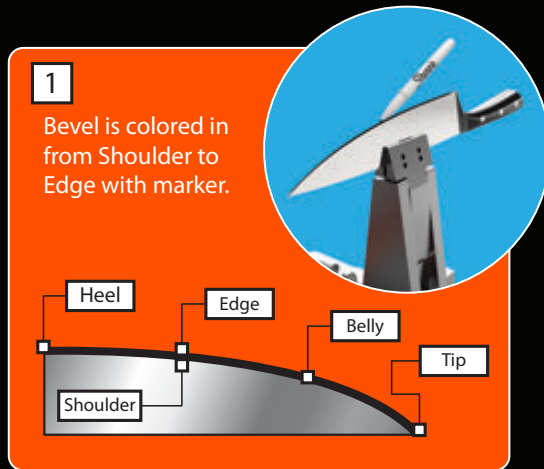

Fig. 10-1

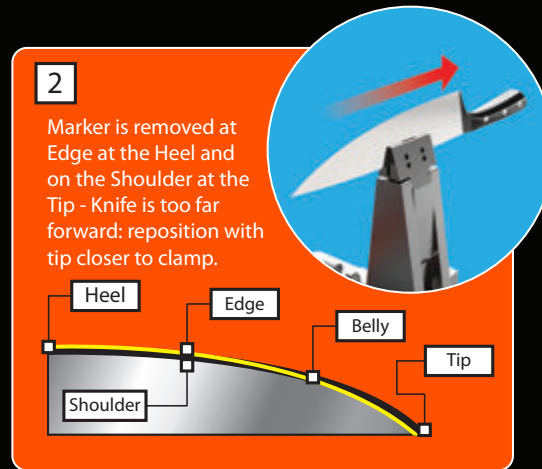

Fig. 10-2

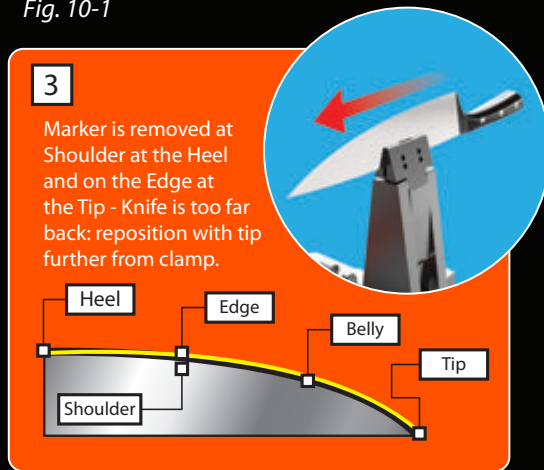

Fig. 10-3

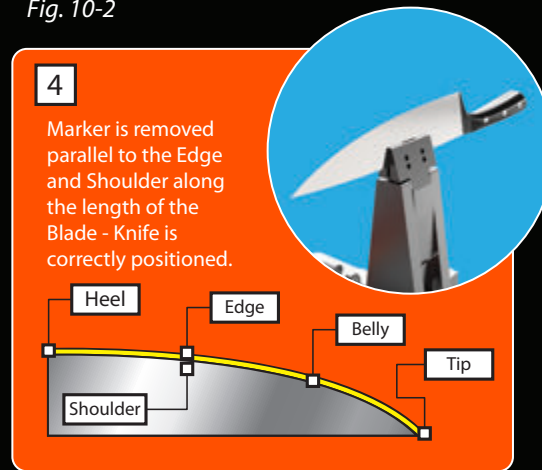

Fig. 10-4

## RECORDING YOUR SETTINGS

Recording your angle, alignment, and depth settings is a crucial step in the sharpening process. If your settings are recorded correctly you will be able to touch up your knives in less than a minute and remove virtually no metal. To record your angle settings, record the angle at which the Angle Lever is set. To record the depth, write that you have used either the top or bottom depth setting. For the alignment, look at the tip of the knife and compare it to the alignment guide. You can record your settings in the Knife Sharpening Table located on pages 21 and 22. You may also record your settings in the [Knife Database](#) on our website so others may use your settings. Once you have recorded your settings, remove the Depth Key and Alignment Guide from the Vise Jaw.

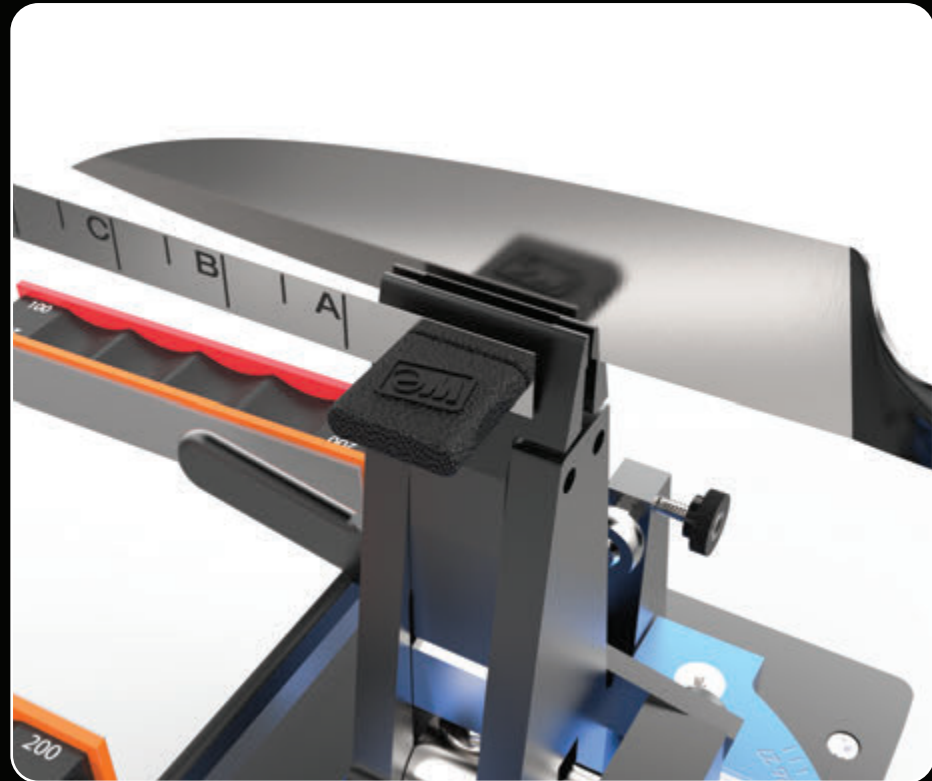

Fig. 11



## BASIC SHARPENING

If this is the first time your knife has been sharpened with a Wicked Edge Sharpener, or if you are changing the angle of the knife's edge, you will need to use the coarse stones to re-profile the edge. Again, mark the entire bevel of the knife, on both sides, with a marker. Slide the 100/200 Grit Diamond Stones Handles onto the Guide Rods. Grasp the handles with your fingers on the indentations, being careful to keep your finger tips behind the guards that the stones are mounted to. Place the top of the Red – 100 Grit Coarse Stone flat against the heel of the knife. Slide the stone up and away from you, along the entire bevel of the knife. The stroke is done when the bottom of the stone reaches the tip of the knife. Use alternating side-to-side strokes so both sides of the knife are sharpened at the same time. Sharpen until the marker is completely removed from the bevels.

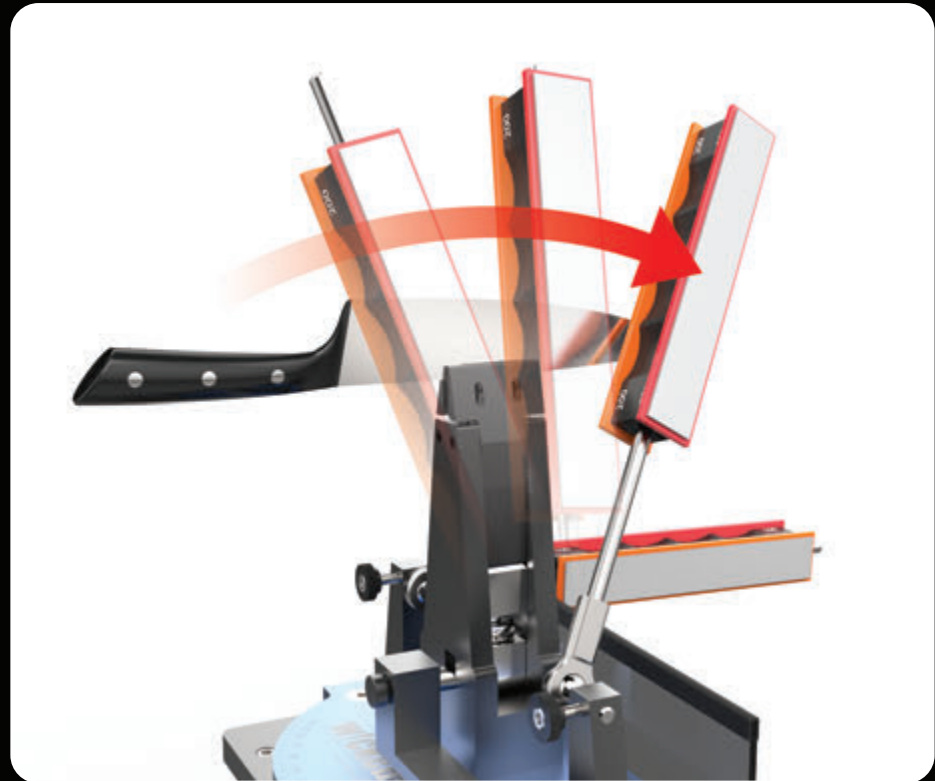

Fig. 12

## CREATING AND DETECTING A BURR

When you're first sharpening a blade, successfully drawing a burr from each side of the knife is the most important step. It is very difficult to know for certain without the presence of a burr if the bevels on each side of the blade actually extend to the edge. If the bevels do not extend all the way to the edge, the edge of the knife will be blunt and the knife will not be sharp. A burr, also called a wire edge, is created as a result of sharpening metal. The burr forms on the edge of a knife where the planes of bevels intersect. The diagram to the right shows the burr projecting from the edge of the knife:

Once all the marker has been removed from the bevel, try to create a burr on one side of the knife by sharpening the opposite side only. Do approximately 10 strokes on one side of your knife only and then check the opposite side for a burr. You can do this by very carefully feeling the side of the blade by rubbing your fingernail or a cotton ball up the opposite side of the knife, from the spine toward the edge. If you feel it snag on the edge, the burr has been properly formed. Make sure the burr exists throughout the entire length of the knife. Different areas of the knife may require more strokes to successfully form a burr. Do as many strokes as necessary to detect a burr along the entire edge. Once you've successfully created and detected a burr on one side of the knife, repeat the procedure for the other side.

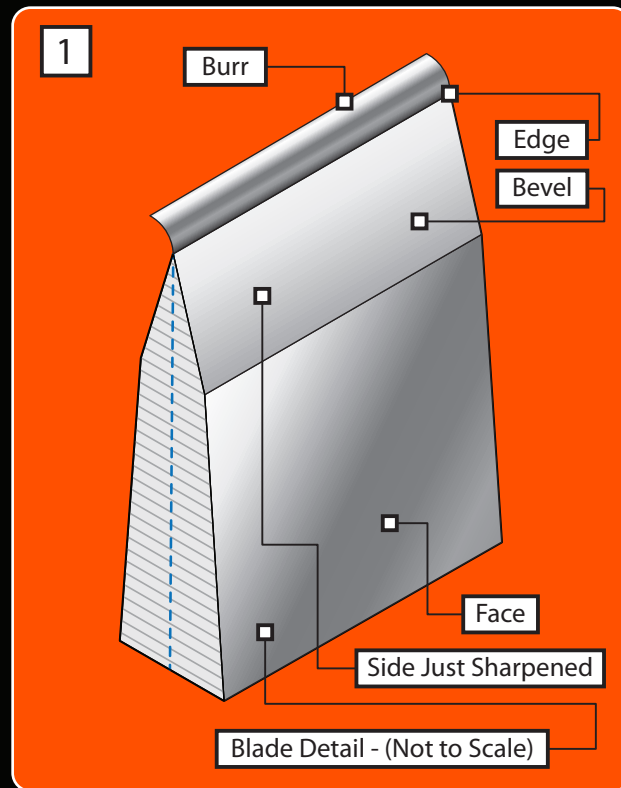

Fig. 13

## PROGRESSING THROUGH YOUR STONES

Once you've successfully created and detected a burr from both sides of the blade, sharpen your knife using alternating side-to-side strokes. Progress through your grits until you achieve the level of polish desired. Note that your stones will need time to break in. We recommend sharpening your inexpensive knives first to let your stones break in. As you spend time using your Wicked Edge Sharpener your technique will become more fluid, your stones will break in, and your results will improve with every knife.

To remove the knife from the sharpener, firmly grasp the handle of the knife with one hand, while loosening the bottom screw of the vice. Carefully remove the knife. If necessary, loosen the top screw as well.

Congratulations, you now have a Wicked Edge on your knife!

### REMOVING YOUR KNIFE

Be careful! Your knife is extremely sharp. **FIRMLY** hold the handle of the knife with one hand and use your other hand to move the Vise Jaw Clamping Lever to its up position to release the knife, as shown in *Figure 14*.



Fig. 14

## TOUCHING UP YOUR KNIFE

When your knife starts to become dull, it's time for a touch-up. The amount of time between touch-ups can vary, depending on the steel, angle, and usage. To bring your edge back to incredible sharpness we recommend starting your grit progression with your finest diamond stone. Simply reference your recorded settings for that particular knife. Mount your knife so the depth, alignment, and angle settings are identical to that which you set during that knife's previous sharpening session. Once everything is set, draw a burr from one side. Then sharpen the opposite side and push the burr to the other direction. Once you have found the burr on both sides, do approximately 20 strokes with your diamond stones, on each side of the knife. If you have purchased any additional fine stones or strops, progress through them until you reach a level of sharpness and polish that you are happy with.

### WE'RE HERE TO HELP!

If you have any questions please feel free to email or call us.

Here's our contact info:

Email: [Support@wickededgeusa.com](mailto:Support@wickededgeusa.com)

Toll Free: (877) 616-9911

Hours: 9:00 A.M. To 5:00 P.M. Mountain Time

## WICKED EDGE® KNIFE SHARPENING TABLE

Brand	Model	Angle	Mark	Depth
<i>Sample</i>	<i>10xx</i>	<i>22</i>	<i>C 0.5</i>	<i>Top</i>

Brand	Model	Angle	Mark	Depth

# WICKED EDGE® KNIFE SHARPENING TABLE

Brand	Model	Angle	Mark	Depth

Brand	Model	Angle	Mark	Depth

## WICKED EDGE® KNIFE SHARPENER WARRANTY

### **STOP!! BEFORE USING THIS PRODUCT YOU MUST READ THE FOLLOWING PRODUCT WARRANTY, DISCLAIMERS AND WARNINGS!!**

Wicked Edge® (a division of HollowPoint, LLC) offers a Limited Lifetime Warranty to the purchaser of the knife sharpener, for defects in materials and workmanship. The knife sharpener is not made for, designed for, nor intended to be, used for any purpose other than as specified in the Instructions. Any use of the knife sharpener, for any activity whatsoever, other than that for which the knife sharpener was intended, is done at the purchaser's own risk. The knife sharpener is to be used only with knives in good condition that are not damaged or otherwise faulty. It is the purchaser's sole responsibility to read the Instructions thoroughly. Extreme care must be used when installing, mounting and using the knife sharpener to avoid serious accident, injury, or death. Wicked Edge® will not be responsible for damage to the knife sharpener while being mounted. By purchasing the knife sharpener, the purchaser agrees and acknowledges that the knife sharpener is an inherently dangerous tool that can cause injury, even in the course of ordinary use, and even if used for the purpose for which the knife sharpener was intended. Therefore, the purchaser agrees and acknowledges that Wicked Edge® cannot be responsible or liable in any way for injury, accident, bodily harm (including death) or other such trauma that may arise out of the purchaser's use or misuse of the knife sharpener, whether used in the course of sharpening knives or otherwise, regardless of whether such use was for the purpose for which the knife sharpener was intended.

THE PURCHASER HEREBY EXPRESSLY RELEASES WICKED EDGE®, ITS EMPLOYEES, AGENTS, OFFICERS, DIRECTORS AND MEMBERS, FOR ANY AND ALL LIABILITY, INCLUDING DAMAGES, INJURY, ACCIDENT, BODILY HARM (INCLUDING DEATH) OR OTHER SUCH TRAUMA, THAT MAY RESULT FROM PURCHASER'S USE OR MISUSE OF THE KNIFE SHARPENER, OR USE OR MISUSE OF KNIVES IN CONNECTION WITH THE KNIFE SHARPENER.

Wicked Edge's® obligation under this warranty is limited to the replacement of the knife sharpener only. All costs related to the removal, installation or re-installation of the knife sharpener, freight charges, incidental or consequential damages, are expressly excluded from this warranty. This warranty is expressly in lieu of all other warranties, expressed or implied. This warranty SHALL NOT apply to any knife sharpener that has been subject to accident, negligence, alteration, abuse or misuse as determined at the sole discretion of Wicked Edge®

Wicked Edge®  
1591 Pacheco Street, Bldg 2  
Santa Fe, NM 87505 USA  
(877) 616-9911

©2015 Wicked Edge® All Rights Reserved.



W W W . W I C K E D E D G E U S A . C O M