

## SHIFTER 1968-69 Camaro

- SW1001 TH350/TH400
- SW1011 4-Speed Overdrives
- SW1021 4L80E
- SW1025 6L80E/6L90E

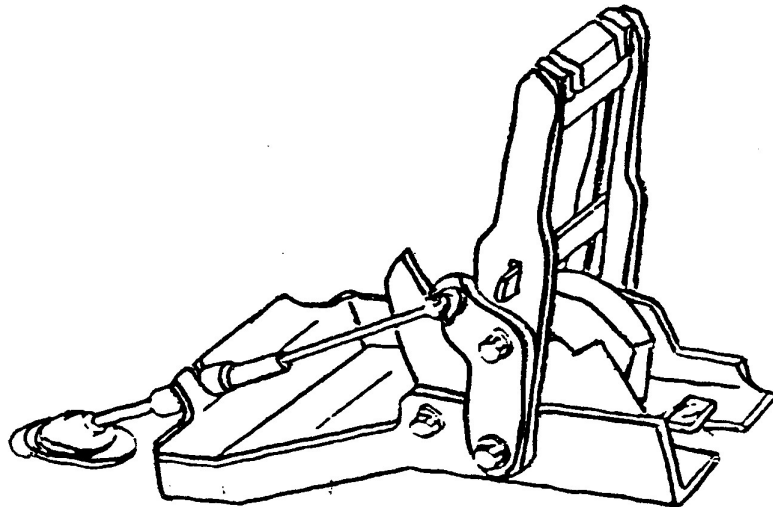

Kits convert the factory Automatic console shifter to OverDrive Operation with all gears available. Some of the **4LxxE** Series transmissions use a Long Range Select Shaft to add an external Neutral Safety Switch to the Transmission. Use of the longer shaft requires a non-offset lever, included in this kit. SHIFTWORKS®.

[www.shiftworks.com](http://www.shiftworks.com)  
© 1991-2023 SHIFTWORKS®

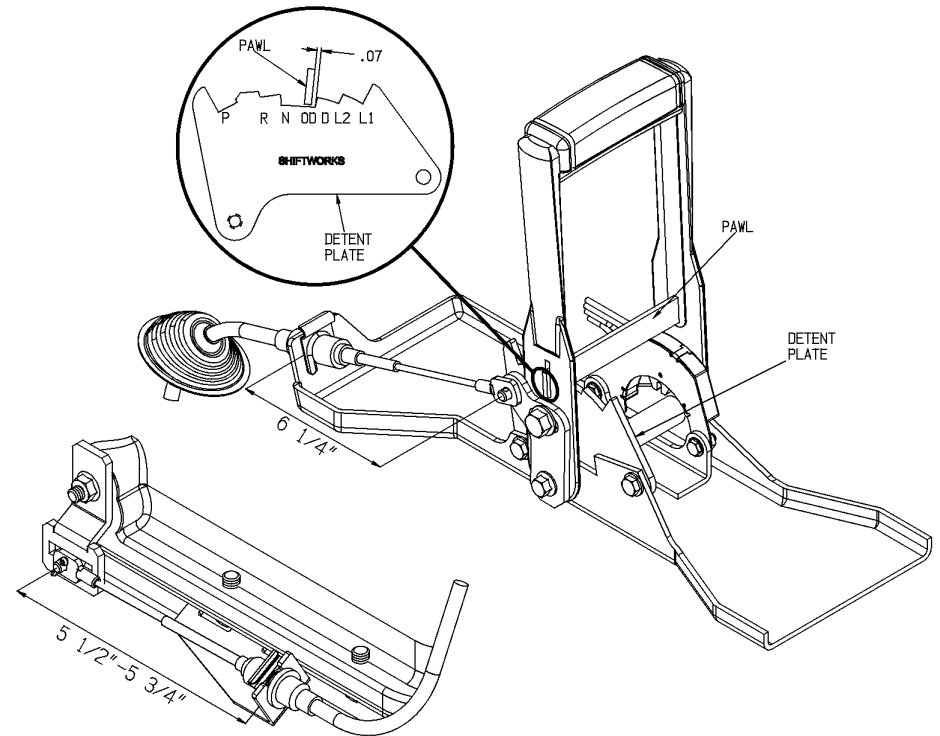

### MANUAL LINKAGE ADJUSTMENT

1. Remove console and install new shifter.
2. Install the new pan bracket and shift control lever on the transmission.
3. Install the cable. The cable is adjusted at the transmission by moving the pin in the shift control lever.
4. Put **BOTH** the Transmission and the Shifter in OverDrive. The distance from the pin to the face of the pan bracket should be about 5.5" to 5.75". Adjust so that the cable eyelet can be freely removed when in gear and so that the shift handle is properly engaged.
5. Use SHIFTWORKS® Cable #K100-30 or GM Cable #3956765. No other reproduction cables are recommended.