

SHIFTWORKS®

TH350 & TH400

IMPALA

SHIFTER CONVERSION KIT

C350...1968-69 Impala

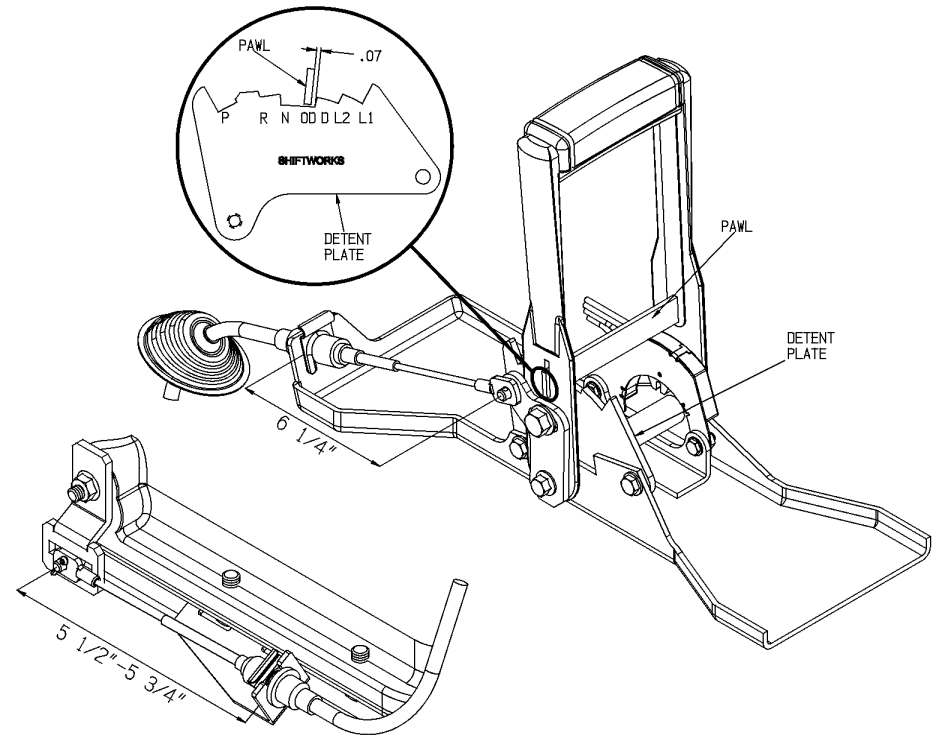
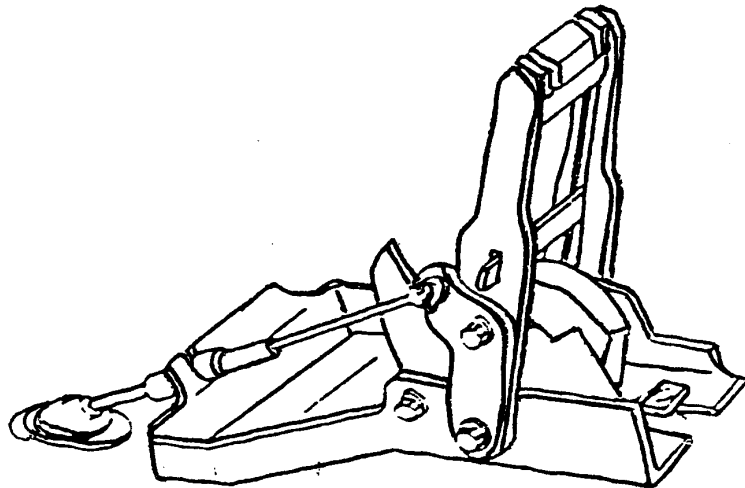
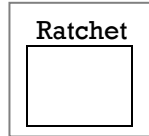

MANUAL LINKAGE ADJUSTMENT

1. Remove console and shifter.
2. Replace shifter detent.
3. Adjust so that the bar barely touches the detent in the Drive-Neutral gate. Tighten bolts.
4. Install the new pan bracket and shift control lever on the transmission. Use all the parts.
5. The cable is adjusted at the transmission by moving the pin in the shift control lever.
6. Put BOTH the Transmission and the Shifter in Drive. The distance from the pin to the face of the pan bracket should be about 5.5 to 5.75 inches. Adjust so that the cable eyelet can be freely removed when in gear and so that the shift handle is properly engaged.
7. Use SHIFTWORKS Cable #K100 or GM Cable #3956765.

NOTE: No other reproduction cables are recommended.

Kits convert the factory Automatic console shifter to 3-Speed Operation with all gears available

*NOT ALL 3-Speed Kits include new indicator lens

www.shiftworks.com
© 1995-2021 SHIFTWORKS®

www.shiftworks.com
© 1995-2021 SHIFTWORKS®