

DC Screw Motor Assembly Replacement

This repair will require removal of the unit from its mounting hardware and repairs made on a clean work surface. Refer to your Owners Manual and/or Installation Poster for proper assembly and carefully read and understand all warnings and cautions pertaining to your unit.

⚠ WARNING

BE SURE ELECTRICAL POWER HAS BEEN DISCONNECTED FROM THE INPUT POWER LINES PRIOR TO REMOVING THE MOTOR COVER.

⚠ WARNING

ANY AND ALL REPAIRS MADE TO THIS UNIT MUST BE PERFORMED WITH THE DOOR DISCONNECTED FROM THE OPENER AND IN THE CLOSED POSITION.

1. Before pulling emergency release cord, make certain people and objects are clear of door opening. Pull emergency release cord on carriage to disengage opener to close door if necessary. If unable to lower door using opener, use extreme caution manually closing door.
2. Unplug opener power cord from power receptacle.
3. Open lens cover by pressing middle tab inward to swing down and remove light bulbs. FIG. 1.
4. Mark wires to help facilitate replacement and remove wall control and Safe-T-Beam wires from terminal block located on side of opener FIG. 1. Use small common screwdriver to press in on orange tabs while gently pulling wires from block.
5. Remove network and battery backup harnesses from front of opener (if applicable).
6. Remove the cotter pin & clevis from door arm to separate door from opener. Door arm will swing downward. FIG. 2.
7. Remove motor head and rail assembly from mounting brackets/hardware and set on a clean work surface or floor.

Note: Be aware of the motion detector bulb on bottom of powerhead cover (if equipped). Do not set operator weight on this bulb.

8. Remove the 6-7/16" self tapping bolts from the rail/motor mounting flange and pull rail and coupler from motor head. FIG.3. Set rail assembly aside.

FIG. 1.

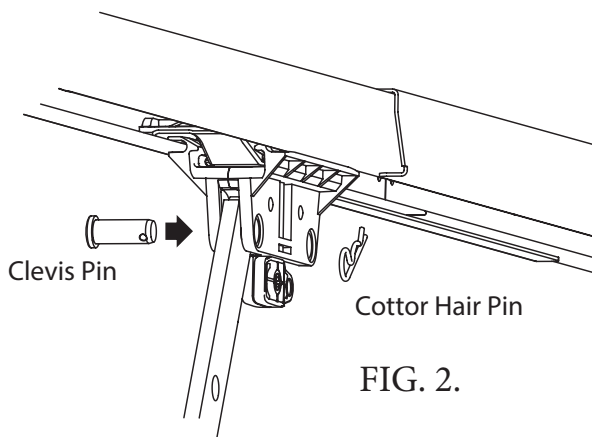
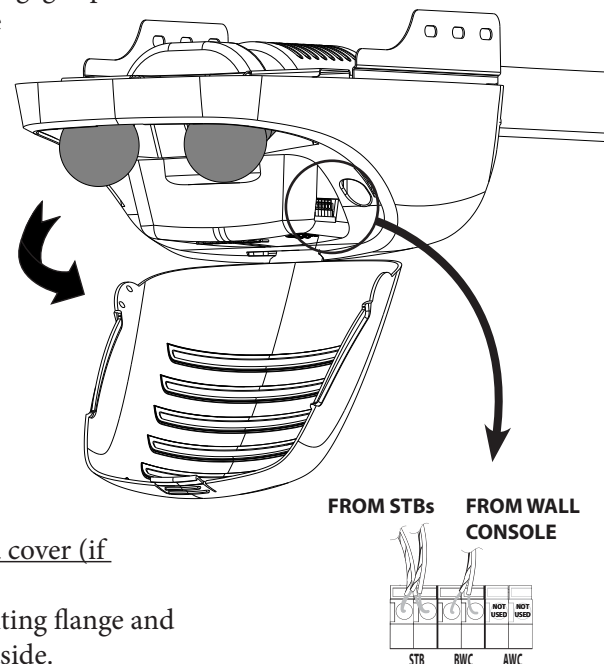
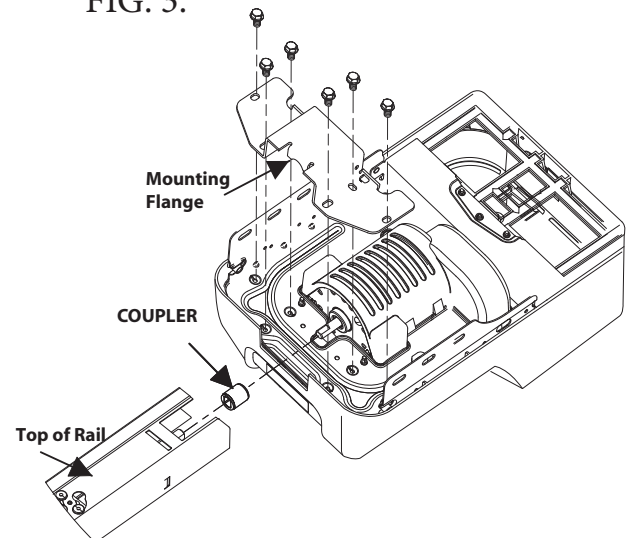

FIG. 3.



Scan code to view a video of this repair.

9. Remove two 5/16" screws securing powerhead cover to chassis and swing open to expose control board. Fig. 4.
- NOTE:** Do not remove control board from cover, shown for clarity only.
10. Unplug these harnesses from control board. FIG. 5.
 - Motor harness
 - Opto harness
 - AC in harness
 - Green ground wire to chassis from light harness (if equipped).
 11. Powerhead cover can now be removed from opener chassis.
 12. Remove three motor mounting bolts from motor frame FIG. 6. Remove motor assembly.
 13. Apply lube to shaft and install Opto Wheel onto replacement motor assembly. FIG. 7.
 14. Apply lube to Opto Wheel gear teeth. FIG. 7.
 15. Install motor assembly in reverse order. **OPTO HARNESS NOTE:**
Check the type of circuit board installed in your opener (see FIG. 8). Use appropriate harness included with this kit before installing motor.
 16. Hang powerhead cover to chassis to install harnesses. Including green ground wire to chassis (if equipped) **Note: Be certain to install all harnesses in the correct position being sure to install with locking tabs facing each other. (Detailed in FIG. 5 - Step 10)**
 17. Secure powerhead cover onto chassis using 2- 5/16" screws.
 18. Install rail to motor head assembly using coupler, mounting flange and 6-7/16" self tapping screws.
 19. Reinstall opener assembly in reverse order as removed. Reference your owners manual and installation poster.
 20. Install wall control and Safe-T-Beam® wires. Install battery backup and/or network harnesses if applicable.
 21. Install light bulbs and close lens cover.
 22. Plug opener into receptacle.
 23. Clear and reprogram limit controls per owners manual.

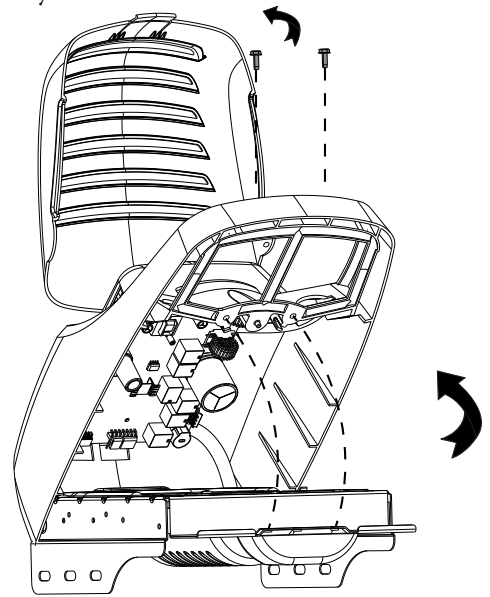

FIG. 4.

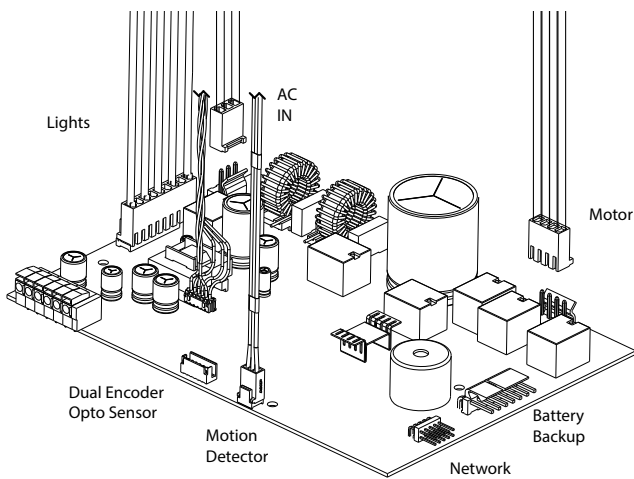

FIG. 5.

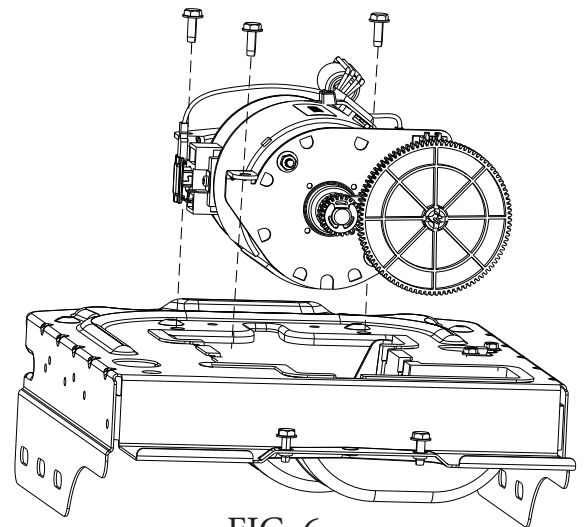

FIG. 6.

★ NOTE: Your Motor Cover may differ in appearance than illustrated. Replacement instructions are identical.

★ Parts removed for clarity

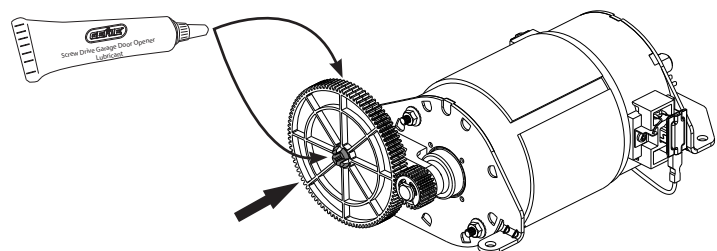
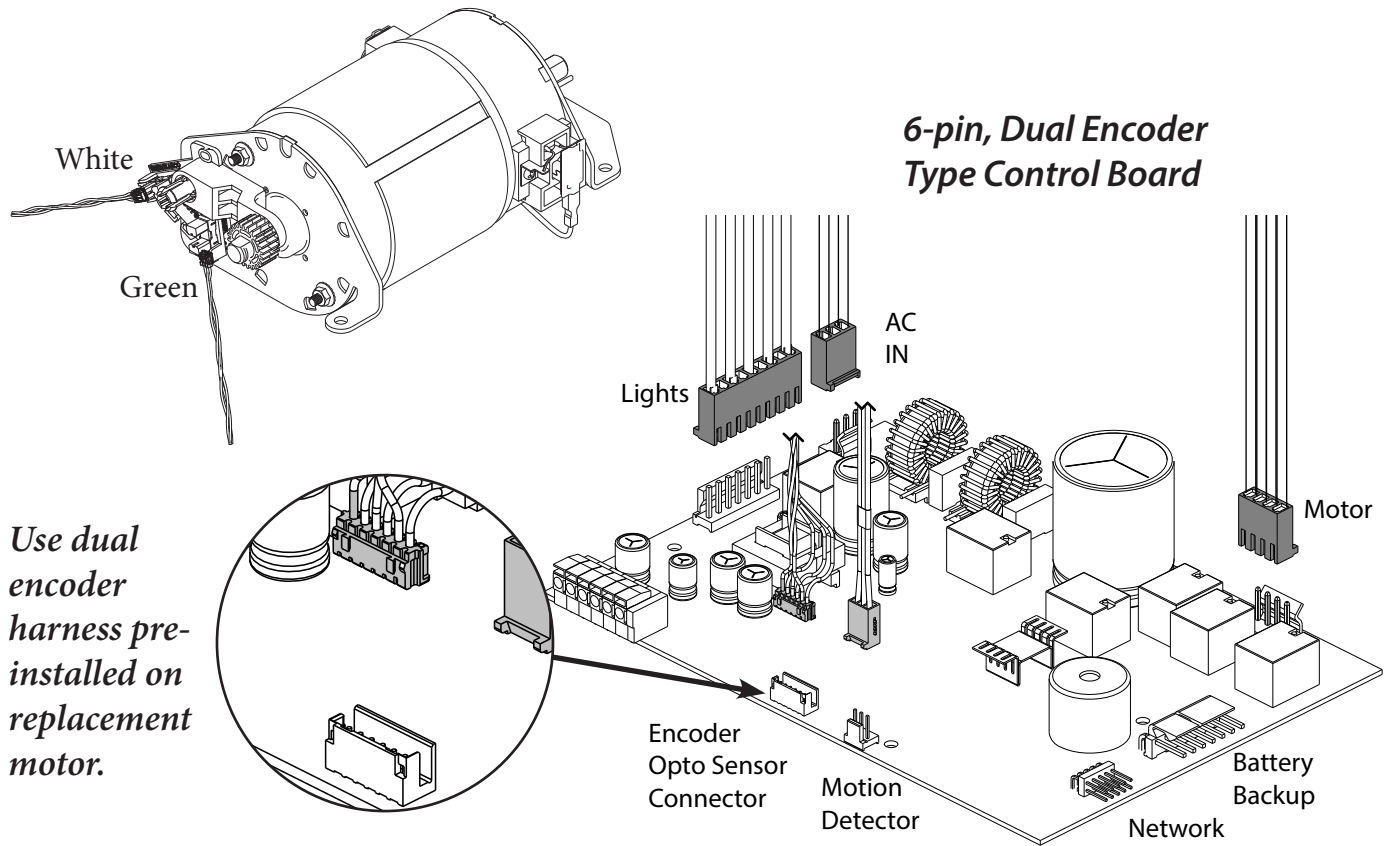
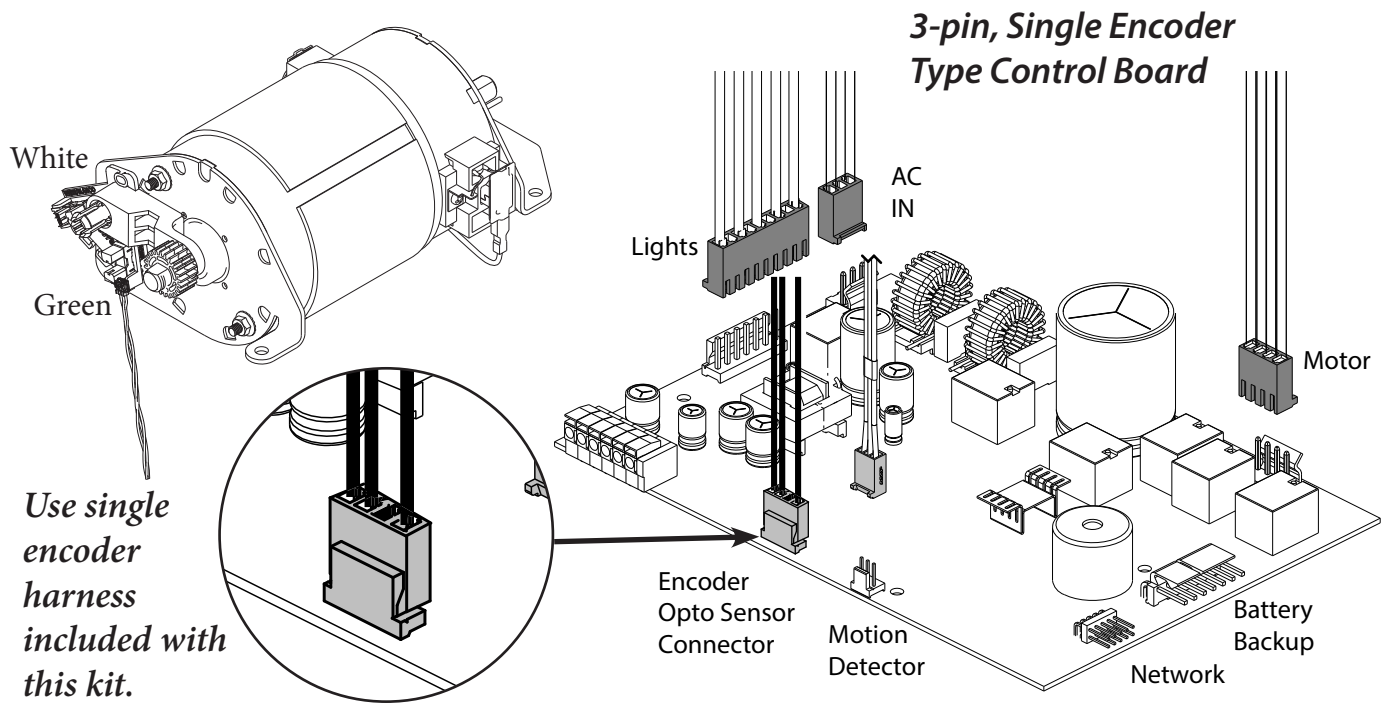

FIG. 7.



If your opener includes the dual encoder (6-pin) circuit board shown above, Use factory installed harness on replacement motor as shown.



If your opener includes the single encoder (3-pin) circuit board shown above, Remove dual encoder harness from replacement motor and install included single encoder harnesses as shown (Green side)

FIG.8.

★ Parts removed for clarity

DO NOT force harness plugs. Insert in proper direction

