

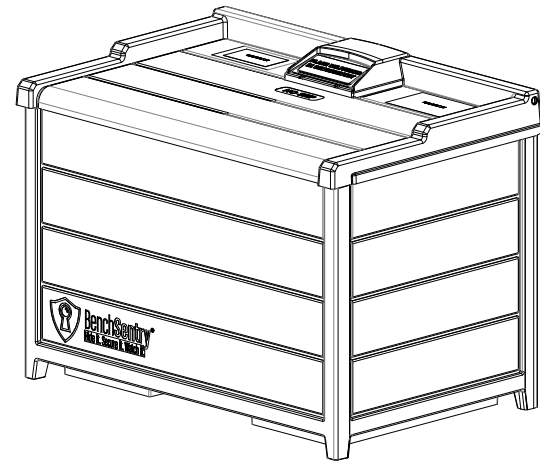

**BenchSentry™**  
by **GENIE**



# Package Delivery Box

## Assembly Instructions

### ▲ WARNING:

- To ensure safety, do not attempt to assemble this product without following the instructions carefully.
- Use caution when lifting and carrying to avoid injury.
- This product is NOT a toy chest. This product is NOT intended for use by children. To prevent possible risk of suffocation, DO NOT allow children to play inside this product.
- To prevent possible injury, when opening and closing the lid, keep fingers and hands clear of hinges and product opening.
- DO NOT store near excessive heat.
- This product may become susceptible to impact damage in freezing temperatures.
- To prevent possible injury, DO NOT stand on product.

Scan for easy 3D instructions

Tap. Zoom. Rotate with official interactive instructions on the BILT app.



**BILT.**



### Tools Required:

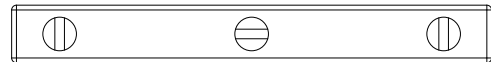

Level

### Parts Included:

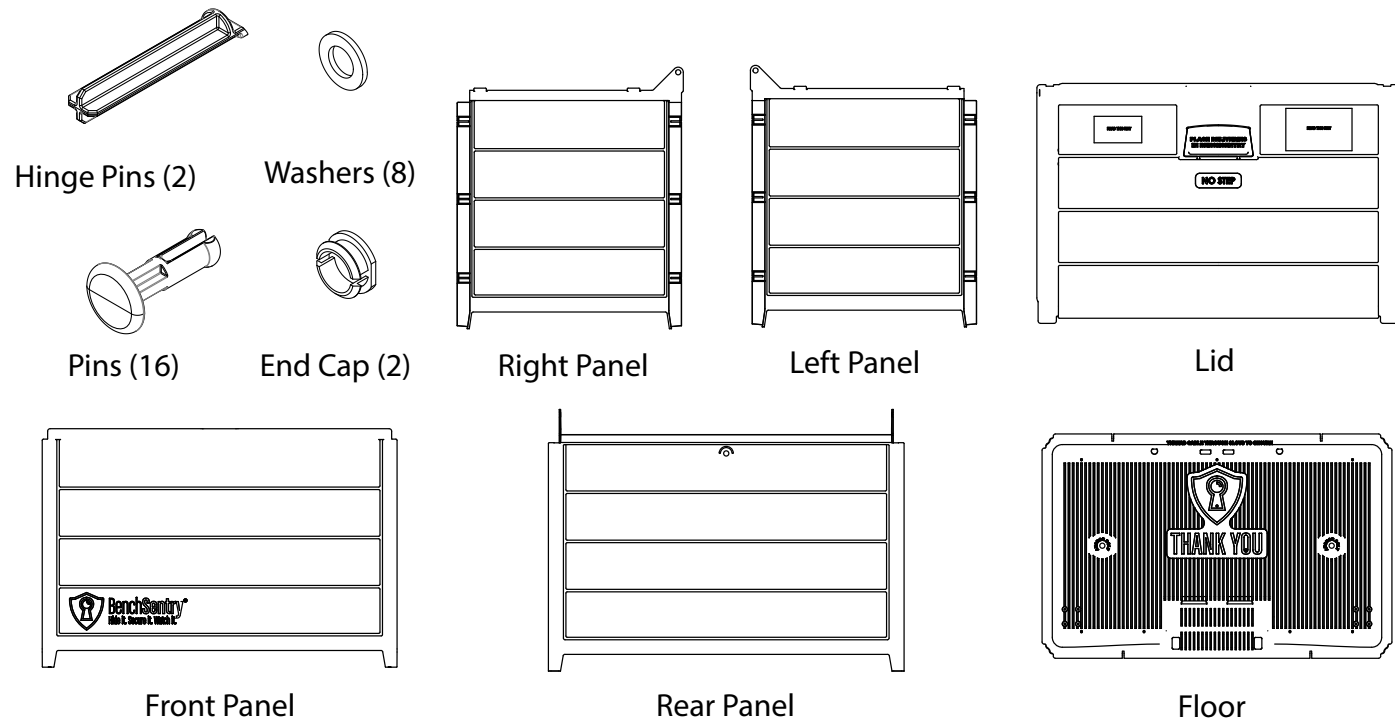

## 1 Attach Rear Panel to Left Side Panel

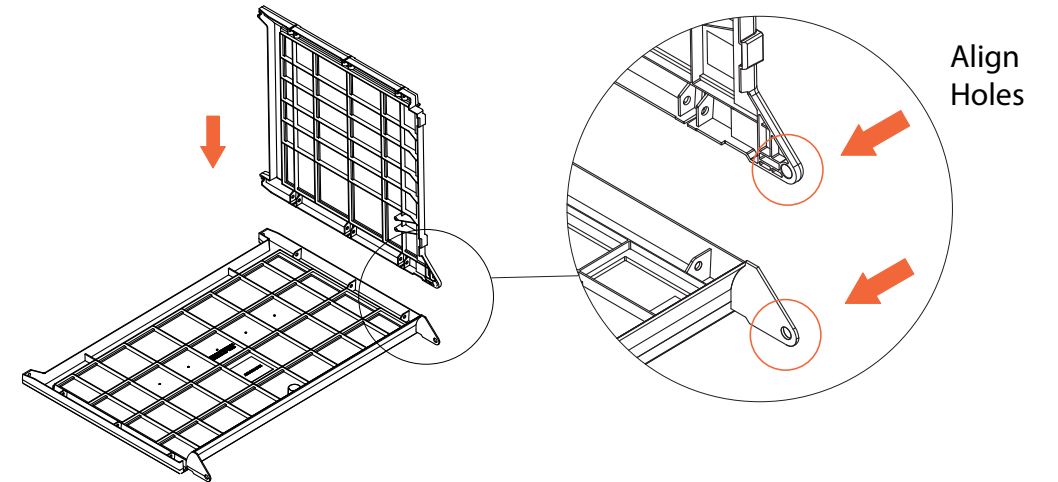

## 2 Install Pins (3)

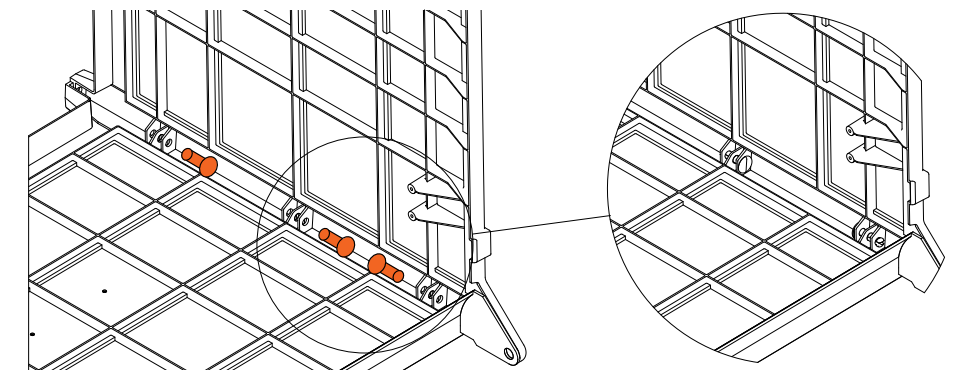

## 3 Attach Right Side Panel

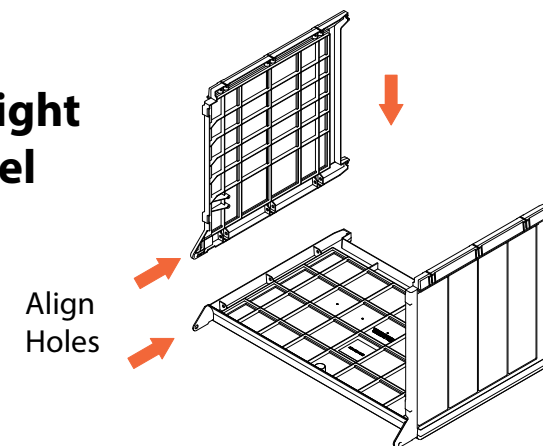

## 4 Install Pins (3)

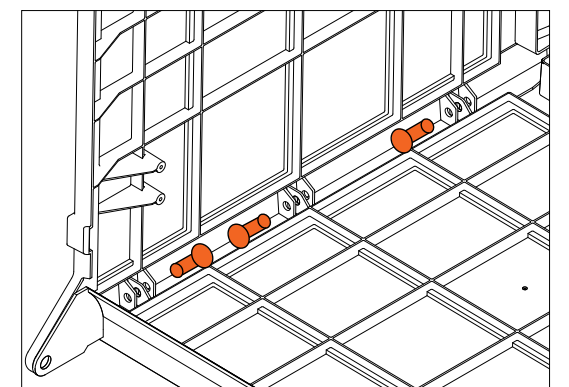

**5**  
Install Floor,  
Side into Place

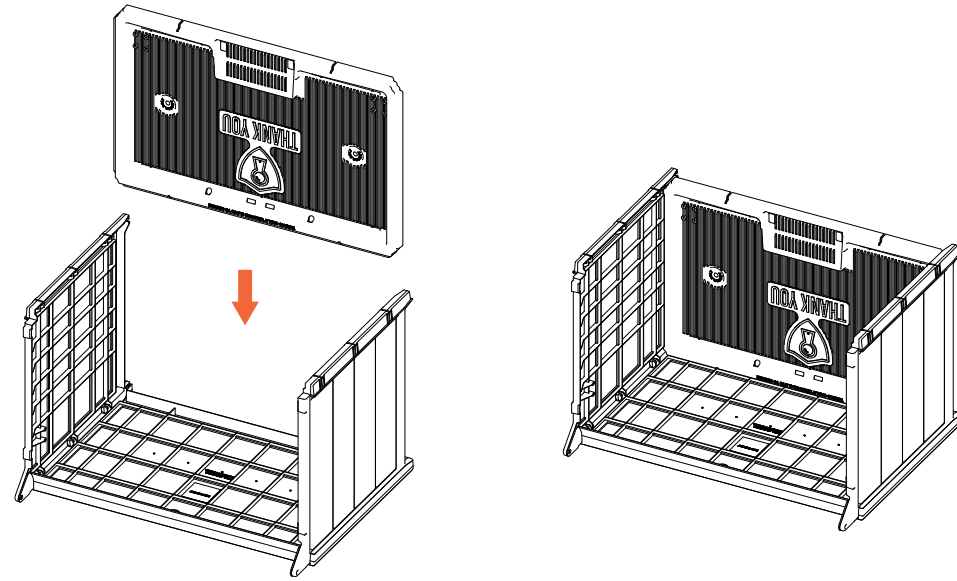

**8**  
Add Hinge  
Pin and Cap  
(left and  
right side)

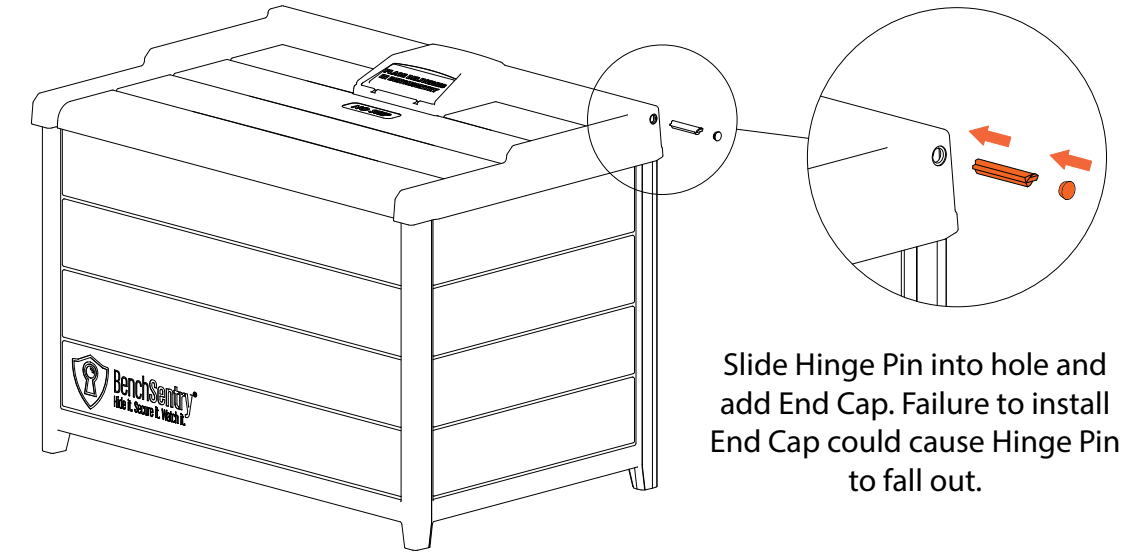

Slide Hinge Pin into hole and add End Cap. Failure to install End Cap could cause Hinge Pin to fall out.

**6**  
Attach Front Panel  
(add pins using  
the same method  
as previous steps)

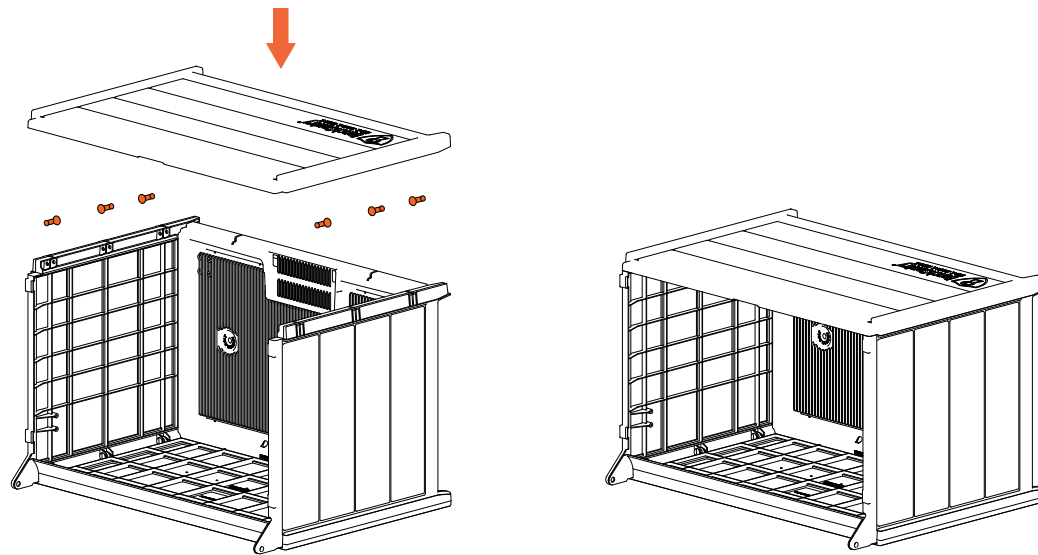

**9**  
Install Bottom  
Pins and Level  
BenchSentry®

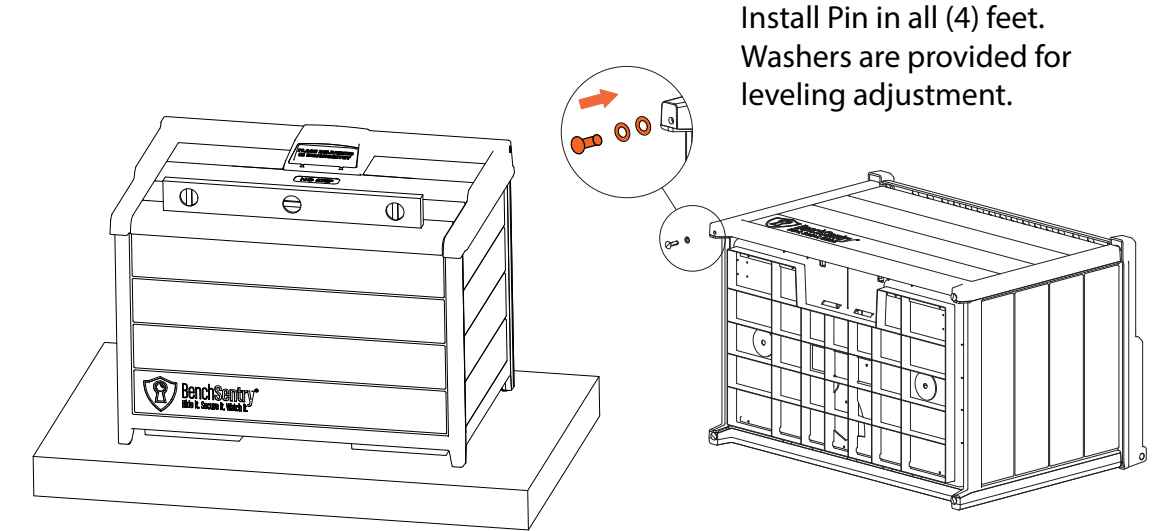

Install Pin in all (4) feet. Washers are provided for leveling adjustment.

**7**  
Lid Placement

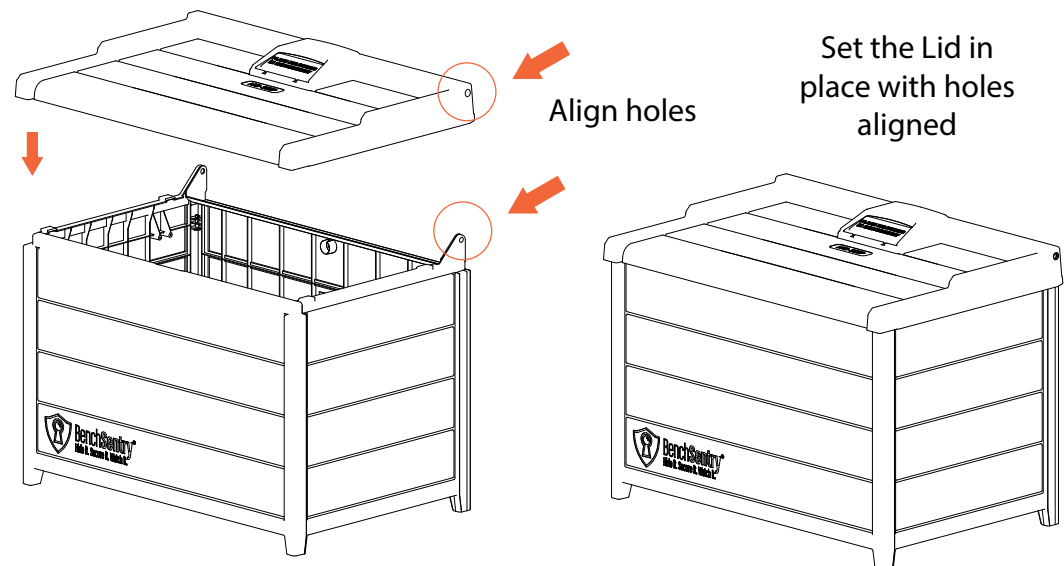

Place BenchSentry® on its feet

**10**  
Floor Anchor  
(Optional)

Holes provided to anchor BenchSentry® to concrete, wood, ect. (Hardware not included)

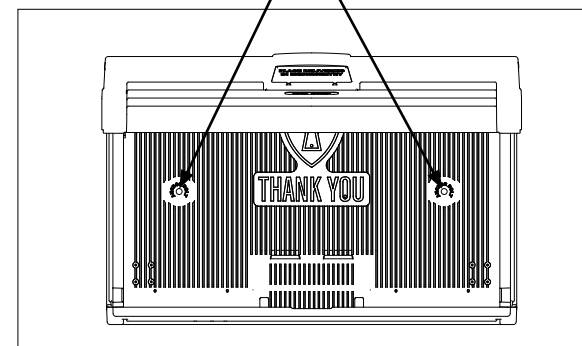

Thank you for purchasing a BenchSentry® by Genie® brand package protection system. You should enjoy many years of dependable, reliable operation. If you require any assistance or have questions, a knowledgeable Genie® Customer Service Representative is just a phone call away at:

**1-866-333-2911**

Or visit our website at:

[www.BenchSentry.com](http://www.BenchSentry.com)

[Genie\\_Support@GenieCompany.com](mailto:Genie_Support@GenieCompany.com)

For patent information, visit:

[www.geniecompany.com/patents](http://www.geniecompany.com/patents)

