

37857R

Tensioner Kit Replacement

This repair will require removal of the unit from its mounting hardware and repairs made on a bench or floor. Refer to your Owners Manual and/or Installation Poster for proper assembly and carefully read and understand all warnings and cautions pertaining to your unit.



WARNING

BE SURE ELECTRICAL POWER HAS BEEN DISCONNECTED FROM THE INPUT POWER LINES PRIOR TO REMOVING THE MOTOR COVER.



WARNING

ANY AND ALL REPAIRS MADE TO THIS UNIT MUST BE PERFORMED WITH THE DOOR DISCONNECTED FROM THE OPENER AND IN THE CLOSED POSITION.

1. Pull Emergency Release Cord on Carriage to disengage Opener to close door if necessary. (If unable to lower door using Opener, use extreme caution manually closing door. Before pulling Emergency Release Cord, make certain people and objects are clear of door opening.)
2. Unplug Opener Power Cord from power receptacle.
3. Open Lens Cover by pressing middle tab inward and remove Light Bulbs. FIG. 1. (See reverse side)
4. Remove Wall Control and Safe-T-Beam wires from Terminal Block located on side of Opener FIG. 1. Use small common screwdriver to press in on orange tabs while gently pulling wires from block. Mark wires to help facilitate replacement.
5. Remove Network and Battery Backup Harnesses from front of Opener (if applicable).
6. Remove the 2-9/16" Nuts & Bolts from Door Arms to separate door from Opener. FIG. 2.
7. Remove Motor Head and Rail Assembly from mounting brackets and set on a clean work surface or floor.
8. Remove the 4-7/16" self tapping bolts from the Rail/Motor mounting straps and pull Rail from Motor Head. FIG.3. Set Motor Head aside. Set Rail Assembly on floor upside down to aid in disassembly.
9. Loosen Tensioner Nut from door end of Rail to create slack in Belt/Chain. FIG. 4.
10. Remove 2-1/4" screws from Motor Pulley Assembly. FIG. 3.
11. Dislodge Motor Pulley Assembly from locking tabs (FIG. 3) and slide towards door end of rail to feed Tensioner Assembly, and Belt/Chain out through the end of the Rail approximately 8"-10". FIG. 5.
12. Remove Pulley Pin from Tensioner assembly and discard old Pulley. FIG. 5. Install replacement Pulley and Pin.
13. Slide Motor Pulley Assembly, and Tensioner Assembly back into original position making certain that locking tabs on Motor Pulley Assembly protrude through slots in Rail and secure with the 2-1/4" screws.
14. Tighten Tensioner Nut until slack is removed from Belt/Chain.
15. Install Rail to Motor Head Assembly using the two Mounting Straps and 4-7/16" self tapping screws.
16. Reinstall Opener Assembly in reverse order as removed. Reference your Owners Manual and Installation Poster.
17. Plug Opener in.
18. Clear and reprogram Limit Controls per Owners Manual.

FIG. 1.

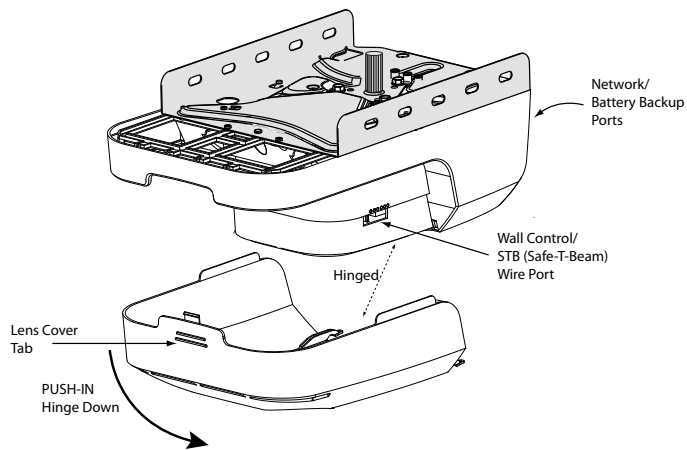

FIG. 2.

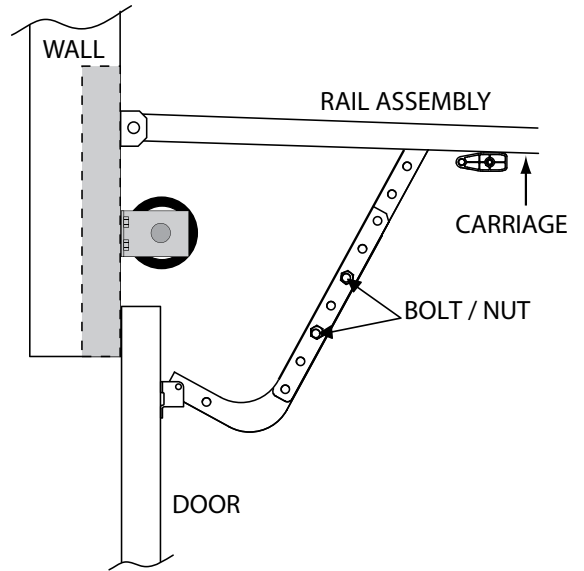

FIG. 3.

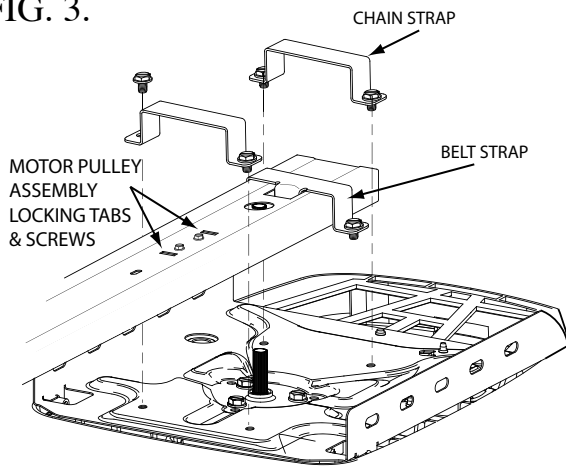

FIG.4.

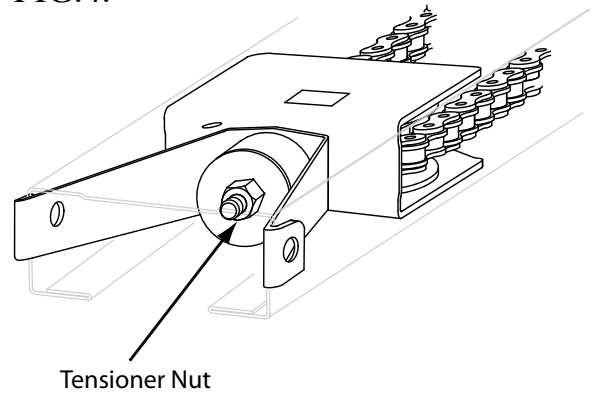

FIG.5.

