

36664R

Shuttle Replacement

This repair will require removal of the unit from its mounting hardware and repairs made on a bench or floor. Refer to your Owners Manual and/or Installation Poster for proper assembly and carefully read and understand all warnings and cautions pertaining to your unit.



WARNING

BE SURE ELECTRICAL POWER HAS BEEN DISCONNECTED FROM THE INPUT POWER LINES PRIOR TO REMOVING THE MOTOR COVER.



WARNING

ANY AND ALL REPAIRS MADE TO THIS UNIT MUST BE PERFORMED WITH THE DOOR DISCONNECTED FROM THE OPENER AND IN THE CLOSED POSITION.

1. Pull Emergency Release Cord on Carriage to disengage Opener to close door if necessary. (If unable to lower door using Opener, use extreme caution manually closing door. Before pulling Emergency Release Cord, make certain people and objects are clear of door opening.)
2. Unplug Opener Power Cord from power receptacle.
3. Open Lens Cover by pressing middle tab inward and remove Light Bulbs. FIG. 1. (See reverse side)
4. Remove Wall Control and Safe-T-Beam wires from Terminal Block located on side of Opener FIG. 2. Use small common screwdriver to press in on orange tabs while gently pulling wires from block. Mark wires to help facilitate replacement.
5. Remove Network and Battery Backup Harnesses from front of Opener (if applicable).
6. Remove the Cotter Pin & Clevis from Door Arm to separate door from Opener. FIG. 3.
7. Remove Motor Head and Rail Assembly from mounting brackets and set on a clean work surface or floor.
NOTE: Be aware of the Motion Detector Bulb on bottom of Powerhead Cover. Do not set operator weight on this bulb FIG. 4.
8. Pull emergency Release Cord to disconnect Shuttle from Rail (if not already released)
9. Push Shuttle out of Rail towards the door end of the Rail to remove old Shuttle.
10. Install new Shuttle in reverse order.
11. Reinstall Opener Assembly in reverse order as removed. Reference your Owners Manual and Installation Poster.
12. Install Wall Control and Safe-T-Beam wires. Install Battery Backup and/or Network Harnesses if applicable.
13. Install Light Bulbs and close Lens Cover.
14. Install Clevis & Cotter Pins from Door Arms to Shuttle.
15. Remove Release Cord and Handle from old Shuttle and Install on new Shuttle.
16. Move disconnect lever on Shuttle to the upwards position and operate Door until Shuttle connects with Carriage inside rail. These two will lock together.
17. Plug Opener in.
18. Clear and reprogram Limit Controls per Owners Manual.

FIG. 1.

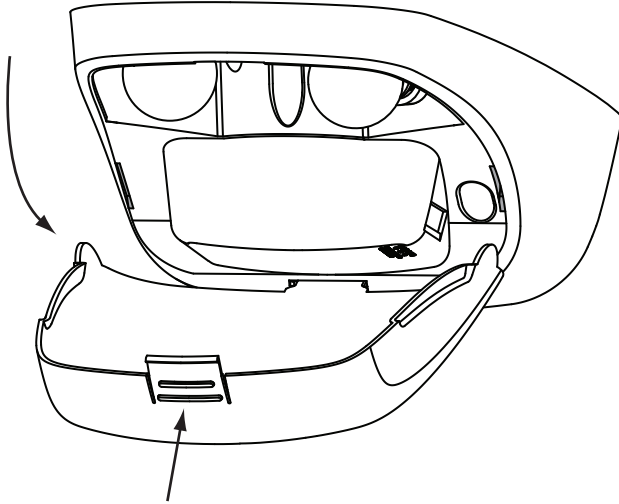

FIG. 2.

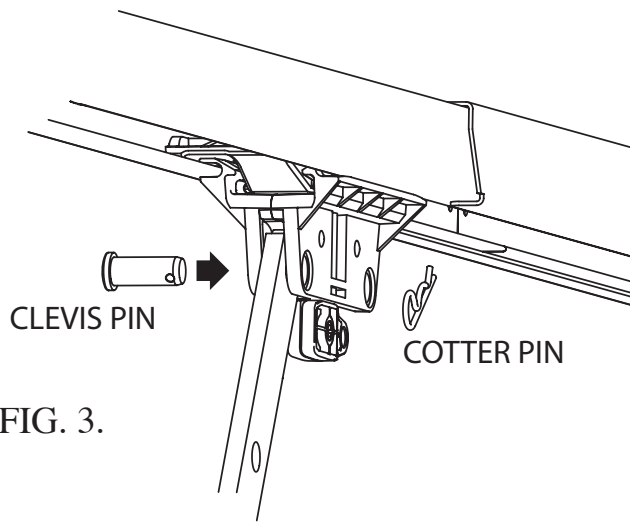
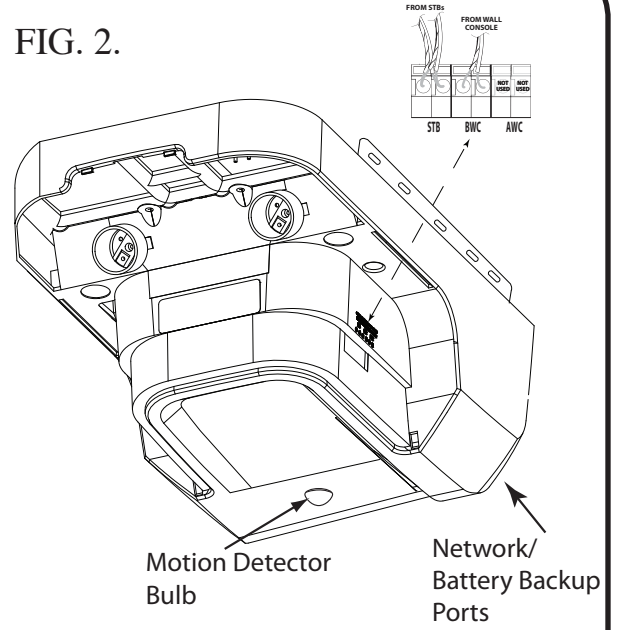

FIG. 3.

FIG. 4.

